

Evaluation Kit
Available

MAXIM

12V/15V or Adjustable, High-Efficiency, Low I_Q , Step-Up DC-DC Converters

General Description

The MAX761/MAX762 step-up switching regulators provide high efficiency over a wide range of load currents, delivering up to 150mA. A unique, current-limited pulse-frequency-modulated (PFM) control scheme gives the devices the benefits of pulse-width-modulated (PWM) converters (high efficiency with heavy loads), while using less than 110 μ A of supply current (vs. 2mA to 10mA for PWM converters). The result is high efficiency over a wide range of loads.

The MAX761/MAX762 input voltage range is 2V to 16.5V. Output voltages are preset to 12V (MAX761) and 15V (MAX762), or they can be set with two external resistors. With a 5V input, the MAX761 guarantees a 12V, 150mA output. Its high efficiency, low supply current, fast start-up time, SHDN controlling capability, and small size make the MAX761 ideal for powering flash memory.

The MAX761/MAX762 have an internal 1A power MOSFET, making them ideal for minimum-component, low- and medium-power applications. These devices use tiny external components, and their high switching frequencies (up to 300kHz) allow for small surface-mount magnetics.

For increased output drive capability or higher output voltages, use the MAX770–MAX773, which are similar in design to the MAX761/MAX762, but drive external power MOSFETs. For stepping up to 5V, see the MAX756/MAX757 and MAX856–MAX859 data sheets.

Applications

Flash Memory Programming
PCMCIA Cards
Battery-Powered Applications
High-Efficiency DC-DC Converters

Typical Operating Circuit

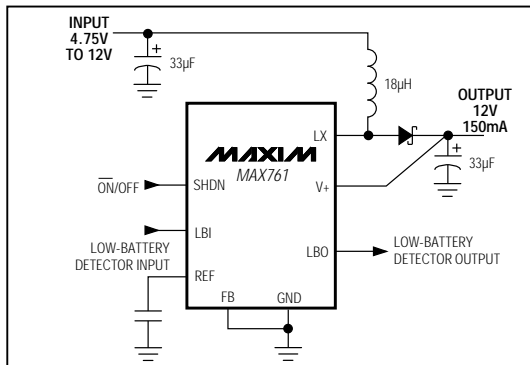

Features

- ◆ High Efficiency for a Wide Range of Load Currents
- ◆ 12V/150mA Flash Memory Programming Supply
- ◆ 110 μ A Max Supply Current
- ◆ 5 μ A Max Shutdown Supply Current
- ◆ 2V to 16.5V Input Voltage Range
- ◆ 12V (MAX761), 15V (MAX762) or Adjustable Output
- ◆ Current-Limited PFM Control Scheme
- ◆ 300kHz Switching Frequency
- ◆ Internal, 1A, N-Channel Power FET
- ◆ LBI/LBO Low-Battery Comparator

Ordering Information

PART	TEMP. RANGE	PIN-PACKAGE
MAX761CPA	0°C to +70°C	8 Plastic DIP
MAX761CSA	0°C to +70°C	8 SO
MAX761C/D	0°C to +70°C	Dice*
MAX761EPA	-40°C to +85°C	8 Plastic DIP
MAX761ESA	-40°C to +85°C	8 SO
MAX761MJA	-55°C to +125°C	8 CERDIP**
MAX762CPA	0°C to +70°C	8 Plastic DIP
MAX762CSA	0°C to +70°C	8 SO
MAX762C/D	0°C to +70°C	Dice*
MAX762EPA	-40°C to +85°C	8 Plastic DIP
MAX762ESA	-40°C to +85°C	8 SO
MAX762MJA	-55°C to +125°C	8 CERDIP**

* Contact factory for dice specifications.

** Contact factory for availability and processing to MIL-STD-883.

Pin Configuration

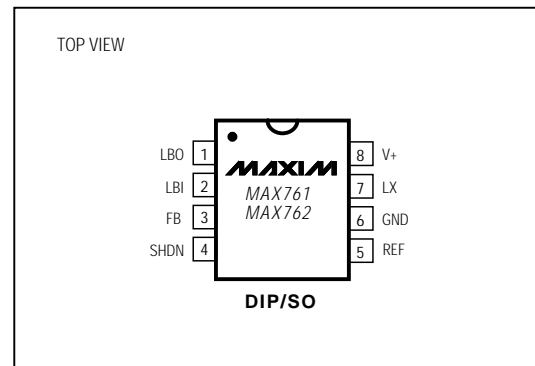

MAXIM

Maxim Integrated Products 1

Call toll free 1-800-998-8800 for free samples or literature.

MAX761/MAX762

12V/15V or Adjustable, High-Efficiency, Low I_Q , Step-Up DC-DC Converters

MAX761/MAX762

ABSOLUTE MAXIMUM RATINGS

Supply Voltage V_+ to GND	-0.3V to 17V
REF, LBO, LBI, SHDN, FB	-0.3V to ($V_+ + 0.3V$)
LX	-0.3V to 17V
LX Peak Current	1.5A
LBO Current	5mA
Continuous Power Dissipation ($T_A = +70^\circ\text{C}$)	
Plastic DIP (derate 9.09mW/ $^\circ\text{C}$ above $+70^\circ\text{C}$)	727mW
SO (derate 5.88mW/ $^\circ\text{C}$ above $+70^\circ\text{C}$)	471mW
CERDIP (derate 8.00mW/ $^\circ\text{C}$ above $+70^\circ\text{C}$)	640mW

Operating Temperature Ranges:

MAX76_C_A	0 $^\circ\text{C}$ to $+70^\circ\text{C}$
MAX76_E_A	-40 $^\circ\text{C}$ to $+85^\circ\text{C}$
MAX76_MJA	-55 $^\circ\text{C}$ to $+125^\circ\text{C}$
Junction Temperatures:	
MAX76_C_A/E_A	+150 $^\circ\text{C}$
MAX76_MJA	+175 $^\circ\text{C}$
Storage Temperature Range	-65 $^\circ\text{C}$ to $+160^\circ\text{C}$
Lead Temperature (soldering, 10sec)	+300 $^\circ\text{C}$

Stresses beyond those listed under "Absolute Maximum Ratings" may cause permanent damage to the device. These are stress ratings only, and functional operation of the device at these or any other conditions beyond those indicated in the operational sections of the specifications is not implied. Exposure to absolute maximum rating conditions for extended periods may affect device reliability.

ELECTRICAL CHARACTERISTICS

($V_+ = 5V$, $I_{LOAD} = 0mA$, $C_{REF} = 0.1\mu F$, $T_A = T_{MIN}$ to T_{MAX} , typical values are at $T_A = +25^\circ\text{C}$, unless otherwise noted.)

PARAMETER	SYMBOL	CONDITIONS	MIN	TYP	MAX	UNITS	
Supply Voltage	V_+	Figure 2, bootstrapped	2		16.5	V	
		Figure 3 or 5 with external resistors.	MAX76_C/E	3			16.5
			MAX76_M	3.1			16.5
Minimum Operating Voltage		Figure 2, bootstrapped		1.7		V	
Minimum Start-Up Voltage		Figure 2, bootstrapped		1.7	2.0	V	
Supply Current		$V_+ = 16.5V$, normal operation, SHDN = 0V, non-bootstrapped		88	110	μA	
		Figure 2, MAX761, $V_{IN} = 5V$, SHDN = 0V, normal operation		300			
Shutdown Current		$V_+ = 10.0V$, shutdown mode, SHDN = V_+		1	5	μA	
Output Voltage (Note 1)	V_{OUT}	Figure 2, MAX761, bootstrapped	$0mA \leq I_{LOAD} \leq 75mA$, $3V \leq V_+ \leq 12V$	11.52	12.0	12.48	V
			$0mA \leq I_{LOAD} \leq 150mA$, $4.75V \leq V_+ \leq 12V$	11.52	12.0	12.48	
		Figure 2, MAX762, bootstrapped	$0mA \leq I_{LOAD} \leq 50mA$, $3V \leq V_+ \leq 15V$	14.4	15.0	15.6	
			$0mA \leq I_{LOAD} \leq 100mA$, $4.75V \leq V_+ \leq 15V$	14.4	15.0	15.6	
Peak Current at LX	I_{PEAK}	See Figure 4b	0.75	1.0	1.25	A	
Maximum Switch-On Time	t_{ON}		6	8	10	μs	
Minimum Switch-Off Time	t_{OFF}		1.0	1.3	1.6	μs	
Load Regulation		Figure 2, $0mA \leq I_{LOAD} \leq 200mA$, bootstrapped		0.0042		%/mA	
Line Regulation		Figure 2, $4V \leq V_{IN} \leq 6V$, bootstrapped		0.08		%/V	
Efficiency		Figure 2, bootstrapped, $V_{OUT} = 12V$, $60mA \leq I_{LOAD} \leq 120mA$		86		%	
Reference Voltage	V_{REF}	MAX76_C	1.4700	1.50	1.5300	V	
		MAX76_E	1.4625	1.50	1.5375		
		MAX76_M	1.4550	1.50	1.5450		

12V/15V or Adjustable, High-Efficiency, Low I_Q , Step-Up DC-DC Converters

MAX761/MAX762

ELECTRICAL CHARACTERISTICS (continued)

($V_+ = 5V$, $I_{LOAD} = 0mA$, $C_{REF} = 0.1\mu F$, $T_A = T_{MIN}$ to T_{MAX} , typical values are at $T_A = +25^\circ C$, unless otherwise noted.)

PARAMETER	SYMBOL	CONDITIONS	MIN	TYP	MAX	UNITS	
Reference Load Regulation		$0\mu A \leq I_{LOAD} \leq 100\mu A$	MAX76_C/E		10	mV	
			MAX76_M		15		
Reference Line Regulation		$3.0V \leq V_+ \leq 16.5V$		30	100	$\mu V/V$	
LX Leakage Current		$V_+ = 16.5V$, $LX = 17V$	MAX76_C	-5	5	μA	
			MAX76_E	-10	10		
			MAX76_M	-30	30		
FB Leakage Current	I_{FB}	MAX76_C	-20	20	nA		
		MAX76_E	-40	40			
		MAX76_M	-60	60			
Voltage Trip Point	V_{FB}	MAX76_C	1.4700	1.50	1.5300	V	
		MAX76_E	1.4625	1.50	1.5375		
		MAX76_M	1.4550	1.50	1.5450		
LX On Resistance		$V_+ > 5.0V$		1.0	2.2	Ω	
SHDN Input High Voltage	V_{IH}	$2.0V \leq V_+ \leq 16.5V$	1.6			V	
SHDN Input Low Voltage	V_{IL}	$2.0V \leq V_+ \leq 16.5V$			0.4	V	
SHDN Leakage Current		$V_+ = 16.5V$, SHDN = 0V or V_+	-1		1	μA	
LBI Threshold Voltage		LBI falling	MAX76_C	1.4700	1.50	1.5300	V
			MAX76_E	1.4625	1.50	1.5375	
			MAX76_M	1.4550	1.50	1.5450	
LBI Hysteresis				20		mV	
LBI Leakage Current		$V_+ = 16.5V$, $V_{LBI} = 1.5V$	-20		20	nA	
LBO Leakage Current		$V_+ = 16.5V$, $V_{LBO} = 16.5V$	-1		1	μA	
LBO Voltage	V_{OL}	$V_+ = 5.0V$, $I_{SINK} = 1mA$			0.4	V	
LBI to LBO Delay		Overdrive = 5mV		2.5		μs	

Note 1: See *Typical Operating Characteristics* for output current capability versus input voltage. Guarantees based on correlation to switching on and off times, on-resistance, and peak-current ratings.

12V/15V or Adjustable, High-Efficiency, Low I_Q , Step-Up DC-DC Converters

Typical Operating Characteristics

(Circuit of Figure 2, $T_A = +25^\circ\text{C}$, unless otherwise noted.)

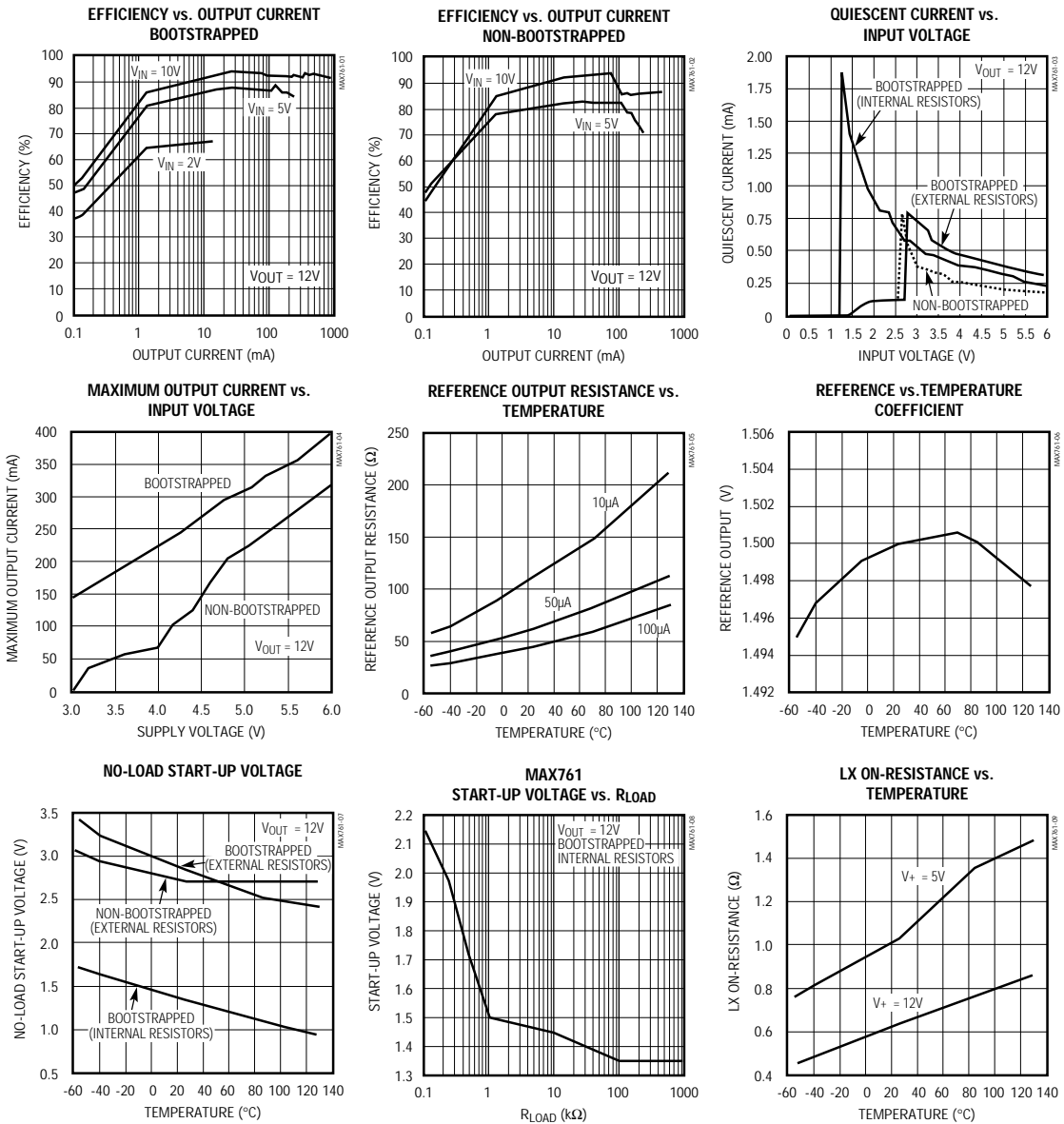

12V/15V or Adjustable, High-Efficiency, Low I_Q , Step-Up DC-DC Converters

Typical Operating Characteristics (continued)

(Circuit of Figure 2, $T_A = +25^\circ\text{C}$, unless otherwise noted.)

MAX761/MAX762

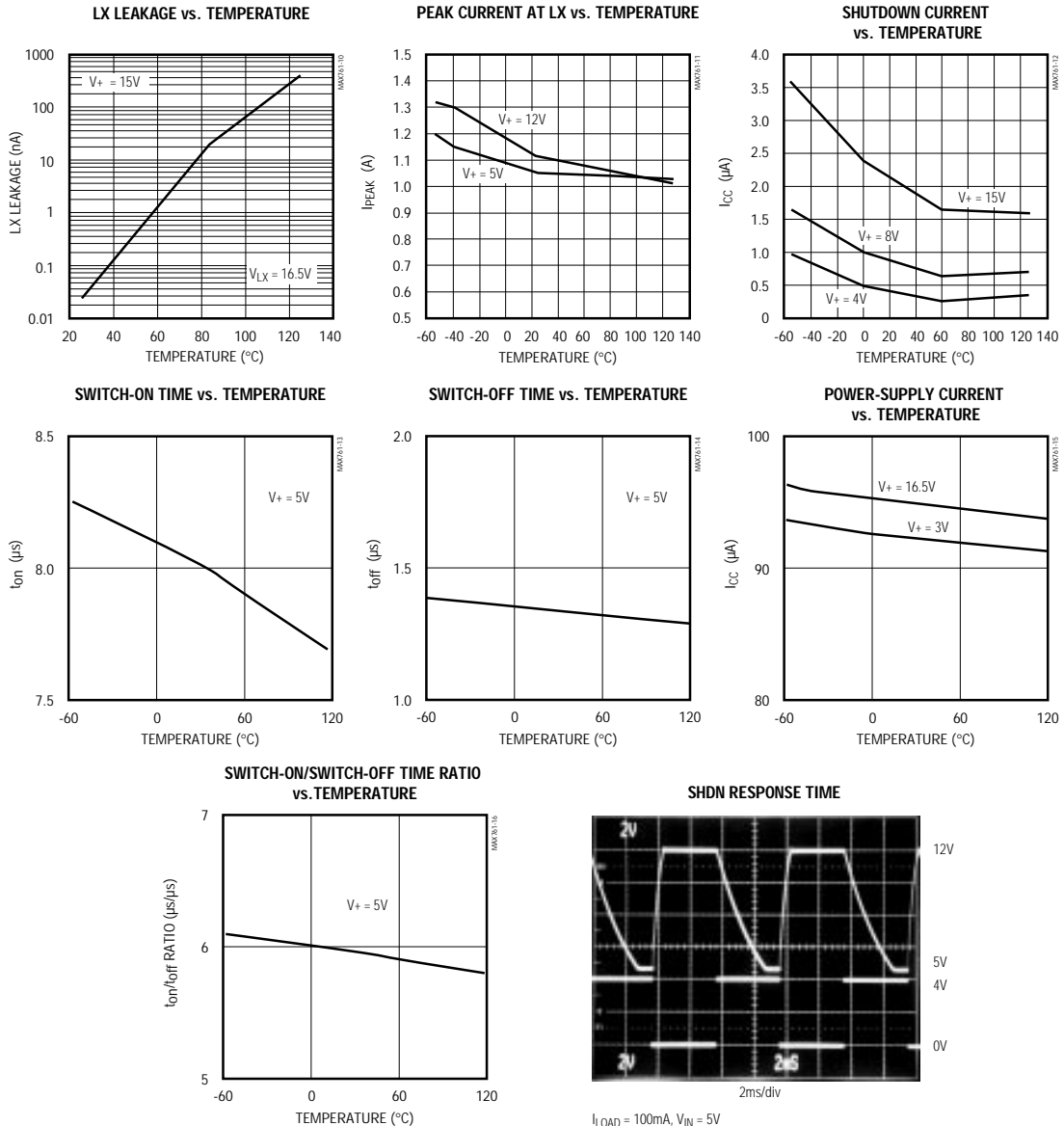

$I_{LOAD} = 100\text{mA}$, $V_{IN} = 5\text{V}$
 A: V_{out} , 2V/div
 B: SHDN (0V to 4V)

12V/15V or Adjustable, High-Efficiency, Low I_Q , Step-Up DC-DC Converters

Typical Operating Characteristics (continued)

(Circuit of Figure 2, $T_A = +25^\circ\text{C}$, unless otherwise noted.)

LOAD-TRANSIENT RESPONSE

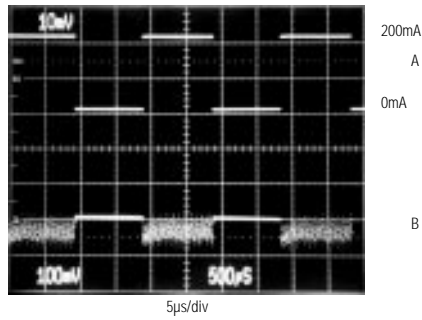

A: I_{LOAD} , (0mA to 200mA)
 B: V_{OUT} , AC COUPLED, 100mV/div
 $V_{IN} = 5V$, $V_{OUT} = 12V$

LINE-TRANSIENT RESPONSE

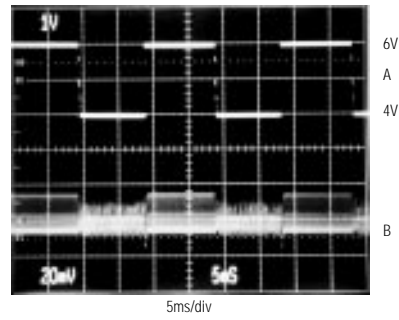

A: V_{IN} (4V to 6V)
 B: V_{OUT} , AC COUPLED, 20mV/div
 $I_{OUT} = 50mA$, $V_{OUT} = 12V$

Pin Description

PIN	NAME	FUNCTION
1	LBO	Low-battery output is an open-drain output that goes low when LBI is less than 1.5V. Connect to $V+$ through a pull-up resistor. Leave LBO floating if not used.
2	LBI	Input to the internal low-battery comparator. Tie to GND or $V+$ if not used.
3	FB	Feedback input. For fixed-output bootstrapped operation, connect FB to GND. For adjustable-output bootstrapped operation, connect a resistor divider between $V+$, FB and GND. For non-bootstrapped operation, there is no fixed-output option. Connect a resistor divider network between V_{OUT} , FB and GND. See <i>Bootstrapped/Non-Bootstrapped Modes</i> section.
4	SHDN	Active-high TTL/CMOS logic-level input. In shutdown mode ($SHDN = V+$), the internal switch is turned off and the output voltage equals $V+$ minus a diode drop (due to the DC path from the input to the output). Tie to GND for normal operation.
5	REF	1.5V reference output that can source 100µA for external loads. Bypass with 0.1µF or larger capacitor.
6	GND	Ground
7	LX	Drain of the internal N-channel FET. LX has an output resistance of 1Ω and a peak current limit of 1A.
8	$V+$	Power-supply input. In bootstrapped mode, $V+$ is also the output voltage sense input.

12V/15V or Adjustable, High-Efficiency, Low I_Q , Step-Up DC-DC Converters

MAX761/MAX762

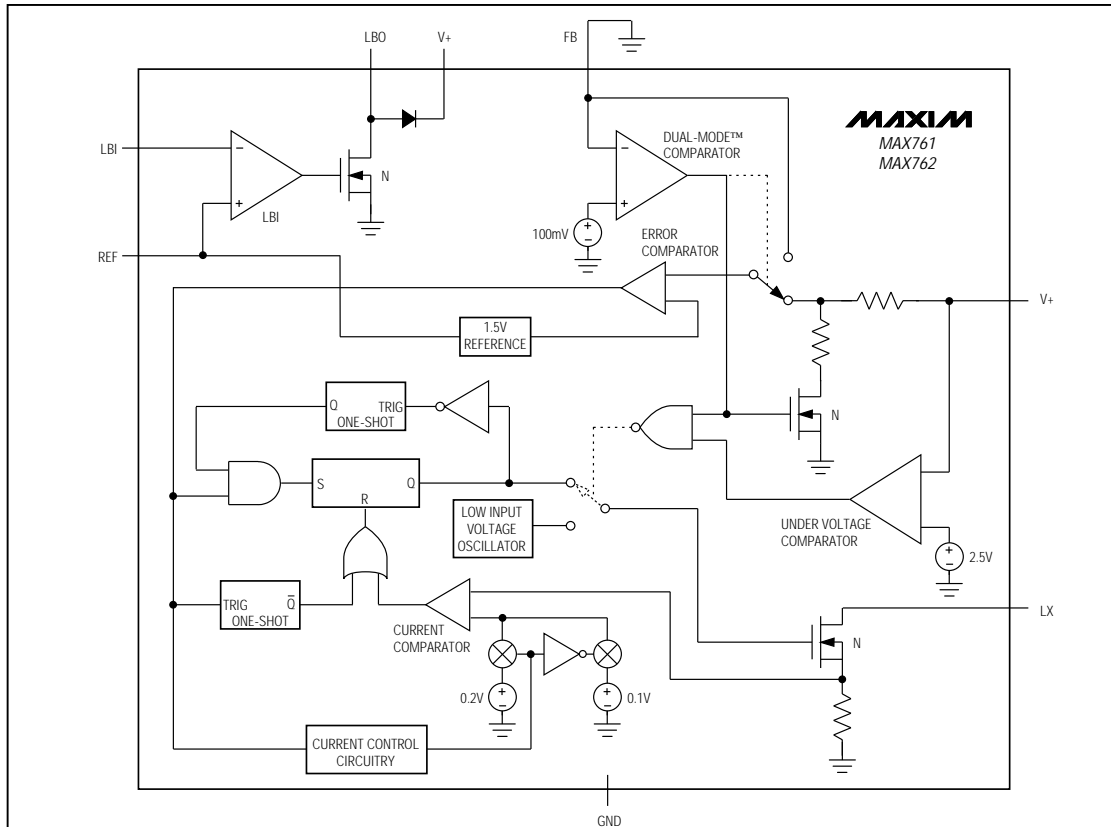

Figure 1. Simple Block Diagram

Detailed Description

Operating Principle

The MAX761/MAX762 BiCMOS step-up switch-mode power supplies provide fixed outputs of 12V and 15V, respectively. They have a unique control scheme that combines the advantages of pulse-frequency modulation (low supply current) and pulse-width modulation (high efficiency at high loads). The internal N-channel power MOSFET allows 1A peak currents, increasing the output current capability over previous pulse-frequency-modulation (PFM) devices. Figure 1 shows the MAX761/MAX762 block diagram.

The MAX761/MAX762 offer three main improvements over prior solutions: (1) the converters operate with tiny surface-mount inductors (less than 5mm diameter)

because of their 300kHz switching frequency, (2) the current-limited PFM control scheme allows 86% efficiencies over a wide range of load currents, and (3) the maximum supply current is only 110 μ A.

Bootstrapped/Non-Bootstrapped Modes

Figures 2 and 3 show the standard application circuits for bootstrapped and non-bootstrapped modes. In bootstrapped mode, the IC is powered from the output (V_{OUT}). In other words, the current needed to power the bootstrapped circuit is different from the V_+ current the chip consumes. The voltage applied to the gate of the internal N-channel FET is switched from V_{OUT} to ground, providing more switch-gate drive and increasing the efficiency of the DC-DC converter compared with non-bootstrapped operation.

12V/15V or Adjustable, High-Efficiency, Low I_Q , Step-Up DC-DC Converters

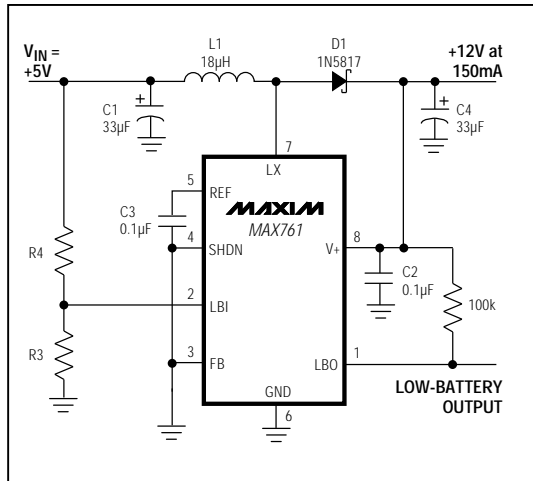

Figure 2. Bootstrapped Operating Circuit

In non-bootstrapped mode, the IC is powered from the supply voltage, V_{IN} , and operates with minimum supply current. Since the voltage applied to the gate of the internal FET is reduced, efficiency declines with low input voltages. **Note: In non-bootstrapped mode, there is no fixed-output operation; external resistors must be used to set the output voltage.** Use 1% external feedback resistors when operating in non-bootstrapped mode (Figure 3).

Use bootstrapped mode when V_{IN} is below approximately 4V. For V_{IN} between 4V and 6V, the trade-off is lower supply current in non-bootstrapped mode versus higher output current in bootstrapped mode (see *Typical Operating Characteristics*).

Pulse-Frequency Modulation (PFM) Control Scheme

The MAX761/MAX762 use a proprietary current-limited PFM control scheme. This control scheme combines the ultra-low supply current of pulse-skipping PFM converters with the high full-load efficiency characteristic of current-mode pulse-width-modulation (PWM) converters. It allows the devices to achieve high efficiency over a wide range of loads, while the current-sense function and high operating frequency allow the use of tiny external components.

As with traditional PFM converters, the internal power MOSFET is turned on when the voltage comparator senses the output is out of regulation (Figure 1). However, unlike traditional PFM converters, switching is accomplished through the combination of a peak cur-

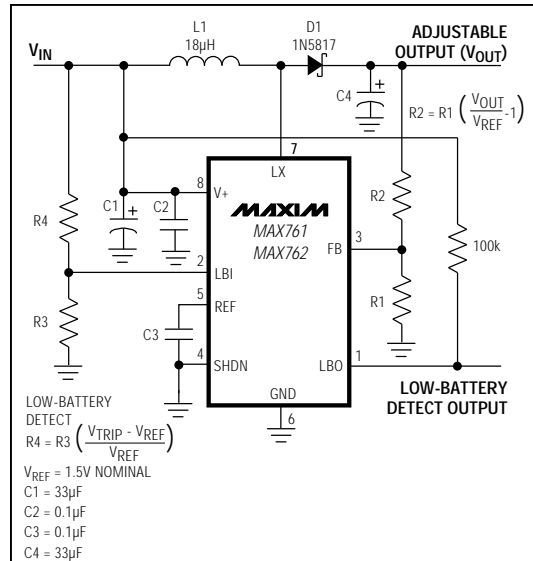

Figure 3. Non-Bootstrapped Operating Circuit

rent limit and a pair of one-shots that set the maximum on-time ($8\mu s$) and minimum off-time ($1.3\mu s$) for the switch. Once off, the minimum off-time one-shot holds the switch off for $1.3\mu s$. After this minimum time, the switch either (1) stays off if the output is in regulation, or (2) turns on again if the output is out of regulation.

The MAX761/MAX762 also limit the peak inductor current, allowing the devices to run in continuous-conduction mode (CCM) and maintain high efficiency with heavy loads (Figure 4a). This current-limiting feature is a key component of the control circuitry. Once turned on, the switch stays on until either (1) the maximum on-time one-shot turns it off ($8\mu s$ later), or (2) the current limit is reached.

To increase light-load efficiency, the current limit for the first two pulses is set to half the peak current limit. If those pulses bring the output voltage into regulation, the voltage comparator holds the MOSFET off, and the current limit remains at half the peak current limit. If the output voltage is still out of regulation after two pulses, the current limit for the next pulse is raised to the full current limit of 1A (Figure 4b).

Internal vs. External Resistors

When external feedback resistors are used, an internal undervoltage lockout system prevents start-up until $V+$ rises to about 2.7V. When external feedback resistors are

12V/15V or Adjustable, High-Efficiency, Low I_Q , Step-Up DC-DC Converters

MAX761/MAX762

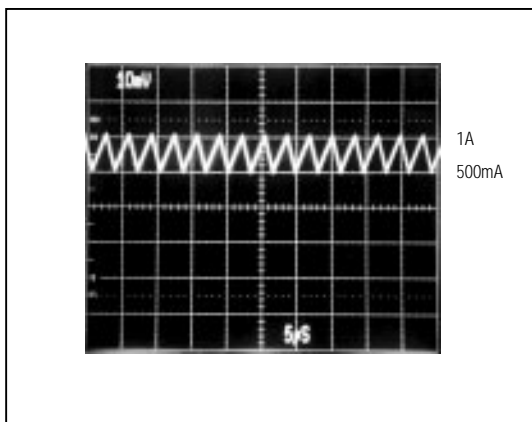

Figure 4a. CCM, Heavy Load Current Waveform (500mA/div)

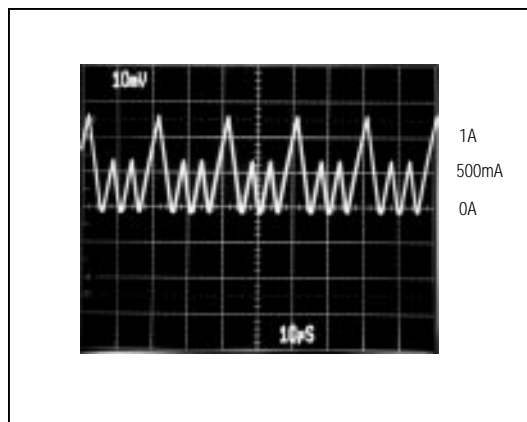

Figure 4b. Light/Medium Load Current Waveform (500mA/div)

used in a bootstrapped circuit (Figure 5), undervoltage lockout prevents start-up at low input voltages; but once started, operation can continue down to a lower voltage that depends on the load.

There is no undervoltage lockout when the internal feedback resistors are used (Figure 2), and special circuitry guarantees start-up at 2.0V. The start-up circuitry fixes the duty cycle at 50% until V_+ is driven to 2.5V, above which the normal control system takes over.

Shutdown Mode

The MAX761/MAX762 enter shutdown mode when SHDN is high. In this mode, the internal biasing circuitry is turned off (including the reference) and V_{OUT} equals V_+ minus a diode drop (due to the DC path from the input to the output). In shutdown mode, the supply current drops to less than 5 μ A. SHDN is a TTL/CMOS logic level input. Connect SHDN to GND for normal operation. LBO is high impedance during shutdown.

Modes of Operation

When delivering high output currents, the MAX761/MAX762 operate in CCM. In this mode, current always flows in the inductor, and the control circuit adjusts the switch's duty cycle on a cycle-by-cycle basis to maintain regulation without exceeding the switch-current capability. This provides excellent load-transient response and high efficiency.

In discontinuous-conduction mode (DCM), current through the inductor starts at zero, rises to a peak value, then ramps down to zero on each cycle. Although efficiency is still excellent, the switch waveforms contain

ringing (the inductor's self-resonant frequency). This ringing is normal and poses no operational problems.

Low-Battery Detector

The MAX761/MAX762 provide a low-battery comparator that compares the voltage on LBI to the 1.5V reference voltage. When the LBI voltage is below V_{REF} , LBO (an open-drain output) goes low. The low-battery comparator's 20mV of hysteresis adds noise immunity, preventing repeated triggering of LBO. Use a resistor-divider network between V_+ , LBI, and GND to set the desired trip voltage V_{TRIP} (Figure 3). When SHDN is high, LBI is ignored and LBO is high impedance. The value of resistor R3 should be no larger than 500k Ω to ensure the LBI leakage current does not cause inaccuracies in V_{TRIP} .

Design Procedure

Setting the Output Voltage

The MAX761/MAX762's output voltage can be adjusted from 5V to 16.5V using external resistors R1 and R2 configured as shown in Figures 3 and 5. For adjustable-output operation, select feedback resistor R1 in the 10k Ω to 250k Ω range. Higher R1 values within this range give lowest supply current and best light-load efficiency. R2 is given by:

$$R2 = (R1) \left(\frac{V_{OUT}}{V_{REF}} - 1 \right)$$

where $V_{REF} = 1.5V$.

Note: Tie FB to GND for fixed-output operation (bootstrapped mode only).

12V/15V or Adjustable, High-Efficiency, Low I_Q, Step-Up DC-DC Converters

MAX761/MAX762

Reference Capacitor

Bypass REF with a 0.1μF capacitor. REF can source up to 100μA.

Connect a pull-up resistor (e.g., 100kΩ) between LBO and V_{OUT}. Tie LBI to GND or V+ and leave LBO floating if the low-battery detector is not used.

Setting the Low-Battery Detector Voltage
To set the low-battery detector's falling trip voltage (V_{TRIP}), select R3 between 10kΩ and 500kΩ (Figures 2 and 3), and calculate R4 as follows:

$$R4 = R3 \left[\frac{V_{TRIP} - V_{REF}}{V_{REF}} \right]$$

where V_{REF} = 1.5V.

The rising trip voltage is higher because of the comparator's hysteresis of approximately 20mV, and can be calculated by:

$$V_{TRIP}(\text{rising}) = (V_{REF} + 20\text{mV})(1 + R4/R3).$$

Connect a high-value resistor (larger than R3 + R4) between LBI and LBO if additional hysteresis is required.

Applications Information

Layout Considerations

Proper PC board layout is essential because of high current levels and fast switching waveforms that radiate noise. Minimize ground noise by connecting GND, the input bypass-capacitor ground lead, and the output filter-capacitor ground lead to a single point (star ground configuration). Also minimize lead lengths to reduce stray capacitance, trace resistance, and radiated noise. The traces connected to FB and LX, in particular, must be short. Place bypass capacitor C2 as close as possible to V+ and GND.

Table 1. Component Suppliers

PRODUCTION METHOD	INDUCTORS	CAPACITORS	DIODES
Surface Mount	Sumida CD54-180 (22μH) Coiltronics CTX 100-series	Matsuo 267 series	Nihon EC10 series
Miniature Through-Hole	Sumida RCH855-180M	Sanyo OS-CON series Low-ESR organic semiconductor	Motorola 1N5817, MUR105
Low-Cost Through-Hole	Renco RL 1284-18	Nichicon PL series Low-ESR electrolytics United Chemi-Con LXF series	

Coiltronics	(USA)	(407) 241-7876	FAX (407) 241-9339
Matsuo	(USA)	(714) 969-2491	FAX (714) 960-6492
Matsuo	(Japan)	81-6-337-6450	FAX 81-6-337-6456
Nichicon	(USA)	(708) 843-7500	FAX (708) 843-2798
Nihon	(USA)	(805) 867-2555	FAX (805) 867-2556
Renco	(USA)	(516) 586-5566	FAX (516) 586-5562
Sanyo	(USA)	(619) 661-6835	FAX (619) 661-1055
Sanyo	(Japan)	(0720) 70-1005	FAX (0720) 70-1174
Sumida	(USA)	(708) 956-0666	
Sumida	(Japan)	81-3-607-5111	FAX 81-3-607-5144
United Chem-Con	(USA)	(714) 255-9500	FAX (714) 255-9400

12V/15V or Adjustable, High-Efficiency, Low I_Q , Step-Up DC-DC Converters

MAX761/MAX762

Chip Topography

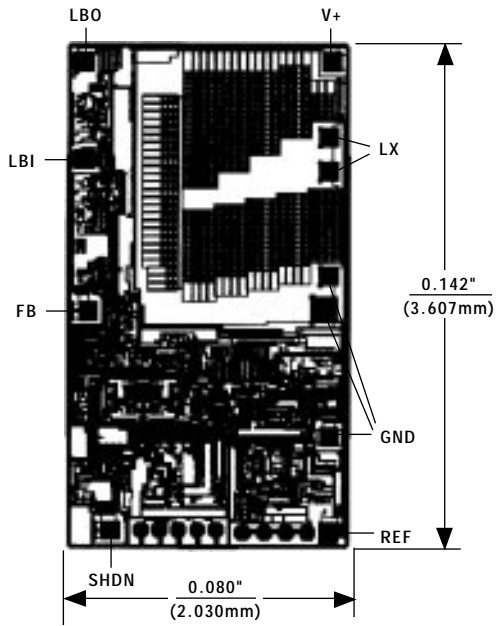

TRANSISTOR COUNT: 492;
SUBSTRATE CONNECTED TO V+.

Maxim cannot assume responsibility for use of any circuitry other than circuitry entirely embodied in a Maxim product. No circuit patent licenses are implied. Maxim reserves the right to change the circuitry and specifications without notice at any time.

12 Maxim Integrated Products, 120 San Gabriel Drive, Sunnyvale, CA 94086 (408) 737-7600

© 1993 Maxim Integrated Products

Printed USA

MAXIM is a registered trademark of Maxim Integrated Products.