

HEF4516B

Binary up/down counter

Rev. 06 — 11 December 2009

Product data sheet

1. General description

The HEF4516B is an edge-triggered synchronous 4-bit binary up/down counter with a clock input (CP), an up/down count control input (UP/DN), an active LOW count enable input (\overline{CE}), an asynchronous active HIGH parallel load input (PL), four parallel inputs (D0 to D3), four parallel outputs (Q0 to Q3), an active LOW terminal count output (\overline{TC}), and an overriding asynchronous master reset input (MR).

Information on D0 to D3 is loaded into the counter while PL is HIGH, independent of all other input conditions except for MR which must be LOW. When PL and \overline{CE} are LOW, the counter changes on the LOW-to-HIGH transition of CP. Input UP/DN determines the direction of the count, counting up when HIGH and counting down when LOW. When counting up, \overline{TC} is LOW when Q0 and Q3 are HIGH and \overline{CE} is LOW. When counting down, \overline{TC} is LOW when Q0 to Q3 and \overline{CE} are LOW. A HIGH on MR resets the counter (Q0 to Q3 = LOW) independent of all other input conditions.

It operates over a recommended V_{DD} power supply range of 3 V to 15 V referenced to V_{SS} (usually ground). Unused inputs must be connected to V_{DD} , V_{SS} , or another input. It is also suitable for use over the full industrial ($-40\text{ }^{\circ}\text{C}$ to $+85\text{ }^{\circ}\text{C}$) temperature range.

2. Features

- Fully static operation
- 5 V, 10 V, and 15 V parametric ratings
- Standardized symmetrical output characteristics
- Operates across the full industrial temperature range $-40\text{ }^{\circ}\text{C}$ to $+85\text{ }^{\circ}\text{C}$
- Complies with JEDEC standard JESD 13-B

3. Applications

- Industrial

4. Ordering information

Table 1. Ordering information

All types operate from $-40\text{ }^{\circ}\text{C}$ to $+85\text{ }^{\circ}\text{C}$.

Type number	Package		Version
	Name	Description	
HEF4516BP	DIP16	plastic dual in-line package; 16-leads (300 mil)	SOT38-4
HEF4516BT	SO16	plastic small outline package; 16 leads; body width 3.9 mm	SOT109-1



5. Functional diagram

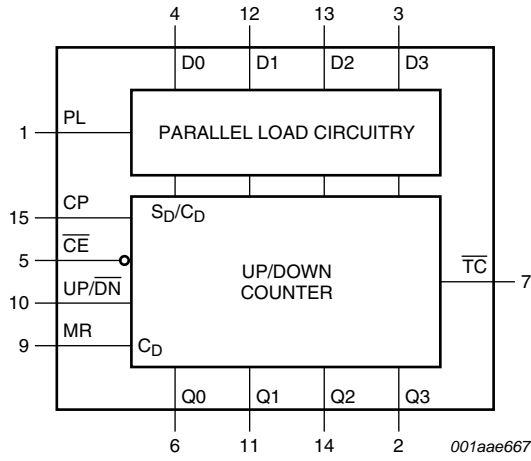

Fig 1. Functional diagram

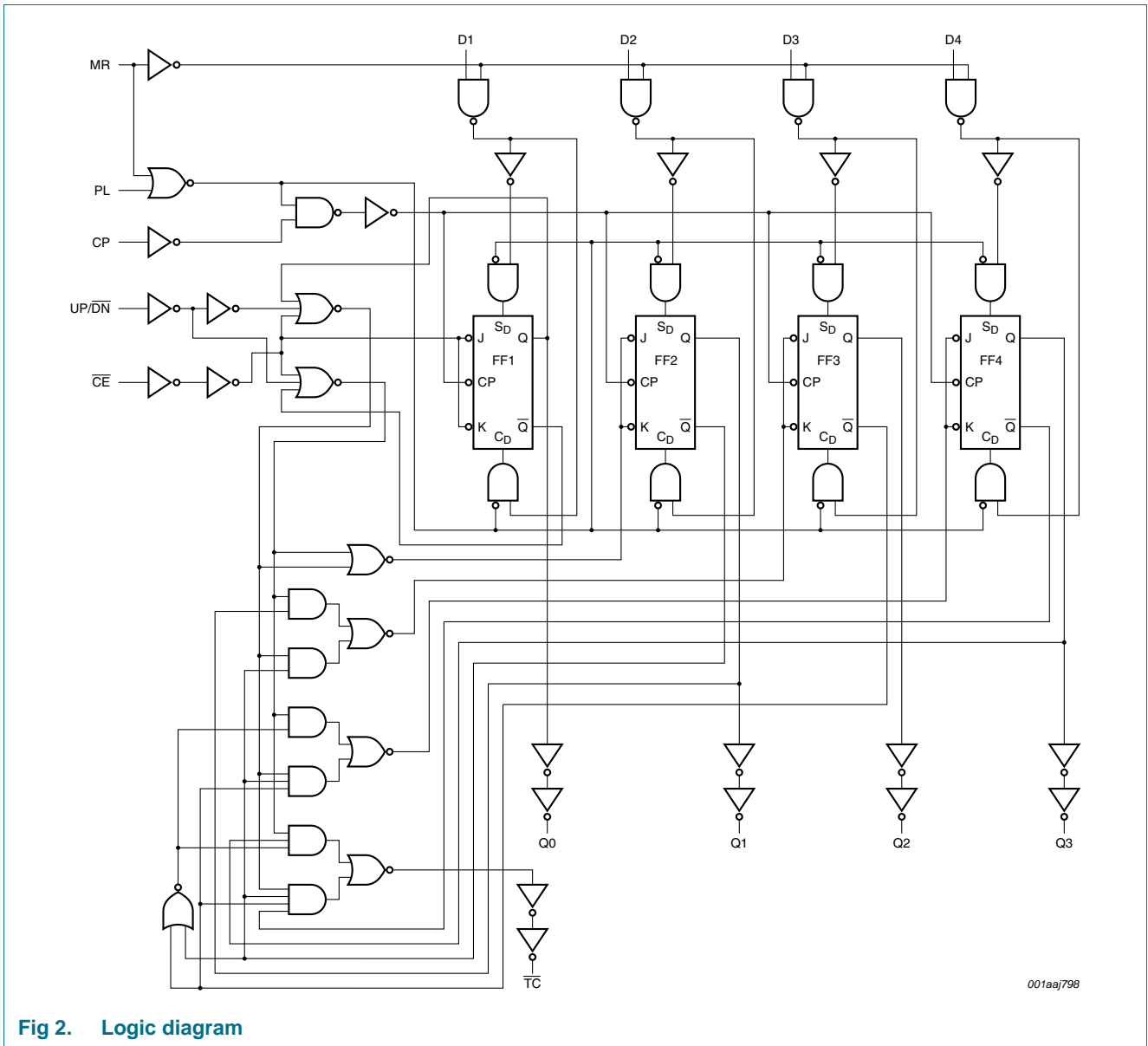
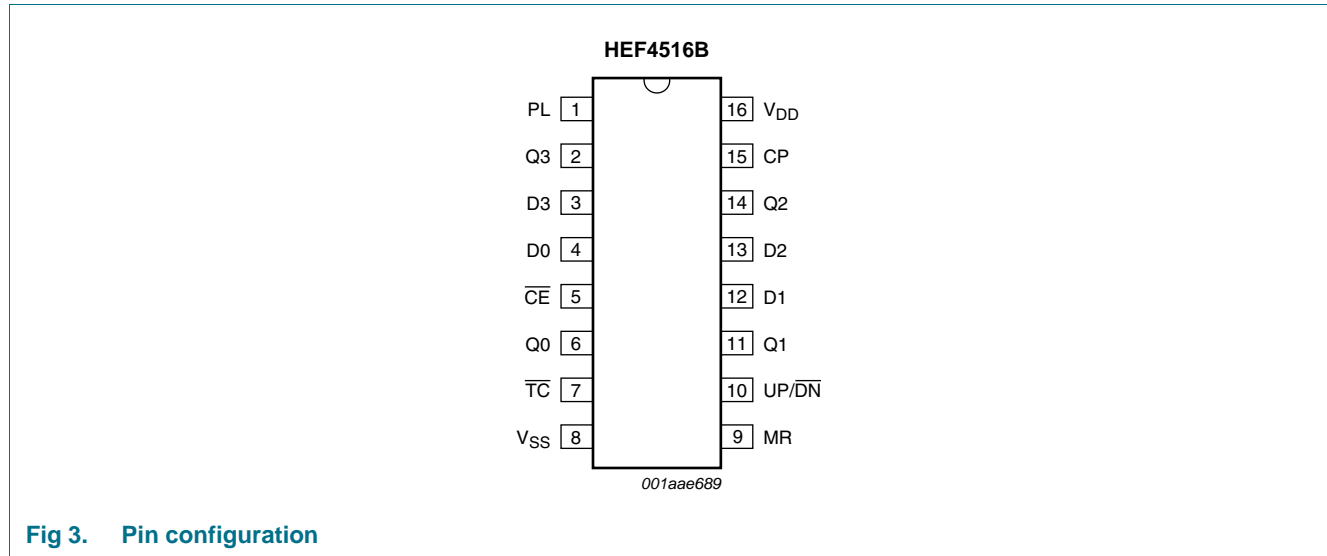

Fig 2. Logic diagram

6. Pinning information

6.1 Pinning



6.2 Pin description

Table 2. Pin description

Symbol	Pin	Description
PL	1	parallel load input (active HIGH)
D0 to D3	4, 12, 13, 3	parallel input
\overline{CE}	5	count enable input (active LOW)
Q0 to Q3	6, 11, 14, 2	parallel output
V _{SS}	8	ground supply voltage
\overline{TC}	7	terminal count output (active LOW)
MR	9	master reset input
UP/ \overline{DN}	10	up/down count control input
CP	15	clock pulse input (LOW to HIGH, edge triggered)
V _{DD}	16	supply voltage

7. Functional description

Table 3. Function table^[1]

MR	PL	UP/DN	CE	CP	MODE
L	H	X	X	X	parallel load
L	L	X	H	X	no change
L	L	L	L	↑	count down
L	L	H	L	↑	count up
H	X	X	X	X	reset

[1] H = HIGH voltage level; L = LOW voltage level; X = don't care; ↑ = positive-going transition.

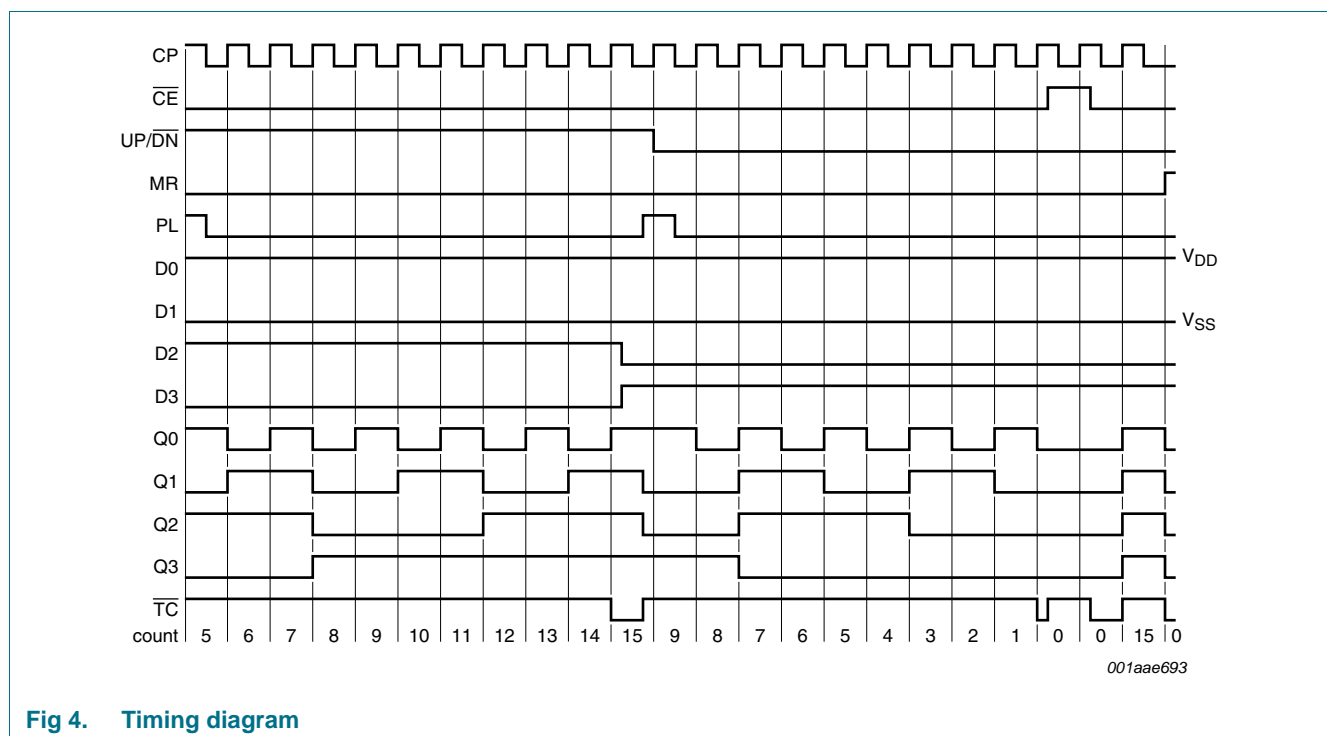
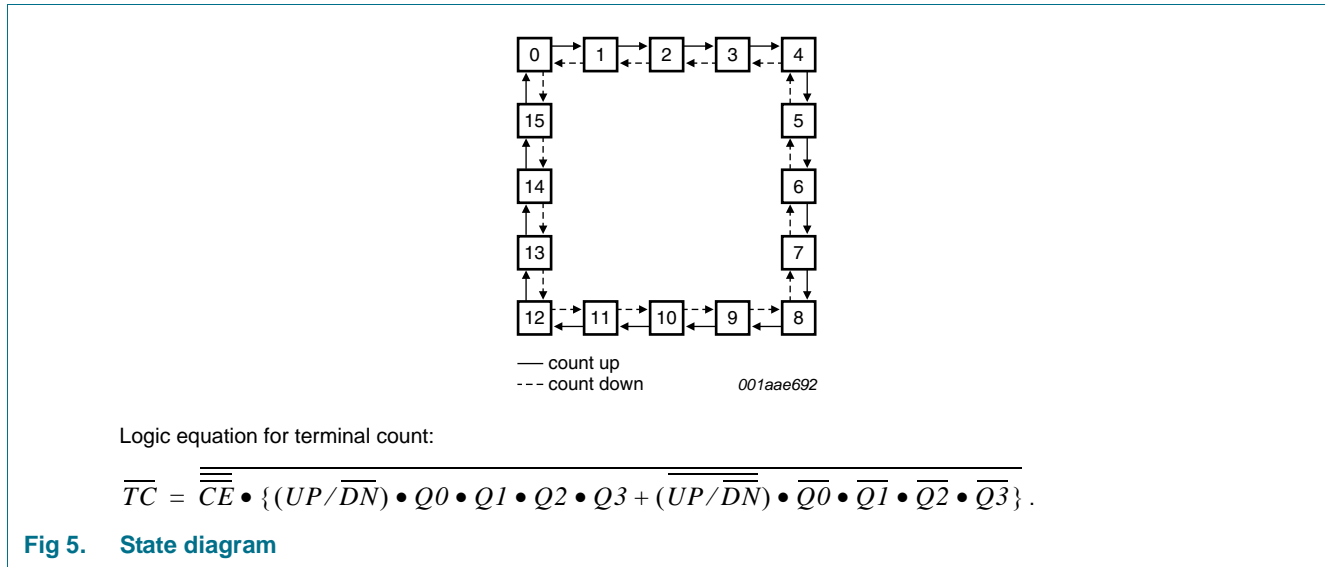

Fig 4. Timing diagram



8. Limiting values

Table 4. Limiting values

In accordance with the Absolute Maximum Rating System (IEC 60134).

Symbol	Parameter	Conditions	Min	Max	Unit
V _{DD}	supply voltage		-0.5	+18	V
I _{IK}	input clamping current	V _I < -0.5 V or V _I > V _{DD} + 0.5 V	-	±10	mA
V _I	input voltage		-0.5	V _{DD} + 0.5	V
I _{OK}	output clamping current	V _O < -0.5 V or V _O > V _{DD} + 0.5 V	-	±10	mA
I _{I/O}	input/output current		-	±10	mA
I _{DD}	supply current		-	50	mA
T _{stg}	storage temperature		-65	+150	°C
T _{amb}	ambient temperature		-40	+85	°C
P _{tot}	total power dissipation	DIP16 package	[1] -	750	mW
		SO16 package	[2] -	500	mW
P	power dissipation	per output	-	100	mW

[1] For DIP16 package: P_{tot} derates linearly with 12 mW/K above 70 °C.

[2] For SO16 package: P_{tot} derates linearly with 8 mW/K above 70 °C.

9. Recommended operating conditions

Table 5. Recommended operating conditions

Symbol	Parameter	Conditions	Min	Typ	Max	Unit
V _{DD}	supply voltage		3	-	15	V
V _I	input voltage		0	-	V _{DD}	V
T _{amb}	ambient temperature	in free air	-40	-	+85	°C

Table 5. Recommended operating conditions ...continued

Symbol	Parameter	Conditions	Min	Typ	Max	Unit
$\Delta t/\Delta V$	input transition rise and fall rate	$V_{DD} = 5\text{ V}$	-	-	3.75	$\mu\text{s/V}$
		$V_{DD} = 10\text{ V}$	-	-	0.5	$\mu\text{s/V}$
		$V_{DD} = 15\text{ V}$	-	-	0.08	$\mu\text{s/V}$

10. Static characteristics

Table 6. Static characteristics

$V_{SS} = 0\text{ V}$; $V_I = V_{SS}$ or V_{DD} unless otherwise specified.

Symbol	Parameter	Conditions	V_{DD}	$T_{amb} = -40\text{ }^\circ\text{C}$		$T_{amb} = 25\text{ }^\circ\text{C}$		$T_{amb} = 85\text{ }^\circ\text{C}$		Unit
				Min	Max	Min	Max	Min	Max	
V_{IH}	HIGH-level input voltage	$ I_O < 1\text{ }\mu\text{A}$	5 V	3.5	-	3.5	-	3.5	-	V
			10 V	7.0	-	7.0	-	7.0	-	V
			15 V	11.0	-	11.0	-	11.0	-	V
V_{IL}	LOW-level input voltage	$ I_O < 1\text{ }\mu\text{A}$	5 V	-	1.5	-	1.5	-	1.5	V
			10 V	-	3.0	-	3.0	-	3.0	V
			15 V	-	4.0	-	4.0	-	4.0	V
V_{OH}	HIGH-level output voltage	$ I_O < 1\text{ }\mu\text{A}$; $V_I = V_{SS}$ or V_{DD}	5 V	4.95	-	4.95	-	4.95	-	V
			10 V	9.95	-	9.95	-	9.95	-	V
			15 V	14.95	-	14.95	-	14.95	-	V
V_{OL}	LOW-level output voltage	$ I_O < 1\text{ }\mu\text{A}$; $V_I = V_{SS}$ or V_{DD}	5 V	-	0.05	-	0.05	-	0.05	V
			10 V	-	0.05	-	0.05	-	0.05	V
			15 V	-	0.05	-	0.05	-	0.05	V
I_{OH}	HIGH-level output current	$V_O = 2.5\text{ V}$	5 V	-1.7	-	-1.4	-	-1.1	-	mA
			5 V	-0.52	-	-0.44	-	-0.36	-	mA
			10 V	-1.3	-	-1.1	-	-0.9	-	mA
			15 V	-3.6	-	-3.0	-	-2.4	-	mA
I_{OL}	LOW-level output current	$V_O = 0.4\text{ V}$	5 V	0.52	-	0.44	-	0.36	-	mA
			10 V	1.3	-	1.1	-	0.9	-	mA
			15 V	3.6	-	3.0	-	2.4	-	mA
I_I	input leakage current	$V_{DD} = 15\text{ V}$	15 V	-	± 0.3	-	± 0.3	-	± 1.0	μA
I_{DD}	supply current	$I_O = 0\text{ A}$; $V_I = V_{SS}$ or V_{DD}	5 V	-	20	-	20	-	150	μA
			10 V	-	40	-	40	-	300	μA
			15 V	-	80	-	80	-	600	μA
C_I	input capacitance		-	-	-	-	7.5	-	-	pF

11. Dynamic characteristics

Table 7. Dynamic characteristics

$V_{SS} = 0\text{ V}$; $T_{amb} = 25\text{ °C}$; for test circuit see [Figure 8](#); unless otherwise specified.

Symbol	Parameter	Conditions	V_{DD}	Extrapolation formula	Min	Typ	Max	Unit
t_{PHL}	HIGH to LOW propagation delay	CP to Qn	5 V	[1] $118\text{ ns} + (0.55\text{ ns/pF})C_L$	-	145	290	ns
			10 V	$49\text{ ns} + (0.23\text{ ns/pF})C_L$	-	60	120	ns
			15 V	$37\text{ ns} + (0.16\text{ ns/pF})C_L$	-	45	90	ns
		CP to \overline{TC}	5 V	$233\text{ ns} + (0.55\text{ ns/pF})C_L$	-	260	525	ns
			10 V	$94\text{ ns} + (0.23\text{ ns/pF})C_L$	-	105	210	ns
			15 V	$67\text{ ns} + (0.16\text{ ns/pF})C_L$	-	75	150	ns
		PL to Qn	5 V	$98\text{ ns} + (0.55\text{ ns/pF})C_L$	-	125	255	ns
			10 V	$44\text{ ns} + (0.23\text{ ns/pF})C_L$	-	55	110	ns
			15 V	$32\text{ ns} + (0.16\text{ ns/pF})C_L$	-	40	85	ns
		PL to \overline{TC}	5 V	$223\text{ ns} + (0.55\text{ ns/pF})C_L$	-	250	500	ns
			10 V	$99\text{ ns} + (0.23\text{ ns/pF})C_L$	-	110	220	ns
			15 V	$72\text{ ns} + (0.16\text{ ns/pF})C_L$	-	80	160	ns
		\overline{CE} to \overline{TC}	5 V	$138\text{ ns} + (0.55\text{ ns/pF})C_L$	-	165	330	ns
			10 V	$54\text{ ns} + (0.23\text{ ns/pF})C_L$	-	65	135	ns
			15 V	$42\text{ ns} + (0.16\text{ ns/pF})C_L$	-	50	100	ns
		MR to Qn, \overline{TC}	5 V	$178\text{ ns} + (0.55\text{ ns/pF})C_L$	-	205	405	ns
			10 V	$54\text{ ns} + (0.23\text{ ns/pF})C_L$	-	65	130	ns
			15 V	$37\text{ ns} + (0.16\text{ ns/pF})C_L$	-	45	85	ns
t_{PLH}	LOW to HIGH propagation delay	CP to Qn	5 V	[1] $128\text{ ns} + (0.55\text{ ns/pF})C_L$	-	155	310	ns
			10 V	$54\text{ ns} + (0.23\text{ ns/pF})C_L$	-	65	130	ns
			15 V	$37\text{ ns} + (0.16\text{ ns/pF})C_L$	-	45	90	ns
		CP to \overline{TC}	5 V	$153\text{ ns} + (0.55\text{ ns/pF})C_L$	-	180	360	ns
			10 V	$64\text{ ns} + (0.23\text{ ns/pF})C_L$	-	75	150	ns
			15 V	$47\text{ ns} + (0.16\text{ ns/pF})C_L$	-	55	115	ns
		PL to Qn	5 V	$143\text{ ns} + (0.55\text{ ns/pF})C_L$	-	170	340	ns
			10 V	$59\text{ ns} + (0.23\text{ ns/pF})C_L$	-	70	140	ns
			15 V	$42\text{ ns} + (0.16\text{ ns/pF})C_L$	-	50	105	ns
		PL to \overline{TC}	5 V	$223\text{ ns} + (0.55\text{ ns/pF})C_L$	-	250	500	ns
			10 V	$99\text{ ns} + (0.23\text{ ns/pF})C_L$	-	110	220	ns
			15 V	$72\text{ ns} + (0.16\text{ ns/pF})C_L$	-	80	160	ns
		\overline{CE} to \overline{TC}	5 V	$118\text{ ns} + (0.55\text{ ns/pF})C_L$	-	145	290	ns
			10 V	$49\text{ ns} + (0.23\text{ ns/pF})C_L$	-	60	125	ns
			15 V	$37\text{ ns} + (0.16\text{ ns/pF})C_L$	-	45	95	ns
		MR to \overline{TC}	5 V	$198\text{ ns} + (0.55\text{ ns/pF})C_L$	-	225	450	ns
			10 V	$64\text{ ns} + (0.23\text{ ns/pF})C_L$	-	75	150	ns
			15 V	$42\text{ ns} + (0.16\text{ ns/pF})C_L$	-	50	100	ns

Table 7. Dynamic characteristics ...continued $V_{SS} = 0\text{ V}$; $T_{amb} = 25\text{ °C}$; for test circuit see [Figure 8](#); unless otherwise specified.

Symbol	Parameter	Conditions	V _{DD}	Extrapolation formula	Min	Typ	Max	Unit
t _t	transition time		5 V	[1] 10 ns + (1.00 ns/pF)C _L	-	60	120	ns
			10 V	9 ns + (0.42 ns/pF)C _L	-	30	60	ns
			15 V	6 ns + (0.28 ns/pF)C _L	-	20	40	ns
f _{max}	maximum frequency	see Figure 6	5 V		3	6	-	MHz
			10 V		7	14	-	MHz
			15 V		9	18	-	MHz
t _w	pulse width	CP input LOW; minimum width; see Figure 6	5 V		95	45	-	ns
			10 V		35	20	-	ns
			15 V		25	15	-	ns
		PL input HIGH; minimum width; see Figure 7	5 V		105	55	-	ns
			10 V		45	25	-	ns
			15 V		35	15	-	ns
		MR input HIGH; minimum width; see Figure 7	5 V		120	60	-	ns
			10 V		50	25	-	ns
			15 V		40	20	-	ns
t _{rec}	recovery time	MR input; see Figure 7	5 V		130	65	-	ns
			10 V		45	20	-	ns
			15 V		30	15	-	ns
		PL input; see Figure 7	5 V		150	75	-	ns
			10 V		50	25	-	ns
			15 V		30	15	-	ns
t _{su}	set-up time	Dn to PL; see Figure 7	5 V		100	50	-	ns
			10 V		50	25	-	ns
			15 V		40	20	-	ns
		UP/DN to CP; see Figure 6	5 V		250	125	-	ns
			10 V		100	50	-	ns
			15 V		75	35	-	ns
		CE to CP; see Figure 6	5 V		120	60	-	ns
			10 V		40	20	-	ns
			15 V		25	10	-	ns
t _h	hold time	Dn to PL; see Figure 7	5 V		+10	-40	-	ns
			10 V		+5	-20	-	ns
			15 V		0	-20	-	ns
		UP/DN to CP; see Figure 6	5 V		+35	-90	-	ns
			10 V		+15	-35	-	ns
			15 V		+15	-25	-	ns
		CE to CP; see Figure 6	5 V		+20	-40	-	ns
			10 V		+5	-15	-	ns
			15 V		+5	-10	-	ns

[1] The typical values of the propagation delay and transition times are calculated from the extrapolation formulas shown (C_L in pF).

Table 8. Dynamic power dissipation P_D

P_D can be calculated from the formulas shown. $V_{SS} = 0\text{ V}$; $C_L = 50\text{ pF}$; $t_r = t_f \leq 20\text{ ns}$; $T_{amb} = 25\text{ }^\circ\text{C}$.

Symbol	Parameter	V_{DD}	Typical formula for P_D (μW)	Where:
P_D	dynamic power dissipation	5 V	$P_D = 1000 \times f_i + \Sigma(f_o \times C_L) \times V_{DD}^2$	f_i = input frequency in MHz;
		10 V	$P_D = 4500 \times f_i + \Sigma(f_o \times C_L) \times V_{DD}^2$	f_o = output frequency in MHz;
		15 V	$P_D = 11200 \times f_i + \Sigma(f_o \times C_L) \times V_{DD}^2$	C_L = output load capacitance in pF; V_{DD} = supply voltage in V; $\Sigma(f_o \times C_L)$ = sum of the outputs.

12. Waveforms

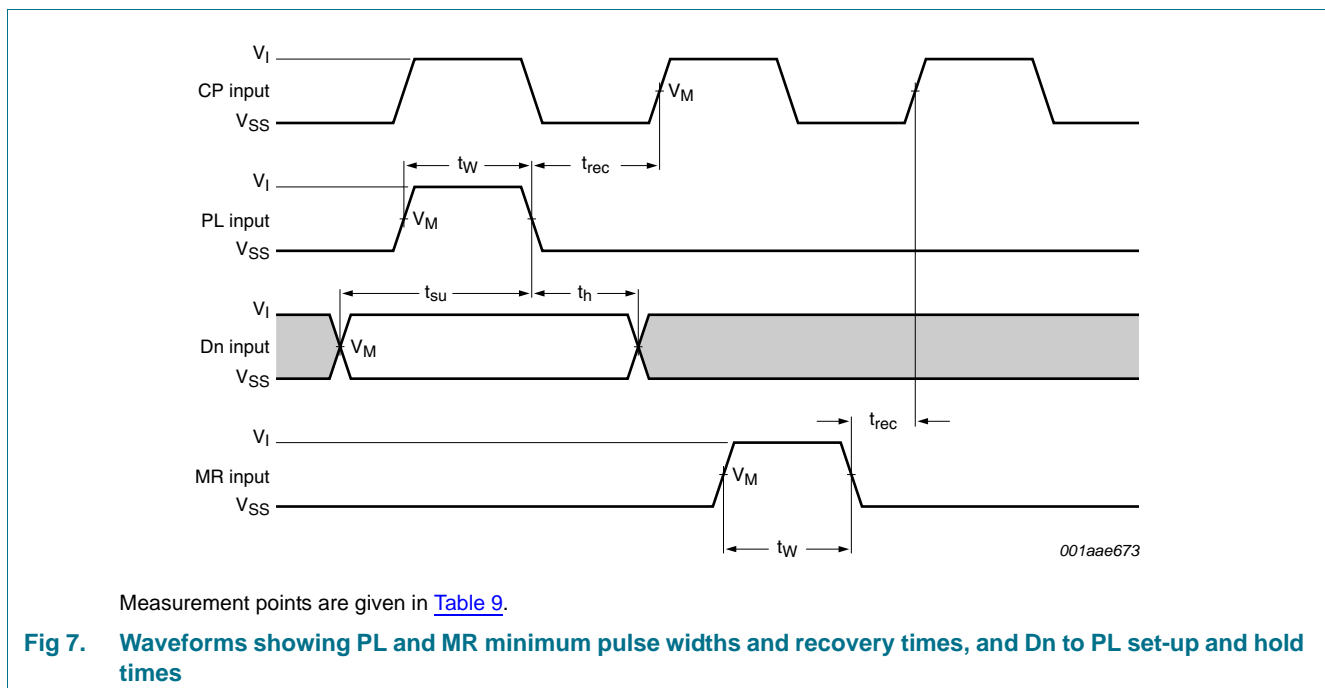
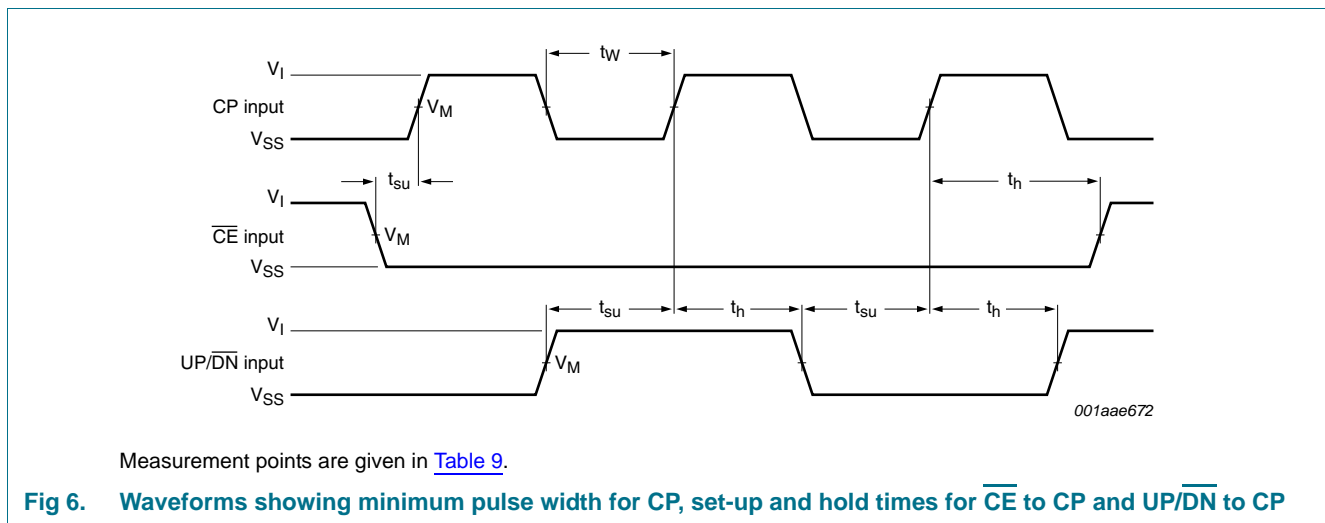

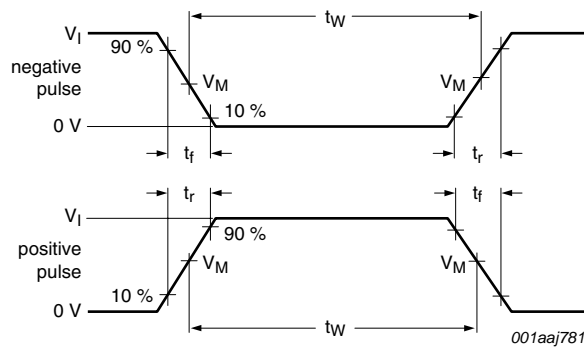

a. Input waveforms

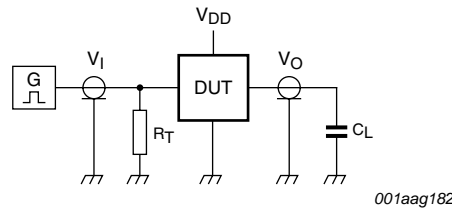

b. Test circuit

Test data is given in [Table 9](#).

Definitions for test circuit:

DUT = Device Under Test

C_L = Load capacitance including jig and probe capacitance;

R_T = Termination resistance should be equal to output impedance Z_o of the pulse generator.

Fig 8. Test circuit for measuring switching times

Table 9. Measurement points and test data

Supply voltage	Input			Load
	V_I	V_M	t_r, t_f	C_L
5 V to 15 V	V_{DD}	$0.5V_I$	≤ 20 ns	50 pF

13. Package outline

DIP16: plastic dual in-line package; 16 leads (300 mil)

SOT38-4

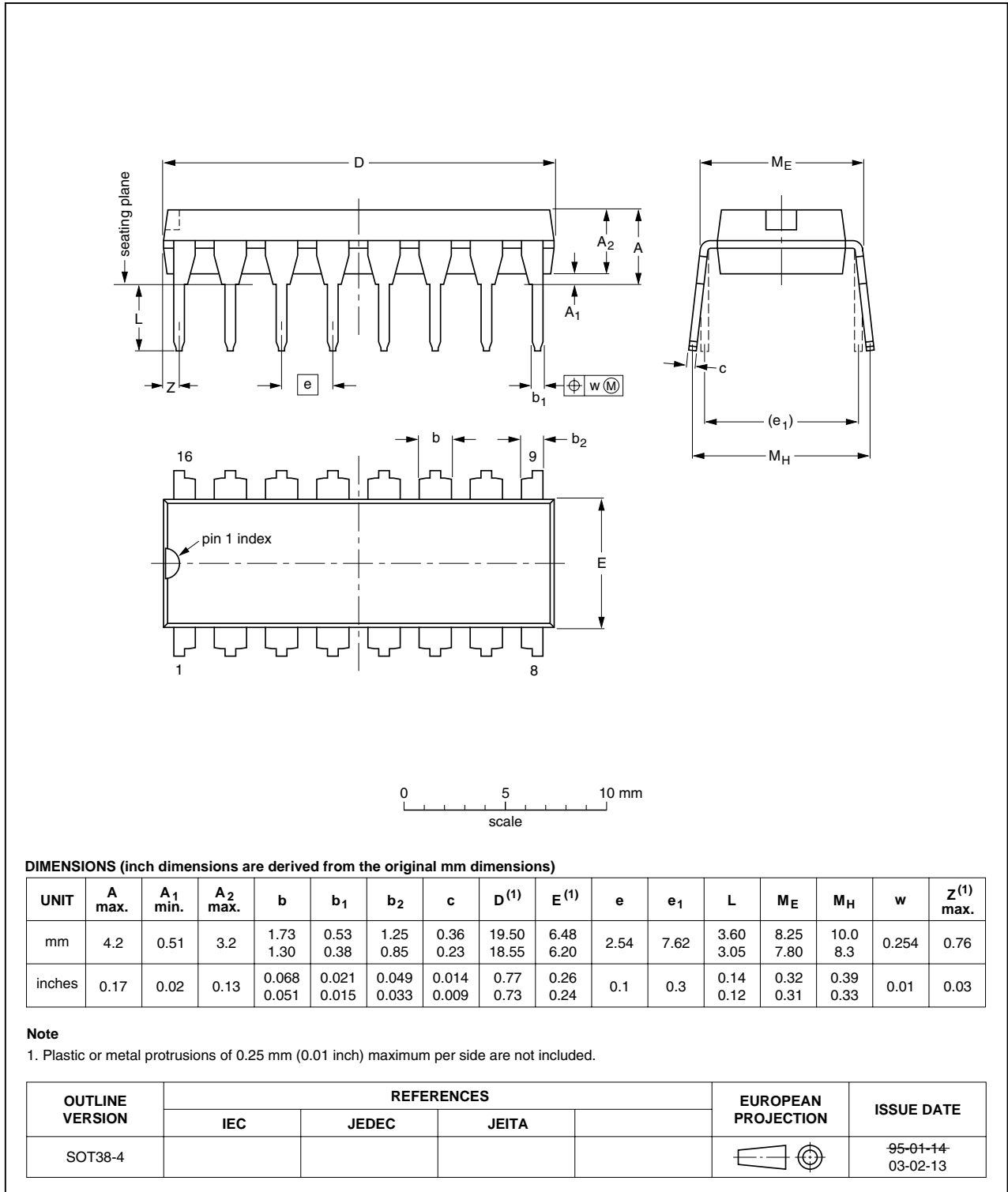

Fig 9. Package outline SOT38-4 (DIP16)

SO16: plastic small outline package; 16 leads; body width 3.9 mm

SOT109-1

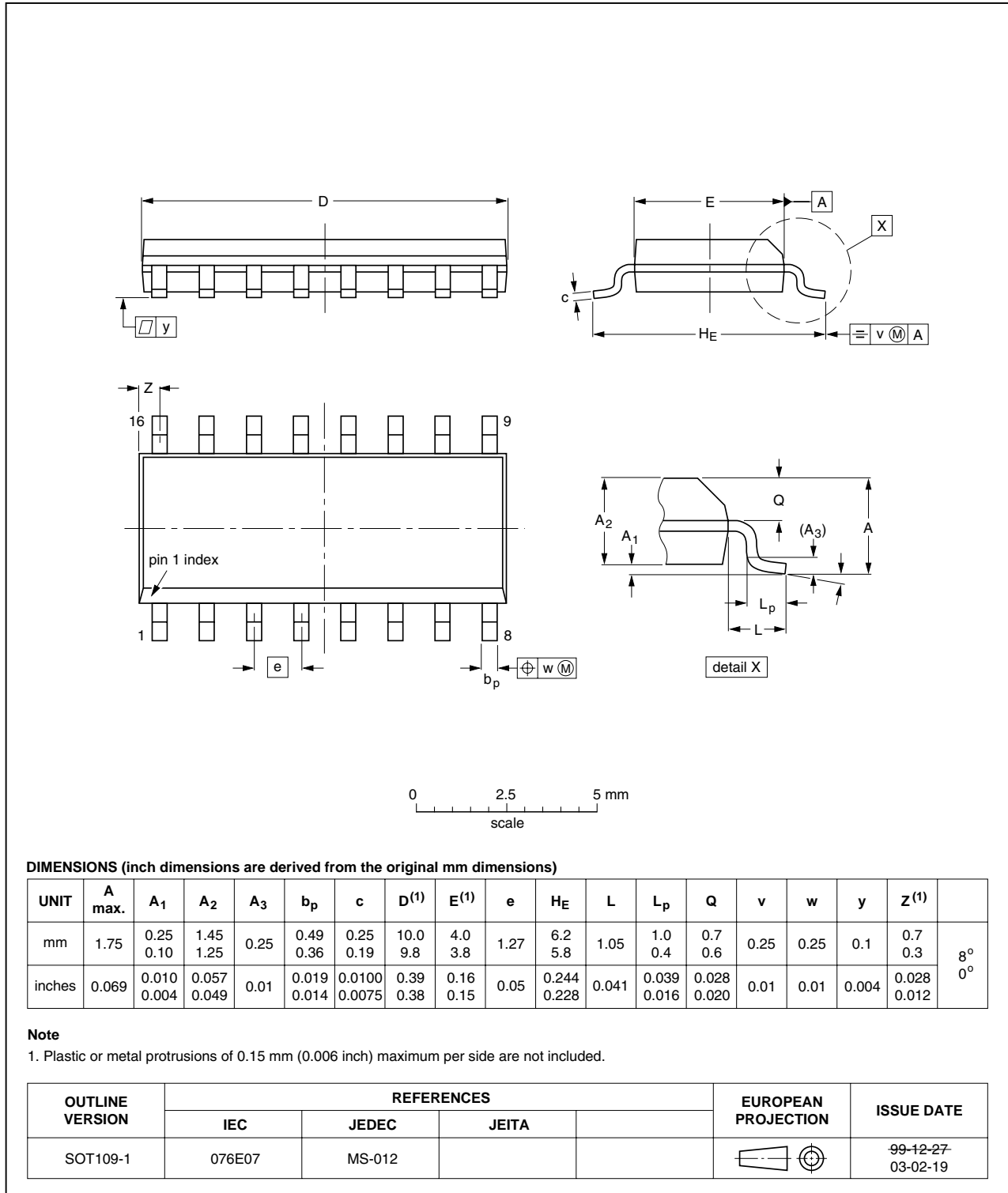

Fig 10. Package outline SOT109-1 (SO16)

14. Revision history

Table 10. Revision history

Document ID	Release date	Data sheet status	Change notice	Supersedes
HEF4516B_6	20091211	Product data sheet	-	HEF4516B_5
Modifications:	• Section 9 "Recommended operating conditions" $\Delta t/\Delta V$ values updated.			
HEF4516B_5	20090812	Product data sheet	-	HEF4516B_4
HEF4516B_4	20090312	Product data sheet	-	HEF4516B_CNV_3
HEF4516B_CNV_3	19950101	Product specification	-	HEF4516B_CNV_2
HEF4516B_CNV_2	19950101	Product specification	-	-

15. Legal information

15.1 Data sheet status

Document status ^{[1][2]}	Product status ^[3]	Definition
Objective [short] data sheet	Development	This document contains data from the objective specification for product development.
Preliminary [short] data sheet	Qualification	This document contains data from the preliminary specification.
Product [short] data sheet	Production	This document contains the product specification.

[1] Please consult the most recently issued document before initiating or completing a design.

[2] The term 'short data sheet' is explained in section "Definitions".

[3] The product status of device(s) described in this document may have changed since this document was published and may differ in case of multiple devices. The latest product status information is available on the Internet at URL <http://www.nxp.com>.

15.2 Definitions

Draft — The document is a draft version only. The content is still under internal review and subject to formal approval, which may result in modifications or additions. NXP Semiconductors does not give any representations or warranties as to the accuracy or completeness of information included herein and shall have no liability for the consequences of use of such information.

Short data sheet — A short data sheet is an extract from a full data sheet with the same product type number(s) and title. A short data sheet is intended for quick reference only and should not be relied upon to contain detailed and full information. For detailed and full information see the relevant full data sheet, which is available on request via the local NXP Semiconductors sales office. In case of any inconsistency or conflict with the short data sheet, the full data sheet shall prevail.

15.3 Disclaimers

General — Information in this document is believed to be accurate and reliable. However, NXP Semiconductors does not give any representations or warranties, expressed or implied, as to the accuracy or completeness of such information and shall have no liability for the consequences of use of such information.

Right to make changes — NXP Semiconductors reserves the right to make changes to information published in this document, including without limitation specifications and product descriptions, at any time and without notice. This document supersedes and replaces all information supplied prior to the publication hereof.

Suitability for use — NXP Semiconductors products are not designed, authorized or warranted to be suitable for use in medical, military, aircraft, space or life support equipment, nor in applications where failure or malfunction of an NXP Semiconductors product can reasonably be expected to result in personal injury, death or severe property or environmental

damage. NXP Semiconductors accepts no liability for inclusion and/or use of NXP Semiconductors products in such equipment or applications and therefore such inclusion and/or use is at the customer's own risk.

Applications — Applications that are described herein for any of these products are for illustrative purposes only. NXP Semiconductors makes no representation or warranty that such applications will be suitable for the specified use without further testing or modification.

Limiting values — Stress above one or more limiting values (as defined in the Absolute Maximum Ratings System of IEC 60134) may cause permanent damage to the device. Limiting values are stress ratings only and operation of the device at these or any other conditions above those given in the Characteristics sections of this document is not implied. Exposure to limiting values for extended periods may affect device reliability.

Terms and conditions of sale — NXP Semiconductors products are sold subject to the general terms and conditions of commercial sale, as published at <http://www.nxp.com/profile/terms>, including those pertaining to warranty, intellectual property rights infringement and limitation of liability, unless explicitly otherwise agreed to in writing by NXP Semiconductors. In case of any inconsistency or conflict between information in this document and such terms and conditions, the latter will prevail.

No offer to sell or license — Nothing in this document may be interpreted or construed as an offer to sell products that is open for acceptance or the grant, conveyance or implication of any license under any copyrights, patents or other industrial or intellectual property rights.

Export control — This document as well as the item(s) described herein may be subject to export control regulations. Export might require a prior authorization from national authorities.

15.4 Trademarks

Notice: All referenced brands, product names, service names and trademarks are the property of their respective owners.

16. Contact information

For more information, please visit: <http://www.nxp.com>

For sales office addresses, please send an email to: salesaddresses@nxp.com

17. Contents

1	General description	1
2	Features	1
3	Applications	1
4	Ordering information	1
5	Functional diagram	2
6	Pinning information	4
6.1	Pinning	4
6.2	Pin description	4
7	Functional description	5
8	Limiting values	6
9	Recommended operating conditions	6
10	Static characteristics	7
11	Dynamic characteristics	8
12	Waveforms	10
13	Package outline	12
14	Revision history	14
15	Legal information	15
15.1	Data sheet status	15
15.2	Definitions	15
15.3	Disclaimers	15
15.4	Trademarks	15
16	Contact information	15
17	Contents	16



Please be aware that important notices concerning this document and the product(s) described herein, have been included in section 'Legal information'.

© NXP B.V. 2009.

All rights reserved.

For more information, please visit: <http://www.nxp.com>

For sales office addresses, please send an email to: salesaddresses@nxp.com

Date of release: 11 December 2009

Document identifier: HEF4516B_6