



# ±15kV ESD-Protected, 1μA, 250kbps, 3.3V/5V, Dual RS-232 Transceivers with Internal Capacitors

## General Description

The MAX3233E/MAX3235E are EIA/TIA-232 and V.28/V.24 communications interfaces with automatic shutdown/wake-up features, high data-rate capabilities, and enhanced electrostatic discharge (ESD) protection. All transmitter outputs and receiver inputs are protected to ±15kV using IEC 1000-4-2 Air-Gap Discharge, to ±8kV using IEC 1000-4-2 Contact Discharge, and to ±15kV using the Human Body Model. The MAX3233E operates from a +3.3V supply; the MAX3235E operates from +5.0V.

All devices achieve a 1μA supply current using Maxim's revolutionary AutoShutdown Plus™ feature. These devices automatically enter a low-power shutdown mode when the following two conditions occur: either the RS-232 cable is disconnected or the transmitters of the connected peripherals are inactive, and the UART driving the transmitter inputs is inactive for more than 30 seconds. They turn on again when they sense a valid transition at any transmitter or receiver input. AutoShutdown Plus saves power without changes to the existing BIOS or operating system.

The MAX3233E/MAX3235E have internal dual charge pumps requiring no external capacitors. Both transceivers have a proprietary low-dropout transmitter output stage that enables true RS-232 performance from a +3.0V to +3.6V supply for the MAX3233E or a +4.5V to +5.5V supply for the MAX3235E. These devices are guaranteed to operate up to 250kbps. Both are available in space-saving 20-pin wide SO or plastic DIP packages.

## Applications

Subnotebook and Palmtop Computers  
Cellular Phones  
Battery-Powered Equipment  
Hand-Held Equipment  
Peripherals  
Embedded Systems

## Ordering Information

PART	TEMP. RANGE	PIN-PACKAGE
MAX3233ECWP	0°C to +70°C	20 SO
MAX3233ECPD	0°C to +70°C	20 Plastic DIP
MAX3233EEWP	-40°C to +85°C	20 SO
MAX3233EEDD	-40°C to +85°C	20 Plastic DIP

Ordering Information continued at end of data sheet.

AutoShutdown Plus is a trademark of Maxim Integrated Products.

† Covered by U.S. Patent numbers 4,636,930; 4,679,134; 4,777,577; 4,797,899; 4,809,152; 4,897,774; 4,999,761; 5,649,210; and other patents pending.



Maxim Integrated Products 1

For free samples & the latest literature: <http://www.maxim-ic.com>, or phone 1-800-998-8800.  
For small orders, phone 1-800-835-8769.

## Features

- ◆ ESD Protection for RS-232 I/O Pins
  - ±15kV—Human Body Model
  - ±8kV—IEC 1000-4-2, Contact Discharge
  - ±15kV—IEC 1000-4-2, Air-Gap Discharge
- ◆ Latchup Free
- ◆ 1μA Supply Current
- ◆ AutoShutdown Plus—1997 EDN Magazine Innovation of the Year
- ◆ Single-Supply Operation
  - +3.0V to +3.6V (MAX3233E)
  - +4.5V to +5.5V (MAX3235E)
- ◆ 250kbps Guaranteed Data Rate
- ◆ 6V/μs Guaranteed Slew Rate
- ◆ Meets EIA/TIA-232 Specifications Down to 3.0V (MAX3233E)
- ◆ Internal Charge-Pump Capacitors

## Pin Configuration/ Functional Diagram

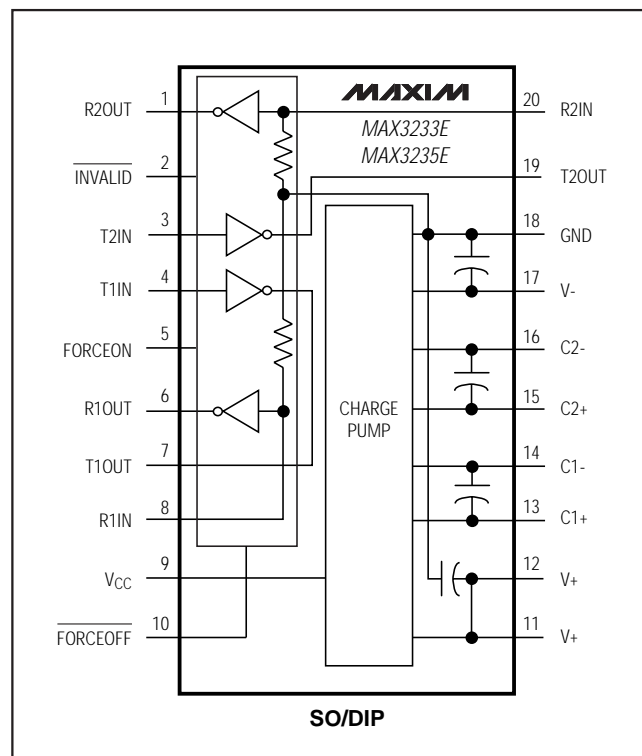

Typical Operating Circuit appears at end of data sheet.

MAX3233E†/MAX3235E†

# ±15kV ESD-Protected, 1µA, 250kbps, 3.3V/5V, Dual RS-232 Transceivers with Internal Capacitors

## ABSOLUTE MAXIMUM RATINGS

V <sub>CC</sub> to GND (MAX3233E).....	-0.3V to +4V	Short-Circuit Duration	
V <sub>CC</sub> to GND (MAX3235E).....	-0.3V to +6V	T <sub>OUT</sub> to GND .....	Continuous
V <sub>+</sub> to GND (Note 1).....	-0.3V to +7V	Continuous Power Dissipation (T <sub>A</sub> = +70°C)	
V <sub>-</sub> to GND (Note 1).....	+0.3V to -7V	Wide SO (derate 10mW/°C above +70°C).....	800mW
V <sub>+</sub> +  V <sub>-</sub>   (Note 1).....	+13V	Plastic DIP (derate 11.11mW/°C above +70°C) .....	889mW
Input Voltages		Operating Temperature Ranges	
T <sub>IN</sub> , FORCEON, FORCEOFF to GND.....	-0.3V to +6V	MAX323_EC_P.....	0°C to +70°C
R <sub>IN</sub> to GND.....	±25V	MAX323_EE_P.....	-40°C to +85°C
Output Voltages		Storage Temperature Range.....	-65°C to +150°C
T <sub>OUT</sub> to GND.....	±13.2V	Lead Temperature (soldering, 10sec).....	+300°C
R <sub>OUT</sub> , INVALID to GND .....	-0.3V to (V <sub>CC</sub> + 0.3V)		

**Note 1:** V<sub>+</sub> and V<sub>-</sub> can have maximum magnitudes of 7V, but their absolute difference cannot exceed 13V.

Stresses beyond those listed under "Absolute Maximum Ratings" may cause permanent damage to the device. These are stress ratings only, and functional operation of the device at these or any other conditions beyond those indicated in the operational sections of the specifications is not implied. Exposure to absolute maximum rating conditions for extended periods may affect device reliability.

## ELECTRICAL CHARACTERISTICS

(V<sub>CC</sub> = +3.0V to +3.6V for MAX3233E, V<sub>CC</sub> = +4.5V to +5.5V for MAX3235E; T<sub>A</sub> = T<sub>MIN</sub> to T<sub>MAX</sub>; unless otherwise noted. Typical values are at T<sub>A</sub> = +25°C.)

PARAMETER	SYMBOL	CONDITIONS	MIN	TYP	MAX	UNITS
<b>DC CHARACTERISTICS</b> (V <sub>CC</sub> = 3.3V for MAX3233E, V <sub>CC</sub> = 5.0V for MAX3235E, T <sub>A</sub> = +25°C.)						
Supply Current, AutoShutdown Plus		FORCEON = GND, FORCEOFF = V <sub>CC</sub> , all R <sub>IN</sub> idle, all T <sub>IN</sub> idle		1	10	µA
Supply Current, Shutdown		FORCEOFF = GND		1	10	µA
Supply Current, AutoShutdown Plus Disabled		FORCEON = FORCEOFF = V <sub>CC</sub> , no load		0.3	1	mA
<b>LOGIC INPUTS AND RECEIVER OUTPUTS</b>						
Input Logic Threshold Low		T <sub>IN</sub> , FORCEON, FORCEOFF			0.8	V
Input Logic Threshold High		T <sub>IN</sub> , FORCEON, FORCEOFF	V <sub>CC</sub> = 3.3V, MAX3233E	2		V
			V <sub>CC</sub> = 5.0V, MAX3235E	2.4		V
Transmitter Input Hysteresis				0.5		V
Input Leakage Current		T <sub>IN</sub> , FORCEON, FORCEOFF		±0.01	±1	µA
Output Voltage Low		I <sub>OUT</sub> = 1.6mA			0.4	V
Output Voltage High		I <sub>OUT</sub> = -1.0mA	V <sub>CC</sub> - 0.6	V <sub>CC</sub> - 0.1		V
<b>RECEIVER INPUTS</b>						
Input Voltage Range			-25		+25	V
Input Threshold Low		T <sub>A</sub> = +25°C	V <sub>CC</sub> = 3.3V, MAX3233E	0.6	1.0	V
			V <sub>CC</sub> = 5.0V, MAX3235E	0.8	1.3	V
Input Threshold High		T <sub>A</sub> = +25°C	V <sub>CC</sub> = 3.3V, MAX3233E	1.5	2.4	V
			V <sub>CC</sub> = 5.0V, MAX3235E	1.8	2.4	V
Input Hysteresis				0.5		V
Input Resistance		T <sub>A</sub> = +25°C	3	5	7	kΩ

# ±15kV ESD-Protected, 1μA, 250kbps, 3.3V/5V, Dual RS-232 Transceivers with Internal Capacitors

MAX3233E/MAX3235E

## ELECTRICAL CHARACTERISTICS (continued)

(V<sub>CC</sub> = +3.0V to +3.6V for MAX3233E, V<sub>CC</sub> = +4.5V to +5.5V for MAX3235E; T<sub>A</sub> = T<sub>MIN</sub> to T<sub>MAX</sub>; unless otherwise noted. Typical values are at T<sub>A</sub> = +25°C.)

PARAMETER	SYMBOL	CONDITIONS		MIN	TYP	MAX	UNITS
<b>TRANSMITTER OUTPUTS</b>							
Output Voltage Swing		All transmitter outputs loaded with 3kΩ to ground		±5	±5.4		V
Output Resistance		V <sub>CC</sub> = V <sub>+</sub> = V <sub>-</sub> = 0, transmitter outputs = ±2V		300	10M		Ω
Output Short-Circuit Current						±60	mA
Output Leakage Current		V <sub>OUT</sub> = ±12V transmitters disabled	V <sub>CC</sub> = 0 or +3.0V to 3.6V (MAX3233E)			±25	μA
			V <sub>CC</sub> = 0 or +4.5V to 5.5V (MAX3235E)			±25	
<b>ESD PROTECTION</b>							
R <sub>IN</sub> , T <sub>OUT</sub>		IEC1000-4-2 Air Discharge			±15		kV
		IEC1000-4-2 Contact Discharge			±8		
		Human Body Model			±15		
<b>AutoShutdown PLUS</b> (FORCEON = GND, FORCEOFF = V <sub>CC</sub> )							
Receiver Input Threshold to <u>INVALID</u> Output High		Figure 3a	Positive threshold			2.7	V
			Negative threshold			-2.7	
Receiver Input Threshold to <u>INVALID</u> Output Low		Figure 3a		-0.3		0.3	V
<u>INVALID</u> Output Voltage Low		I <sub>OUT</sub> = -1.6mA				0.4	V
<u>INVALID</u> , Output Voltage High		I <sub>OUT</sub> = -1.0mA		V <sub>CC</sub> - 0.6			V
Receiver Positive or Negative Threshold to <u>INVALID</u> High	t <sub>INVH</sub>	Figure 3b			1		μs
Receiver Positive or Negative Threshold to <u>INVALID</u> Low	t <sub>INVL</sub>	Figure 3b	MAX3233E		70		μs
			MAX3235E		50		
Receiver or Transmitter Edge to Transmitters Enabled	t <sub>WU</sub>	Figure 3b (Note 2)			100		μs
Receiver or Transmitter Edge to Transmitters Shut Down	t <sub>AUTOSHDN</sub>	Figure 3b (Note 2)		15	30	60	sec

# ±15kV ESD-Protected, 1μA, 250kbps, 3.3V/5V, Dual RS-232 Transceivers with Internal Capacitors

## TIMING CHARACTERISTICS (continued)

(V<sub>CC</sub> = +3.0V to +3.6V for MAX3233E, V<sub>CC</sub> = +4.5V to +5.5V for MAX3235E; T<sub>A</sub> = T<sub>MIN</sub> to T<sub>MAX</sub>; unless otherwise noted. Typical values are at T<sub>A</sub> = +25°C.)

PARAMETER	SYMBOL	CONDITIONS	MIN	TYP	MAX	UNITS	
Maximum Data Rate		R <sub>L</sub> = 3kΩ, C <sub>L</sub> = 1000pF, one transmitter switching	250			kbps	
Receiver Propagation Delay	t <sub>PHL</sub>	R <sub>IN</sub> to R <sub>OUT</sub> , C <sub>L</sub> = 150pF	MAX3233E	70		ns	
			MAX3235E	100			
	MAX3233E		250				
	MAX3235E		150				
Receiver Output Enable Time		Normal operation		200		ns	
Receiver Output Disable Time		Normal operation		200		ns	
Transmitter Skew	t <sub>PHL</sub> - t <sub>PLH</sub>	(Note 3)		150		ns	
Receiver Skew	t <sub>PHL</sub> - t <sub>PLH</sub>	MAX3233E		180		ns	
		MAX3235E		50			
Transition-Region Slew Rate		V <sub>CC</sub> = 3.3V (MAX3233E), V <sub>CC</sub> = 5.0V (MAX3235E), T <sub>A</sub> = +25°C, R <sub>L</sub> = 3kΩ to 7kΩ, measured from +3V to -3V or -3V to +3V	C <sub>L</sub> = 150pF to 1000pF	6		30	V/μs
			C <sub>L</sub> = 150pF to 2500pF	4		30	

## Typical Operating Characteristics

(V<sub>CC</sub> = +3.3V for MAX3233E, V<sub>CC</sub> = +5.0V for MAX3235E; 250kbps data rate; all transmitters loaded with 3kΩ and C<sub>L</sub>; T<sub>A</sub> = +25°C; unless otherwise noted.)

**TRANSMITTER OUTPUT VOLTAGE vs. LOAD CAPACITANCE**

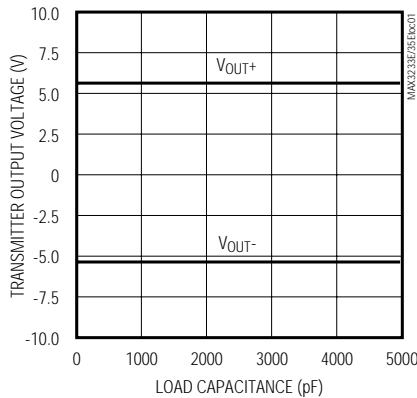

**OPERATING SUPPLY CURRENT vs. LOAD CAPACITANCE**

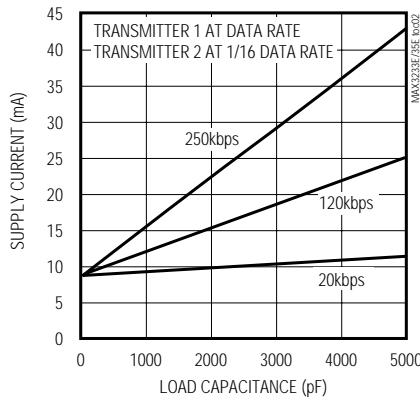

**SLEW RATE vs. LOAD CAPACITANCE**

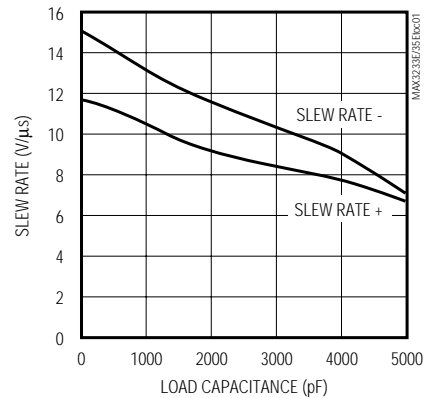

# ±15kV ESD-Protected, 1μA, 250kbps, 3.3V/5V, Dual RS-232 Transceivers with Internal Capacitors

## Pin Description

MAX3233E/MAX3235E

PIN	NAME	FUNCTION
1	R2OUT	TTL/CMOS Receiver Outputs
6	R1OUT	
2	$\overline{\text{INVALID}}$	Invalid Signal Detector Output, active low. A logic high indicates that a valid RS-232 level is present on a receiver.
3	T2N	TTL/CMOS Transmitter Outputs
4	T1IN	
5	FORCEON	Force-On Input, active high. Drive high to override AutoShutdown Plus, keeping transmitters and receivers active (FORCEOFF must be high) (Table 1).
7	T1OUT	RS-232 Transmitter Outputs
19	T2OUT	
8	R1IN	RS-232 Receiver Outputs
20	R2IN	
9	V <sub>CC</sub>	Supply Voltage (MAX3233E = +3.3V, MAX3235E = +5.0V)
10	$\overline{\text{FORCEOFF}}$	Force-Off Input, active low. Drive low to shut down transmitters, receivers, and charge pump. This overrides AutoShutdown Plus and FORCEON (Table 1).
11, 12	V+	+5.5V generated by the charge pump. Do not connect.
13	C1+	Positive terminal of the internal voltage-doubling charge-pump capacitor. Leave unconnected or connect to an external 0.1μF capacitor. See <i>Charge Pump</i> Section.
14	C1-	Negative terminal of the internal voltage-doubling charge-pump capacitor. Leave unconnected or connect to an external 0.1μF capacitor. See <i>Charge Pump</i> Section.
15	C2+	Positive terminal of the internal inverting charge-pump capacitor. Do not connect.
16	C2-	Negative terminal of the internal inverting charge-pump capacitor. Do not connect.
17	V-	-5.5V generated by the charge pump. Do not connect.
18	GND	Ground

# $\pm 15\text{kV}$ ESD-Protected, $1\mu\text{A}$ , 250kbps, 3.3V/5V, Dual RS-232 Transceivers with Internal Capacitors

## Detailed Description

### Dual Charge-Pump Voltage Converter

The MAX3233E/MAX3235E's internal power supply consists of a regulated dual charge pump that provides output voltages of +5.5V (doubling charge pump) and -5.5V (inverting charge pump), with no external capacitors. The charge pump operates in discontinuous mode: if the output voltages are less than 5.5V, the charge pump is enabled; if the output voltages exceed 5.5V, the charge pump is disabled.

### RS-232 Transmitters

The transmitters are inverting level translators that convert CMOS-logic levels to 5.0V EIA/TIA-232 levels. The devices guarantee a 250kbps data rate with worst-case loads of  $3\text{k}\Omega$  in parallel with 1000pF, providing compatibility with PC-to-PC communication software (such as LapLink™). Transmitters can be paralleled to drive multiple receivers. Figure 1 shows a complete system connection.

When  $\overline{\text{FORCEOFF}}$  is driven to ground or when the Auto-Shutdown Plus circuitry senses that all receiver and transmitter inputs are inactive for more than 30sec, the transmitters are disabled and the outputs go into a high-impedance state. When powered off or shut down, the outputs can be driven to  $\pm 12\text{V}$ . The transmitter inputs do not have pull-up resistors. Connect unused inputs to GND or Vcc.

### RS-232 Receivers

The receivers convert RS-232 signals to CMOS-logic output levels. They feature inverting outputs that always remain active (Table 1).

The MAX3233E/MAX3235E feature an  $\overline{\text{INVALID}}$  output that is enabled low when no valid RS-232 voltage levels have been detected on all receiver inputs. Because  $\overline{\text{INVALID}}$  indicates the receiver input's condition, it is independent of  $\text{FORCEON}$  and  $\overline{\text{FORCEOFF}}$  states (Figures 2 and 3).

### AutoShutdown Plus Mode

The devices achieve a  $1\mu\text{A}$  supply current with Maxim's AutoShutdown Plus feature, which operates when  $\overline{\text{FORCEOFF}}$  is high and a  $\text{FORCEON}$  is low. When these devices do not sense a valid signal transition on any receiver or transmitter input for 30sec, the on-board charge pumps are shut down, reducing supply current to  $1\mu\text{A}$ . This occurs if the RS-232 cable is disconnected, or if the connected peripheral transmitters are turned off and the UART driving the transmitter inputs is inactive. The system turns on again when a valid transition is

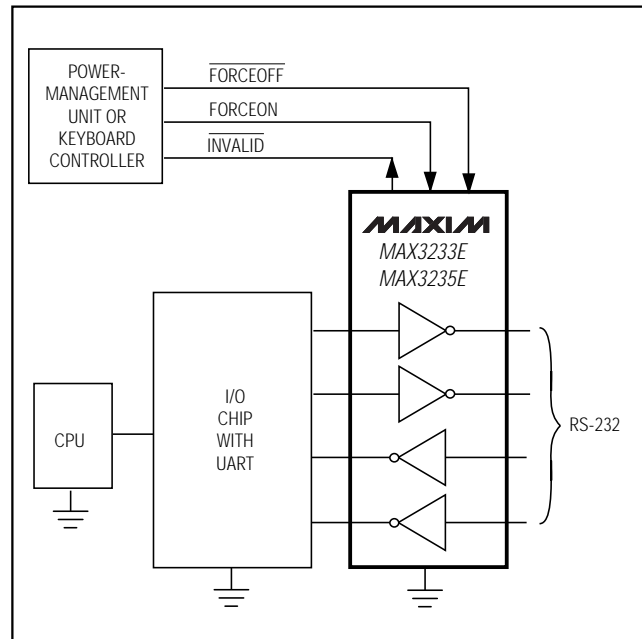

Figure 1. Interface Under Control of PMU

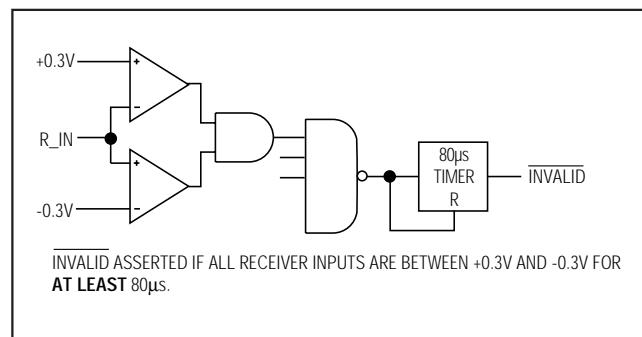

Figure 2a.  $\overline{\text{INVALID}}$  Functional Diagram,  $\overline{\text{INVALID}}$  Low

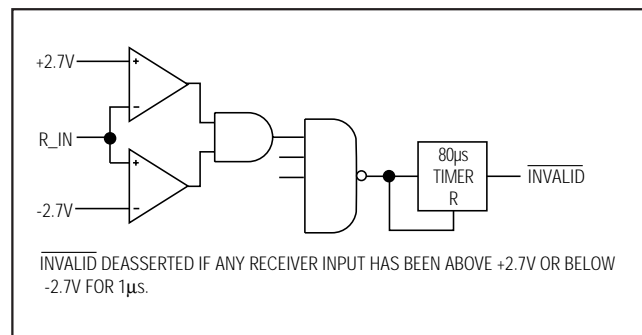

Figure 2b.  $\overline{\text{INVALID}}$  Functional Diagram,  $\overline{\text{INVALID}}$  High

LapLink is a trademark of Traveling Software.

# ±15kV ESD-Protected, 1µA, 250kbps, 3.3V/5V, Dual RS-232 Transceivers with Internal Capacitors

**Table 1. Output Control Truth Table**

OPERATION STATUS	FORCEON	$\overline{\text{FORCEOFF}}$	VALID RECEIVER LEVEL	Rx or Tx EDGE WITHIN 30sec	T_OUT	R_OUT
Shutdown (Forced Off)	X	0	X	X	High-Z	Active
Normal Operation (Forced On)	1	1	X	X	Active	Active
Normal Operation (AutoShutdown Plus)	0	1	X	Yes	Active	Active
Shutdown (AutoShutdown Plus)	0	1	X	No	High-Z	Active
Normal Operation	$\overline{\text{INVALID}}^*$	1	Yes	X	Active	Active
Normal Operation	$\overline{\text{INVALID}}^*$	1	X	Yes	Active	Active
Shutdown	$\overline{\text{INVALID}}^*$	1	No	No	High-Z	Active
Normal Operation (AutoShutdown)	$\overline{\text{INVALID}}^*$	$\overline{\text{INVALID}}^{**}$	Yes	X	Active	Active
Shutdown (AutoShutdown)	$\overline{\text{INVALID}}^*$	$\overline{\text{INVALID}}^{**}$	No	X	High-Z	Active

X = Don't care

\*  $\overline{\text{INVALID}}$  connected to FORCEON

\*\*  $\overline{\text{INVALID}}$  connected to FORCEON and  $\overline{\text{FORCEOFF}}$

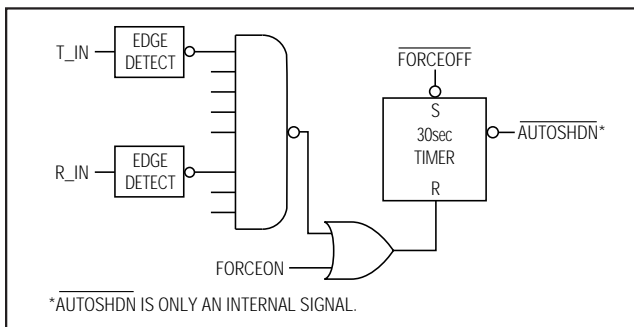

Figure 2c. AutoShutdown Plus Logic

applied to any RS-232 receiver or transmitter input. As a result, the system saves power without changes to the existing BIOS or operating system.

Figures 2a and 2b depict invalid and valid RS-232 receiver voltage levels.  $\overline{\text{INVALID}}$  indicates the receiver input's condition, and is independent of FORCEON and  $\overline{\text{FORCEOFF}}$  states. Figure 2 and Tables 1 and 2 summarize the operating modes. FORCEON and  $\overline{\text{FORCE}}$

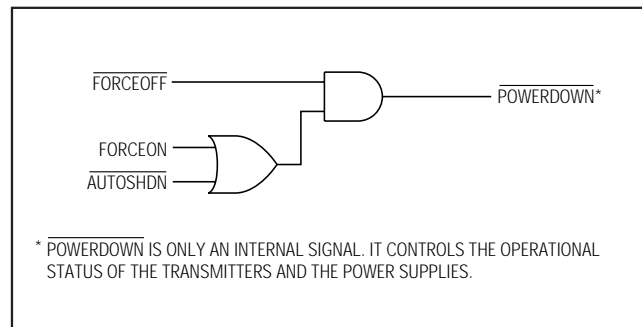

Figure 2d. Power-Down Logic

$\overline{\text{OFF}}$  override AutoShutdown Plus circuitry. When neither control is asserted, the IC selects between these states automatically based on the last receiver or transmitter input edge received.

When shut down, the device's charge pumps turn off, V+ is pulled to VCC, V- is pulled to ground, and the transmitter outputs are high impedance. The time required to exit shutdown is typically 100µs (Figure 7).

# ±15kV ESD-Protected, 1µA, 250kbps, 3.3V/5V, Dual RS-232 Transceivers with Internal Capacitors

By connecting FORCEON to  $\overline{\text{INVALID}}$ , the device shuts down when no valid receiver level and no receiver or transmitter edge is detected for 30sec. It wakes up when a valid receiver level or receiver or transmitter edge is detected.

By connecting FORCEON and  $\overline{\text{FORCEOFF}}$  to  $\overline{\text{INVALID}}$ , the device shuts down when no valid receiver level is detected and wakes up when a valid receiver level is detected.

A system with AutoShutdown Plus may need time to wake up. Figure 4 shows a circuit that forces the transmitters on for 100ms, allowing enough time for another system to realize that the MAX3233E/

MAX3235E is awake. If another system outputs valid RS-232 signal transitions within that time, the RS-232 ports on both systems remain enabled.

### Software-Controlled Shutdown

If direct software control is desired, use  $\overline{\text{INVALID}}$  to indicate DTR or Ring Indicator signal. Tie  $\overline{\text{FORCEOFF}}$  and FORCEON together to bypass the AutoShutdown Plus so the line acts like a  $\overline{\text{SHDN}}$  input.

### ±15kV ESD Protection

As with all Maxim devices, ESD-protection structures are incorporated on all pins to protect against electrostatic discharges encountered during handling and assembly. The driver outputs and receiver inputs have extra protection against static electricity. Maxim's engineers have developed state-of-the-art structures to protect these pins against ESD of ±15kV without damage. The ESD structures withstand high ESD in all states: normal operation, shutdown, and powered down. After an ESD

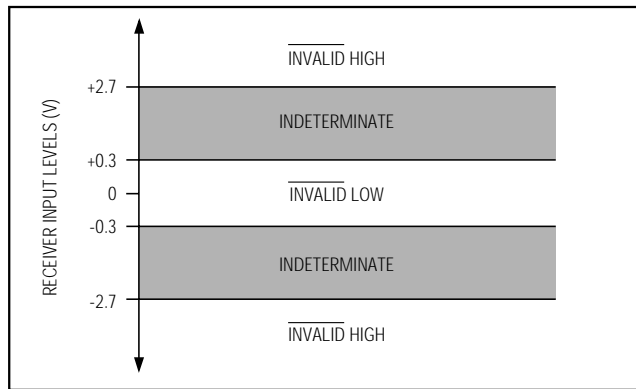

Figure 3a. Receiver Positive/Negative Thresholds for  $\overline{\text{INVALID}}$

Table 2.  $\overline{\text{INVALID}}$  Truth Table

RS-232 SIGNAL PRESENT AT ANY RECEIVER INPUT	$\overline{\text{INVALID}}$ OUTPUT
Yes	High
No	Low

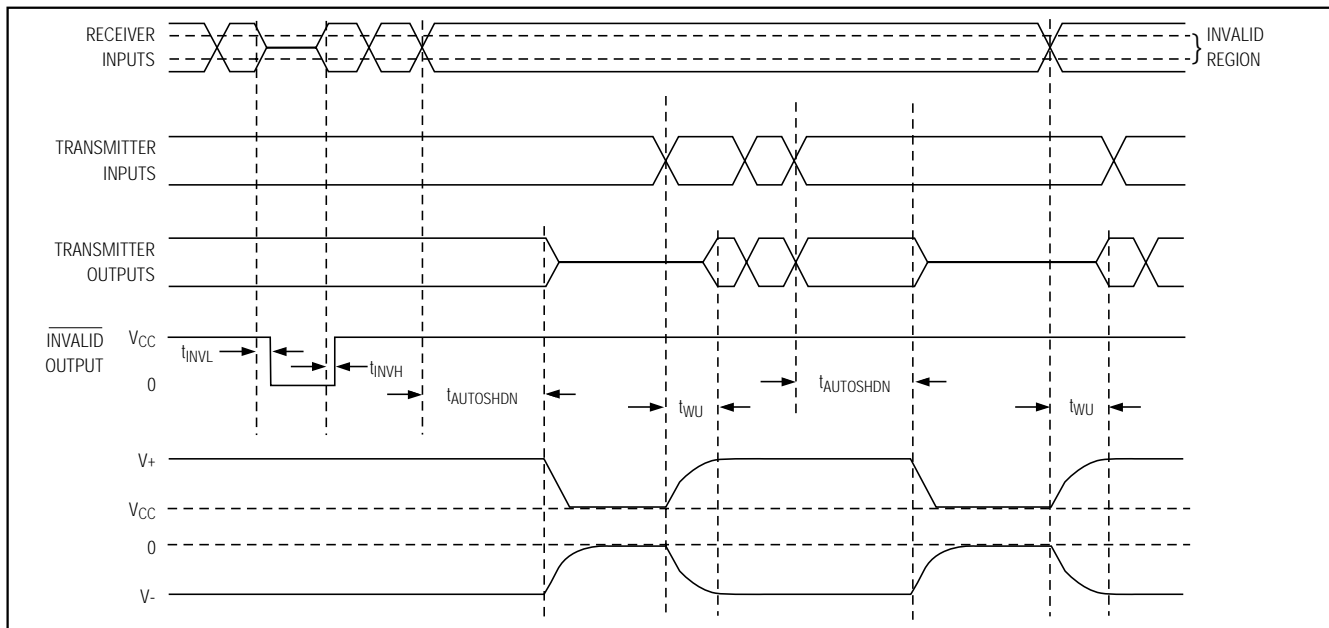

Figure 3b. AutoShutdown Plus,  $\overline{\text{INVALID}}$ , and READY Timing Diagram



# ±15kV ESD-Protected, 1µA, 250kbps, 3.3V/5V, Dual RS-232 Transceivers with Internal Capacitors

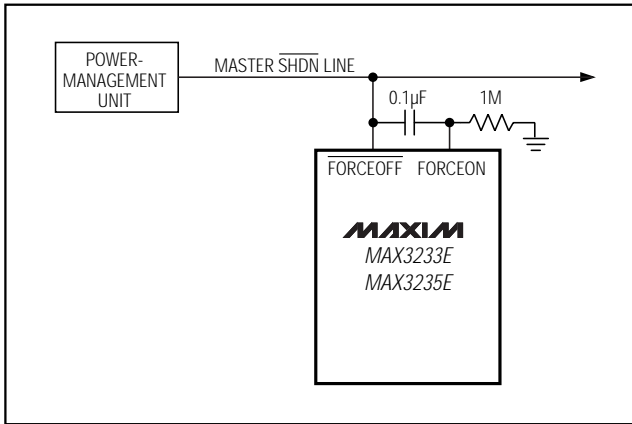

Figure 4. AutoShutdown Plus Initial Turn-On to Wake Up Another System

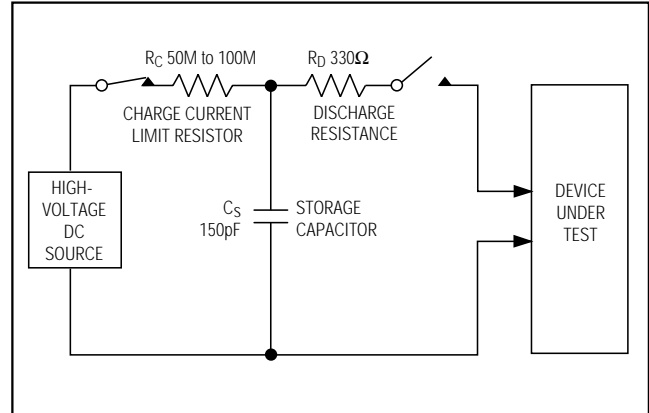

Figure 6a. IEC 1000-4-2 ESD Test Model

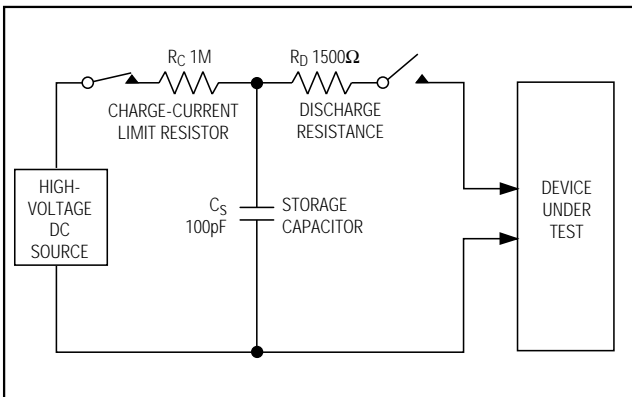

Figure 5a. Human Body ESD Test Model

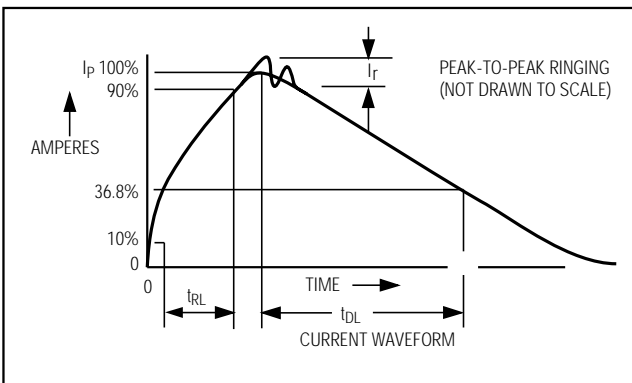

Figure 5b. Human Body Current Waveform

event, Maxim's E versions keep working without latchup, whereas competing RS-232 products can latch and must be powered down to remove latchup.

ESD protection can be tested in various ways; the transmitter outputs and receiver inputs of this product family are characterized for protection to the following limits:

- 1) ±15kV using the Human Body Model
- 2) ±8kV using the Contact Discharge method specified in IEC 1000-4-2
- 3) ±15kV using IEC 1000-4-2's Air-Gap Discharge method

### ESD Test Conditions

ESD performance depends on a variety of conditions. Contact Maxim for a reliability report that documents test setup, test methodology, and test results.

### Human Body Model

Figure 5a shows the Human Body Model and Figure 5b shows the current waveform it generates when discharged into a low impedance. This model consists of a 100pF capacitor charged to the ESD voltage of interest, which is then discharged into the test device through a 1.5kΩ resistor.

### IEC 1000-4-2

The IEC 1000-4-2 standard covers ESD testing and performance of finished equipment; it does not specifically refer to integrated circuits. The MAX3233E/MAX3235E help you design equipment that meets Level 4 (the highest level) of IEC 1000-4-2, without the need for additional ESD-protection components.

The major difference between tests done using the Human Body Model and IEC 1000-4-2 is higher peak current in IEC 1000-4-2, because series resistance is lower in the IEC 1000-4-2 model. Hence, the ESD withstand voltage measured to IEC 1000-4-2 is generally lower than

# ±15kV ESD-Protected, 1µA, 250kbps, 3.3V/5V, Dual RS-232 Transceivers with Internal Capacitors

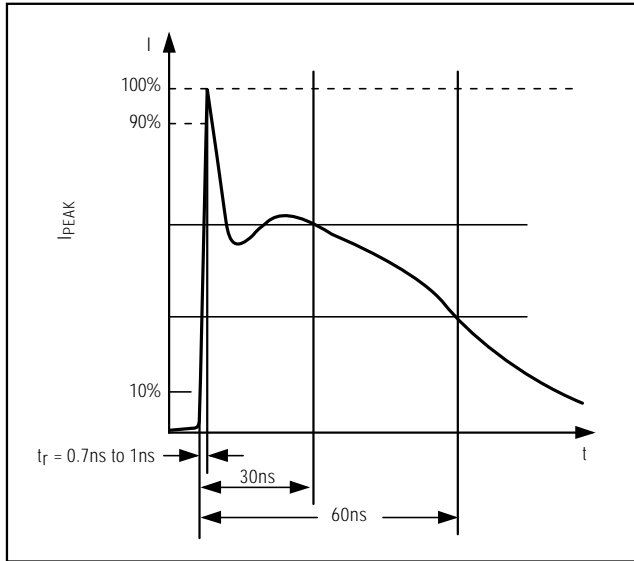

Figure 6b. IEC 1000-4-2 ESD Generator Current Waveform

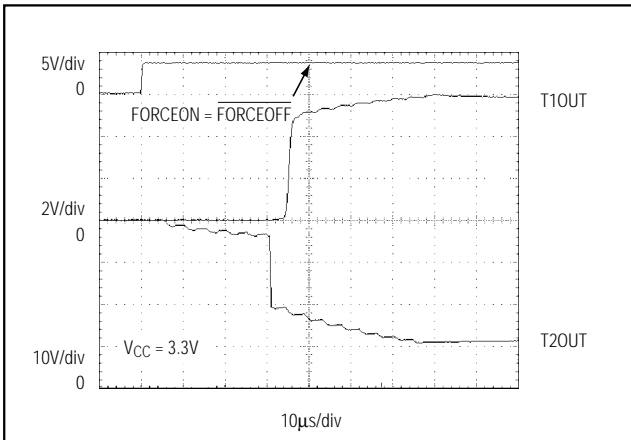

Figure 7. Transmitter Outputs when Exiting Shutdown or Powering Up

that measured using the Human Body Model. Figure 6a shows the IEC 1000-4-2 model, and Figure 6b shows the current waveform for the ±8kV, IEC 1000-4-2, Level 4, ESD contact-discharge test.

The air-gap test involves approaching the device with a charged probe. The contact-discharge method connects the probe to the device before the probe is energized.

### Machine Model

The Machine Model for ESD tests all pins using a 200pF storage capacitor and zero discharge resistance. Its objective is to emulate the stress caused by contact that occurs with handling and assembly during

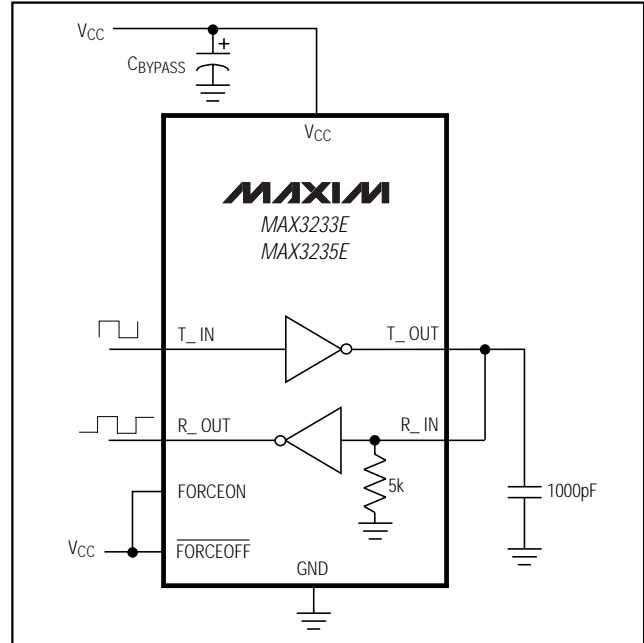

Figure 8. Loopback Test Circuit

manufacturing. Of course, all pins require this protection during manufacturing, not just RS-232 inputs and outputs. Therefore, after PC board assembly, the Machine Model is less relevant to I/O ports.

## Applications Information

### Charge Pumps

The MAX3233E/MAX3235E do not require external capacitors to operate their internal charge pumps.

The MAX3235E can be operated down to 3.0V by paralleling the internal C1 capacitor with an external 0.1µF. When using an external capacitor across the C1 terminals, check to confirm that the total supply voltage measured from V+ to V- does not exceed the absolute maximum voltage of 13V. With the external 0.1µF capacitor added, the MAX3235E should not be used with a supply greater than +3.9V.

### Power-Supply Decoupling

In most applications, a 0.1µF VCC bypass capacitor is adequate. Connect bypass capacitors as close to the IC as possible.

### Transmitter Outputs when Exiting Shutdown

Figure 7 shows two transmitter outputs when exiting shutdown mode. As they become active, the two transmitter outputs are shown going to opposite RS-232 levels (one transmitter input is high, the other is low).

# ±15kV ESD-Protected, 1µA, 250kbps, 3.3V/5V, Dual RS-232 Transceivers with Internal Capacitors

Each transmitter is loaded with 3kΩ in parallel with 1000pF. The transmitter outputs display no ringing or undesirable transients as they come out of shutdown. Note that the transmitters are enabled only when the magnitude of V- exceeds approximately -3V.

### High Data Rates

The MAX3233E/MAX3235E maintain the RS-232 ±5.0V minimum transmitter output voltage even at high data rates. Figure 8 shows a transmitter loopback test circuit. Figure 9 shows a loopback test result at 120kbps, and Figure 10 shows the same test at 250kbps. For

Figure 9, all transmitters were driven simultaneously at 120kbps into RS-232 loads in parallel with 1000pF. For Figure 10, a single transmitter was driven at 250kbps, and all transmitters were loaded with an RS-232 receiver in parallel with 250pF.

### Interconnection with 3V and 5V Logic

The MAX3233E/MAX3235E can directly interface with various 5V logic families, including ACT and HCT CMOS. See Table 3 for more information on possible combinations of interconnections.

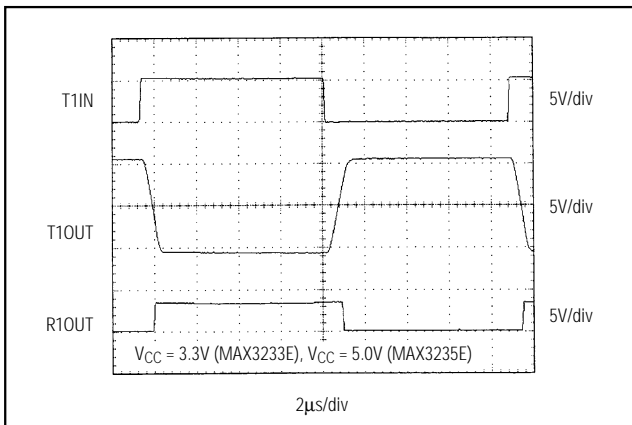

Figure 9. Loopback Test Result at 120kbps

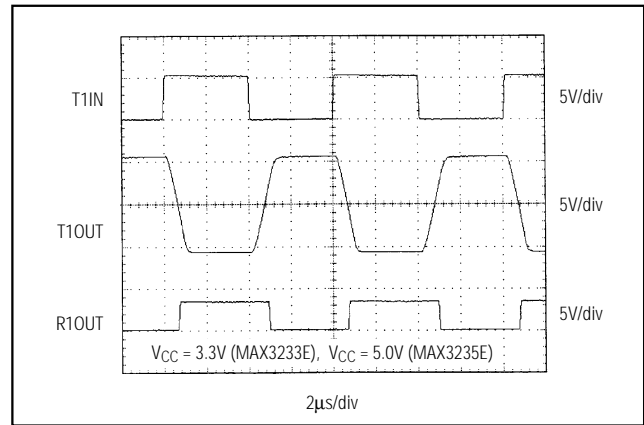

Figure 10. Loopback Test Result at 250kbps

**Table 3. Logic Family Compatibility with Various Supply Voltages**

DEVICE	LOGIC POWER-SUPPLY VOLTAGE (V)	V <sub>CC</sub> SUPPLY VOLTAGE (V)	COMPATIBILITY
MAX3233E	3.3	3.3	Compatible with all CMOS families
MAX3233E	5	3.3	Compatible with ACT and HCT CMOS, and with AC, HC, or CD4000 CMOS
MAX3235E	3.3/5	5	Compatible with all TTL and CMOS families

# ±15kV ESD-Protected, 1µA, 250kbps, 3.3V/5V, Dual RS-232 Transceivers with Internal Capacitors

Typical Operating Circuit

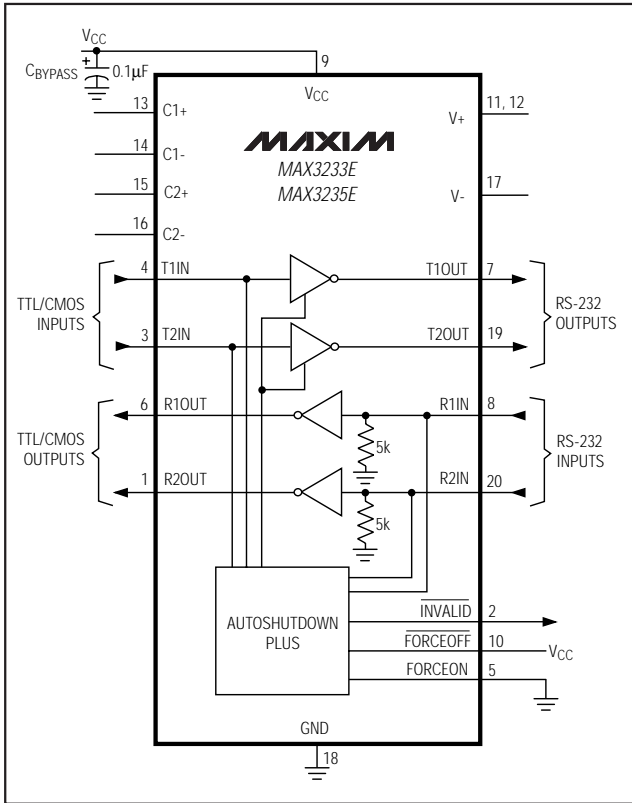

Ordering Information (continued)

PART	TEMP. RANGE	PIN-PACKAGE
MAX3235ECWP	0°C to +70°C	20 SO
MAX3235ECPD	0°C to +70°C	20 Plastic DIP
MAX3235EEWP	-40°C to +85°C	20 SO
MAX3235EEPD	-40°C to +85°C	20 Plastic DIP

## Chip Information

TRANSISTOR COUNT: 1129

Maxim cannot assume responsibility for use of any circuitry other than circuitry entirely embodied in a Maxim product. No circuit patent licenses are implied. Maxim reserves the right to change the circuitry and specifications without notice at any time.

12 Maxim Integrated Products, 120 San Gabriel Drive, Sunnyvale, CA 94086 408-737-7600

© 1999 Maxim Integrated Products

Printed USA

MAXIM is a registered trademark of Maxim Integrated Products.