



M29W320DT M29W320DB

32 Mbit (4Mbx8 or 2Mbx16, Non-uniform Parameter Blocks, Boot Block), 3V Supply Flash memory

Feature summary

- Supply Voltage
 - $V_{CC} = 2.7V$ to $3.6V$ for Program, Erase and Read
 - $V_{PP} = 12V$ for Fast Program (optional)
- Access time: 70, 90ns
- Programming time
 - $10\mu s$ per Byte/Word typical
- 67 memory blocks
 - 1 Boot Block (Top or Bottom Location)
 - 2 Parameter and 64 Main Blocks
- Program/Erase controller
 - Embedded Byte/Word Program algorithms
- Erase Suspend and Resume modes
 - Read and Program another Block during Erase Suspend
- Unlock Bypass Program command
 - Faster Production/Batch Programming
- V_{PP}/\overline{WP} pin for Fast Program and Write Protect
- Temporary Block Unprotection mode
- Common Flash Interface
 - 64 bit Security code
- Low power consumption
 - Standby and Automatic Standby
- 100,000 Program/Erase cycles per block
- Electronic Signature
 - Manufacturer Code: 0020h
 - Top Device Code M29W320DT: 22CAh
 - Bottom Device Code M29W320DB: 22CBh
- ECOPACK[®] packages available

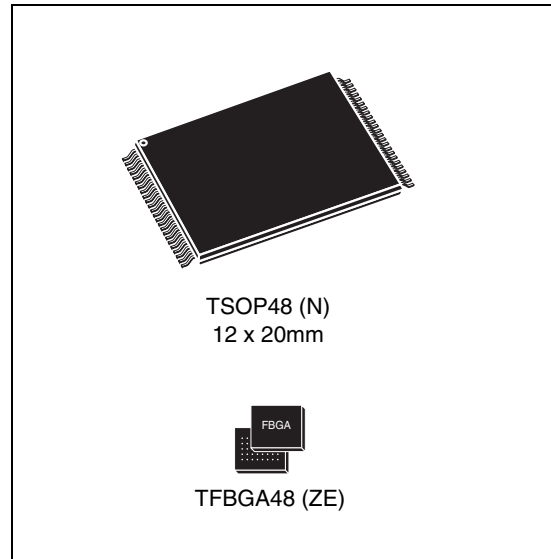

Contents

1	Summary description	6
2	Signal descriptions	12
2.1	Address Inputs (A0-A20)	12
2.2	Data Inputs/Outputs (DQ0-DQ7)	12
2.3	Data Inputs/Outputs (DQ8-DQ14)	12
2.4	Data Input/Output or Address Input (DQ15A-1)	12
2.5	Chip Enable (E)	12
2.6	Output Enable (G)	12
2.7	Write Enable (W)	13
2.8	V _{PP} /Write Protect (V _{PP} /WP)	13
2.9	Reset/Block Temporary Unprotect (\overline{RP})	13
2.10	Ready/Busy Output (RB)	14
2.11	Byte/Word Organization Select (BYTE)	14
2.12	V _{CC} Supply Voltage	14
2.13	V _{SS} Ground	14
3	Bus operations	15
3.1	Bus Read	15
3.2	Bus Write	15
3.3	Output Disable	15
3.4	Standby	15
3.5	Automatic Standby	15
3.6	Special bus operations	16
3.6.1	Electronic Signature	16
3.6.2	Block Protect and Chip Unprotect	16
4	Command Interface	17
4.1	Read/Reset command	17
4.2	Auto Select command	17
4.3	Read CFI Query command	18
4.4	Program command	18

4.5	Unlock Bypass command	18
4.6	Unlock Bypass Program command	19
4.7	Unlock Bypass Reset command	19
4.8	Chip Erase command	19
4.9	Block Erase command	20
4.10	Erase Suspend command	20
4.11	Erase Resume command	21
4.12	Block Protect and Chip Unprotect commands	21
5	Status Register	25
5.1	Data Polling Bit (DQ7)	25
5.2	Toggle Bit (DQ6)	25
5.3	Error Bit (DQ5)	26
5.4	Erase Timer Bit (DQ3)	26
5.5	Alternative Toggle Bit (DQ2)	26
6	Maximum rating	29
7	DC and AC parameters	30
8	Package mechanical	37
9	Part numbering	39
Appendix A Block Addresses		40
Appendix B Common Flash Interface (CFI)		44
Appendix C Block Protection		48
C.1	Programmer Technique	48
C.2	In-System Technique	48
10	Revision history	54

List of tables

Table 1.	Signal Names	7
Table 2.	Bus Operations, BYTE = V_{IL}	16
Table 3.	Bus Operations, BYTE = V_{IH}	16
Table 4.	Commands, 16-bit mode, BYTE = V_{IH}	22
Table 5.	Commands, 8-bit mode, BYTE = V_{IL}	23
Table 6.	Program, Erase Times and Program, Erase Endurance Cycles.	24
Table 7.	Status Register Bits	27
Table 8.	Absolute Maximum Ratings	29
Table 9.	Operating and AC Measurement Conditions	30
Table 10.	Device Capacitance	31
Table 11.	DC Characteristics	32
Table 12.	Read AC Characteristics	33
Table 13.	Write AC Characteristics, Write Enable Controlled.	34
Table 14.	Write AC Characteristics, Chip Enable Controlled	35
Table 15.	Reset/Block Temporary Unprotect AC Characteristics.	36
Table 16.	TSOP48 Lead Plastic Thin Small Outline, 12x20 mm, Package Mechanical Data.	37
Table 17.	TFBGA48 6x8mm - 6x8 Ball Array, 0.8mm Pitch, Package Mechanical Data	38
Table 18.	Ordering Information Scheme.	39
Table 19.	Top Boot Block Addresses, M29W320DT	40
Table 20.	Bottom Boot Block Addresses, M29W320DB	42
Table 21.	Query Structure Overview	44
Table 22.	CFI Query Identification String	44
Table 23.	CFI Query System Interface Information	45
Table 24.	Device Geometry Definition	45
Table 25.	Primary Algorithm-Specific Extended Query Table.	46
Table 26.	Security Code Area.	47
Table 27.	Programmer Technique Bus Operations, BYTE = V_{IH} or V_{IL}	49
Table 28.	Document revision history	54

List of figures

Figure 1.	Logic Diagram.	7
Figure 2.	TSOP Connections.	8
Figure 3.	TFBGA48 Connections (Top view through package).	9
Figure 4.	Block Addresses (x8)	10
Figure 5.	Block Addresses (x16)	11
Figure 6.	Data Polling Flowchart	27
Figure 7.	Data Toggle Flowchart	28
Figure 8.	AC Measurement I/O Waveform.	30
Figure 9.	Read Mode AC Waveforms	33
Figure 10.	Write AC Waveforms, Write Enable Controlled	34
Figure 11.	Write AC Waveforms, Chip Enable Controlled	35
Figure 12.	Reset/Block Temporary Unprotect AC Waveforms.	36
Figure 13.	Accelerated Program Timing Waveforms.	36
Figure 14.	TSOP48 Lead Plastic Thin Small Outline, 12x20 Mm, Top View Package Outline	37
Figure 15.	TFBGA48 6x8mm - 6x8 Ball Array, 0.8mm Pitch, Bottom View Package Outline	38
Figure 16.	Programmer Equipment Block Protect Flowchart.	50
Figure 17.	Programmer Equipment Chip Unprotect Flowchart	51
Figure 18.	In-System Equipment Block Protect Flowchart.	52
Figure 19.	In-System Equipment Chip Unprotect Flowchart	53

1 Summary description

The M29W320D is a 32 Mbit (4Mb x8 or 2Mb x16) non-volatile memory that can be read, erased and reprogrammed. These operations can be performed using a single low voltage (2.7 to 3.6V) supply. On power-up the memory defaults to its Read mode where it can be read in the same way as a ROM or EPROM.

The memory is divided into blocks that can be erased independently so it is possible to preserve valid data while old data is erased. Each block can be protected independently to prevent accidental Program or Erase commands from modifying the memory. Program and Erase commands are written to the Command Interface of the memory. An on-chip Program/Erase Controller simplifies the process of programming or erasing the memory by taking care of all of the special operations that are required to update the memory contents. The end of a program or erase operation can be detected and any error conditions identified. The command set required to control the memory is consistent with JEDEC standards.

The blocks in the memory are asymmetrically arranged, see [Figure 4](#) and [Figure 5](#), [Table 19](#) and [Table 20](#). The first or last 64 Kbytes have been divided into four additional blocks. The 16 Kbyte Boot Block can be used for small initialization code to start the microprocessor, the two 8 Kbyte Parameter Blocks can be used for parameter storage and the remaining 32 Kbyte is a small Main Block where the application may be stored.

Chip Enable, Output Enable and Write Enable signals control the bus operation of the memory. They allow simple connection to most microprocessors, often without additional logic.

The memory is offered in TSOP48 (12 x 20mm), and TFBGA48 (6x8mm, 0.8mm pitch) packages. In order to meet environmental requirements, ST offers the M29W320D in ECOPACK[®] packages. ECOPACK packages are Lead-free. The category of second Level Interconnect is marked on the package and on the inner box label, in compliance with JEDEC Standard JESD97. The maximum ratings related to soldering conditions are also marked on the inner box label. ECOPACK is an ST trademark. ECOPACK specifications are available at: www.st.com.

The memory is supplied with all the bits erased (set to 1).

Figure 1. Logic Diagram

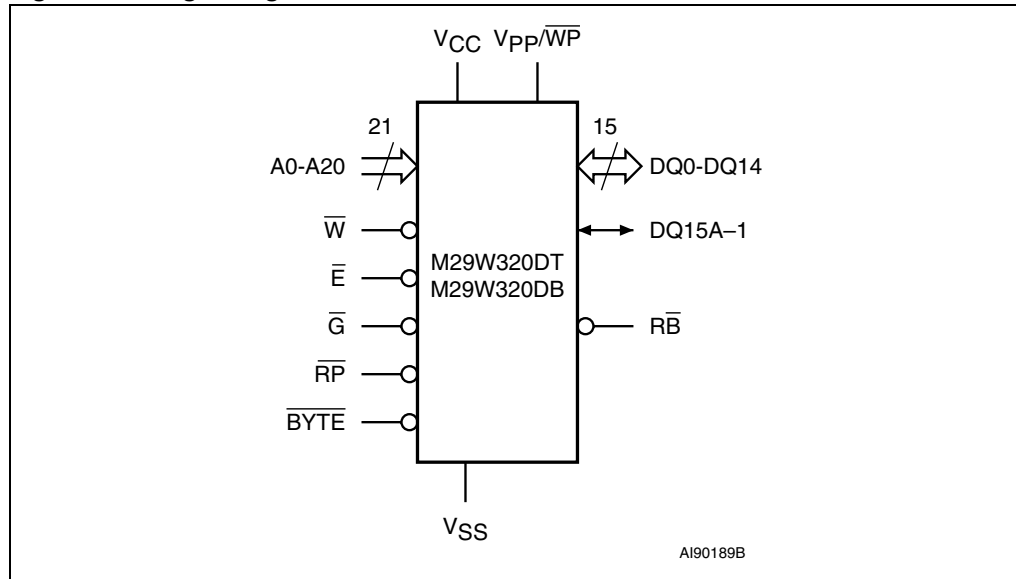

Table 1. Signal Names

A0-A20	Address Inputs
DQ0-DQ7	Data Inputs/Outputs
DQ8-DQ14	Data Inputs/Outputs
DQ15A-1	Data Input/Output or Address Input
\bar{E}	Chip Enable
\bar{G}	Output Enable
\bar{W}	Write Enable
\bar{RP}	Reset/Block Temporary Unprotect
\bar{RB}	Ready/Busy Output
\bar{BYTE}	Byte/Word Organization Select
V_{CC}	Supply Voltage
V_{PP}/\bar{WP}	V_{PP} /Write Protect
V_{SS}	Ground
NC	Not Connected Internally

Figure 2. TSOP Connections

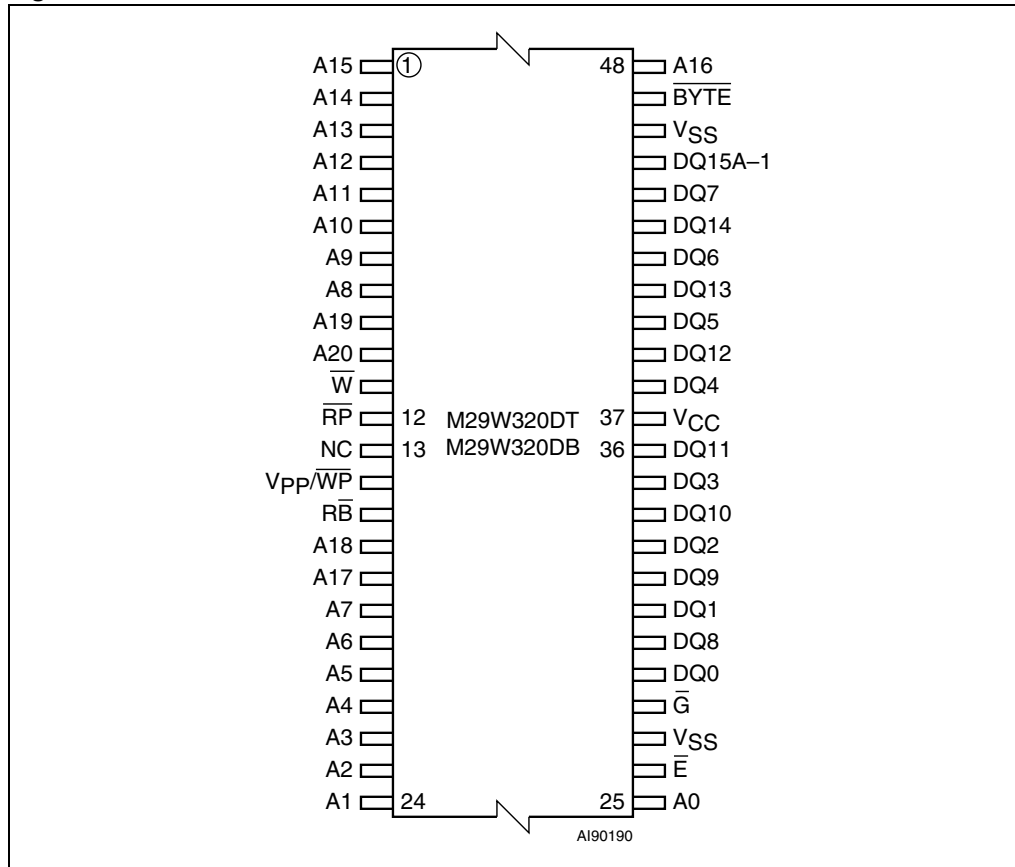

Figure 3. TFBGA48 Connections (Top view through package)

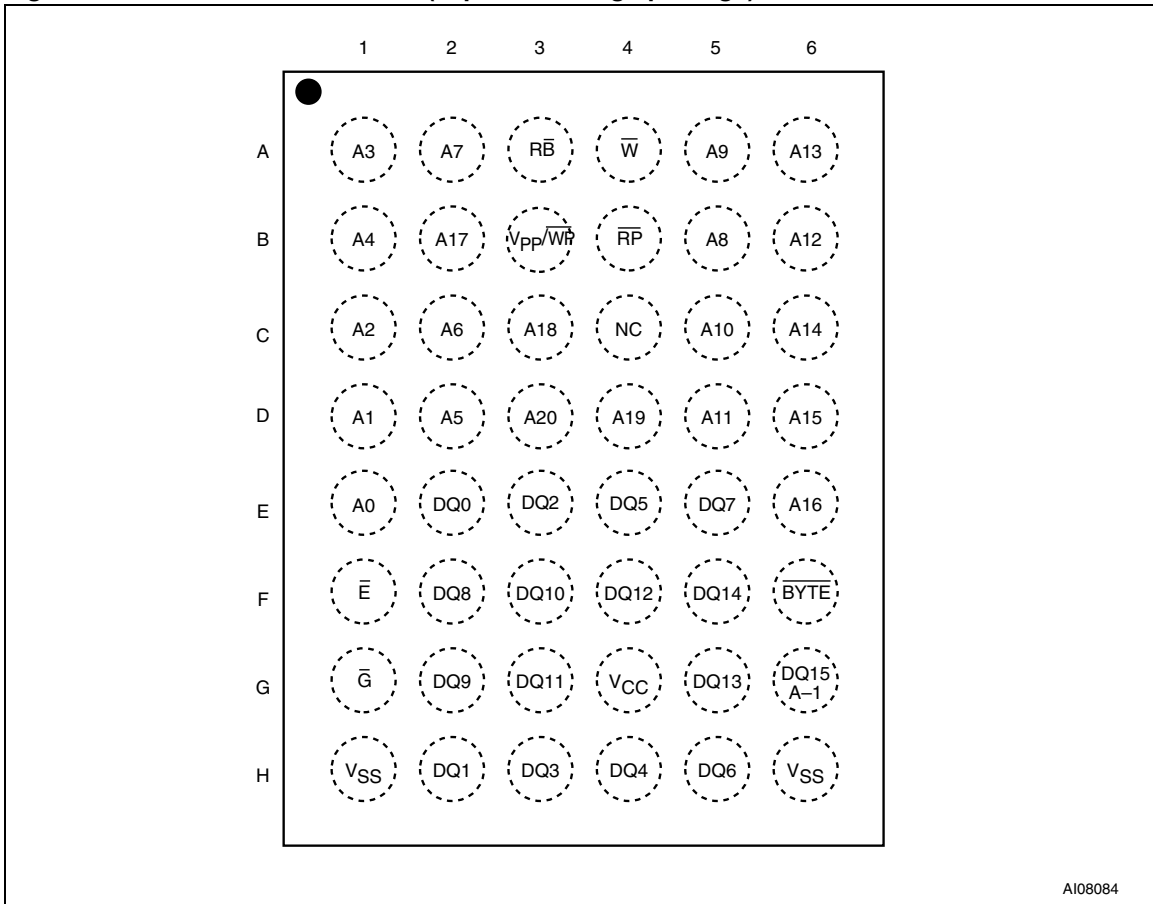
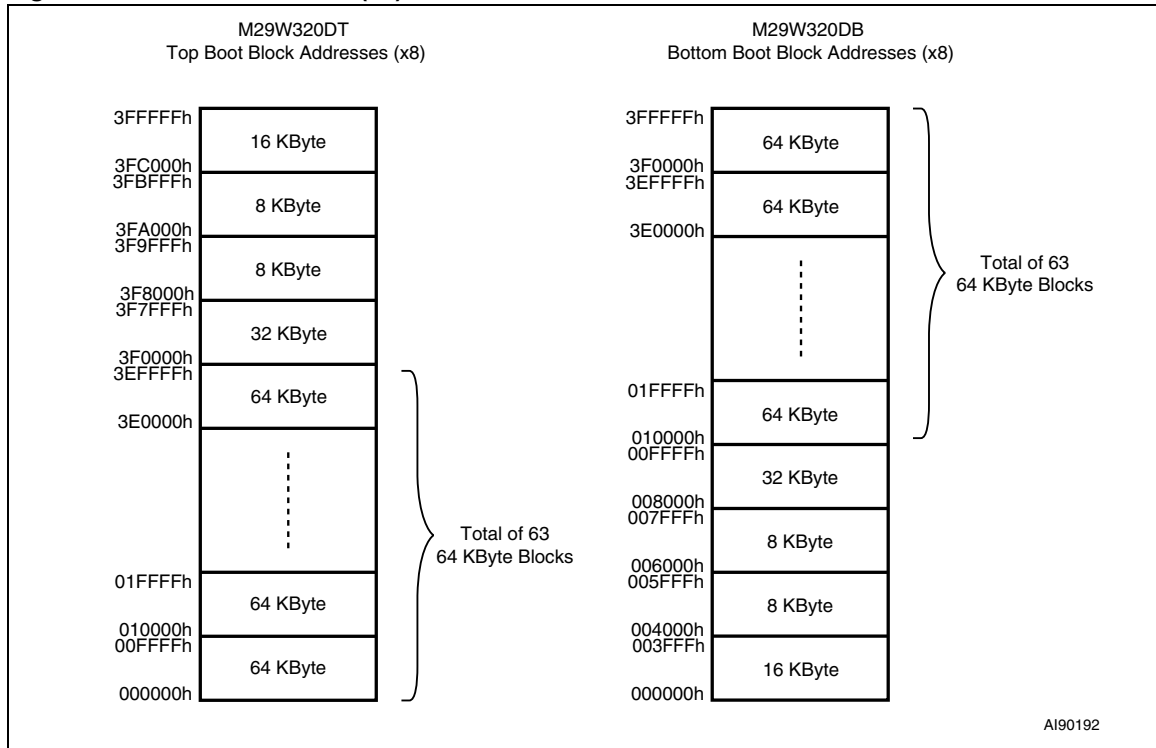
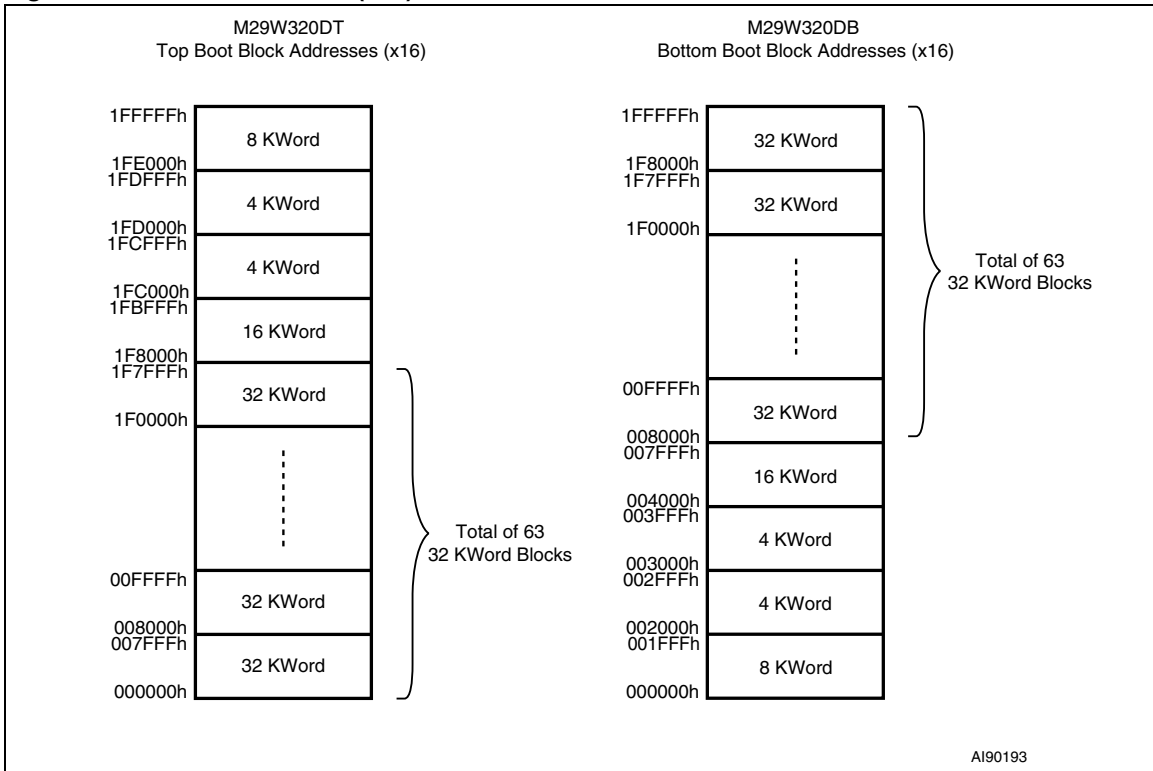

Figure 4. Block Addresses (x8)



1. Also see [Appendix A: Block Addresses, Table 19](#) and [Table 20](#) for a full listing of the Block Addresses.

Figure 5. Block Addresses (x16)



AI90193

1. Also see Appendix [Appendix A: Block Addresses](#), [Table 19](#) and [Table 20](#) for a full listing of the Block Addresses.

2 Signal descriptions

See [Figure 1: Logic Diagram](#), and [Table 1: Signal Names](#), for a brief overview of the signals connected to this device.

2.1 Address Inputs (A0-A20)

The Address Inputs select the cells in the memory array to access during Bus Read operations. During Bus Write operations they control the commands sent to the Command Interface of the internal state machine.

2.2 Data Inputs/Outputs (DQ0-DQ7)

The Data I/O outputs the data stored at the selected address during a Bus Read operation. During Bus Write operations they represent the commands sent to the Command Interface of the internal state machine.

2.3 Data Inputs/Outputs (DQ8-DQ14)

The Data I/O outputs the data stored at the selected address during a Bus Read operation when $\overline{\text{BYTE}}$ is High, V_{IH} . When $\overline{\text{BYTE}}$ is Low, V_{IL} , these pins are not used and are high impedance. During Bus Write operations the Command Register does not use these bits. When reading the Status Register these bits should be ignored.

2.4 Data Input/Output or Address Input (DQ15A-1)

When $\overline{\text{BYTE}}$ is High, V_{IH} , this pin behaves as a Data Input/Output pin (as DQ8-DQ14). When $\overline{\text{BYTE}}$ is Low, V_{IL} , this pin behaves as an address pin; DQ15A-1 Low will select the LSB of the Word on the other addresses, DQ15A-1 High will select the MSB. Throughout the text consider references to the Data Input/Output to include this pin when $\overline{\text{BYTE}}$ is High and references to the Address Inputs to include this pin when $\overline{\text{BYTE}}$ is Low except when stated explicitly otherwise.

2.5 Chip Enable ($\overline{\text{E}}$)

The Chip Enable, $\overline{\text{E}}$, activates the memory, allowing Bus Read and Bus Write operations to be performed. When Chip Enable is High, V_{IH} , all other pins are ignored.

2.6 Output Enable ($\overline{\text{G}}$)

The Output Enable, $\overline{\text{G}}$, controls the Bus Read operation of the memory.

2.7 Write Enable (\overline{W})

The Write Enable, \overline{W} , controls the Bus Write operation of the memory's Command Interface.

2.8 V_{PP} /Write Protect (V_{PP}/\overline{WP})

The V_{PP} /Write Protect pin provides two functions. The V_{PP} function allows the memory to use an external high voltage power supply to reduce the time required for Unlock Bypass Program operations. The Write Protect function provides a hardware method of protecting the 16 Kbyte Boot Block. The V_{PP} /Write Protect pin must not be left floating or unconnected.

When V_{PP} /Write Protect is Low, V_{IL} , the memory protects the 16 Kbyte Boot Block; Program and Erase operations in this block are ignored while V_{PP} /Write Protect is Low.

When V_{PP} /Write Protect is High, V_{IH} , the memory reverts to the previous protection status of the 16 Kbyte boot block. Program and Erase operations can now modify the data in the 16 Kbyte Boot Block unless the block is protected using Block Protection.

When V_{PP} /Write Protect is raised to V_{PP} the memory automatically enters the Unlock Bypass mode. When V_{PP} /Write Protect returns to V_{IH} or V_{IL} normal operation resumes. During Unlock Bypass Program operations the memory draws I_{PP} from the pin to supply the programming circuits. See the description of the Unlock Bypass command in the Command Interface section. The transitions from V_{IH} to V_{PP} and from V_{PP} to V_{IH} must be slower than t_{VHVPP} see [Figure 13](#).

Never raise V_{PP} /Write Protect to V_{PP} from any mode except Read mode, otherwise the memory may be left in an indeterminate state.

A 0.1 μ F capacitor should be connected between the V_{PP} /Write Protect pin and the V_{SS} Ground pin to decouple the current surges from the power supply. The PCB track widths must be sufficient to carry the currents required during Unlock Bypass Program, I_{PP} .

2.9 Reset/Block Temporary Unprotect (\overline{RP})

The Reset/Block Temporary Unprotect pin can be used to apply a Hardware Reset to the memory or to temporarily unprotect all Blocks that have been protected.

Note that if V_{PP}/\overline{WP} is at V_{IL} , then the 16 KByte outermost boot block will remain protect even if \overline{RP} is at V_{ID} .

A Hardware Reset is achieved by holding Reset/Block Temporary Unprotect Low, V_{IL} , for at least t_{PLPX} . After Reset/Block Temporary Unprotect goes High, V_{IH} , the memory will be ready for Bus Read and Bus Write operations after t_{PHEL} or t_{RHEL} , whichever occurs last. See the Ready/Busy Output section, [Table 15](#) and [Figure 12](#), for more details.

Holding \overline{RP} at V_{ID} will temporarily unprotect the protected Blocks in the memory. Program and Erase operations on all blocks will be possible. The transition from V_{IH} to V_{ID} must be slower than t_{PHPHH} .

2.10 Ready/Busy Output (\overline{RB})

The Ready/Busy pin is an open-drain output that can be used to identify when the device is performing a Program or Erase operation. During Program or Erase operations Ready/Busy is Low, V_{OL} . Ready/Busy is high-impedance during Read mode, Auto Select mode and Erase Suspend mode.

Note that if V_{PP}/\overline{WP} is at V_{IL} , then the 16 KByte outermost boot block will remain protect even if RP is at V_{ID} .

After a Hardware Reset, Bus Read and Bus Write operations cannot begin until Ready/Busy becomes high-impedance. See [Table 15](#) and [Figure 12](#).

The use of an open-drain output allows the Ready/Busy pins from several memories to be connected to a single pull-up resistor. A Low will then indicate that one, or more, of the memories is busy.

2.11 Byte/Word Organization Select (\overline{BYTE})

The Byte/Word Organization Select pin is used to switch between the x8 and x16 Bus modes of the memory. When Byte/Word Organization Select is Low, V_{IL} , the memory is in x8 mode, when it is High, V_{IH} , the memory is in x16 mode.

2.12 V_{CC} Supply Voltage

V_{CC} provides the power supply for all operations (Read, Program and Erase).

The Command Interface is disabled when the V_{CC} Supply Voltage is less than the Lockout Voltage, V_{LKO} . This prevents Bus Write operations from accidentally damaging the data during power up, power down and power surges. If the Program/Erase Controller is programming or erasing during this time then the operation aborts and the memory contents being altered will be invalid.

A 0.1 μ F capacitor should be connected between the V_{CC} Supply Voltage pin and the V_{SS} Ground pin to decouple the current surges from the power supply. The PCB track widths must be sufficient to carry the currents required during Program and Erase operations, I_{CC3} .

2.13 V_{SS} Ground

V_{SS} is the reference for all voltage measurements.

3 Bus operations

There are five standard bus operations that control the device. These are Bus Read, Bus Write, Output Disable, Standby and Automatic Standby. See [Table 2](#) and [Table 3](#), Bus operations, for a summary. Typically glitches of less than 5ns on Chip Enable or Write Enable are ignored by the memory and do not affect bus operations.

3.1 Bus Read

Bus Read operations read from the memory cells, or specific registers in the Command Interface. A valid Bus Read operation involves setting the desired address on the Address Inputs, applying a Low signal, V_{IL} , to Chip Enable and Output Enable and keeping Write Enable High, V_{IH} . The Data Inputs/Outputs will output the value, see [Figure 9: Read Mode AC Waveforms](#), and [Table 12: Read AC Characteristics](#), for details of when the output becomes valid.

3.2 Bus Write

Bus Write operations write to the Command Interface. A valid Bus Write operation begins by setting the desired address on the Address Inputs. The Address Inputs are latched by the Command Interface on the falling edge of Chip Enable or Write Enable, whichever occurs last. The Data Inputs/Outputs are latched by the Command Interface on the rising edge of Chip Enable or Write Enable, whichever occurs first. Output Enable must remain High, V_{IH} , during the whole Bus Write operation. See [Figure 10](#) and [Figure 11](#), Write AC waveforms, and [Table 13](#) and [Table 14](#), Write AC Characteristics, for details of the timing requirements.

3.3 Output Disable

The Data Inputs/Outputs are in the high impedance state when Output Enable is High, V_{IH} .

3.4 Standby

When Chip Enable is High, V_{IH} , the memory enters Standby mode and the Data Inputs/Outputs pins are placed in the high-impedance state. To reduce the Supply Current to the Standby Supply Current, I_{CC2} , Chip Enable should be held within $V_{CC} \pm 0.2V$. For the Standby current level see [Table 11: DC Characteristics](#).

During program or erase operations the memory will continue to use the Program/Erase Supply Current, I_{CC3} , for Program or Erase operations until the operation completes.

3.5 Automatic Standby

If CMOS levels ($V_{CC} \pm 0.2V$) are used to drive the bus and the bus is inactive for 300ns or more the memory enters Automatic Standby where the internal Supply Current is reduced to the Standby Supply Current, I_{CC2} . The Data Inputs/Outputs will still output data if a Bus Read operation is in progress.

3.6 Special bus operations

Additional bus operations can be performed to read the Electronic Signature and also to apply and remove Block Protection. These bus operations are intended for use by programming equipment and are not usually used in applications. They require V_{ID} to be applied to some pins.

3.6.1 Electronic Signature

The memory has two codes, the manufacturer code and the device code, that can be read to identify the memory. These codes can be read by applying the signals listed in [Table 2](#) and [Table 3](#), Bus Operations.

3.6.2 Block Protect and Chip Unprotect

Each block can be separately protected against accidental Program or Erase. The whole chip can be unprotected to allow the data inside the blocks to be changed.

Block Protect and Chip Unprotect operations are described in [Appendix C: Block Protection](#).

Table 2. Bus Operations, $\overline{\text{BYTE}} = V_{IL}$ ⁽¹⁾

Operation	$\overline{\text{E}}$	$\overline{\text{G}}$	$\overline{\text{W}}$	Address Inputs DQ15A-1, A0-A20	Data Inputs/Outputs	
					DQ14-DQ8	DQ7-DQ0
Bus Read	V_{IL}	V_{IL}	V_{IH}	Cell Address	Hi-Z	Data Output
Bus Write	V_{IL}	V_{IH}	V_{IL}	Command Address	Hi-Z	Data Input
Output Disable	X	V_{IH}	V_{IH}	X	Hi-Z	Hi-Z
Standby	V_{IH}	X	X	X	Hi-Z	Hi-Z
Read Manufacturer Code	V_{IL}	V_{IL}	V_{IH}	A0 = V_{IL} , A1 = V_{IL} , A9 = V_{ID} , Others V_{IL} or V_{IH}	Hi-Z	20h
Read Device Code	V_{IL}	V_{IL}	V_{IH}	A0 = V_{IH} , A1 = V_{IL} , A9 = V_{ID} , Others V_{IL} or V_{IH}	Hi-Z	CAh (M29W320DT) CBh (M29W320DB)

1. X = V_{IL} or V_{IH} .

Table 3. Bus Operations, $\overline{\text{BYTE}} = V_{IH}$ ⁽¹⁾

Operation	$\overline{\text{E}}$	$\overline{\text{G}}$	$\overline{\text{W}}$	Address Inputs A0-A20	Data Inputs/Outputs
					DQ15A-1, DQ14-DQ0
Bus Read	V_{IL}	V_{IL}	V_{IH}	Cell Address	Data Output
Bus Write	V_{IL}	V_{IH}	V_{IL}	Command Address	Data Input
Output Disable	X	V_{IH}	V_{IH}	X	Hi-Z
Standby	V_{IH}	X	X	X	Hi-Z
Read Manufacturer Code	V_{IL}	V_{IL}	V_{IH}	A0 = V_{IL} , A1 = V_{IL} , A9 = V_{ID} , Others V_{IL} or V_{IH}	0020h
Read Device Code	V_{IL}	V_{IL}	V_{IH}	A0 = V_{IH} , A1 = V_{IL} , A9 = V_{ID} , Others V_{IL} or V_{IH}	22CAh (M29W320DT) 22CBh (M29W320DB)

1. X = V_{IL} or V_{IH} .

4 Command Interface

All Bus Write operations to the memory are interpreted by the Command Interface. Commands consist of one or more sequential Bus Write operations. Failure to observe a valid sequence of Bus Write operations will result in the memory returning to Read mode. The long command sequences are imposed to maximize data security.

The address used for the commands changes depending on whether the memory is in 16-bit or 8-bit mode. See either [Table 4](#), or [Table 5](#), depending on the configuration that is being used, for a summary of the commands.

4.1 Read/Reset command

The Read/Reset command returns the memory to its Read mode where it behaves like a ROM or EPROM, unless otherwise stated. It also resets the errors in the Status Register. Either one or three Bus Write operations can be used to issue the Read/Reset command.

The Read/Reset Command can be issued, between Bus Write cycles before the start of a program or erase operation, to return the device to read mode. Once the program or erase operation has started the Read/Reset command is no longer accepted. The Read/Reset command will not abort an Erase operation when issued while in Erase Suspend.

4.2 Auto Select command

The Auto Select command is used to read the Manufacturer Code, the Device Code and the Block Protection Status. Three consecutive Bus Write operations are required to issue the Auto Select command. Once the Auto Select command is issued the memory remains in Auto Select mode until a Read/Reset command is issued. Read CFI Query and Read/Reset commands are accepted in Auto Select mode, all other commands are ignored.

From the Auto Select mode the Manufacturer Code can be read using a Bus Read operation with $A0 = V_{IL}$ and $A1 = V_{IL}$. The other address bits may be set to either V_{IL} or V_{IH} . The Manufacturer Code for STMicroelectronics is 0020h.

The Device Code can be read using a Bus Read operation with $A0 = V_{IH}$ and $A1 = V_{IL}$. The other address bits may be set to either V_{IL} or V_{IH} . The Device Code for the M29W320DT is 22CAh and for the M29W320DB is 22CBh.

The Block Protection Status of each block can be read using a Bus Read operation with $A0 = V_{IL}$, $A1 = V_{IH}$, and A12-A20 specifying the address of the block. The other address bits may be set to either V_{IL} or V_{IH} . If the addressed block is protected then 01h is output on Data Inputs/Outputs DQ0-DQ7, otherwise 00h is output.

4.3 Read CFI Query command

The Read CFI Query Command is used to read data from the Common Flash Interface (CFI) Memory Area. This command is valid when the device is in the Read Array mode, or when the device is in Autoselected mode.

One Bus Write cycle is required to issue the Read CFI Query Command. Once the command is issued subsequent Bus Read operations read from the Common Flash Interface Memory Area.

The Read/Reset command must be issued to return the device to the previous mode (the Read Array mode or Autoselected mode). A second Read/Reset command would be needed if the device is to be put in the Read Array mode from Autoselected mode.

See [Appendix B: Common Flash Interface \(CFI\)](#), [Table 21](#), [Table 22](#), [Table 23](#), [Table 24](#), [Table 25](#) and [Table 26](#) for details on the information contained in the Common Flash Interface (CFI) memory area.

4.4 Program command

The Program command can be used to program a value to one address in the memory array at a time. The command requires four Bus Write operations, the final write operation latches the address and data in the internal state machine and starts the Program/Erase Controller.

If the address falls in a protected block then the Program command is ignored, the data remains unchanged. The Status Register is never read and no error condition is given.

During the program operation the memory will ignore all commands. It is not possible to issue any command to abort or pause the operation. Typical program times are given in [Table 6](#). Bus Read operations during the program operation will output the Status Register on the Data Inputs/Outputs. See the section on the Status Register for more details.

After the program operation has completed the memory will return to the Read mode, unless an error has occurred. When an error occurs the memory will continue to output the Status Register. A Read/Reset command must be issued to reset the error condition and return to Read mode.

Note that the Program command cannot change a bit set at '0' back to '1'. One of the Erase Commands must be used to set all the bits in a block or in the whole memory from '0' to '1'.

4.5 Unlock Bypass command

The Unlock Bypass command is used in conjunction with the Unlock Bypass Program command to program the memory. When the cycle time to the device is long (as with some EPROM programmers) considerable time saving can be made by using these commands. Three Bus Write operations are required to issue the Unlock Bypass command.

Once the Unlock Bypass command has been issued the memory will only accept the Unlock Bypass Program command and the Unlock Bypass Reset command. The memory can be read as if in Read mode.

The memory offers accelerated program operations through the V_{PP} /Write Protect pin. When the system asserts V_{PP} on the V_{PP} /Write Protect pin, the memory automatically enters the Unlock Bypass mode. The system may then write the two-cycle Unlock Bypass

program command sequence. The memory uses the higher voltage on the V_{PP} /Write Protect pin, to accelerate the Unlock Bypass Program operation.

Never raise V_{PP} /Write Protect to V_{PP} from any mode except Read mode, otherwise the memory may be left in an indeterminate state.

4.6 Unlock Bypass Program command

The Unlock Bypass Program command can be used to program one address in the memory array at a time. The command requires two Bus Write operations, the final write operation latches the address and data in the internal state machine and starts the Program/Erase Controller.

The Program operation using the Unlock Bypass Program command behaves identically to the Program operation using the Program command. The operation cannot be aborted, the Status Register is read and protected blocks cannot be programmed. Errors must be reset using the Read/Reset command, which leaves the device in Unlock Bypass Mode. See the Program command for details on the behavior.

4.7 Unlock Bypass Reset command

The Unlock Bypass Reset command can be used to return to Read/Reset mode from Unlock Bypass Mode. Two Bus Write operations are required to issue the Unlock Bypass Reset command. Read/Reset command does not exit from Unlock Bypass Mode.

4.8 Chip Erase command

The Chip Erase command can be used to erase the entire chip. Six Bus Write operations are required to issue the Chip Erase Command and start the Program/Erase Controller.

If any blocks are protected then these are ignored and all the other blocks are erased. If all of the blocks are protected the Chip Erase operation appears to start but will terminate within about 100 μ s, leaving the data unchanged. No error condition is given when protected blocks are ignored.

During the erase operation the memory will ignore all commands, including the Erase Suspend command. It is not possible to issue any command to abort the operation. Typical chip erase times are given in [Table 6](#). All Bus Read operations during the Chip Erase operation will output the Status Register on the Data Inputs/Outputs. See the section on the Status Register for more details.

After the Chip Erase operation has completed the memory will return to the Read Mode, unless an error has occurred. When an error occurs the memory will continue to output the Status Register. A Read/Reset command must be issued to reset the error condition and return to Read Mode.

The Chip Erase Command sets all of the bits in unprotected blocks of the memory to '1'. All previous data is lost.

4.9 Block Erase command

The Block Erase command can be used to erase a list of one or more blocks. Six Bus Write operations are required to select the first block in the list. Each additional block in the list can be selected by repeating the sixth Bus Write operation using the address of the additional block. The Block Erase operation starts the Program/Erase Controller about 50 μ s after the last Bus Write operation. Once the Program/Erase Controller starts it is not possible to select any more blocks. Each additional block must therefore be selected within 50 μ s of the last block. The 50 μ s timer restarts when an additional block is selected. The Status Register can be read after the sixth Bus Write operation. See the Status Register section for details on how to identify if the Program/Erase Controller has started the Block Erase operation.

If any selected blocks are protected then these are ignored and all the other selected blocks are erased. If all of the selected blocks are protected the Block Erase operation appears to start but will terminate within about 100 μ s, leaving the data unchanged. No error condition is given when protected blocks are ignored.

During the Block Erase operation the memory will ignore all commands except the Erase Suspend command. Typical block erase times are given in [Table 6](#). All Bus Read operations during the Block Erase operation will output the Status Register on the Data Inputs/Outputs. See the section on the Status Register for more details.

After the Block Erase operation has completed the memory will return to the Read Mode, unless an error has occurred. When an error occurs the memory will continue to output the Status Register. A Read/Reset command must be issued to reset the error condition and return to Read mode.

The Block Erase Command sets all of the bits in the unprotected selected blocks to '1'. All previous data in the selected blocks is lost.

4.10 Erase Suspend command

The Erase Suspend Command may be used to temporarily suspend a Block Erase operation and return the memory to Read mode. The command requires one Bus Write operation.

The Program/Erase Controller will suspend within the Erase Suspend Latency Time (refer to [Table 6](#) for value) of the Erase Suspend Command being issued. Once the Program/Erase Controller has stopped the memory will be set to Read mode and the Erase will be suspended. If the Erase Suspend command is issued during the period when the memory is waiting for an additional block (before the Program/Erase Controller starts) then the Erase is suspended immediately and will start immediately when the Erase Resume Command is issued. It is not possible to select any further blocks to erase after the Erase Resume.

During Erase Suspend it is possible to Read and Program cells in blocks that are not being erased; both Read and Program operations behave as normal on these blocks. If any attempt is made to program in a protected block or in the suspended block then the Program command is ignored and the data remains unchanged. The Status Register is not read and no error condition is given. Reading from blocks that are being erased will output the Status Register.

It is also possible to issue the Auto Select, Read CFI Query and Unlock Bypass commands during an Erase Suspend. The Read/Reset command must be issued to return the device to Read Array mode before the Resume command will be accepted.

4.11 Erase Resume command

The Erase Resume command must be used to restart the Program/Erase Controller after an Erase Suspend. The device must be in Read Array mode before the Resume command will be accepted. An erase can be suspended and resumed more than once.

4.12 Block Protect and Chip Unprotect commands

Each block can be separately protected against accidental Program or Erase. The whole chip can be unprotected to allow the data inside the blocks to be changed.

Block Protect and Chip Unprotect operations are described in [Appendix C: Block Protection](#).

Table 4. Commands, 16-bit mode, $\overline{\text{BYTE}} = V_{\text{IH}}^{(1)(2)}$

Command	Length	Bus Write Operations											
		1st		2nd		3rd		4th		5th		6th	
		Addr	Data	Addr	Data	Addr	Data	Addr	Data	Addr	Data	Addr	Data
Read/Reset ⁽³⁾	1	X	F0										
	3	555	AA	2AA	55	X	F0						
Auto Select ⁽⁴⁾	3	555	AA	2AA	55	555	90						
Program ⁽⁵⁾	4	555	AA	2AA	55	555	A0	PA	PD				
Unlock Bypass ⁽⁶⁾	3	555	AA	2AA	55	555	20						
Unlock Bypass Program ⁽⁵⁾	2	X	A0	PA	PD								
Unlock Bypass Reset ⁽⁷⁾	2	X	90	X	00								
Chip Erase ⁽⁵⁾	6	555	AA	2AA	55	555	80	555	AA	2AA	55	555	10
Block Erase ⁽⁵⁾	6+	555	AA	2AA	55	555	80	555	AA	2AA	55	BA	30
Erase Suspend ⁽⁸⁾	1	X	B0										
Erase Resume ⁽⁹⁾	1	X	30										
Read CFI Query ⁽¹⁰⁾	1	55	98										

1. X Don't Care, PA Program Address, PD Program Data, BA Any address in the Block. All values in the table are in hexadecimal.
2. The Command Interface only uses A-1, A0-A10 and DQ0-DQ7 to verify the commands; A11-A20, DQ8-DQ14 and DQ15 are Don't Care. DQ15A-1 is A-1 when $\overline{\text{BYTE}}$ is V_{IL} or DQ15 when $\overline{\text{BYTE}}$ is V_{IH} .
3. After a Read/Reset command, read the memory as normal until another command is issued. Read/Reset command is ignored during algorithm execution.
4. After an Auto Select command, read Manufacturer ID, Device ID or Block Protection Status.
5. After Program, Unlock Bypass Program, Chip Erase, Block Erase commands read the Status Register until the Program/Erase Controller completes and the memory returns to Read Mode. Add additional Blocks during Block Erase Command with additional Bus Write Operations until Timeout Bit is set.
6. After the Unlock Bypass command issue Unlock Bypass Program or Unlock Bypass Reset commands.
7. After the Unlock Bypass Reset command read the memory as normal until another command is issued.
8. After the Erase Suspend command read non-erasing memory blocks as normal, issue Auto Select and Program commands on non-erasing blocks as normal.
9. After the Erase Resume command the suspended Erase operation resumes, read the Status Register until the Program/Erase Controller completes and the memory returns to Read Mode.
10. CFI Query command is valid when device is ready to read array data or when device is in autoselected mode.

Table 5. Commands, 8-bit mode, $\overline{\text{BYTE}} = V_{\text{IL}}$ (1)(2)

Command	Length	Bus Write Operations											
		1st		2nd		3rd		4th		5th		6th	
		Addr	Data	Addr	Data	Addr	Data	Addr	Data	Addr	Data	Addr	Data
Read/Reset ⁽³⁾	1	X	F0										
	3	AAA	AA	555	55	X	F0						
Auto Select ⁽⁴⁾	3	AAA	AA	555	55	AAA	90						
Program ⁽⁵⁾	4	AAA	AA	555	55	AAA	A0	PA	PD				
Unlock Bypass ⁽⁶⁾	3	AAA	AA	555	55	AAA	20						
Unlock Bypass Program ⁽⁵⁾	2	X	A0	PA	PD								
Unlock Bypass Reset ⁽⁷⁾	2	X	90	X	00								
Chip Erase ⁽⁵⁾	6	AAA	AA	555	55	AAA	80	AAA	AA	555	55	AAA	10
Block Erase ⁽⁵⁾	6+	AAA	AA	555	55	AAA	80	AAA	AA	555	55	BA	30
Erase Suspend ⁽⁸⁾	1	X	B0										
Erase Resume ⁽⁹⁾	1	X	30										
Read CFI Query ⁽¹⁰⁾	1	AA	98										

1. X Don't Care, PA Program Address, PD Program Data, BA Any address in the Block. All values in the table are in hexadecimal.
2. The Command Interface only uses A-1, A0-A10 and DQ0-DQ7 to verify the commands; A11-A20, DQ8-DQ14 and DQ15 are Don't Care. DQ15A-1 is A-1 when $\overline{\text{BYTE}} = V_{\text{IL}}$ or DQ15 when $\overline{\text{BYTE}} = V_{\text{IH}}$.
3. After a Read/Reset command, read the memory as normal until another command is issued. Read/Reset command is ignored during algorithm execution.
4. After an Auto Select command, read Manufacturer ID, Device ID or Block Protection Status.
5. After a Program, Unlock Bypass Program, Chip Erase, Block Erase command read the Status Register until the Program/Erase Controller completes and the memory returns to Read Mode. Add additional Blocks during Block Erase Command with additional Bus Write Operations until Timeout Bit is set.
6. After the Unlock Bypass command issue Unlock Bypass Program or Unlock Bypass Reset commands.
7. After the Unlock Bypass Reset command read the memory as normal until another command is issued.
8. After the Erase Suspend command read non-erasing memory blocks as normal, issue Auto Select and Program commands on non-erasing blocks as normal.
9. After the Erase Resume command the suspended Erase operation resumes, read the Status Register until the Program/Erase Controller completes and the memory returns to Read Mode.
10. The CFI Query command is valid when device is ready to read array data or when device is in autoselected mode.

Table 6. Program, Erase Times and Program, Erase Endurance Cycles

Parameter	Min	Typ ⁽¹⁾⁽²⁾	Max ⁽²⁾	Unit
Chip Erase		40	200 ⁽³⁾	s
Block Erase (64 KBytes)		0.8	6 ⁽⁴⁾	s
Erase Suspend Latency Time		15	25 ⁽⁴⁾	μs
Program (Byte or Word)		10	200 ⁽³⁾	μs
Accelerated Program (Byte or Word)		8	150 ⁽³⁾	μs
Chip Program (Byte by Byte)		40	200 ⁽³⁾	s
Chip Program (Word by Word)		20	100 ⁽³⁾	s
Program/Erase Cycles (per Block)	100,000			cycles
Data Retention	20			years

1. Typical values measured at room temperature and nominal voltages.
2. Sampled, but not 100% tested.
3. Maximum value measured at worst case conditions for both temperature and V_{CC} after 100,00 program/erase cycles.
4. Maximum value measured at worst case conditions for both temperature and V_{CC} .

5 Status Register

Bus Read operations from any address always read the Status Register during Program and Erase operations. It is also read during Erase Suspend when an address within a block being erased is accessed.

The bits in the Status Register are summarized in [Table 7: Status Register Bits](#).

5.1 Data Polling Bit (DQ7)

The Data Polling Bit can be used to identify whether the Program/Erase Controller has successfully completed its operation or if it has responded to an Erase Suspend. The Data Polling Bit is output on DQ7 when the Status Register is read.

During Program operations the Data Polling Bit outputs the complement of the bit being programmed to DQ7. After successful completion of the Program operation the memory returns to Read mode and Bus Read operations from the address just programmed output DQ7, not its complement.

During Erase operations the Data Polling Bit outputs '0', the complement of the erased state of DQ7. After successful completion of the Erase operation the memory returns to Read Mode.

In Erase Suspend mode the Data Polling Bit will output a '1' during a Bus Read operation within a block being erased. The Data Polling Bit will change from a '0' to a '1' when the Program/Erase Controller has suspended the Erase operation.

[Figure 6: Data Polling Flowchart](#), gives an example of how to use the Data Polling Bit. A Valid Address is the address being programmed or an address within the block being erased.

5.2 Toggle Bit (DQ6)

The Toggle Bit can be used to identify whether the Program/Erase Controller has successfully completed its operation or if it has responded to an Erase Suspend. The Toggle Bit is output on DQ6 when the Status Register is read.

During Program and Erase operations the Toggle Bit changes from '0' to '1' to '0', etc., with successive Bus Read operations at any address. After successful completion of the operation the memory returns to Read mode.

During Erase Suspend mode the Toggle Bit will output when addressing a cell within a block being erased. The Toggle Bit will stop toggling when the Program/Erase Controller has suspended the Erase operation.

If any attempt is made to erase a protected block, the operation is aborted, no error is signalled and DQ6 toggles for approximately 100µs. If any attempt is made to program a protected block or a suspended block, the operation is aborted, no error is signalled and DQ6 toggles for approximately 1µs.

[Figure 7: Data Toggle Flowchart](#), gives an example of how to use the Data Toggle Bit.

5.3 Error Bit (DQ5)

The Error Bit can be used to identify errors detected by the Program/Erase Controller. The Error Bit is set to '1' when a Program, Block Erase or Chip Erase operation fails to write the correct data to the memory. If the Error Bit is set a Read/Reset command must be issued before other commands are issued. The Error bit is output on DQ5 when the Status Register is read.

Note that the Program command cannot change a bit set to '0' back to '1' and attempting to do so will set DQ5 to '1'. A Bus Read operation to that address will show the bit is still '0'. One of the Erase commands must be used to set all the bits in a block or in the whole memory from '0' to '1'.

5.4 Erase Timer Bit (DQ3)

The Erase Timer Bit can be used to identify the start of Program/Erase Controller operation during a Block Erase command. Once the Program/Erase Controller starts erasing the Erase Timer Bit is set to '1'. Before the Program/Erase Controller starts the Erase Timer Bit is set to '0' and additional blocks to be erased may be written to the Command Interface. The Erase Timer Bit is output on DQ3 when the Status Register is read.

5.5 Alternative Toggle Bit (DQ2)

The Alternative Toggle Bit can be used to monitor the Program/Erase controller during Erase operations. The Alternative Toggle Bit is output on DQ2 when the Status Register is read.

During Chip Erase and Block Erase operations the Toggle Bit changes from '0' to '1' to '0', etc., with successive Bus Read operations from addresses within the blocks being erased. A protected block is treated the same as a block not being erased. Once the operation completes the memory returns to Read mode.

During Erase Suspend the Alternative Toggle Bit changes from '0' to '1' to '0', etc. with successive Bus Read operations from addresses within the blocks being erased. Bus Read operations to addresses within blocks not being erased will output the memory cell data as if in Read mode.

After an Erase operation that causes the Error Bit to be set the Alternative Toggle Bit can be used to identify which block or blocks have caused the error. The Alternative Toggle Bit changes from '0' to '1' to '0', etc. with successive Bus Read Operations from addresses within blocks that have not erased correctly. The Alternative Toggle Bit does not change if the addressed block has erased correctly.

Table 7. Status Register Bits⁽¹⁾

Operation	Address	DQ7	DQ6	DQ5	DQ3	DQ2	R \bar{B}
Program	Any Address	$\overline{DQ7}$	Toggle	0	–	–	0
Program During Erase Suspend	Any Address	$\overline{DQ7}$	Toggle	0	–	–	0
Program Error	Any Address	$\overline{DQ7}$	Toggle	1	–	–	0
Chip Erase	Any Address	0	Toggle	0	1	Toggle	0
Block Erase before timeout	Erasing Block	0	Toggle	0	0	Toggle	0
	Non-Erasing Block	0	Toggle	0	0	No Toggle	0
Block Erase	Erasing Block	0	Toggle	0	1	Toggle	0
	Non-Erasing Block	0	Toggle	0	1	No Toggle	0
Erase Suspend	Erasing Block	1	No Toggle	0	–	Toggle	1
	Non-Erasing Block	Data read as normal					
Erase Error	Good Block Address	0	Toggle	1	1	No Toggle	0
	Faulty Block Address	0	Toggle	1	1	Toggle	0

1. Unspecified data bits should be ignored.

Figure 6. Data Polling Flowchart

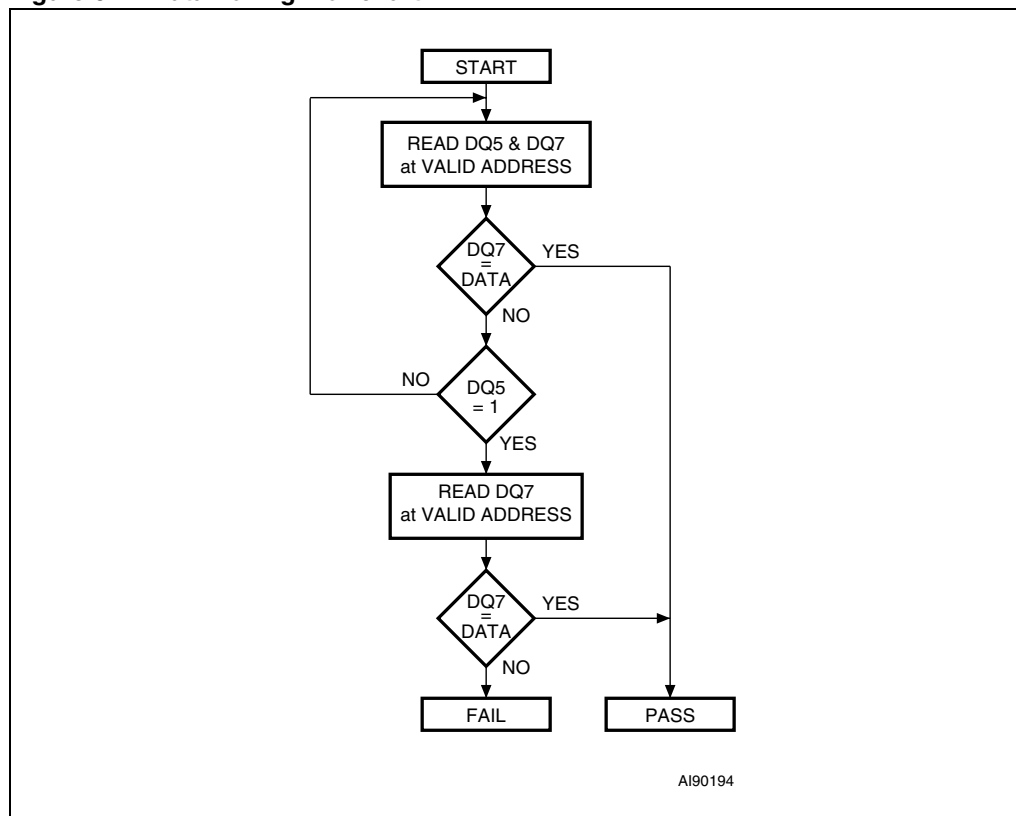
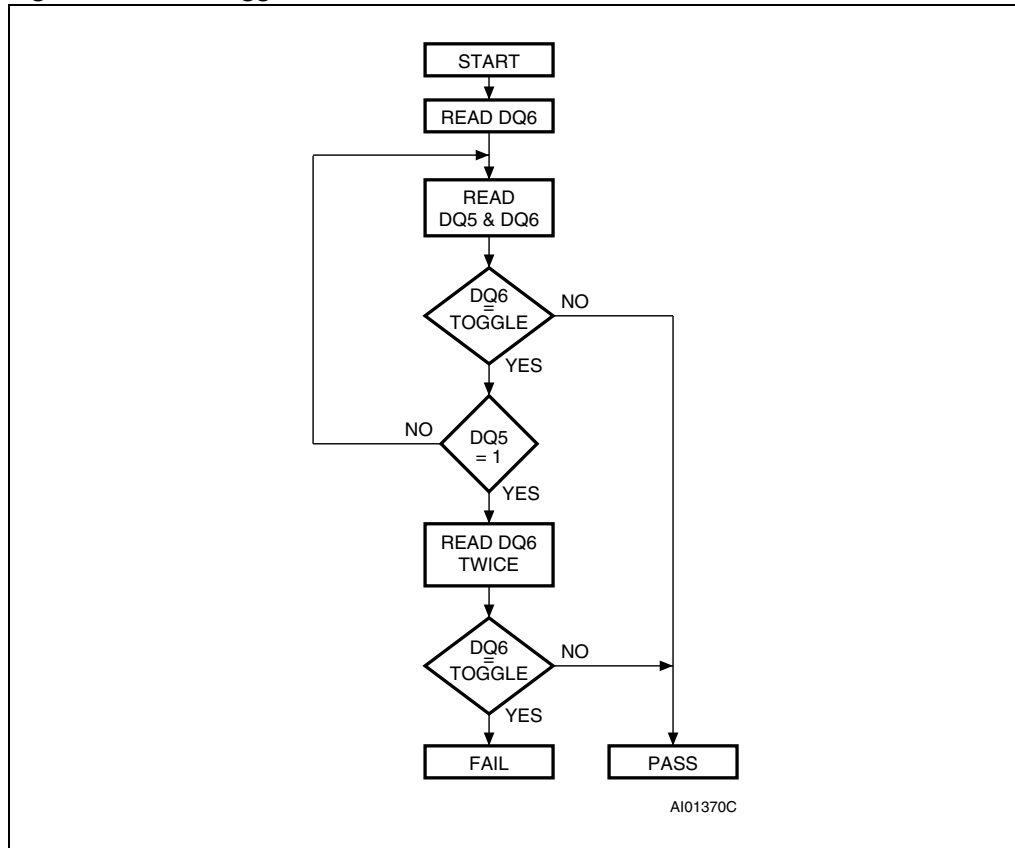

Figure 7. Data Toggle Flowchart



6 Maximum rating

Stressing the device above the rating listed in the Absolute Maximum Ratings table may cause permanent damage to the device. Exposure to Absolute Maximum Rating conditions for extended periods may affect device reliability. These are stress ratings only and operation of the device at these or any other conditions above those indicated in the Operating sections of this specification is not implied. Refer also to the STMicroelectronics SURE Program and other relevant quality documents.

Table 8. Absolute Maximum Ratings

Symbol	Parameter	Min	Max	Unit
T _{BIAS}	Temperature Under Bias	-50	125	°C
T _{STG}	Storage Temperature	-65	150	°C
V _{IO}	Input or Output Voltage ⁽¹⁾⁽²⁾	-0.6	V _{CC} +0.6	V
V _{CC}	Supply Voltage	-0.6	4	V
V _{ID}	Identification Voltage	-0.6	13.5	V
V _{PP}	Program Voltage	-0.6	13.5	V

1. Minimum voltage may undershoot to -2V during transition and for less than 20ns during transitions.
2. Maximum voltage may overshoot to V_{CC} +2V during transition and for less than 20ns during transitions.

7 DC and AC parameters

This section summarizes the operating measurement conditions, and the DC and AC characteristics of the device. The parameters in the DC and AC characteristics Tables that follow, are derived from tests performed under the Measurement Conditions summarized in [Table 9: Operating and AC Measurement Conditions](#). Designers should check that the operating conditions in their circuit match the operating conditions when relying on the quoted parameters.

Table 9. Operating and AC Measurement Conditions

Parameter	M29W320D				Unit
	70		90		
	Min	Max	Min	Max	
V_{CC} Supply Voltage	3.0	3.6	2.7	3.6	V
Ambient Operating Temperature	-40	85	-40	85	°C
Load Capacitance (C_L)	30		30		pF
Input Rise and Fall Times		10		10	ns
Input Pulse Voltages	0 to V_{CC}		0 to V_{CC}		V
Input and Output Timing Ref. Voltages	$V_{CC}/2$		$V_{CC}/2$		V

Figure 8. AC Measurement I/O Waveform

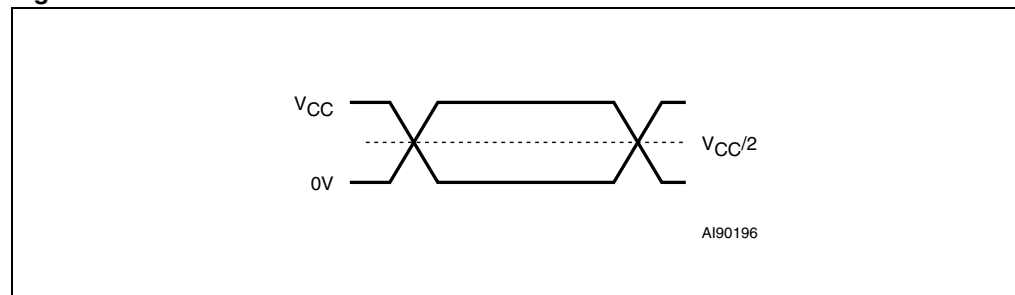
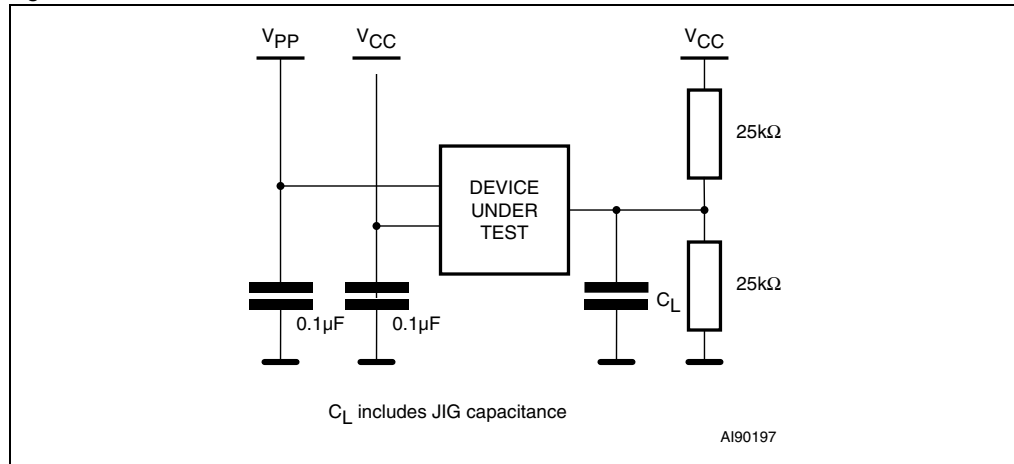

Figure 1. AC Measurement Load Circuit

Table 10. Device Capacitance⁽¹⁾

Symbol	Parameter	Test Condition	Min	Max	Unit
C_{IN}	Input Capacitance	$V_{IN} = 0\text{V}$		6	pF
C_{OUT}	Output Capacitance	$V_{OUT} = 0\text{V}$		12	pF

1. Sampled only, not 100% tested.

Table 11. DC Characteristics

Symbol	Parameter	Test Condition	Min	Typ.	Max	Unit
I_{LI}	Input Leakage Current	$0V \leq V_{IN} \leq V_{CC}$			± 1	μA
I_{LO}	Output Leakage Current	$0V \leq V_{OUT} \leq V_{CC}$			± 1	μA
I_{CC1}	Supply Current (Read)	$\bar{E} = V_{IL}, \bar{G} = V_{IH},$ $f = 6MHz$		5	10	mA
I_{CC2}	Supply Current (Standby)	$\bar{E} = V_{CC} \pm 0.2V,$ $\bar{RP} = V_{CC} \pm 0.2V$		35	100	μA
$I_{CC3}^{(1)}$	Supply Current (Program/Erase)	Program/Eraser Controller active			20	mA
			$V_{PP}/\bar{WP} =$ $V_{IL} \text{ or } V_{IH}$			
					20	mA
V_{IL}	Input Low Voltage		-0.5		0.8	V
V_{IH}	Input High Voltage		$0.7V_{CC}$		$V_{CC} + 0.3$	V
V_{PP}	Voltage for V_{PP}/\bar{WP} Program Acceleration	$V_{CC} = 3.0V \pm 10\%$	11.5		12.5	V
I_{PP}	Current for V_{PP}/\bar{WP} Program Acceleration	$V_{CC} = 3.0V \pm 10\%$			10	mA
V_{OL}	Output Low Voltage	$I_{OL} = 1.8mA$			0.45	V
V_{OH}	Output High Voltage	$I_{OH} = -100\mu A$	$V_{CC} - 0.4$			V
V_{ID}	Identification Voltage		11.5		12.5	V
I_{ID}	Identification Current	$A9 = V_{ID}$			100	μA
V_{LKO}	Program/Erase Lockout Supply Voltage		1.8		2.3	V

1. Sampled only, not 100% tested.

Figure 9. Read Mode AC Waveforms

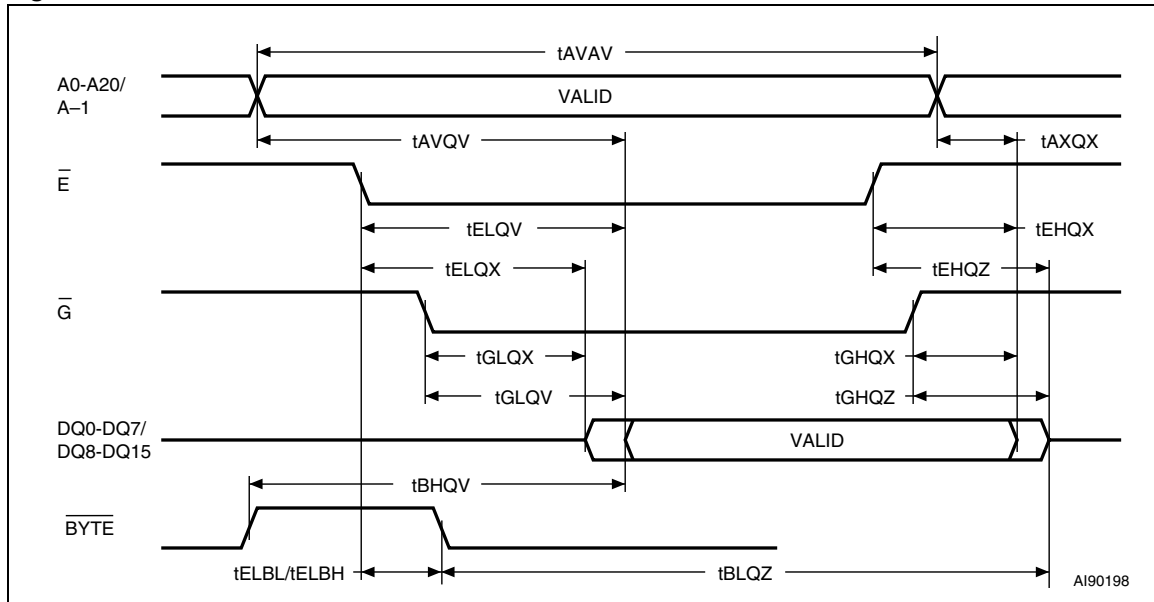

Table 12. Read AC Characteristics

Symbol	Alt	Parameter	Test Condition	M29W320D		Unit	
				70	90		
t_{AVAV}	t_{RC}	Address Valid to Next Address Valid	$\bar{E} = V_{IL}$, $\bar{G} = V_{IL}$	Min	70	90	ns
t_{AVQV}	t_{ACC}	Address Valid to Output Valid	$\bar{E} = V_{IL}$, $\bar{G} = V_{IL}$	Max	70	90	ns
$t_{ELQX}^{(1)}$	t_{LZ}	Chip Enable Low to Output Transition	$\bar{G} = V_{IL}$	Min	0	0	ns
t_{ELQV}	t_{CE}	Chip Enable Low to Output Valid	$\bar{G} = V_{IL}$	Max	70	90	ns
$t_{GLQX}^{(1)}$	t_{OLZ}	Output Enable Low to Output Transition	$\bar{E} = V_{IL}$	Min	0	0	ns
t_{GLQV}	t_{OE}	Output Enable Low to Output Valid	$\bar{E} = V_{IL}$	Max	30	35	ns
$t_{EHQZ}^{(1)}$	t_{HZ}	Chip Enable High to Output Hi-Z	$\bar{G} = V_{IL}$	Max	25	30	ns
$t_{GHQZ}^{(1)}$	t_{DF}	Output Enable High to Output Hi-Z	$\bar{E} = V_{IL}$	Max	25	30	ns
t_{EHQX} t_{GHQX} t_{AXQX}	t_{OH}	Chip Enable, Output Enable or Address Transition to Output Transition		Min	0	0	ns
t_{ELBL} t_{ELBH}	t_{ELFL} t_{ELFH}	Chip Enable to \overline{BYTE} Low or High		Max	5	5	ns
t_{BLQZ}	t_{FLQZ}	\overline{BYTE} Low to Output Hi-Z		Max	25	30	ns
t_{BHQV}	t_{FHQV}	\overline{BYTE} High to Output Valid		Max	30	40	ns

1. Sampled only, not 100% tested.

Figure 10. Write AC Waveforms, Write Enable Controlled

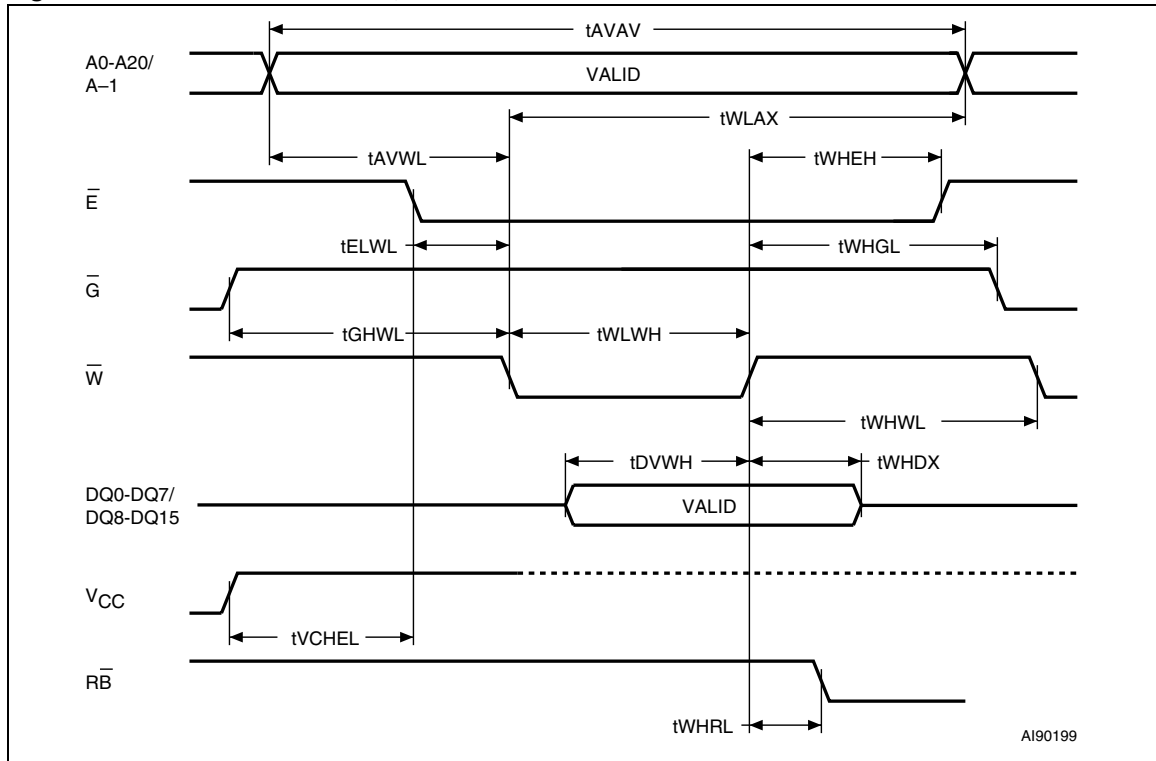

Table 13. Write AC Characteristics, Write Enable Controlled

Symbol	Alt	Parameter	Min	M29W320D		Unit
				70	90	
t_{AVAV}	t_{WC}	Address Valid to Next Address Valid	Min	70	90	ns
t_{ELWL}	t_{CS}	Chip Enable Low to Write Enable Low	Min	0	0	ns
t_{LWHL}	t_{WP}	Write Enable Low to Write Enable High	Min	45	50	ns
t_{DVWH}	t_{DS}	Input Valid to Write Enable High	Min	45	50	ns
t_{WHDX}	t_{DH}	Write Enable High to Input Transition	Min	0	0	ns
t_{WHEH}	t_{CH}	Write Enable High to Chip Enable High	Min	0	0	ns
t_{WHWL}	t_{WPH}	Write Enable High to Write Enable Low	Min	30	30	ns
t_{AVWL}	t_{AS}	Address Valid to Write Enable Low	Min	0	0	ns
t_{WLAX}	t_{AH}	Write Enable Low to Address Transition	Min	45	50	ns
t_{GHWL}		Output Enable High to Write Enable Low	Min	0	0	ns
t_{WHGL}	t_{OEH}	Write Enable High to Output Enable Low	Min	0	0	ns
$t_{WHLR}^{(1)}$	t_{BUSY}	Program/Erase Valid to \overline{RB} Low	Max	30	35	ns
t_{VCHL}	t_{VCS}	V_{CC} High to Chip Enable Low	Min	50	50	μ s

1. Sampled only, not 100% tested.

Figure 11. Write AC Waveforms, Chip Enable Controlled

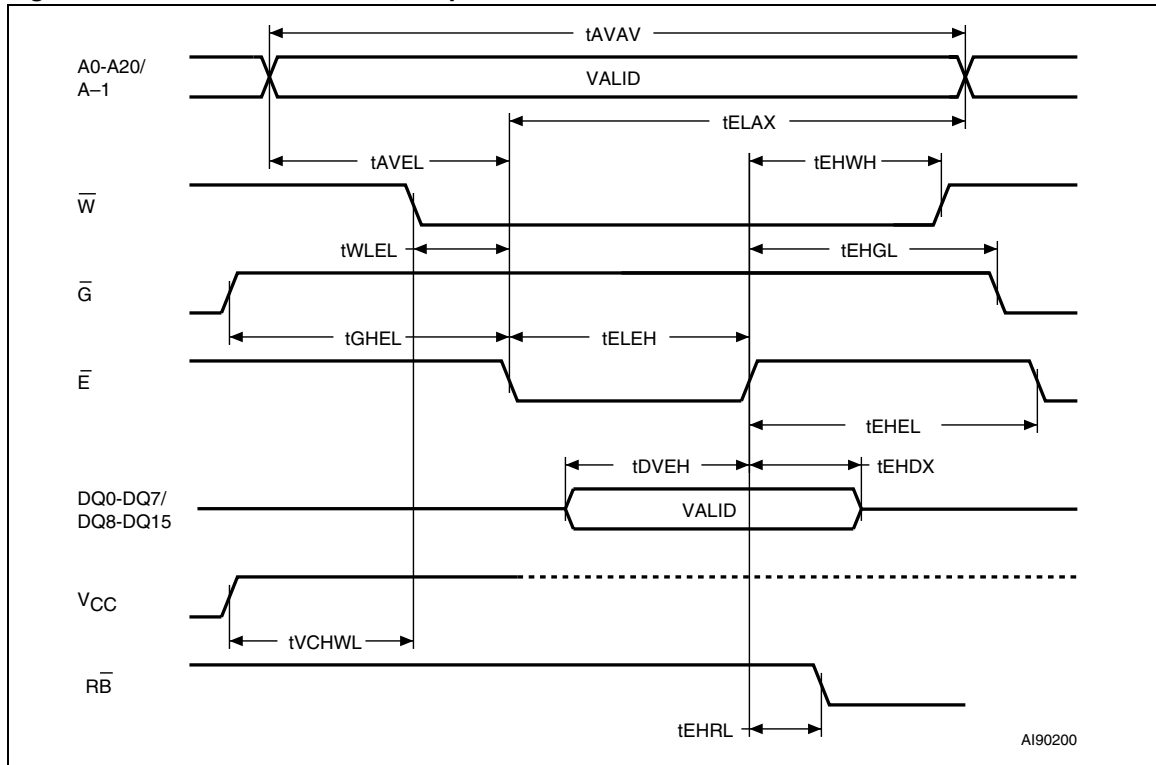

Table 14. Write AC Characteristics, Chip Enable Controlled

Symbol	Alt	Parameter		M29W320D		Unit
				70	90	
t_{AVAV}	t_{WC}	Address Valid to Next Address Valid	Min	70	90	ns
t_{WLEL}	t_{WS}	Write Enable Low to Chip Enable Low	Min	0	0	ns
t_{ELEH}	t_{CP}	Chip Enable Low to Chip Enable High	Min	45	50	ns
t_{DVEH}	t_{DS}	Input Valid to Chip Enable High	Min	45	50	ns
t_{EHDX}	t_{DH}	Chip Enable High to Input Transition	Min	0	0	ns
t_{EHWH}	t_{WH}	Chip Enable High to Write Enable High	Min	0	0	ns
t_{EHEL}	t_{CPH}	Chip Enable High to Chip Enable Low	Min	30	30	ns
t_{AVEL}	t_{AS}	Address Valid to Chip Enable Low	Min	0	0	ns
t_{ELAX}	t_{AH}	Chip Enable Low to Address Transition	Min	45	50	ns
t_{GHEL}		Output Enable High Chip Enable Low	Min	0	0	ns
t_{EHGL}	t_{OEH}	Chip Enable High to Output Enable Low	Min	0	0	ns
$t_{EHRL}^{(1)}$	t_{BUSY}	Program/Erase Valid to \overline{RB} Low	Max	30	35	ns
t_{VCHWL}	t_{VCS}	V_{CC} High to Write Enable Low	Min	50	50	μ s

1. Sampled only, not 100% tested.

Figure 12. Reset/Block Temporary Unprotect AC Waveforms

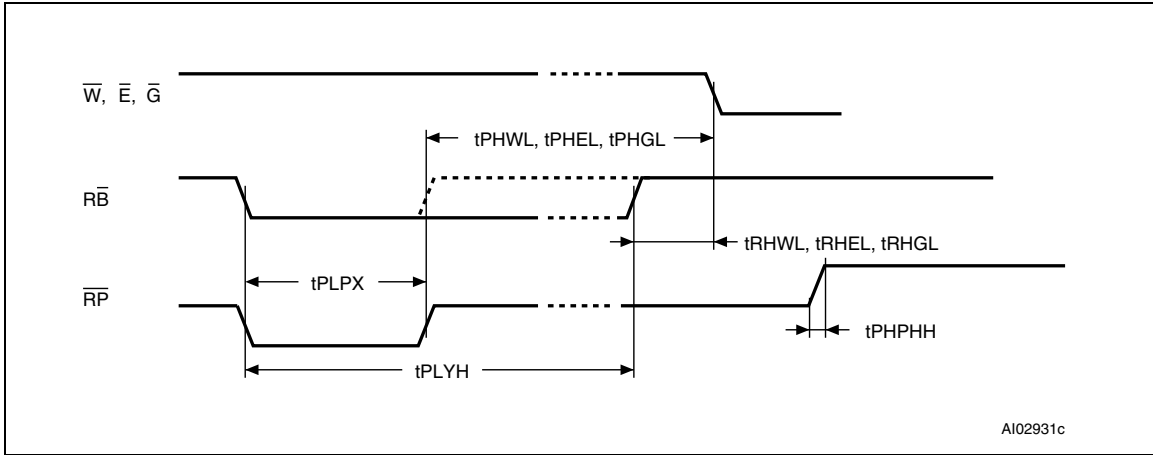
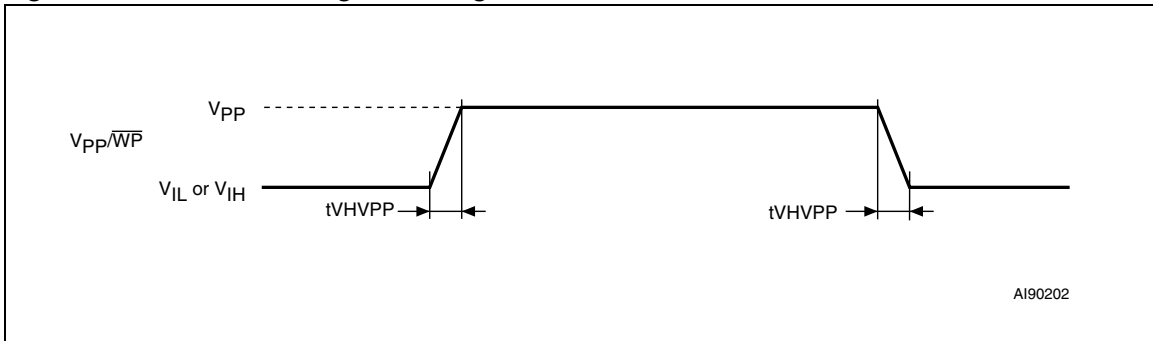

Table 15. Reset/Block Temporary Unprotect AC Characteristics

Symbol	Alt	Parameter		M29W320D		Unit
				70	90	
$t_{PHWL}^{(1)}$ $t_{PHEL}^{(1)}$ $t_{PHGL}^{(1)}$	t_{RH}	\overline{RP} High to Write Enable Low, Chip Enable Low, Output Enable Low	Min	50	50	ns
$t_{RHWL}^{(1)}$ $t_{RHEL}^{(1)}$ $t_{RHGL}^{(1)}$	t_{RB}	\overline{RB} High to Write Enable Low, Chip Enable Low, Output Enable Low	Min	0	0	ns
t_{PLPX}	t_{RP}	\overline{RP} Pulse Width	Min	500	500	ns
$t_{PLYH}^{(1)}$	t_{READY}	\overline{RP} Low to Read Mode	Max	25	25	μ s
$t_{PHPHH}^{(1)}$	t_{VIDR}	\overline{RP} Rise Time to V_{ID}	Min	500	500	ns
$t_{VHVPP}^{(1)}$		V_{PP} Rise and Fall Time	Min	250	250	ns

1. Sampled only, not 100% tested.

Figure 13. Accelerated Program Timing Waveforms



8 Package mechanical

Figure 14. TSOP48 Lead Plastic Thin Small Outline, 12x20 Mm, Top View Package Outline

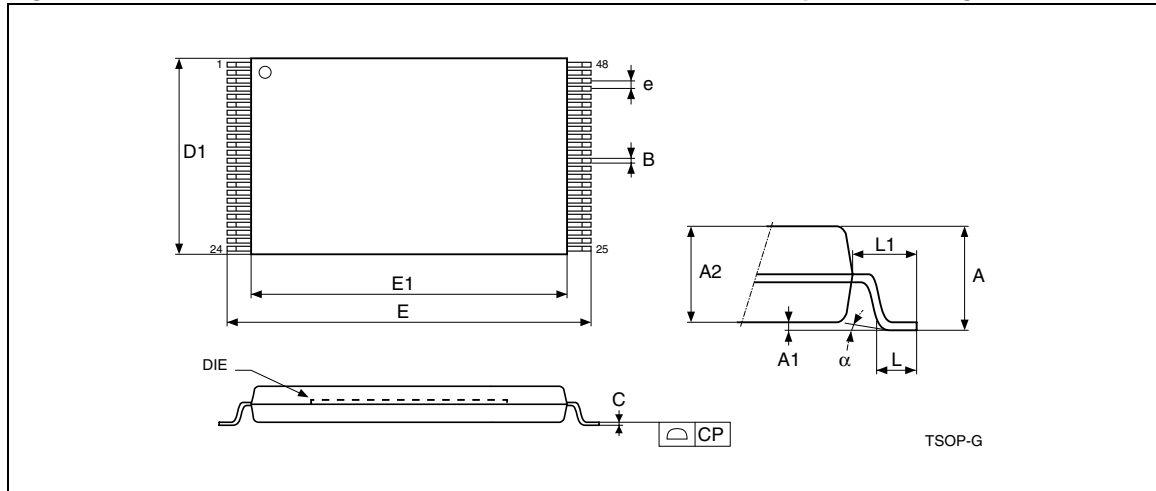

1. Drawing not to scale.

Table 16. TSOP48 Lead Plastic Thin Small Outline, 12x20 mm, Package Mechanical Data

Symbol	millimeters			inches		
	Typ	Min	Max	Typ	Min	Max
A			1.200			0.0472
A1	0.100	0.050	0.150	0.0039	0.0020	0.0059
A2	1.000	0.950	1.050	0.0394	0.0374	0.0413
B	0.220	0.170	0.270	0.0087	0.0067	0.0106
C		0.100	0.210		0.0039	0.0083
CP			0.080			0.0031
D1	12.000	11.900	12.100	0.4724	0.4685	0.4764
E	20.000	19.800	20.200	0.7874	0.7795	0.7953
E1	18.400	18.300	18.500	0.7244	0.7205	0.7283
e	0.500	–	–	0.0197	–	–
L	0.600	0.500	0.700	0.0236	0.0197	0.0276
L1	0.800			0.0315		
a	3	0	5	3	0	5

Figure 15. TFBGA48 6x8mm - 6x8 Ball Array, 0.8mm Pitch, Bottom View Package Outline

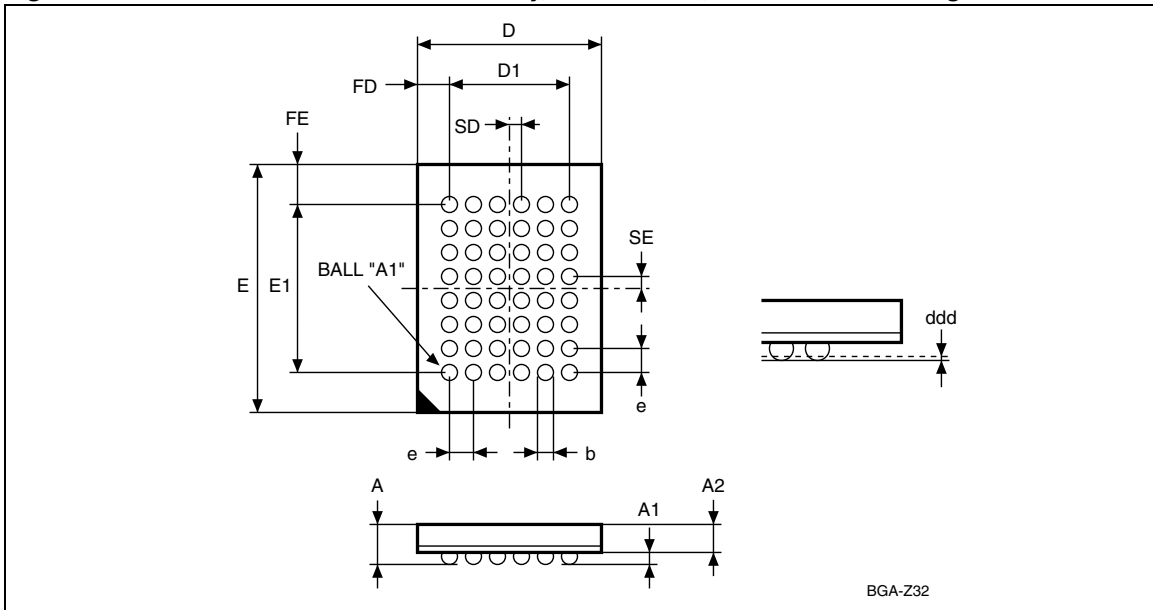

1. Drawing not to scale.

Table 17. TFBGA48 6x8mm - 6x8 Ball Array, 0.8mm Pitch, Package Mechanical Data

Symbol	millimeters			inches		
	Typ	Min	Max	Typ	Min	Max
A			1.200			0.0472
A1		0.260			0.0102	
A2			0.900			0.0354
b		0.350	0.450		0.0138	0.0177
D	6.000	5.900	6.100	0.2362	0.2323	0.2402
D1	4.000	–	–	0.1575	–	–
ddd			0.100			0.0039
E	8.000	7.900	8.100	0.3150	0.3110	0.3189
E1	5.600	–	–	0.2205	–	–
e	0.800	–	–	0.0315	–	–
FD	1.000	–	–	0.0394	–	–
FE	1.200	–	–	0.0472	–	–
SD	0.400	–	–	0.0157	–	–
SE	0.400	–	–	0.0157	–	–

9 Part numbering

Table 18. Ordering Information Scheme

Example:

M29W320DB 90 N 1 T

Device Type

M29

Operating Voltage

W = $V_{CC} = 2.7$ to $3.6V$

Device Function

320D = 32 Mbit (x8/x16), Non-Uniform Parameter Blocks, Boot Block

Array Matrix

T = Top Boot

B = Bottom Boot

Speed

70 = 70 ns

90 = 90 ns

Package

N = TSOP48: 12 x 20 mm

ZE = TFBGA48: 6 x 8mm, 0.8mm pitch

Temperature Range

1 = 0 to 70 °C

6 = -40 to 85 °C

Option

Blank = Standard Packing

T = Tape & Reel Packing

E = ECOPACK Package, Standard Packing

F = ECOPACK Package, Tape & Reel Packing

Devices are shipped from the factory with the memory content bits erased to '1'.

For a list of available options (Speed, Package, etc...) or for further information on any aspect of this device, please contact the ST Sales Office nearest to you.

Appendix A Block Addresses

Table 19. Top Boot Block Addresses, M29W320DT

#	Size (KByte/KWord)	Address Range (x8)	Address Range (x16)
66	16/8	3FC000h-3FFFFFFh	1FE000h-1FFFFFFh
65	8/4	3FA000h-3FBFFFh	1FD000h-1FDFFFh
64	8/4	3F8000h-3F9FFFh	1FC000h-1FCFFFh
63	32/16	3F0000h-3F7FFFh	1F8000h-1FBFFFh
62	64/32	3E0000h-3EFFFFh	1F0000h-1F7FFFh
61	64/32	3D0000h-3DFFFFh	1E8000h-1EFFFFh
60	64/32	3C0000h-3CFFFFh	1E0000h-1E7FFFh
59	64/32	3B0000h-3BFFFFh	1D8000h-1DFFFFh
58	64/32	3A0000h-3AFFFFh	1D0000h-1D7FFFh
57	64/32	390000h-39FFFFh	1C8000h-1CFFFFh
56	64/32	380000h-38FFFFh	1C0000h-1C7FFFh
55	64/32	370000h-37FFFFh	1B8000h-1BFFFFh
54	64/32	360000h-36FFFFh	1B0000h-1B7FFFh
53	64/32	350000h-35FFFFh	1A8000h-1AFFFFh
52	64/32	340000h-34FFFFh	1A0000h-1A7FFFh
51	64/32	330000h-33FFFFh	198000h-19FFFFh
50	64/32	320000h-32FFFFh	190000h-197FFFh
49	64/32	310000h-31FFFFh	188000h-18FFFFh
48	64/32	300000h-30FFFFh	180000h-187FFFh
47	64/32	2F0000h-2FFFFFFh	178000h-17FFFFh
46	64/32	2E0000h-2EFFFFh	170000h-177FFFh
45	64/32	2D0000h-2DFFFFh	168000h-16FFFFh
44	64/32	2C0000h-2CFFFFh	160000h-167FFFh
43	64/32	2B0000h-2BFFFFh	158000h-15FFFFh
42	64/32	2A0000h-2AFFFFh	150000h-157FFFh
41	64/32	290000h-29FFFFh	148000h-14FFFFh
40	64/32	280000h-28FFFFh	140000h-147FFFh
39	64/32	270000h-27FFFFh	138000h-13FFFFh
38	64/32	260000h-26FFFFh	130000h-137FFFh
37	64/32	250000h-25FFFFh	128000h-12FFFFh
36	64/32	240000h-24FFFFh	120000h-127FFFh

Table 19. Top Boot Block Addresses, M29W320DT (continued)

35	64/32	230000h-23FFFFh	118000h-11FFFFh
34	64/32	220000h-22FFFFh	110000h-117FFFh
33	64/32	210000h-21FFFFh	108000h-10FFFFh
32	64/32	200000h-20FFFFh	100000h-107FFFh
31	64/32	1F0000h-1FFFFFh	0F8000h-0FBFFFh
30	64/32	1E0000h-1EFFFFh	0F0000h-0F7FFFh
29	64/32	1D0000h-1DFFFFh	0E8000h-0EFFFFh
28	64/32	1C0000h-1CFFFFh	0E0000h-0E7FFFh
27	64/32	1B0000h-1BFFFFh	0D8000h-0DFFFFh
26	64/32	1A0000h-1AFFFFh	0D0000h-0D7FFFh
25	64/32	190000h-19FFFFh	0C8000h-0CFFFFh
24	64/32	180000h-18FFFFh	0C0000h-0C7FFFh
23	64/32	170000h-17FFFFh	0B8000h-0BFFFFh
22	64/32	160000h-16FFFFh	0B0000h-0B7FFFh
21	64/32	150000h-15FFFFh	0A8000h-0AFFFFh
20	64/32	140000h-14FFFFh	0A0000h-0A7FFFh
19	64/32	130000h-13FFFFh	098000h-09FFFFh
18	64/32	120000h-12FFFFh	090000h-097FFFh
17	64/32	110000h-11FFFFh	088000h-08FFFFh
16	64/32	100000h-10FFFFh	080000h-087FFFh
15	64/32	0F0000h-0FFFFFh	078000h-07FFFFh
14	64/32	0E0000h-0EFFFFh	070000h-077FFFh
13	64/32	0D0000h-0DFFFFh	068000h-06FFFFh
12	64/32	0C0000h-0CFFFFh	060000h-067FFFh
11	64/32	0B0000h-0BFFFFh	058000h-05FFFFh
10	64/32	0A0000h-0AFFFFh	050000h-057FFFh
9	64/32	090000h-09FFFFh	048000h-04FFFFh
8	64/32	080000h-08FFFFh	040000h-047FFFh
7	64/32	070000h-07FFFFh	038000h-03FFFFh
6	64/32	060000h-06FFFFh	030000h-037FFFh
5	64/32	050000h-05FFFFh	028000h-02FFFFh
4	64/32	040000h-04FFFFh	020000h-027FFFh
3	64/32	030000h-03FFFFh	018000h-01FFFFh
2	64/32	020000h-02FFFFh	010000h-017FFFh
1	64/32	010000h-01FFFFh	008000h-00FFFFh
0	64/32	000000h-00FFFFh	000000h-007FFFh

Table 20. Bottom Boot Block Addresses, M29W320DB

#	Size (KByte/KWord)	Address Range (x8)	Address Range (x16)
66	64/32	3F0000h-3FFFFFFh	1F8000h-1FFFFFFh
65	64/32	3E0000h-3FFFFFFh	1F0000h-1F7FFFh
64	64/32	3D0000h-3FFFFFFh	1E8000h-1EFFFFh
63	64/32	3C0000h-3FFFFFFh	1E0000h-1E7FFFh
62	64/32	3B0000h-3FFFFFFh	1D8000h-1DFFFFh
61	64/32	3A0000h-3FFFFFFh	1D0000h-1D7FFFh
60	64/32	390000h-3FFFFFFh	1C8000h-1CFFFFh
59	64/32	380000h-3FFFFFFh	1C0000h-1C7FFFh
58	64/32	370000h-3FFFFFFh	1B8000h-1BFFFFh
57	64/32	360000h-3FFFFFFh	1B0000h-1B7FFFh
56	64/32	350000h-3FFFFFFh	1A8000h-1AFFFFh
55	64/32	340000h-3FFFFFFh	1A0000h-1A7FFFh
54	64/32	330000h-3FFFFFFh	198000h-19FFFFh
53	64/32	320000h-3FFFFFFh	190000h-197FFFh
52	64/32	310000h-3FFFFFFh	188000h-18FFFFh
51	64/32	300000h-3FFFFFFh	180000h-187FFFh
50	64/32	2F0000h-2FFFFFFh	178000h-17FFFFh
49	64/32	2E0000h-2FFFFFFh	170000h-177FFFh
48	64/32	2D0000h-2FFFFFFh	168000h-16FFFFh
47	64/32	2C0000h-2FFFFFFh	160000h-167FFFh
46	64/32	2B0000h-2FFFFFFh	158000h-15FFFFh
45	64/32	2A0000h-2FFFFFFh	150000h-157FFFh
44	64/32	290000h-2FFFFFFh	148000h-14FFFFh
43	64/32	280000h-2FFFFFFh	140000h-147FFFh
42	64/32	270000h-2FFFFFFh	138000h-13FFFFh
41	64/32	260000h-2FFFFFFh	130000h-137FFFh
40	64/32	250000h-2FFFFFFh	128000h-12FFFFh
39	64/32	240000h-2FFFFFFh	120000h-127FFFh
38	64/32	230000h-2FFFFFFh	118000h-11FFFFh
37	64/32	220000h-2FFFFFFh	110000h-117FFFh
36	64/32	210000h-2FFFFFFh	108000h-10FFFFh
35	64/32	200000h-2FFFFFFh	100000h-107FFFh
34	64/32	1F0000h-1FFFFFFh	0F8000h-0FBFFFh
33	64/32	1E0000h-1FFFFFFh	0F0000h-0F7FFFh

Table 20. Bottom Boot Block Addresses, M29W320DB (continued)

32	64/32	1D0000h-1DFFFFh	0E8000h-0EFFFFh
31	64/32	1C0000h-1CFFFFh	0E0000h-0E7FFFh
30	64/32	1B0000h-1BFFFFh	0D8000h-0DFFFFh
29	64/32	1A0000h-1AFFFFh	0D0000h-0D7FFFh
28	64/32	190000h-19FFFFh	0C8000h-0CFFFFh
27	64/32	180000h-18FFFFh	0C0000h-0C7FFFh
26	64/32	170000h-17FFFFh	0B8000h-0BFFFFh
25	64/32	160000h-16FFFFh	0B0000h-0B7FFFh
24	64/32	150000h-15FFFFh	0A8000h-0AFFFFh
23	64/32	140000h-14FFFFh	0A0000h-0A7FFFh
22	64/32	130000h-13FFFFh	098000h-09FFFFh
21	64/32	120000h-12FFFFh	090000h-097FFFh
20	64/32	110000h-11FFFFh	088000h-08FFFFh
19	64/32	100000h-10FFFFh	080000h-087FFFh
18	64/32	0F0000h-0FFFFFh	078000h-07FFFFh
17	64/32	0E0000h-0EFFFFh	070000h-077FFFh
16	64/32	0D0000h-0DFFFFh	068000h-06FFFFh
15	64/32	0C0000h-0CFFFFh	060000h-067FFFh
14	64/32	0B0000h-0BFFFFh	058000h-05FFFFh
13	64/32	0A0000h-0AFFFFh	050000h-057FFFh
12	64/32	090000h-09FFFFh	048000h-04FFFFh
11	64/32	080000h-08FFFFh	040000h-047FFFh
10	64/32	070000h-07FFFFh	038000h-03FFFFh
9	64/32	060000h-06FFFFh	030000h-037FFFh
8	64/32	050000h-05FFFFh	028000h-02FFFFh
7	64/32	040000h-04FFFFh	020000h-027FFFh
6	64/32	030000h-03FFFFh	018000h-01FFFFh
5	64/32	020000h-02FFFFh	010000h-017FFFh
4	64/32	010000h-01FFFFh	008000h-00FFFFh
3	32/16	008000h-00FFFFh	004000h-007FFFh
2	8/4	006000h-007FFFh	003000h-003FFFh
1	8/4	004000h-005FFFh	002000h-002FFFh
0	16/8	000000h-003FFFh	000000h-001FFFh

Appendix B Common Flash Interface (CFI)

The Common Flash Interface is a JEDEC approved, standardized data structure that can be read from the Flash memory device. It allows a system software to query the device to determine various electrical and timing parameters, density information and functions supported by the memory. The system can interface easily with the device, enabling the software to upgrade itself when necessary.

When the CFI Query Command is issued the device enters CFI Query mode and the data structure is read from the memory. [Table 21](#), [Table 22](#), [Table 23](#), [Table 24](#), [Table 25](#) and [Table 26](#) show the addresses used to retrieve the data. The CFI data structure also contains a security area where a 64 bit unique security number is written (see [Table 26](#), Security Code area). This area can be accessed only in Read mode by the final user. It is impossible to change the security number after it has been written by ST. Issue a Read command to return to Read mode.

Table 21. Query Structure Overview⁽¹⁾

Address		Sub-section Name	Description
x16	x8		
10h	20h	CFI Query Identification String	Command set ID and algorithm data offset
1Bh	36h	System Interface Information	Device timing & voltage information
27h	4Eh	Device Geometry Definition	Flash device layout
40h	80h	Primary Algorithm-specific Extended Query table	Additional information specific to the Primary Algorithm (optional)
61h	C2h	Security Code Area	64 bit unique device number

1. Query data are always presented on the lowest order data outputs.

Table 22. CFI Query Identification String⁽¹⁾

Address		Data	Description	Value
x16	x8			
10h	20h	0051h	Query Unique ASCII String "QRY"	"Q"
11h	22h	0052h		"R"
12h	24h	0059h		"Y"
13h	26h	0002h	Primary Algorithm Command Set and Control Interface ID code 16 bit ID code defining a specific algorithm	AMD Compatible
14h	28h	0000h		
15h	2Ah	0040h	Address for Primary Algorithm extended Query table (see Table 24)	P = 40h
16h	2Ch	0000h		
17h	2Eh	0000h	Alternate Vendor Command Set and Control Interface ID Code second vendor - specified algorithm supported	NA
18h	30h	0000h		
19h	32h	0000h	Address for Alternate Algorithm extended Query table	NA
1Ah	34h	0000h		

1. Query data are always presented on the lowest order data outputs (DQ7-DQ0) only. DQ8-DQ15 are '0'.

Table 23. CFI Query System Interface Information

Address		Data	Description	Value
x16	x8			
1Bh	36h	0027h	V _{CC} Logic Supply Minimum Program/Erase voltage bit 7 to 4BCD value in volts bit 3 to 0BCD value in 100 mV	2.7V
1Ch	38h	0036h	V _{CC} Logic Supply Maximum Program/Erase voltage bit 7 to 4BCD value in volts bit 3 to 0BCD value in 100 mV	3.6V
1Dh	3Ah	00B5h	V _{PP} [Programming] Supply Minimum Program/Erase voltage bit 7 to 4HEX value in volts bit 3 to 0BCD value in 100 mV	11.5V
1Eh	3Ch	00C5h	V _{PP} [Programming] Supply Maximum Program/Erase voltage bit 7 to 4HEX value in volts bit 3 to 0BCD value in 100 mV	12.5V
1Fh	3Eh	0004h	Typical timeout per single byte/word program = 2 ⁿ μs	16μs
20h	40h	0000h	Typical timeout for minimum size write buffer program = 2 ⁿ μs	NA
21h	42h	000Ah	Typical timeout per individual block erase = 2 ⁿ ms	1s
22h	44h	0000h	Typical timeout for full chip erase = 2 ⁿ ms	NA
23h	46h	0005h	Maximum timeout for byte/word program = 2 ⁿ times typical	512μs
24h	48h	0000h	Maximum timeout for write buffer program = 2 ⁿ times typical	NA
25h	4Ah	0004h	Maximum timeout per individual block erase = 2 ⁿ times typical	16s
26h	4Ch	0000h	Maximum timeout for chip erase = 2 ⁿ times typical	NA

Table 24. Device Geometry Definition

Address		Data	Description	Value
x16	x8			
27h	4Eh	0016h	Device Size = 2 ⁿ in number of bytes	4 MByte
28h	50h	0002h	Flash Device Interface Code description	x8, x16 Async.
29h	52h	0000h		
2Ah	54h	0000h	Maximum number of bytes in multi-byte program or page = 2 ⁿ	NA
2Bh	56h	0000h		
2Ch	58h	0004h	Number of Erase Block Regions within the device. It specifies the number of regions within the device containing contiguous Erase Blocks of the same size.	4
2Dh	5Ah	0000h	Region 1 Information	1
2Eh	5Ch	0000h	Number of identical size erase block = 0000h+1	
2Fh	5Eh	0040h	Region 1 Information	16 Kbyte
30h	60h	0000h	Block size in Region 1 = 0040h * 256 byte	

Table 24. Device Geometry Definition (continued)

Address		Data	Description	Value
x16	x8			
31h	62h	0001h	Region 2 Information	2
32h	64h	0000h	Number of identical size erase block = 0001h+1	
33h	66h	0020h	Region 2 Information	8 Kbyte
34h	68h	0000h	Block size in Region 2 = 0020h * 256 byte	
35h	6Ah	0000h	Region 3 Information	1
36h	6Ch	0000h	Number of identical size erase block = 0000h+1	
37h	6Eh	0080h	Region 3 Information	32 Kbyte
38h	70h	0000h	Block size in Region 3 = 0080h * 256 byte	
39h	72h	003Eh	Region 4 Information	63
3Ah	74h	0000h	Number of identical-size erase block = 003Eh+1	
3Bh	76h	0000h	Region 4 Information	64 Kbyte
3Ch	78h	0001h	Block size in Region 4 = 0100h * 256 byte	

Table 25. Primary Algorithm-Specific Extended Query Table

Address		Data	Description	Value
x16	x8			
40h	80h	0050h	Primary Algorithm extended Query table unique ASCII string "PRI"	"P"
41h	82h	0052h		"R"
42h	84h	0049h		"I"
43h	86h	0031h	Major version number, ASCII	"1"
44h	88h	0030h	Minor version number, ASCII	"0"
45h	8Ah	0000h	Address Sensitive Unlock (bits 1 to 0) 00 = required, 01 = not required Silicon Revision Number (bits 7 to 2)	Yes
46h	8Ch	0002h	Erase Suspend 00 = not supported, 01 = Read only, 02 = Read and Write	2
47h	8Eh	0001h	Block Protection 00 = not supported, x = number of blocks in per group	1
48h	90h	0001h	Temporary Block Unprotect 00 = not supported, 01 = supported	Yes
49h	92h	0004h	Block Protect /Unprotect 04 = M29W400B	4
4Ah	94h	0000h	Simultaneous Operations, 00 = not supported	No
4Bh	96h	0000h	Burst Mode, 00 = not supported, 01 = supported	No
4Ch	98h	0000h	Page Mode, 00 = not supported, 01 = 4 page word, 02 = 8 page word	No

Table 25. Primary Algorithm-Specific Extended Query Table (continued)

Address		Data	Description	Value
x16	x8			
4Dh	9Ah	00B5h	V _{PP} Supply Minimum Program/Erase voltage bit 7 to 4 HEX value in volts bit 3 to 0 BCD value in 100 mV	11.5V
4Eh	9Ch	00C5h	V _{PP} Supply Minimum Program/Erase voltage bit 7 to 4 HEX value in volts bit 3 to 0 BCD value in 100 mV	12.5V
4Fh	9Eh	000xh	Top/Bottom Boot Block Flag 02h = Bottom Boot device, 03h = Top Boot device	–

Table 26. Security Code Area

Address		Data	Description
x16	x8		
61h	C3h, C2h	XXXX	64 bit: unique device number
62h	C5h, C4h	XXXX	
63h	C7h, C6h	XXXX	
64h	C9h, C8h	XXXX	

Appendix C Block Protection

Block protection can be used to prevent any operation from modifying the data stored in the Flash. Each Block can be protected individually. Once protected, Program and Erase operations on the block fail to change the data.

There are three techniques that can be used to control Block Protection, these are the Programmer technique, the In-System technique and Temporary Unprotection. Temporary Unprotection is controlled by the Reset/Block Temporary Unprotection pin, \overline{RP} ; this is described in the Signal Descriptions section.

Unlike the Command Interface of the Program/Erase Controller, the techniques for protecting and unprotecting blocks change between different Flash memory suppliers. For example, the techniques for AMD parts will not work on STMicroelectronics parts. Care should be taken when changing drivers for one part to work on another.

C.1 Programmer Technique

The Programmer technique uses high (V_{ID}) voltage levels on some of the bus pins. These cannot be achieved using a standard microprocessor bus, therefore the technique is recommended only for use in Programming Equipment.

To protect a block follow the flowchart in [Figure 16: Programmer Equipment Block Protect Flowchart](#). To unprotect the whole chip it is necessary to protect all of the blocks first, then all blocks can be unprotected at the same time. To unprotect the chip follow [Figure 17: Programmer Equipment Chip Unprotect Flowchart](#). [Table 27: Programmer Technique Bus Operations, BYTE = VIH or VIL](#), gives a summary of each operation.

The timing on these flowcharts is critical. Care should be taken to ensure that, where a pause is specified, it is followed as closely as possible. Do not abort the procedure before reaching the end. Chip Unprotect can take several seconds and a user message should be provided to show that the operation is progressing.

C.2 In-System Technique

The In-System technique requires a high voltage level on the Reset/Blocks Temporary Unprotect pin, \overline{RP} . This can be achieved without violating the maximum ratings of the components on the microprocessor bus, therefore this technique is suitable for use after the Flash has been fitted to the system.

To protect a block follow the flowchart in [Figure 18: In-System Equipment Block Protect Flowchart](#). To unprotect the whole chip it is necessary to protect all of the blocks first, then all the blocks can be unprotected at the same time. To unprotect the chip follow [Figure 19: In-System Equipment Chip Unprotect Flowchart](#).

The timing on these flowcharts is critical. Care should be taken to ensure that, where a pause is specified, it is followed as closely as possible. Do not allow the microprocessor to service interrupts that will upset the timing and do not abort the procedure before reaching the end. Chip Unprotect can take several seconds and a user message should be provided to show that the operation is progressing.

Table 27. Programmer Technique Bus Operations, $\overline{\text{BYTE}} = V_{\text{IH}}$ or V_{IL}

Operation	$\overline{\text{E}}$	$\overline{\text{G}}$	$\overline{\text{W}}$	Address Inputs A0-A20	Data Inputs/Outputs DQ15A-1, DQ14-DQ0
Block Protect	V_{IL}	V_{ID}	V_{IL} Pulse	A9 = V_{ID} , A12-A20 Block Address Others = X	X
Chip Unprotect	V_{ID}	V_{ID}	V_{IL} Pulse	A9 = V_{ID} , A12 = V_{IH} , A15 = V_{IH} Others = X	X
Block Protection Verify	V_{IL}	V_{IL}	V_{IH}	A0 = V_{IL} , A1 = V_{IH} , A6 = V_{IL} , A9 = V_{ID} , A12-A20 Block Address Others = X	Pass = XX01h Retry = XX00h
Block Unprotection Verify	V_{IL}	V_{IL}	V_{IH}	A0 = V_{IL} , A1 = V_{IH} , A6 = V_{IH} , A9 = V_{ID} , A12-A20 Block Address Others = X	Retry = XX01h Pass = XX00h

Figure 16. Programmer Equipment Block Protect Flowchart

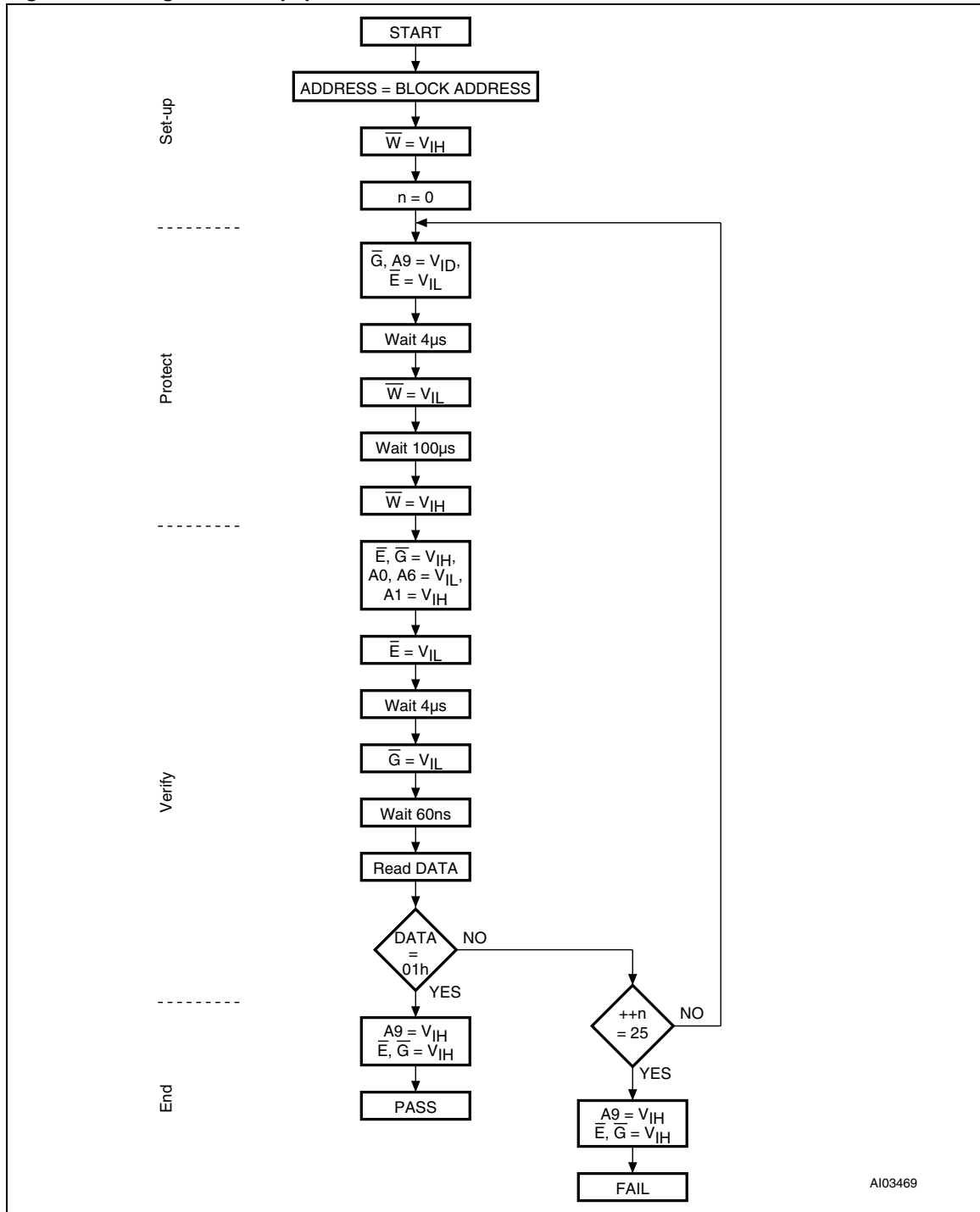

AI03469

Figure 17. Programmer Equipment Chip Unprotect Flowchart

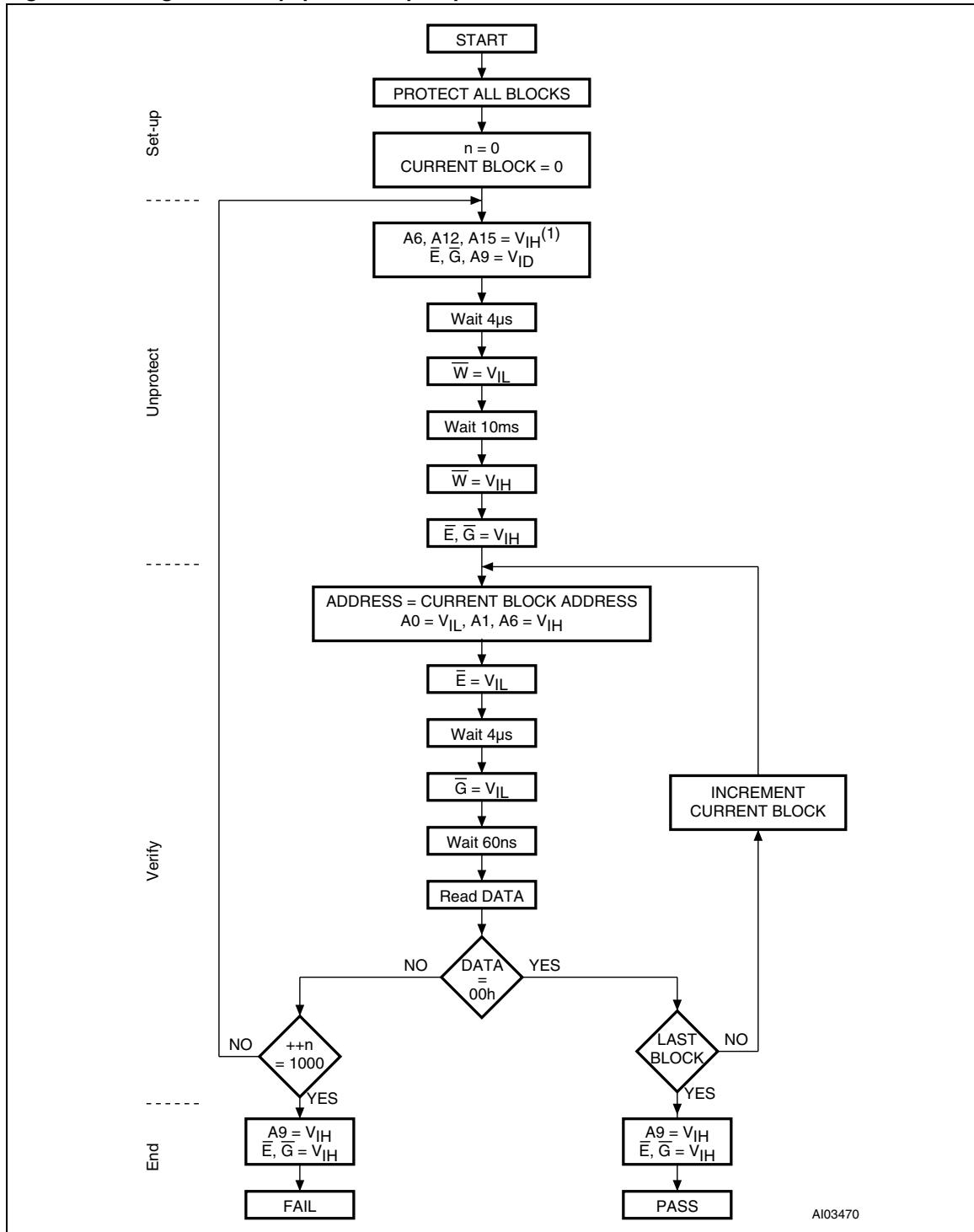

AI03470

Figure 18. In-System Equipment Block Protect Flowchart

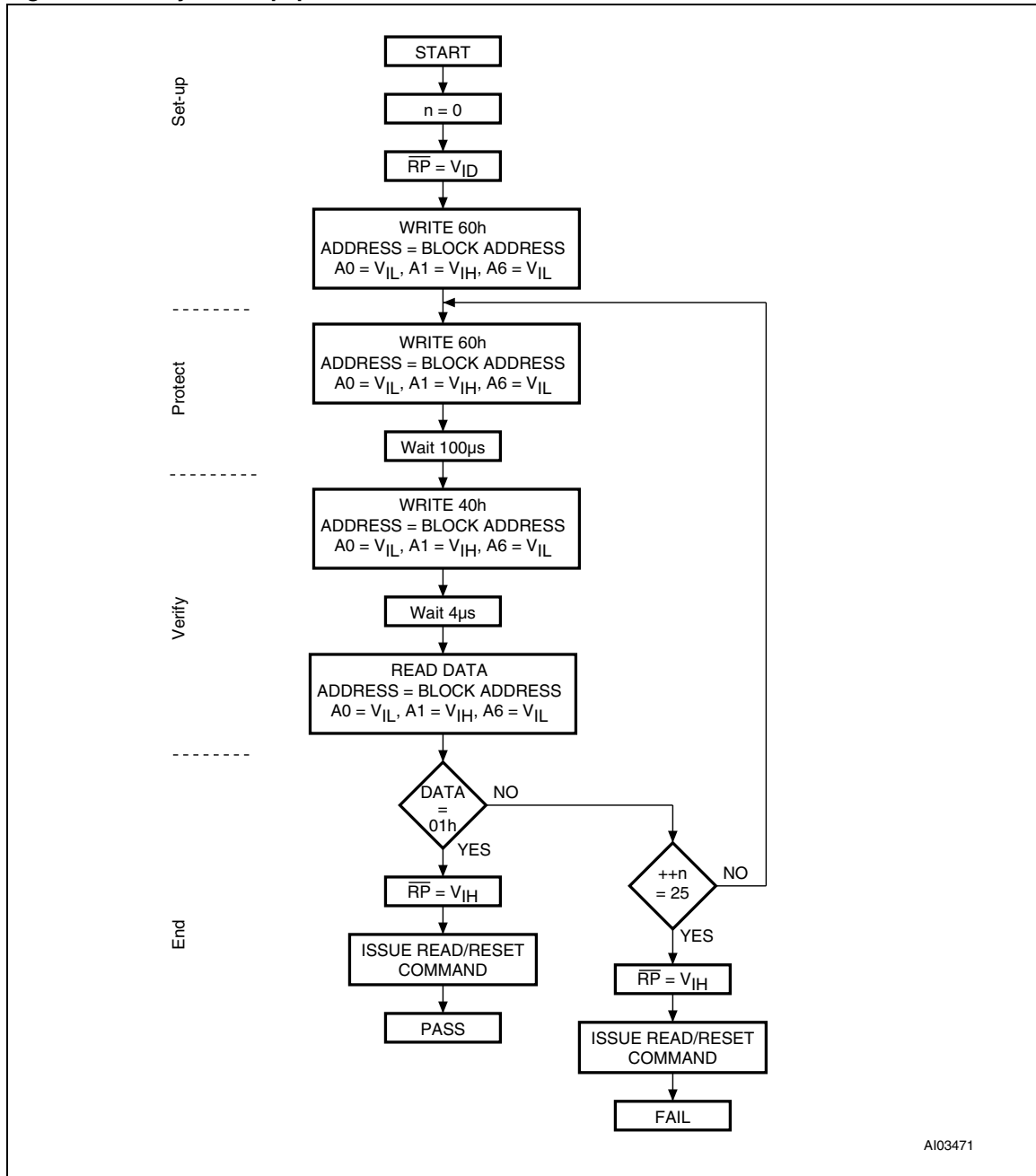

AI03471

Figure 19. In-System Equipment Chip Unprotect Flowchart

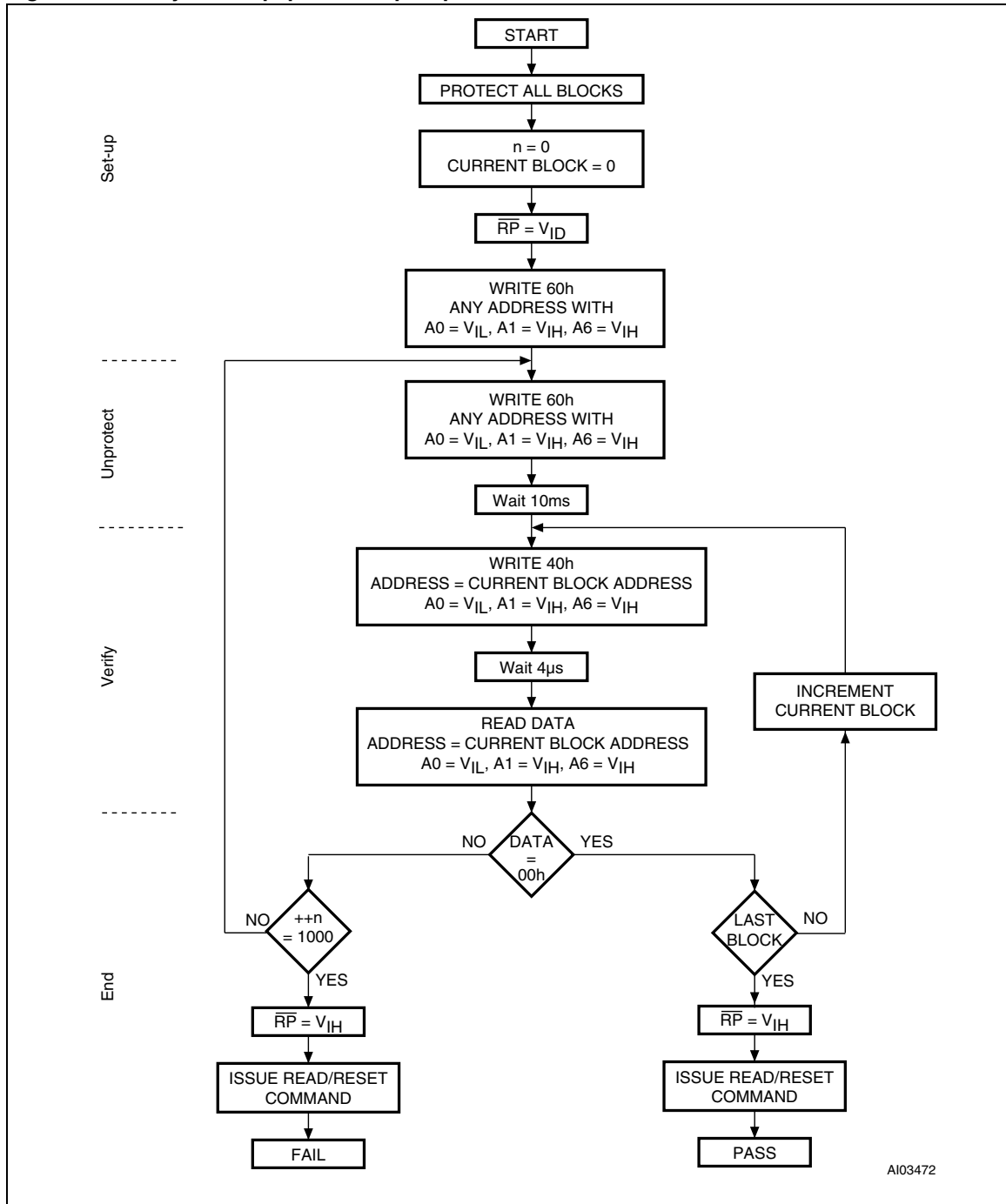

A103472

10 Revision history

Table 28. Document revision history

Date	Revision	Changes
March-2001	-01	First Issue (Brief Data)
08-Jun-2001	-02	Document expanded to full Product Preview
22-Jun-2001	-03	Minor text corrections to Read/Reset and Read CFI commands and Status Register Error and Toggle Bits.
27-Jul-2001	-04	Document type: from Product Preview to Preliminary Data TFBGA connections and Block Addresses (x16) diagrams clarification Write Protect and Block Unprotect clarification CFI Primary Algorithm table, Block Protection change
05-Oct-2001	-05	Added Block Protection Appendix "Write Protect/V _{PP} " pin renamed to "V _{PP} /Write Protect" to be consistent with abbreviation. Changes to the V _{PP} /W _P pin description, Figure 13 and Table 15 . I _{PP} added to Table 11 and I _{CC3} clarified. Modified description of V _{PP} /W _P operation in Unlock Bypass Command section. Added V _{PP} /W _P decoupling capacitor to Figure 1 . Clarified Read/Reset operation during Erase Suspend.
07-Feb-2002	-06	TFBGA package changed from 48 ball to 63 ball
05-Apr-2002	-07	Description of Ready/Busy signal clarified (and Figure 12 modified) Clarified allowable commands during block erase Clarified the mode the device returns to in the CFI Read Query command section
19-Nov-2002	7.1	Erase Suspend Latency Time (typical and maximum) added to Program, Erase Times and Program, Erase Endurance Cycles table. Typical values added for I _{cc1} and I _{cc2} in DC characteristics table. Logic Diagram and Data Toggle Flowchart corrected. Revision numbering modified: a minor revision will be indicated by incrementing the digit after the dot, and a major revision, by incrementing the digit before the dot (revision version 07 equals 7.0). Document promoted to full datasheet.
26-May-2003	7.2	Data Retention added to Table 6: Program, Erase Times and Program, Erase Endurance Cycles , and Typical after 100k W/E Cycles column removed. TSOP48 package mechanical updated. Lead-free package options E and F added to Table 18: Ordering Information Scheme .

Table 28. Document revision history (continued)

Date	Revision	Changes
16-Aug-2005	8.0	TFBGA48 package added throughout document.
13-Jun-2006	9	Document title modified. TFBGA63 package removed. ECOPACK text added. R \bar{B} signal updated in Figure 12: Reset/Block Temporary Unprotect AC Waveforms . t _{PLYH} updated in Table 15: Reset/Block Temporary Unprotect AC Characteristics . In Table 7: Status Register Bits , DQ7 changed to $\overline{DQ7}$ for Program, Program during Erase Suspend and Program Error.

Please Read Carefully:

Information in this document is provided solely in connection with ST products. STMicroelectronics NV and its subsidiaries ("ST") reserve the right to make changes, corrections, modifications or improvements, to this document, and the products and services described herein at any time, without notice.

All ST products are sold pursuant to ST's terms and conditions of sale.

Purchasers are solely responsible for the choice, selection and use of the ST products and services described herein, and ST assumes no liability whatsoever relating to the choice, selection or use of the ST products and services described herein.

No license, express or implied, by estoppel or otherwise, to any intellectual property rights is granted under this document. If any part of this document refers to any third party products or services it shall not be deemed a license grant by ST for the use of such third party products or services, or any intellectual property contained therein or considered as a warranty covering the use in any manner whatsoever of such third party products or services or any intellectual property contained therein.

UNLESS OTHERWISE SET FORTH IN ST'S TERMS AND CONDITIONS OF SALE ST DISCLAIMS ANY EXPRESS OR IMPLIED WARRANTY WITH RESPECT TO THE USE AND/OR SALE OF ST PRODUCTS INCLUDING WITHOUT LIMITATION IMPLIED WARRANTIES OF MERCHANTABILITY, FITNESS FOR A PARTICULAR PURPOSE (AND THEIR EQUIVALENTS UNDER THE LAWS OF ANY JURISDICTION), OR INFRINGEMENT OF ANY PATENT, COPYRIGHT OR OTHER INTELLECTUAL PROPERTY RIGHT.

UNLESS EXPRESSLY APPROVED IN WRITING BY AN AUTHORIZED REPRESENTATIVE OF ST, ST PRODUCTS ARE NOT DESIGNED, AUTHORIZED OR WARRANTED FOR USE IN MILITARY, AIR CRAFT, SPACE, LIFE SAVING, OR LIFE SUSTAINING APPLICATIONS, NOR IN PRODUCTS OR SYSTEMS, WHERE FAILURE OR MALFUNCTION MAY RESULT IN PERSONAL INJURY, DEATH, OR SEVERE PROPERTY OR ENVIRONMENTAL DAMAGE.

Resale of ST products with provisions different from the statements and/or technical features set forth in this document shall immediately void any warranty granted by ST for the ST product or service described herein and shall not create or extend in any manner whatsoever, any liability of ST.

ST and the ST logo are trademarks or registered trademarks of ST in various countries.

Information in this document supersedes and replaces all information previously supplied.

The ST logo is a registered trademark of STMicroelectronics. All other names are the property of their respective owners.

© 2006 STMicroelectronics - All rights reserved

STMicroelectronics group of companies

Australia - Belgium - Brazil - Canada - China - Czech Republic - Finland - France - Germany - Hong Kong - India - Israel - Italy - Japan - Malaysia - Malta - Morocco - Singapore - Spain - Sweden - Switzerland - United Kingdom - United States of America

www.st.com