

INTRODUCTION

The KS8803B/4B are designed to select 10/15 channels of cordless phone of which frequency band is 46/49MHz. It has reference frequency generator, programmable divider for transmit and receive section and phase detector.

FEATURES

- 10 Channels selectable : KS8803B (both transmit/receive)
- 15 Channels selectable : KS8804B (both transmit/receive)
- Include oscillation circuit with external x-tal (10.24MHz)
- 5KHz output for guard tone
- Unlock detector (phase difference more than 6.25us)
- Stand-by function for power saving

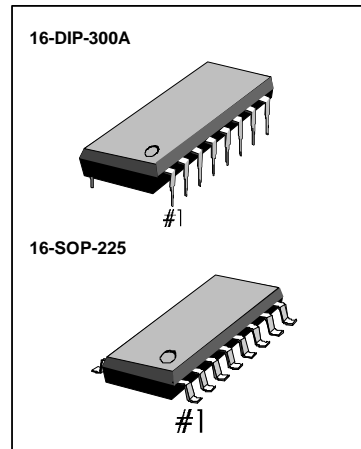

ORDERING INFORMATION

Device	Package	Operating Temperature
KS8803B	16-DIP-300A	- 30°C ~ + 75°C
KS8803BD	16-SOP-225	

BLOCK DIAGRAM

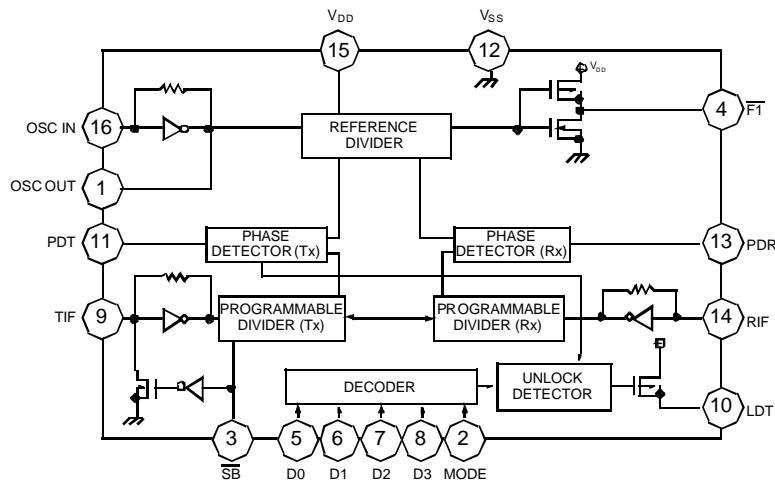

PIN CONFIGURATION

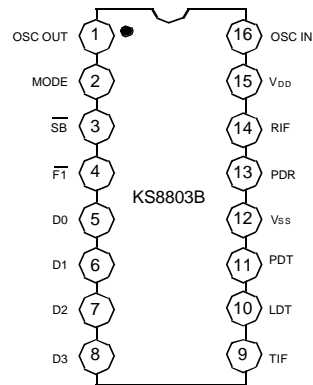

PIN DESCRIPTION

Pin No	Symbol	Description
1	OSC OUT	<ul style="list-style-type: none"> This output generates reference frequency when it is connected to Pin 16 with external OSC of which frequency is 10.24MHz
2	MODE	<ul style="list-style-type: none"> Base/Remote Unit Selection Pin "High" : Base Unit "Low" : Remote Unit
3	$\overline{\text{SB}}$	<ul style="list-style-type: none"> Stand-by pin This input controls Tx PLL for reducing the power dissipation "High" : Normal operation "Low" : Stand-by
4	$\overline{\text{F1}}$	<ul style="list-style-type: none"> 5KHz output
5	D0	<ul style="list-style-type: none"> Channel selection pins
6	D1	<ul style="list-style-type: none"> The Combinations of these inputs select one channel among the 10/15 channels
7	D2	
8	D3	
9	TIF	<ul style="list-style-type: none"> Input to programmable divider of Tx AC coupling with VCO In case of larger signal, It needs DC-coupling Min. input voltage is 0.1Vrms
10	LDT	<ul style="list-style-type: none"> Unlocked signal out pin (see output characteristics)

PIN DESCRIPTION

Pin No	Symbol	Description
11	PDT	<ul style="list-style-type: none"> Phase detector output for Tx PDT detects the phase error from Tx PLL and its output is connected to external low pass filter
12	V _{SS}	<ul style="list-style-type: none"> This pin is negative supply of the IC. It usually grounded
13	PDR	<ul style="list-style-type: none"> Phase detector output for Rx PDR detects the phase error from Rx PLL and its output is connected to external low pass filter
14	RIF	<ul style="list-style-type: none"> Input of programmable divider for Rx. AC coupling with VCO In case of lager signal (standard CMOS logic), it needs DC coupling Min. input voltage is 0.1Vrms
15	V _{DD}	<ul style="list-style-type: none"> This pin is positive supply of the IC Its reference is V_{SS}, and normally + 3.0V ~ + 5.5V more positive than V_{SS}
16	OSC IN	<ul style="list-style-type: none"> X-TAL osc connection pin This input generates the reference frequency when it is connected to pin 1 with external osc



ABSOLUTE MAXIMUM RATING ES (Ta = 25°C)

Characteristic	Symbol	Value	Unit
Supply voltage	V _{DD}	- 0.5 ~ 6.0	V
Input Voltage	V _I	- 0.3 ~ V _{DD} + 0.5	V
Power Dissipation	P _D	350	mW
Operating Temperature	T _{OPR}	- 30 ~ + 75	°C
Storage Temperature	T _{STG}	- 40 ~ + 125	°C

ELECTRICAL CHARACTERISTICS (Ta = 25°C, V_{DD} = 5V, unless otherwise specified)

Characterostoc	Symbol	Test Conditions	Min	Typ	Max	Unit
Supply Voltage	V _{DD}	-	3	-	5.5	V
Input Voltage	V _{IH1}	D0 - D3, \overline{SB}	0.7V _{DD}	-	V _{DD}	V
	V _{IL1}	D0 - D3, SB	-	-	0.3V _{DD}	V
	V _{IH2}	MODE	0.9V _{DD}	-	V _{DD}	V
	V _{IL2}	MODE	-	-	0.1V _{DD}	V
Input Frequency	f _{i1}	V _{TIF} = 0.15Vrms	10	-	52	MHz
	f _{i2}	V _{RIF} = 0.15Vrms	30	-	42	MHz
	f _{i3}	OSC _{IN} = 0.3Vrms	5	10.24	11	MHz
Input Amplitude	V _{I(AMP)1}	f _{TIF} = 52MHz	0.1	-	0.3V _{DD}	Vrms
	V _{I(AMP)2}	f _{RIF} = 42MHz	0.1	-	0.3V _{DD}	Vrms
	V _{I(AMP)3}	OSC _{IN} = 11MHz	0.3	-	0.3V _{DD}	Vrms
Input Current	I _{IH}	V _{IN} = V _{DD}	-	-	40	μA
	I _{IL}	V _{IN} = V _{SS}	-	-	40	μA



ELECTRICAL CHARACTERISTICS ($T_a = 25^\circ\text{C}$, $V_{DD} = 5\text{V}$, unless otherwise specified)

Characteristic	Symbol	Test Conditions	Min	Typ	Max	Unit
Output Voltage	V_{OH1}	PDT, RDR : $I_O = 0.5\text{mA}$	$V_{DD}-1.0$	-	-	V
	V_{OL1}	PDT, RDR : $I_O = 0.5\text{mA}$	-	-	1.0	V
	V_{OH2}	LDT : $I_O = 1\text{mA}$	$V_{DD}-1.0$	-	-	V
	V_{OL2}	$\overline{F1}$: $I_O = 1\text{mA}$	-	-	1.0	V
Output OFF Leakage Current	I_{LKG1}	PDT, PDR : $V_O = V_{DD}/V_{SS}$	-	0.01	1.0	μA
	I_{LKG2}	LDT : $V_O = V_{SS}$	-	-	5.0	μA
Stand-by Current	I_{SB1}	$V_{DD} = 3\text{V}$ (Note 2)	-	1.0	2.0	mA
	I_{SB2}	$V_{DD} = 3\text{V}$ (Note 2)	3.5	4.0	-	mA
Operating Current	I_{DD1}	$V_{DD} = 3\text{V}$ (Note 1)	-	2.0	3.0	mA
	I_{DD2}	$V_{DD} = 5\text{V}$ (Note 1)	-	6.0	7.0	mA

- NOTE 1) OSC_{IN} : 10.24MHz X-tal Connection
TIF : 27MHz 150mVrms
RIF : 42MHz 150mVrms
MODE : V_{DD} , SB = V_{DD} , others are opened
- NOTE 2) OSC_{IN} : 10.24MHz X-tal Connection
TIF : 27MHz 150mVrms
RIF : 42MHz 150mVrms
MODE : V_{DD} , SB = V_{SS} , others are opened
- Capacitor more than 2000pF should be connected between V_{DD} & V_{SS}



OUTPUT CHARACTERISTICS

1) LOCK

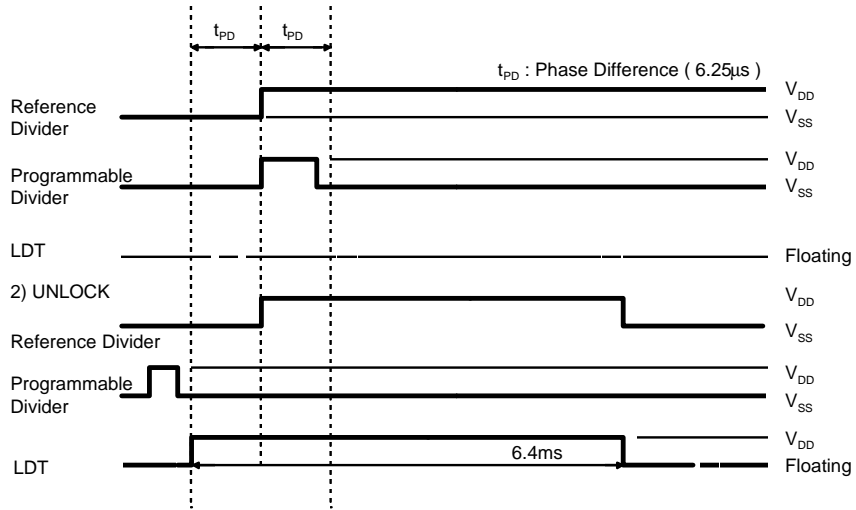

**TABLE 1. Channel & Frequency table to Base/Remote input data for KS8803B (10CH)
BASE (MODE = 1)**

INPUT					Rx (f _{REF} = 5KHz)			Tx (f _{REF} = 5KHz)		
D0	D1	D2	D3	CH	f _{RX} (MHz)	f _{VCO} (MHz)	N	f _{TX} (MHz)	f _{VCO} (MHz)	N
1	0	0	0	1	49.670	38.975	7795	46.610	46.610	9322
0	1	0	0	2	49.845	39.150	7830	46.630	46.630	9326
1	1	0	0	3	49.860	39.165	7833	46.670	46.670	9334
0	0	1	0	4	49.770	39.075	7815	46.710	46.710	9342
1	0	1	0	5	49.875	39.180	7836	46.730	46.730	9346
0	1	1	0	6	49.830	39.135	7827	46.770	46.770	9354
1	1	1	0	7	49.890	39.195	7839	46.830	46.830	9366
0	0	0	1	8	49.930	39.235	7847	46.870	46.870	9374
1	0	0	1	9	49.990	39.295	7859	46.930	46.930	9386
0	1	0	1	10	49.970	39.275	7855	46.970	46.970	9394
1	1	0	1	10	49.970	39.275	7855	46.970	46.970	9394
0	0	1	1	10	49.970	39.275	7855	46.970	46.970	9394
1	0	1	1	10	49.970	39.275	7855	46.970	46.970	9394
0	1	1	1	10	49.970	39.275	7855	46.970	46.970	9394
1	1	1	1	10	49.970	39.275	7855	46.970	46.970	9394
0	0	0	0	10	49.970	39.275	7855	46.970	46.970	9394

REMOTE (MODE = 0)

INPUT					Rx (f _{REF} = 5KHz)			Tx (f _{REF} = 5KHz)		
D0	D1	D2	D3	CH	f _{RX} (MHz)	f _{VCO} (MHz)	N	f _{RX} (MHz)	f _{VCO} (MHz)	N
1	0	0	0	1	46.610	35.915	7183	49.670	49.670	9934
0	1	0	0	2	46.630	35.935	7187	49.845	49.845	9969
1	1	0	0	3	46.670	35.975	7195	49.860	49.860	9972
0	0	1	0	4	46.710	36.015	7203	49.770	49.770	9954
1	0	1	0	5	46.730	36.035	7207	49.875	49.875	9975
0	1	1	0	6	46.770	36.075	7215	49.830	49.830	9966
1	1	1	0	7	46.830	36.135	7227	49.890	49.890	9978
0	0	0	1	8	46.870	36.175	7235	49.930	49.930	9986
1	0	0	1	9	46.930	36.235	7247	49.990	49.990	9998
0	1	0	1	10	46.970	36.275	7255	49.970	49.970	9994
1	1	0	1	10	46.970	36.275	7555	49.970	49.970	9994
0	0	1	1	10	46.970	36.275	7255	49.970	49.970	9994
1	0	1	1	10	46.970	36.275	7255	49.970	49.970	9994
0	1	1	1	10	46.970	36.275	7255	49.970	49.970	9994
1	1	1	1	10	46.970	36.275	7255	49.970	49.970	9994
0	0	0	0	10	46.970	36.275	7255	49.970	49.970	9994



**TABLE 2. Channel & Frequency table to Base/Remote input data for KS8804B (15CH)
BASE (MODE = 1)**

INPUT					Rx (f _{REF} = 5KHz)			Tx (f _{REF} = 5KHz)		
D0	D1	D2	D3	CH	f _{RX} (MHz)	f _{VCO} (MHz)	N	f _{TX} (MHz)	f _{VCO} (MHz)	N
1	0	0	0	1	49.695	39.000	7800	46.510	46.510	9302
0	1	0	0	2	49.710	39.015	7803	46.530	46.530	9306
1	1	0	0	3	49.725	39.030	7806	46.550	46.550	9310
0	0	1	0	4	49.740	39.045	7809	46.570	46.570	9314
1	0	1	0	5	49.755	39.060	7812	46.590	46.590	9318
0	1	1	0	6	49.670	38.975	7795	46.610	46.610	9322
1	1	1	0	7	49.845	39.150	7830	46.630	46.630	9326
0	0	0	1	8	49.860	39.165	7833	46.670	46.670	9334
1	0	0	1	9	49.770	39.075	7815	46.710	46.710	9342
0	1	0	1	10	49.875	39.180	7836	46.730	46.730	9346
1	1	0	1	11	49.830	39.135	7827	46.770	46.770	9354
0	0	1	1	12	49.890	39.195	7839	46.830	46.830	9366
1	0	1	1	13	49.930	39.235	7847	46.870	46.870	9374
0	1	1	1	14	49.990	39.295	7859	46.930	46.930	9386
1	1	1	1	15	49.970	39.275	7855	46.970	46.970	9394
0	0	0	0	15	49.970	39.275	7855	46.970	46.970	9394

REMOTE (MODE = 0)

INPUT					Rx (f _{REF} = 5KHz)			Tx (f _{REF} = 5KHz)		
D0	D1	D2	D3	CH	f _{RX} (MHz)	f _{VCO} (MHz)	N	f _{RX} (MHz)	f _{VCO} (MHz)	N
1	0	0	0	1	46.510	35.815	7163	49.695	49.695	9939
0	1	0	0	2	46.530	35.835	7167	49.710	49.710	9942
1	1	0	0	3	46.550	35.855	7171	49.725	49.725	9945
0	0	1	0	4	46.570	35.875	7175	49.740	49.740	9948
1	0	1	0	5	46.590	35.895	7179	49.755	49.755	9951
0	1	1	0	6	46.610	35.915	7183	49.670	49.670	9934
1	1	1	0	7	46.630	35.935	7187	49.845	49.845	9969
0	0	0	1	8	46.670	35.975	7195	49.860	49.860	9972
1	0	0	1	9	46.710	36.015	7203	49.770	49.770	9954
0	1	0	1	10	46.730	36.035	7207	49.875	49.875	9975
1	1	0	1	11	46.770	36.075	7215	49.830	49.830	9966
0	0	1	1	12	46.830	36.135	7227	49.890	49.890	9978
1	0	1	1	13	46.870	36.175	7235	49.930	49.930	9986
0	1	1	1	14	46.930	36.235	7247	49.990	49.990	9998
1	1	1	1	15	46.970	36.275	7255	49.970	49.970	9994
0	0	0	0	15	46.970	36.275	7255	49.970	49.970	9994



APPLICATION CIRCUIT

