

# PC400

## Compact, Surface Mount Type OPIC Photocoupler

### ■ Features

1. Mini-flat package
2. "Low" output during light emission
3. Isolation voltage between input and output  
( $V_{iso} : 3\,750V_{rms}$ )
4. TTL and LSTTL compatible output
5. Recognized by UL(No.E64380)

### ■ Applications

1. Hybrid substrate which requires high density mounting
2. Personal computers, office computers and peripheral equipment
3. Electronic musical instruments

### ■ Outline Dimensions

( Unit : mm )

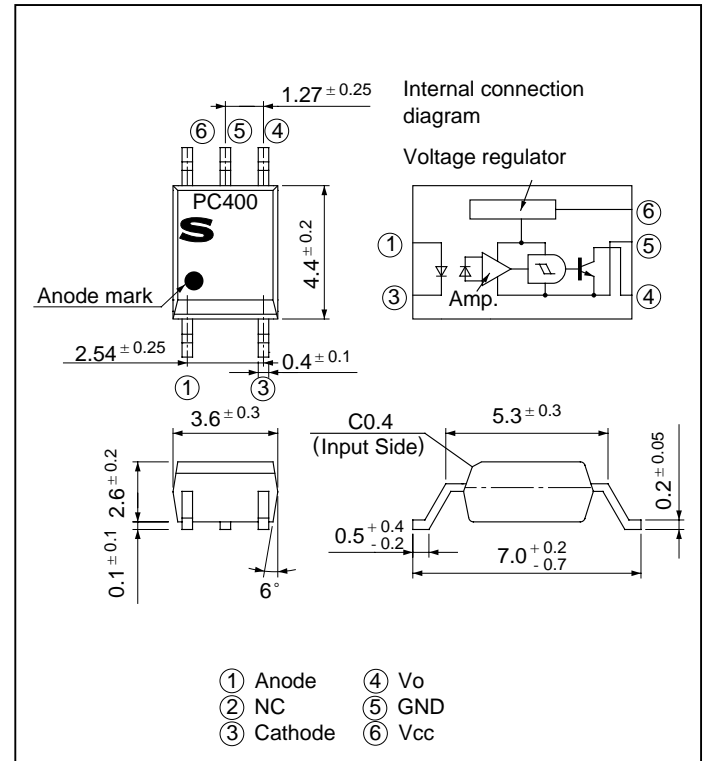

### ■ Package Specifications

Model No.	Package specifications	Diameter of reel	Tape width
PC400	Taping package (Net:3 000pcs. )	φ 370mm	12mm
PC400T	Taping package (Net: 750pcs. )	φ 178mm	12mm
PC400Z	Sleeve package (Net: 100pcs. )	-	-

### ■ Absolute Maximum Ratings

( $T_a = 25^\circ C$ )

	Parameter	Symbol	Rating	Unit
Input	Forward current	$I_F$	50	mA
	Reverse voltage	$V_R$	6	V
	Power dissipation	$P$	70	mW
Output	Supply voltage	$V_{CC}$	16	V
	High level output voltage	$V_{OH}$	16	V
	Low level output current	$I_{OL}$	50	mA
	Power dissipation	$P_O$	130	mW
	Total power dissipation	$P_{tot}$	150	mW
	*1 Isolation voltage	$V_{iso}$	3 750	$V_{rms}$
	Operating temperature	$T_{opr}$	- 25 to + 85	$^\circ C$
	Storage temperature	$T_{stg}$	- 40 to + 125	$^\circ C$
	*2 Soldering temperature	$T_{sol}$	260	$^\circ C$

\*1 AC for 1 minute, 40 to 60% RH

\*2 For 10 seconds

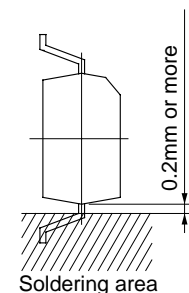

## Electro-optical Characteristics

( $T_a = 0$  to  $+70^\circ\text{C}$  unless otherwise specified)

Parameter		Symbol	Conditions	MIN.	TYP.	MAX.	Unit
Input	Forward voltage	$V_F$	$I_F = 4\text{mA}$	-	1.1	1.4	V
			$I_F = 0.3\text{mA}$	0.7	1.0	-	
	Reverse current	$I_R$	$T_a = 25^\circ\text{C}, V_R = 3\text{V}$	-	-	10	$\mu\text{A}$
	Terminal capacitance	$C_t$	$T_a = 25^\circ\text{C}, V = 0$ $f = 1\text{kHz}$	-	30	250	pF
Output	Operating supply voltage	$V_{CC}$		3	-	15	V
	Low level output voltage	$V_{OL}$	$I_{OL} = 16\text{mA}, V_{CC} = 5\text{V}$ $I_F = 4\text{mA}$	-	0.2	0.4	V
	High level output current	$I_{OH}$	$V_{CC} = V_O = 15\text{V}, I_F = 0$	-	-	100	$\mu\text{A}$
	Low level supply current	$I_{CCL}$	$V_{CC} = 5\text{V}, I_F = 4\text{mA}$	-	2.5	5.0	mA
	High level supply current	$I_{CCH}$	$V_{CC} = 5\text{V}, I_F = 0$	-	1.0	5.0	mA
Transfer characteristics	*3 "H→L" threshold input current	$I_{FHL}$	$T_a = 25^\circ\text{C}, V_{CC} = 5\text{V}$ $R_L = 280\Omega$	-	1.1	2.0	mA
			$V_{CC} = 5\text{V}, R_L = 280\Omega$	-	-	4.0	
	*4 "L→H" threshold input current	$I_{FLH}$	$T_a = 25^\circ\text{C}, V_{CC} = 5\text{V}$ $R_L = 280\Omega$	0.4	0.8	-	mA
			$V_{CC} = 5\text{V}, R_L = 280\Omega$	0.3	-	-	
	*5 Hysteresis	$I_{FLH} / I_{FHL}$	$V_{CC} = 5\text{V}, R_L = 280\Omega$	0.5	0.7	0.9	
	Isolation resistance	$R_{ISO}$	$T_a = 25^\circ\text{C}, \text{DC500V}$ 40 to 60% RH	$5 \times 10^{10}$	$10^{11}$	-	$\Omega$
	*6 Response time	"H→L" propagation delay time	$t_{PHL}$	$T_a = 25^\circ\text{C}$  $V_{CC} = 5\text{V}, I_F = 4\text{mA}$  $R_L = 280\Omega$	-	1	3
"L→H" propagation delay time		$t_{PLH}$	-		2	6	
Fall time		$t_f$	-		0.05	0.5	
Rise time		$t_r$	-		0.1	0.5	

\*3  $I_{FHL}$  represents forward current when output goes from high to low.

\*4  $I_{FLH}$  represents forward current when output goes from low to high.

\*5 Hysteresis stands for  $I_{FLH} / I_{FHL}$ .

\*6 Test circuit for response time is shown below.

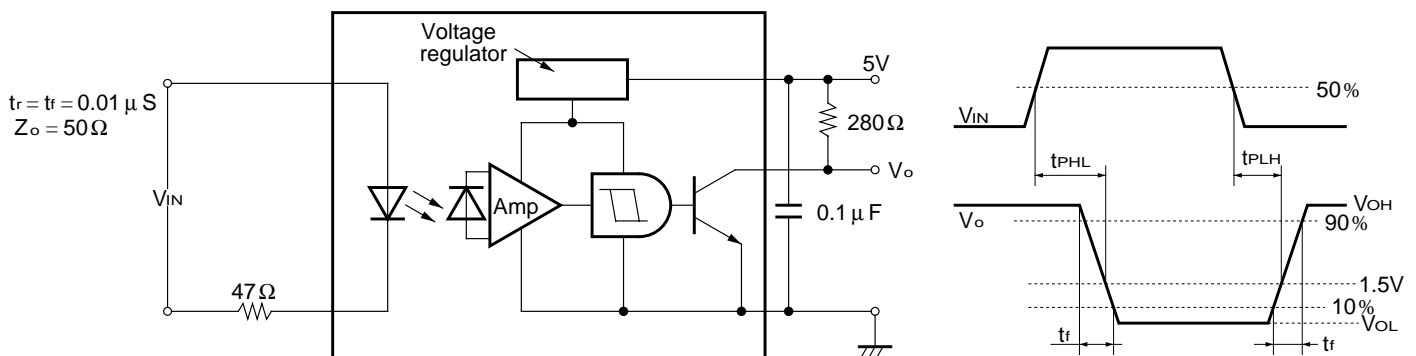

**Fig. 1 Forward Current vs. Ambient Temperature**

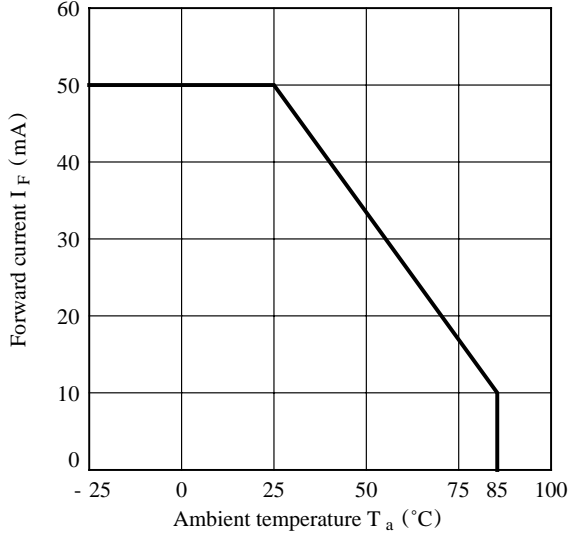

**Fig. 2 Power Dissipation vs. Ambient Temperature**

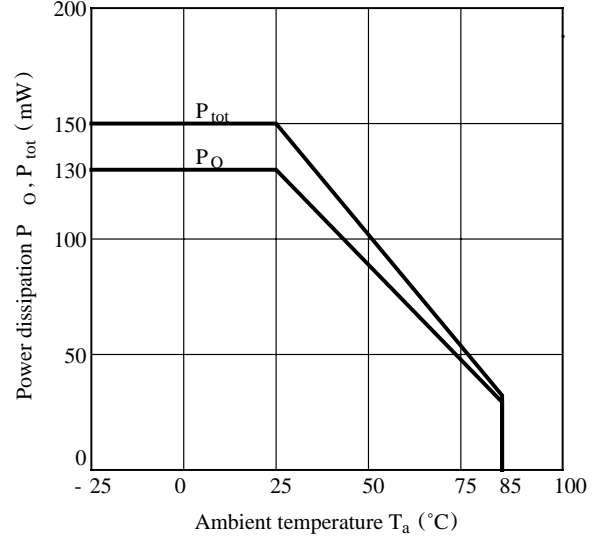

**Fig. 3 Forward Current vs. Forward Voltage**

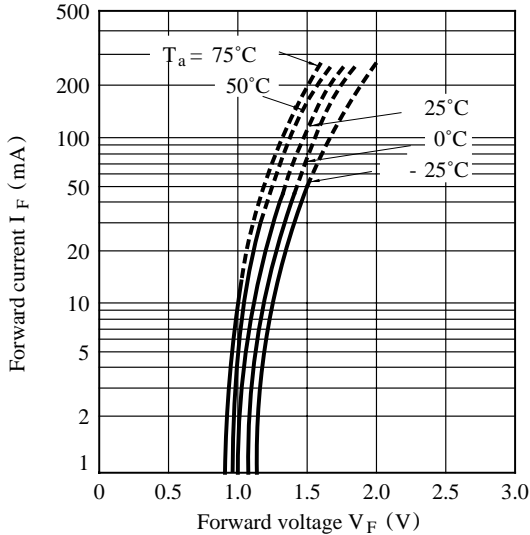

**Fig. 4 Relative Threshold Input Current vs. Supply Voltage**

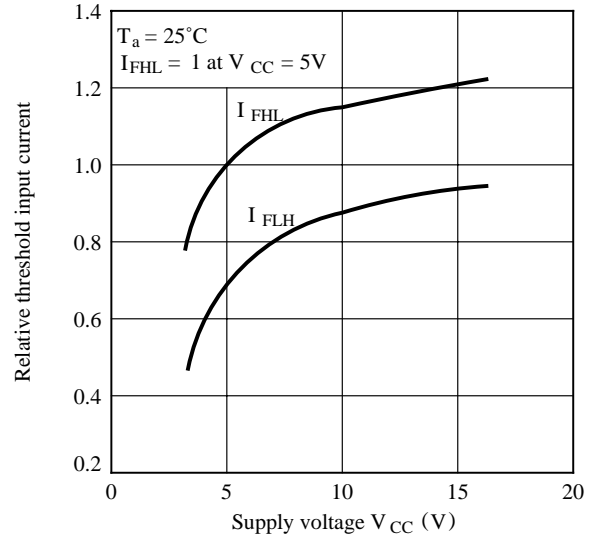

**Fig. 5 Relative Threshold Input Current vs. Ambient Temperature**

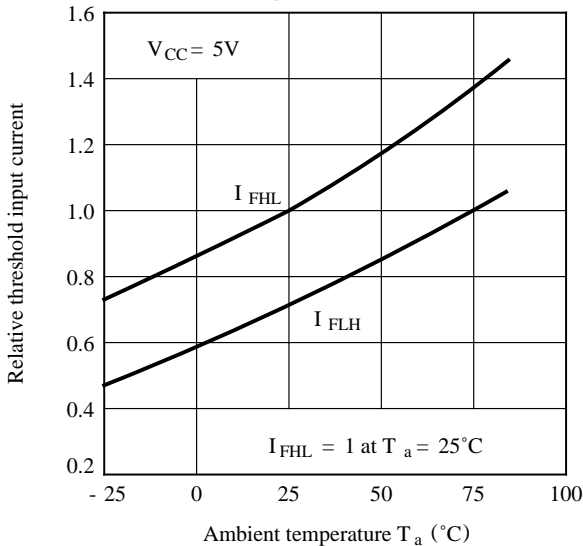

**Fig. 6 Low Level Output Voltage vs. Low Level Output Current**

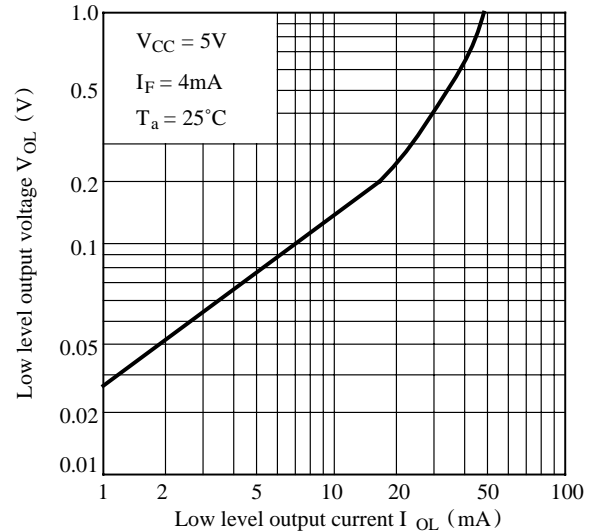

**Fig. 7 Low Level Output Voltage vs. Ambient Temperature**

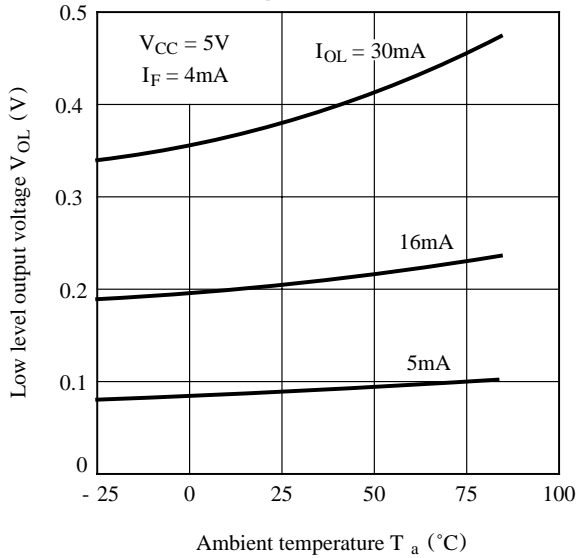

**Fig. 9 Propagation Delay Time vs. Forward Current**

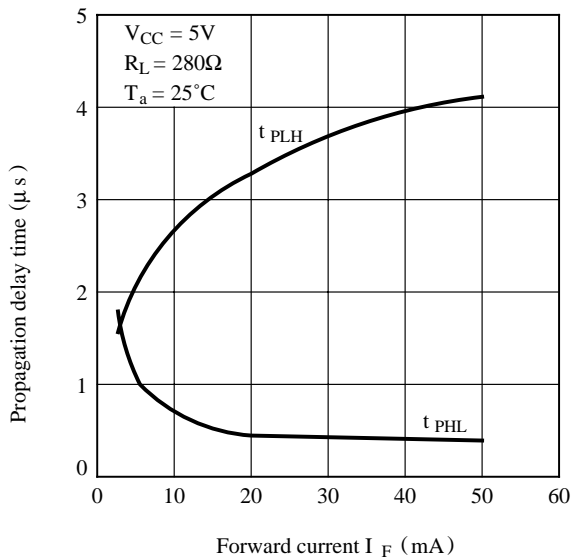

**Fig. 8 Supply Current vs. Supply Voltage**

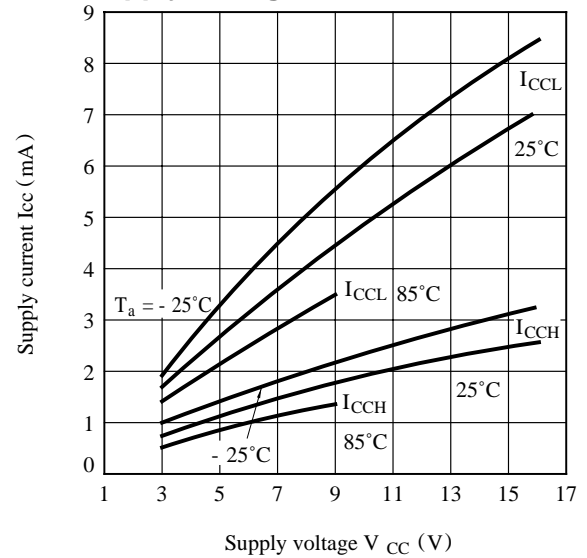

**Fig.10 Rise Time, Fall Time vs. Load Resistance**

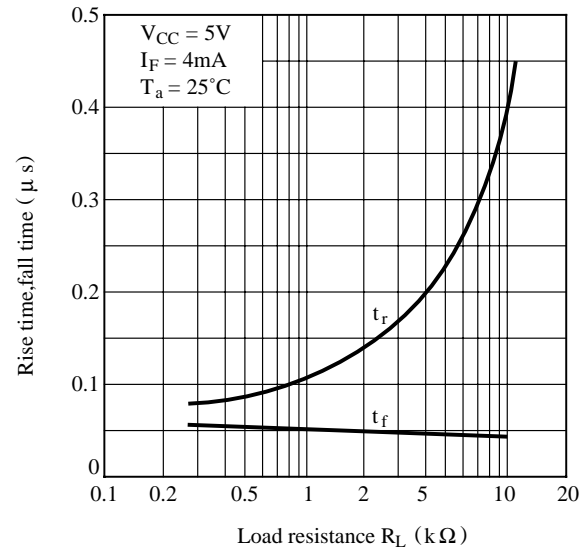

## ■ Precautions for Use

- (1) It is recommended that a by-pass capacitor of more than  $0.01 \mu\text{F}$  be added between  $V_{CC}$  and GND near the device in order to stabilize power supply line.
- (2) Handle this product the same as with other integrated circuits against static electricity.
- (3) As for other general cautions, refer to the chapter "Precautions for Use"