

AD7816/AD7817/AD7818

FEATURES

10-Bit ADC with 9 μ s Conversion Time
One (AD7818) and Four (AD7817) Single-Ended Analog Input Channels

The AD7816 Is a Temperature Measurement Only Device
On-Chip Temperature Sensor

Resolution of 0.25°C

$\pm 2^\circ\text{C}$ Error from -40°C to $+85^\circ\text{C}$

-55°C to $+125^\circ\text{C}$ Operating Range

Wide Operating Supply Range

2.7 V to 5.5 V

Inherent Track-and-Hold Functionality

On-Chip Reference (2.5 V \pm 1%)

Overtemperature Indicator

Automatic Power-Down at the End of a Conversion

Low Power Operation

4 μ W at a Throughput Rate of 10 SPS

40 μ W at a Throughput Rate of 1 kSPS

400 μ W at a Throughput Rate of 10 kSPS

Flexible Serial Interface

APPLICATIONS

Ambient Temperature Monitoring (AD7816)

Thermostat and Fan Control

High Speed Microprocessor

Temperature Measurement and Control

Data Acquisition Systems with Ambient Temperature Monitoring (AD7817 and AD7818)

Industrial Process Control

Automotive

Battery Charging Applications

GENERAL DESCRIPTION

The AD7818 and AD7817 are 10-bit, single- and 4-channel A/D converters with on-chip temperature sensor that can operate from a single 2.7 V to 5.5 V power supply. Each part contains a 9 μ s successive-approximation converter based around a capacitor DAC, an on-chip temperature sensor with an accuracy of $\pm 2^\circ\text{C}$, an on-chip clock oscillator, inherent track-and-hold functionality and an on-chip reference (2.5 V). The AD7816 is a temperature monitoring only device in a SOIC/MSOP package.

The on-chip temperature sensor of the AD7817 and AD7818 can be accessed via Channel 0. When Channel 0 is selected and a conversion is initiated, the resulting ADC code at the end of the conversion gives a measurement of the ambient temperature with a resolution of $\pm 0.25^\circ\text{C}$. See Temperature Measurement section of this data sheet.

REV. C

Information furnished by Analog Devices is believed to be accurate and reliable. However, no responsibility is assumed by Analog Devices for its use, nor for any infringements of patents or other rights of third parties that may result from its use. No license is granted by implication or otherwise under any patent or patent rights of Analog Devices. Trademarks and registered trademarks are the property of their respective owners.

FUNCTIONAL BLOCK DIAGRAM

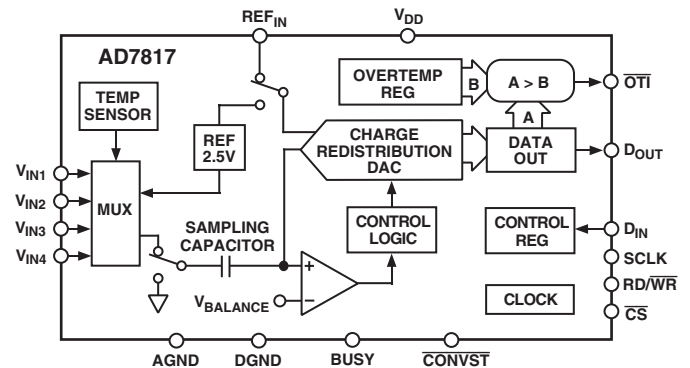

The AD7816, AD7817, and AD7818 have a flexible serial interface that allows easy interfacing to most microcontrollers. The interface is compatible with the Intel 8051, Motorola SPI[®] and QSPI[™] protocols and National Semiconductors MICROWIRE[™] protocol. For more information refer to the Serial Interface section of this data sheet.

The AD7817 is available in a narrow body 0.15" 16-lead small outline IC (SOIC), in a 16-lead, thin shrink small outline package (TSSOP), while the AD7816/AD7818 come in an 8-lead small outline IC (SOIC) and an 8-lead microsmall outline IC (MSOP).

PRODUCT HIGHLIGHTS

1. The devices have an on-chip temperature sensor that allows an accurate measurement of the ambient temperature to be made. The measurable temperature range is -55°C to $+125^\circ\text{C}$.
2. An overtemperature indicator is implemented by carrying out a digital comparison of the ADC code for Channel 0 (temperature sensor) with the contents of the on-chip overtemperature register. The overtemperature indicator pin goes logic low when a predetermined temperature is exceeded.
3. The automatic power-down feature enables the AD7816, AD7817, and AD7818 to achieve superior power performance at slower throughput rates, e.g., 40 μ W at 1 kSPS throughput rate.

AD7816/AD7817/AD7818

AD7817—SPECIFICATIONS¹ ($V_{DD} = 2.7\text{ V to }5.5\text{ V}$, $GND = 0\text{ V}$, $REF_{IN} = 2.5\text{ V}$ unless otherwise noted)

Parameter	A Version	*B Version	*S Version	Unit	Test Conditions/Comments
DYNAMIC PERFORMANCE					
Signal to (Noise + Distortion) Ratio ²	58	58	58	dB min	Sample Rate = 100 kSPS, Any Channel, $f_{IN} = 20\text{ kHz}$ -75 dB typ -75 dB typ $f_a = 19.9\text{ kHz}$, $f_b = 20.1\text{ kHz}$ $f_{IN} = 20\text{ kHz}$
Total Harmonic Distortion ²	-65	-65	-65	dB max	
Peak Harmonic or Spurious Noise ²	-65	-65	-65	dB max	
Intermodulation Distortion ²					
Second Order Terms	-67	-67	-67	dB typ	
Third Order Terms	-67	-67	-67	dB typ	
Channel-to-Channel Isolation ²	-80	-80	-80	dB typ	
DC ACCURACY					
Resolution	10	10	10	Bits	Any Channel
Minimum Resolution for Which No Missing Codes are Guaranteed	10	10	10	Bits	
Relative Accuracy ²	±1	±1	±1	LSB max	External Reference Internal Reference
Differential Nonlinearity ²	±1	±1	±1	LSB max	
Gain Error ²	±2	±2	±2	LSB max	
	±10	±10	+20/-10	LSB max	
Gain Error Match ²	±1/2	±1/2	±1/2	LSB max	
Offset Error ²	±2	±2	±2	LSB max	
Offset Error Match	±1/2	±1/2	±1/2	LSB max	
TEMPERATURE SENSOR¹					
Measurement Error					External Reference $V_{REF} = 2.5\text{ V}$
Ambient Temperature 25°C	±2	±1	±2	°C max	
T_{MIN} to T_{MAX}	±3	±2	±3	°C max	On-Chip Reference
Measurement Error					
Ambient Temperature 25°C	±2.25	±2.25	±2.25	°C max	
T_{MIN} to T_{MAX}	±3	±3	±6	°C max	
Temperature Resolution	1/4	1/4	1/4	°C/LSB	
REFERENCE INPUT^{3, 4}					
REF _{IN} Input Voltage Range ³	2.625 2.375	2.625 2.375	2.625 2.375	V max V min	2.5 V + 5% 2.5 V - 5%
Input Impedance	40	40	40	kΩ min	
Input Capacitance	10	10	10	pF max	
ON-CHIP REFERENCE⁵					
Temperature Coefficient ³	80	80	150	ppm/°C typ	Nominal 2.5 V
CONVERSION RATE					
Track/Hold Acquisition Time ⁴	400	400	400	ns max	Source Impedance < 10 Ω
Conversion Time					
Temperature Sensor	27	27	27	μs max	
Channels 1 to 4	9	9	9	μs max	
POWER REQUIREMENTS					
V_{DD}	5.5 2.7	5.5 2.7	5.5 2.7	V max V min	For Specified Performance
I_{DD}					
Normal Operation	2	2	2	mA max	Logic Inputs = 0 V or V_{DD} 1.6 mA typ
Using External Reference	1.75	1.75	1.75	mA max	
Power-Down ($V_{DD} = 5\text{ V}$)	10	10	12.5	μA max	2.5 V External Reference Connected 5.5 μA typ
Power-Down ($V_{DD} = 3\text{ V}$)	4	4	4.5	μA max	
Auto Power-Down Mode					2 μA typ $V_{DD} = 3\text{ V}$
10 SPS Throughput Rate	6.4	6.4	6.4	μW typ	See Power vs. Throughput Section for Description of Power Dissipation in Auto Power-Down Mode
1 kSPS Throughput Rate	48.8	48.8	48.8	μW typ	
10 kSPS Throughput Rate	434	434	434	μW typ	
Power-Down	12	12	13.5	μW max	
Typically 6 μW					

AD7816/AD7818⁶—SPECIFICATIONS¹ ($V_{DD} = 2.7\text{ V to }5.5\text{ V}$, $GND = 0\text{ V}$, $REF_{IN} = 2.5\text{ V}$ unless otherwise noted)

Parameter	A Version	Unit	Test Conditions/Comments
DYNAMIC PERFORMANCE (AD7818 Only)			
Signal to (Noise + Distortion) Ratio ²	57	dB min	Sample Rate = 100 kSPS, Any Channel, $f_{IN} = 20\text{ kHz}$
Total Harmonic Distortion ²	-65	dB max	-75 dB typ
Peak Harmonic or Spurious Noise ²	-67	dB typ	-75 dB typ
Intermodulation Distortion ²			$f_a = 19.9\text{ kHz}$, $f_b = 20.1\text{ kHz}$
Second Order Terms	-67	dB typ	
Third Order Terms	-67	dB typ	
Channel-to-Channel Isolation ²	-80	dB typ	$f_{IN} = 20\text{ kHz}$
DC ACCURACY (AD7818 Only)			
Resolution	10	Bits	Any Channel
Minimum Resolution for Which No Missing Codes are Guaranteed	10	Bits	
Relative Accuracy ²	± 1	LSB max	
Differential Nonlinearity ²	± 1	LSB max	
Gain Error ²	± 10	LSB max	
Offset Error ²	± 4	LSB max	
TEMPERATURE SENSOR¹			
Measurement Error			External Reference $V_{REF} = 2.5\text{ V}$
Ambient Temperature 25°C	± 2	°C max	
T_{MIN} to T_{MAX}	± 3	°C max	
Measurement Error			On-Chip Reference
Ambient Temperature 25°C	± 2	°C max	
T_{MIN} to T_{MAX}	± 3	°C max	
Temperature Resolution	1/4	°C/LSB	
REFERENCE INPUT^{3, 4} (AD7816 Only)			
REF_{IN} Input Voltage Range ³	2.625 2.375	V max V min	2.5 V + 5% 2.5 V - 5%
Input Impedance	50	k Ω min	
Input Capacitance	10	pF max	
ON-CHIP REFERENCE⁵			
Temperature Coefficient ³	30	ppm/°C typ	Nominal 2.5 V
CONVERSION RATE			
Track/Hold Acquisition Time ⁴	400	ns max	Source Impedance < 10 Ω
Conversion Time			
Temperature Sensor	27	μs max	
Channel 1	9	μs max	(AD7818 Only)
POWER REQUIREMENTS			
V_{DD}	5.5 2.7	V max V min	For Specified Performance
I_{DD}			Logic Inputs = 0 V or V_{DD}
Normal Operation	2	mA max	1.3 mA typ
Using External Reference	1.75	mA max	2.5 V External Reference Connected
Power-Down ($V_{DD} = 5\text{ V}$)	10.75	μA max	6 μA typ
Power-Down ($V_{DD} = 3\text{ V}$)	4.5	μA max	2 μA typ
Auto Power-Down Mode			$V_{DD} = 3\text{ V}$
10 SPS Throughput Rate	6.4	μW typ	See Power vs. Throughput Section for
1 kSPS Throughput Rate	48.8	μW typ	Description of Power Dissipation in
10 kSPS Throughput Rate	434	μW typ	Auto Power-Down Mode
Power-Down	13.5	μW max	Typically 6 μW

AD7816/AD7817/AD7818—SPECIFICATIONS

Parameter	A Version	*B Version	*S Version	Unit	Test Conditions/Comments
ANALOG INPUTS⁷					
Input Voltage Range	V_{REF} 0	V_{REF} 0	V_{REF} 0	V max V min	(AD7817 and AD7818)
Input Leakage	± 1	± 1	± 1	μA min	
Input Capacitance	10	10	10	pF max	
LOGIC INPUTS⁴					
Input High Voltage, V_{INH}	2.4	2.4	2.4	V min	$V_{DD} = 5\text{ V} \pm 10\%$
Input Low Voltage, V_{INL}	0.8	0.8	0.8	V max	$V_{DD} = 5\text{ V} \pm 10\%$
Input High Voltage, V_{INH}	2	2	2	V min	$V_{DD} = 3\text{ V} \pm 10\%$
Input Low Voltage, V_{INL}	0.4	0.4	0.4	V max	$V_{DD} = 3\text{ V} \pm 10\%$
Input Current, I_{IN}	± 3	± 3	± 3	μA max	Typically 10 nA, $V_{IN} = 0\text{ V}$ to V_{DD}
Input Capacitance, C_{IN}	10	10	10	pF max	
LOGIC OUTPUTS⁴					
Output High Voltage, V_{OH}	4 2.4	4 2.4	4 2.4	V min V min	$I_{SOURCE} = 200\ \mu\text{A}$ $V_{DD} = 5\text{ V} \pm 10\%$ $V_{DD} = 3\text{ V} \pm 10\%$
Output Low Voltage, V_{OL}	0.4 0.2	0.4 0.2	0.4 0.2	V max V max	$I_{SINK} = 200\ \mu\text{A}$ $V_{DD} = 5\text{ V} \pm 10\%$ $V_{DD} = 3\text{ V} \pm 10\%$
High Impedance Leakage Current	± 1	± 1	± 1	μA max	
High Impedance Capacitance	15	15	15	pF max	

NOTES

*B and S Versions apply to AD7817 only. For operating temperature ranges, see Ordering Guide.

¹AD7816 and AD7817 temperature sensors specified with external 2.5 V reference, AD7818 specified with on-chip reference. All other specifications with external and on-chip reference (2.5 V). For $V_{DD} = 2.7\text{ V}$, $T_A = 85^\circ\text{C}$ max and temperature sensor measurement error = $\pm 3^\circ\text{C}$.

²See Terminology.

³The accuracy of the temperature sensor is affected by reference tolerance. The relationship between the two is explained in the section titled Temperature Measurement Error Due to Reference Error.

⁴Sample tested during initial release and after any redesign or process change that may affect this parameter.

⁵On-chip reference shuts down when external reference is applied.

⁶All specifications are typical for AD7818 at temperatures above 85°C and with V_{DD} greater than 3.6 V.

⁷Refers to the input current when the part is not converting. Primarily due to reverse leakage current in the ESD protection diodes.

Specifications subject to change without notice.

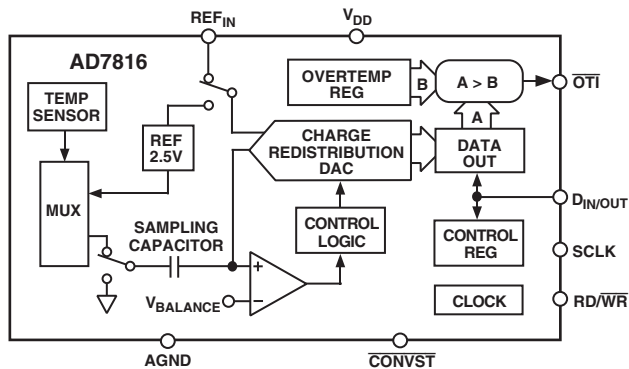

Figure 1. AD7816 Functional Block Diagram

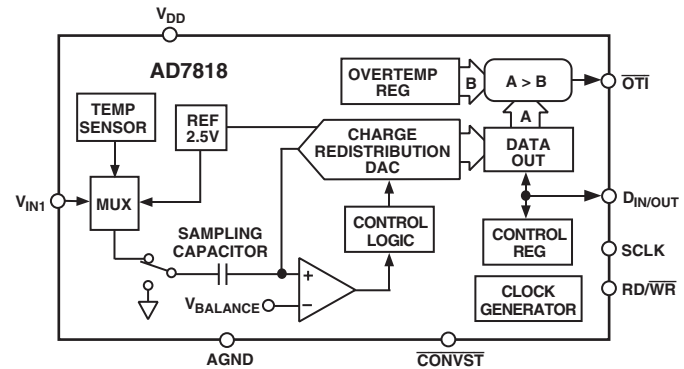

Figure 2. AD7818 Functional Block Diagram

TIMING CHARACTERISTICS^{1, 2} ($V_{DD} = 2.7\text{ V to }5.5\text{ V}$, $GND = 0\text{ V}$, $REF_{IN} = 2.5\text{ V}$. All specifications T_{MIN} to T_{MAX} unless otherwise noted)

Parameter	A, B Versions	Unit	Test Conditions/Comments
$t_{POWER-UP}$	2	$\mu\text{s max}$	Power-Up Time from Rising Edge of \overline{CONVST}
t_{1a}	9	$\mu\text{s max}$	Conversion Time Channels 1 to 4
t_{1b}	27	$\mu\text{s max}$	Conversion Time Temperature Sensor
t_2	20	ns min	\overline{CONVST} Pulse Width
t_3	50	ns max	\overline{CONVST} Falling Edge to $BUSY$ Rising Edge
t_4	0	ns min	\overline{CS} Falling Edge to $\overline{RD}/\overline{WR}$ Falling Edge Setup Time
t_5	0	ns min	$\overline{RD}/\overline{WR}$ Falling Edge to $SCLK$ Falling Edge Setup
t_6	10	ns min	D_{IN} Setup Time before $SCLK$ Rising Edge
t_7	10	ns min	D_{IN} Hold Time after $SCLK$ Rising Edge
t_8	40	ns min	$SCLK$ Low Pulse Width
t_9	40	ns min	$SCLK$ High Pulse Width
t_{10}	0	ns min	\overline{CS} Falling Edge to $\overline{RD}/\overline{WR}$ Rising Edge Setup Time
t_{11}	0	ns min	$\overline{RD}/\overline{WR}$ Rising Edge to $SCLK$ Falling Edge Setup Time
t_{12}^3	20	ns max	D_{OUT} Access Time after $\overline{RD}/\overline{WR}$ Rising Edge
t_{13}^3	20	ns max	D_{OUT} Access Time after $SCLK$ Falling Edge
$t_{14a}^{3, 4}$	30	ns max	D_{OUT} Bus Relinquish Time after Falling Edge of $\overline{RD}/\overline{WR}$
$t_{14b}^{3, 4}$	30	ns max	D_{OUT} Bus Relinquish Time after Rising Edge of \overline{CS}
t_{15}	150	ns max	$BUSY$ Falling Edge to \overline{OTI} Falling Edge
t_{16}	40	ns min	$\overline{RD}/\overline{WR}$ Rising Edge to \overline{OTI} Rising Edge
t_{17}	400	ns min	$SCLK$ Rising Edge to \overline{CONVST} Falling Edge (Acquisition Time of T/H)

NOTES

¹Sample tested during initial release and after any redesign or process change that may affect this parameter. All input signals are measured with $t_r = t_f = 1\text{ ns}$ (10% to 90% of 5 V) and timed from a voltage level of 1.6 V.

²See Figures 16, 17, 20 and 21.

³These figures are measured with the load circuit of Figure 3. They are defined as the time required for D_{OUT} to cross 0.8 V or 2.4 V for $V_{DD} = 5\text{ V} \pm 10\%$ and 0.4 V or 2 V for $V_{DD} = 3\text{ V} \pm 10\%$, as quoted on the specifications page of this data sheet.

⁴These times are derived from the measured time taken by the data outputs to change 0.5 V when loaded with the circuit of Figure 3. The measured number is then extrapolated back to remove the effects of charging or discharging the 50 pF capacitor. This means that the times quoted in the timing characteristics are the true bus relinquish times of the part and as such are independent of external bus loading capacitances.

Specifications subject to change without notice.

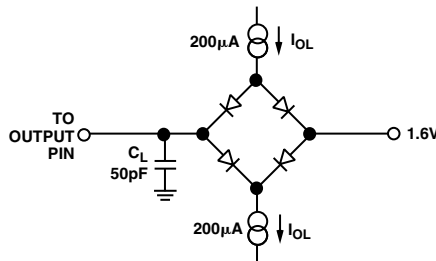

Figure 3. Load Circuit for Access Time and Bus Relinquish Time

AD7816/AD7817/AD7818

ABSOLUTE MAXIMUM RATINGS¹

($T_A = 25^\circ\text{C}$ unless otherwise noted)

V_{DD} to AGND	-0.3 V to +7 V
V_{DD} to DGND	-0.3 V to +7 V
Analog Input Voltage to AGND	
V_{IN1} to V_{IN4}	-0.3 V to $V_{DD} + 0.3$ V
Reference Input Voltage to AGND ²	-0.3 V to $V_{DD} + 0.3$ V
Digital Input Voltage to DGND	-0.3 V to $V_{DD} + 0.3$ V
Digital Output Voltage to DGND	-0.3 V to $V_{DD} + 0.3$ V
Storage Temperature Range	-65°C to $+150^\circ\text{C}$
Junction Temperature	150°C
TSSOP, Power Dissipation	450 mW
θ_{JA} Thermal Impedance	$120^\circ\text{C}/\text{W}$
Lead Temperature, Soldering	
Vapor Phase (60 sec)	215°C
Infrared (15 sec)	220°C
16-Lead SOIC Package, Power Dissipation	450 mW
θ_{JA} Thermal Impedance	$100^\circ\text{C}/\text{W}$
Lead Temperature, Soldering	
Vapor Phase (60 sec)	215°C
Infrared (15 sec)	220°C
8-Lead SOIC Package, Power Dissipation	450 mW
θ_{JA} Thermal Impedance	$157^\circ\text{C}/\text{W}$
Lead Temperature, Soldering	
Vapor Phase (60 sec)	215°C
Infrared (15 sec)	220°C

μSOIC Package, Power Dissipation	450 mW
θ_{JA} Thermal Impedance	$206^\circ\text{C}/\text{W}$
Lead Temperature, Soldering	
Vapor Phase (60 sec)	215°C
Infrared (15 sec)	220°C

NOTES

¹Stresses above those listed under Absolute Maximum Ratings may cause permanent damage to the device. This is a stress rating only; functional operation of the device at these or any other conditions above those listed in the operational sections of this specification is not implied. Exposure to absolute maximum rating conditions for extended periods may affect device reliability.

²If the Reference Input Voltage is likely to exceed V_{DD} by more than 0.3 V (e.g., during power-up) and the reference is capable of supplying 30 mA or more, it is recommended to use a clamping diode between the REF_{IN} pin and V_{DD} pin. The diagram below shows how the diode should be connected.

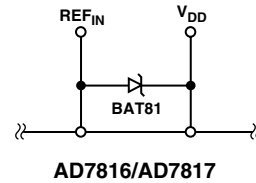

ORDERING GUIDE

Model	Temperature Range	Temperature Error @ +25°C	Package Description	Package Options	Branding
AD7816AR	-40°C to +85°C	±2°C	8-Lead Narrow Body (SOIC)	R-8	
AD7816AR-REEL	-40°C to +85°C	±2°C	8-Lead Narrow Body (SOIC)	R-8	
AD7816AR-REEL7	-40°C to +85°C	±2°C	8-Lead Narrow Body (SOIC)	R-8	
AD7816ARM	-40°C to +85°C	±2°C	8-Lead MSOP	RM-8	C4A
AD7816ARM-REEL	-40°C to +85°C	±2°C	8-Lead MSOP	RM-8	C4A
AD7816ARM-REEL7	-40°C to +85°C	±2°C	8-Lead MSOP	RM-8	C4A
AD7816ACHIPS			Die		
AD7817AR	-40°C to +85°C	±2°C	16-Lead Narrow Body (SOIC)	R-16	
AD7817AR-REEL	-40°C to +85°C	±2°C	16-Lead Narrow Body (SOIC)	R-16	
AD7817AR-REEL7	-40°C to +85°C	±2°C	16-Lead Narrow Body (SOIC)	R-16	
AD7817ARZ*	-40°C to +85°C	±2°C	16-Lead Narrow Body (SOIC)	R-16	
AD7817ARU	-40°C to +85°C	±2°C	16-Lead (TSSOP)	RU-16	
AD7817ARU-REEL	-40°C to +85°C	±2°C	16-Lead (TSSOP)	RU-16	
AD7817ARU-REEL7	-40°C to +85°C	±2°C	16-Lead (TSSOP)	RU-16	
AD7817BR	-40°C to +85°C	±1°C	16-Lead Narrow Body (SOIC)	R-16	
AD7817BR-REEL	-40°C to +85°C	±1°C	16-Lead Narrow Body (SOIC)	R-16	
AD7817BR-REEL7	-40°C to +85°C	±1°C	16-Lead Narrow Body (SOIC)	R-16	
AD7817BRZ*	-40°C to +85°C	±1°C	16-Lead Narrow Body (SOIC)	R-16	
AD7817BRZ-REEL*	-40°C to +85°C	±1°C	16-Lead Narrow Body (SOIC)	R-16	
AD7817BRZ-REEL7*	-40°C to +85°C	±1°C	16-Lead Narrow Body (SOIC)	R-16	
AD7817BRU	-40°C to +85°C	±1°C	16-Lead (TSSOP)	RU-16	
AD7817BRU-REEL	-40°C to +85°C	±1°C	16-Lead (TSSOP)	RU-16	
AD7817BRU-REEL7	-40°C to +85°C	±1°C	16-Lead (TSSOP)	RU-16	
AD7817SR	-40°C to +85°C	±2°C	16-Lead Narrow Body (SOIC)	R-16	
AD7817SR-REEL	-40°C to +85°C	±2°C	16-Lead Narrow Body (SOIC)	R-16	
AD7817SR-REEL7	-40°C to +85°C	±2°C	16-Lead Narrow Body (SOIC)	R-16	
AD7818AR	-40°C to +85°C	±2°C	16-Lead Narrow Body (SOIC)	R-16	
AD7818AR-REEL	-40°C to +85°C	±2°C	8-Lead Narrow Body (SOIC)	R-8	
AD7818AR-REEL7	-40°C to +85°C	±2°C	8-Lead Narrow Body (SOIC)	R-8	
AD7818ARM	-40°C to +85°C	±2°C	8-Lead MSOP	RM-8	C3A
AD7818ARM-REEL	-40°C to +85°C	±2°C	8-Lead MSOP	RM-8	C3A
AD7818ARM-REEL7	-40°C to +85°C	±2°C	8-Lead MSOP	RM-8	C3A
EVAL-AD7816/ AD7817/AD7818EB			Evaluation Board		

*Z = Pb free part

CAUTION

ESD (electrostatic discharge) sensitive device. Electrostatic charges as high as 4000 V readily accumulate on the human body and test equipment and can discharge without detection. Although the AD7816/AD7817/AD7818 features proprietary ESD protection circuitry, permanent damage may occur on devices subjected to high energy electrostatic discharges. Therefore, proper ESD precautions are recommended to avoid performance degradation or loss of functionality.



AD7816/AD7817/AD7818

AD7817 PIN FUNCTION DESCRIPTIONS

Pin	Mnemonic	Description
1	$\overline{\text{CONVST}}$	Logic Input Signal. The convert start signal. A 10-bit analog-to-digital conversion is initiated on the falling edge of this signal. The falling edge of this signal places the track/hold in hold mode. The track/hold goes into track mode again at the end of the conversion. The state of the $\overline{\text{CONVST}}$ signal is checked at the end of a conversion. If it is logic low, the AD7817 will power-down—see Operating Mode section of the data sheet.
2	BUSY	Logic Output. The busy signal is logic high during a temperature or voltage A/D conversion. The signal can be used to interrupt a microcontroller when a conversion has finished.
3	$\overline{\text{OTI}}$	Logic Output. The Overtemperature Indicator ($\overline{\text{OTI}}$) is set logic low if the result of a conversion on Channel 0 (Temperature Sensor) is greater than an 8-bit word in the Overtemperature Register (OTR). The signal is reset at the end of a serial read operation, i.e., a rising $\text{RD}/\overline{\text{WR}}$ edge when $\overline{\text{CS}}$ is low.
4	$\overline{\text{CS}}$	Logic Input Signal. The chip select signal is used to enable the serial port of the AD7817. This is necessary if the AD7817 is sharing the serial bus with more than one device.
5	AGND	Analog Ground. Ground reference for track/hold, comparator and capacitor DAC.
6	REF_{IN}	Analog Input. An external 2.5 V reference can be connected to the AD7817 at this pin. To enable the on-chip reference the REF_{IN} pin should be tied to AGND. If an external reference is connected to the AD7817, the internal reference will shut down.
7–10	$\text{V}_{\text{IN}1}$ to $\text{V}_{\text{IN}4}$	Analog Input Channels. The AD7817 has four analog input channels. The input channels are single-ended with respect to AGND (analog ground). The input channels can convert voltage signals in the range 0 V to V_{REF} . A channel is selected by writing to the Address Register of the AD7817—see Control Byte section.
11	V_{DD}	Positive Supply Voltage, 2.7 V to 5.5 V.
12	DGND	Digital Ground. Ground reference for digital circuitry.
13	D_{OUT}	Logic Output With a High Impedance State. Data is clocked out of the AD7817 serial port at this pin. This output goes into a high impedance state on the falling edge of $\text{RD}/\overline{\text{WR}}$ or on the rising edge of the $\overline{\text{CS}}$ signal, whichever occurs first.
14	D_{IN}	Logic Input. Data is clocked into the AD7817 at this pin.
15	SCLK	Clock Input for the Serial Port. The serial clock is used to clock data into and out of the AD7817. Data is clocked out on the falling edge and clocked in on the rising edge.
16	$\text{RD}/\overline{\text{WR}}$	Logic Input Signal. The read/write signal is used to indicate to the AD7817 whether the data transfer operation is a read or a write. The $\text{RD}/\overline{\text{WR}}$ should be set logic high for a read operation and logic low for a write operation.

PIN CONFIGURATION SOIC/TSSOP

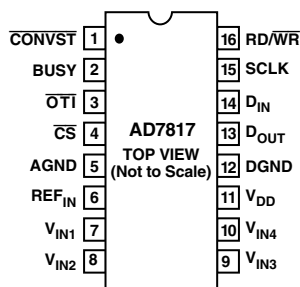

AD7816 AND AD7818 PIN FUNCTION DESCRIPTIONS

Pin	Mnemonic	Description
1	$\overline{\text{CONVST}}$	Logic Input Signal. The convert start signal initiates a 10-bit analog-to-digital conversion on the falling edge of the this signal. The falling edge of this signal places the track/hold in hold mode. The track/hold goes into track mode again at the end of the conversion. The state of the $\overline{\text{CONVST}}$ signal is checked at the end of a conversion. If it is logic low, the AD7816 and AD7818 will power down—see Operating Mode section of the data sheet.
2	$\overline{\text{OTI}}$	Logic Output. The Overtemperature Indicator ($\overline{\text{OTI}}$) is set logic low if the result of a conversion on Channel 0 (Temperature Sensor) is greater than an 8-bit word in the Overtemperature Register (OTR). The signal is reset at the end of a serial read operation, i.e., a rising $\text{RD}/\overline{\text{WR}}$ edge.
3	GND	Analog and Digital Ground.
4 (AD7818)	V_{IN}	Analog Input Channel. The input channel is single-ended with respect to GND. The input channel can convert voltage signals in the range 0 V to 2.5 V. The input channel is selected by writing to the Address Register of the AD7818—see Control Byte section.
4 (AD7816)	REF_{IN}	Reference Input. An external 2.5 V reference can be connected to the AD7816 at this pin. To enable the on-chip reference the REF_{IN} pin should be tied to AGND. If an external reference is connected to the AD7816, the internal reference will shut down.
5	V_{DD}	Positive supply voltage, 2.7 V to 5.5 V.
6	$\text{D}_{\text{IN/OUT}}$	Logic Input and Output. Serial data is clocked in and out of the AD7816/AD7818 at this pin.
7	SCLK	Clock Input for the Serial Port. The serial clock is used to clock data into and out of the AD7816/AD7818. Data is clocked out on the falling edge and clocked in on the rising edge.
8	$\text{RD}/\overline{\text{WR}}$	Logic Input. The read/write signal is used to indicate to the AD7816 and AD7818 whether the next data transfer operation is a read or a write. The $\text{RD}/\overline{\text{WR}}$ should be set logic high for a read operation and logic low for a write.

PIN CONFIGURATIONS

SOIC/MSOP (AD7816)

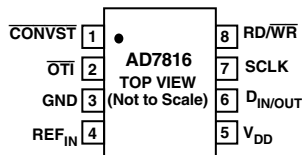

SOIC/MSOP (AD7818)

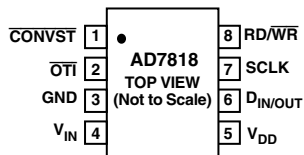

TERMINOLOGY

Signal-to-(Noise + Distortion) Ratio

This is the measured ratio of signal-to-(noise + distortion) at the output of the A/D converter. The signal is the rms amplitude of the fundamental. Noise is the rms sum of all nonfundamental signals up to half the sampling frequency ($f_s/2$), excluding dc. The ratio is dependent upon the number of quantization levels in the digitization process; the more levels, the smaller the quantization noise. The theoretical signal-to-(noise + distortion) ratio for an ideal N-bit converter with a sine wave input is given by:

$$\text{Signal-to-(Noise + Distortion)} = (6.02 N + 1.76) \text{ dB}$$

Thus for a 10-bit converter, this is 62 dB.

Total Harmonic Distortion

Total harmonic distortion (THD) is the ratio of the rms sum of harmonics to the fundamental. For the AD7891 it is defined as:

$$\text{THD (dB)} = 20 \log \frac{\sqrt{V_2^2 + V_3^2 + V_4^2 + V_5^2 + V_6^2}}{V_1}$$

where V_1 is the rms amplitude of the fundamental and V_2 , V_3 , V_4 , V_5 , and V_6 are the rms amplitudes of the second through the sixth harmonics.

Peak Harmonic or Spurious Noise

Peak harmonic or spurious noise is defined as the ratio of the rms value of the next largest component in the ADC output spectrum (up to $f_s/2$ and excluding dc) to the rms value of the fundamental. Normally, the value of this specification is determined by the largest harmonic in the spectrum, but for parts where the harmonics are buried in the noise floor, it will be a noise peak.

Intermodulation Distortion

With inputs consisting of sine waves at two frequencies, f_a and f_b , any active device with nonlinearities will create distortion products at sum and difference frequencies of $m f_a \pm n f_b$ where $m, n = 0, 1, 2, 3$, etc. Intermodulation terms are those for which neither m nor n are equal to zero. For example, the second order terms include $(f_a + f_b)$ and $(f_a - f_b)$, while the third order terms include $(2f_a + f_b)$, $(2f_a - f_b)$, $(f_a + 2f_b)$ and $(f_a - 2f_b)$.

AD7816/AD7817/AD7818

The AD7816, AD7817, and AD7818 are tested using the CCIF standard where two input frequencies near the top end of the input bandwidth are used. In this case, the second and third order terms are of different significance. The second order terms are usually distanced in frequency from the original sine waves while the third order terms are usually at a frequency close to the input frequencies. As a result, the second and third order terms are specified separately. The calculation of the intermodulation distortion is as per the THD specification where it is the ratio of the rms sum of the individual distortion products to the rms amplitude of the fundamental expressed in dBs.

Channel-to-Channel Isolation

Channel-to-channel isolation is a measure of the level of crosstalk between channels. It is measured by applying a full-scale 20 kHz sine wave signal to one input channel and determining how much that signal is attenuated in each of the other channels. The figure given is the worst case across all four channels.

Relative Accuracy

Relative accuracy or endpoint nonlinearity is the maximum deviation from a straight line passing through the endpoints of the ADC transfer function.

Differential Nonlinearity

This is the difference between the measured and the ideal 1 LSB change between any two adjacent codes in the ADC.

Offset Error

This is the deviation of the first code transition (0000 . . . 000) to (0000 . . . 001) from the ideal, i.e., AGND + 1 LSB.

Offset Error Match

This is the difference in Offset Error between any two channels.

Gain Error

This is the deviation of the last code transition (1111 . . . 110) to (1111 . . . 111) from the ideal, i.e., VREF – 1 LSB, after the offset error has been adjusted out.

Gain Error Match

This is the difference in Gain Error between any two channels.

Track/Hold Acquisition Time

Track/hold acquisition time is the time required for the output of the track/hold amplifier to reach its final value, within $\pm 1/2$ LSB, after the end of conversion (the point at which the track/hold returns to track mode). It also applies to situations where a change in the selected input channel takes place or where there is a step input change on the input voltage applied to the selected V_{IN} input of the AD7817 or AD7818. It means that the user must wait for the duration of the track/hold acquisition time after the end of conversion or after a channel change/step input change to V_{IN} before starting another conversion, to ensure that the part operates to specification.

CONTROL BYTE

The AD7816, AD7817, and AD7818 contain two on-chip registers, the Address Register and the Overtemperature Register. These registers can be accessed by carrying out an 8-bit serial write operation to the devices. The 8-bit word or control byte written to the AD7816, AD7817, and AD7818 is transferred to one of the two on-chip registers as follows.

Address Register

If the five MSBs of the control byte are logic zero, the three LSBs of the control byte are transferred to the Address Register—see Figure 4. The Address Register is a 3-bit-wide register used to select the analog input channel on which to carry out a conversion. It is also used to select the temperature sensor, which has the address 000. Table I shows the selection. The Internal Reference selection connects the input of the ADC to the band gap reference. When this selection is made and a conversion is initiated, the ADC output should be approximately mid-scale. After power-up the default channel selection is DB2 = DB1 = DB0 = 0 (Temperature Sensor).

Table I. Channel Selection

DB2	DB1	DB0	Channel Selection	Device
0	0	0	Temperature Sensor	All
0	0	1	Channel 1	AD7817/AD7818
0	1	0	Channel 2	AD7817
0	1	1	Channel 3	AD7817
1	0	0	Channel 4	AD7817
1	1	1	Internal Ref (1.23 V)	All

Overtemperature Register

If any of the five MSBs of the control byte are logic one, then the entire eight bits of the control byte are transferred to the Overtemperature Register—see Figure 4. At the end of a temperature conversion a digital comparison is carried out between the 8 MSBs of the temperature conversion result (10 bits) and the contents of the Overtemperature Register (8 bits). If the result of the temperature conversion is greater than the contents of the Overtemperature Register (OTR), then the Overtemperature Indicator (\overline{OTI}) goes logic low. The resolution of the OTR is 1°C. The lowest temperature that can be written to the OTR is –95°C and the highest is +152°C—see Figure 5. However, the usable temperature range of the temperature sensor is –55°C to +125°C. Figure 5 shows the OTR and how to set T_{ALARM} (the temperature at which the \overline{OTI} goes low).

$$OTR (Dec) = T_{ALARM} (^\circ C) + 103^\circ C$$

For example, to set T_{ALARM} to 50°C, $OTR = 50 + 103 = 153$ Dec or 10011001 Bin. If the result of a temperature conversion exceeds 50°C then \overline{OTI} will go logic low. The \overline{OTI} logic output is reset high at the end of a serial read operation or if a new temperature measurement is lower than T_{ALARM} . The default power on T_{ALARM} is 50°C.

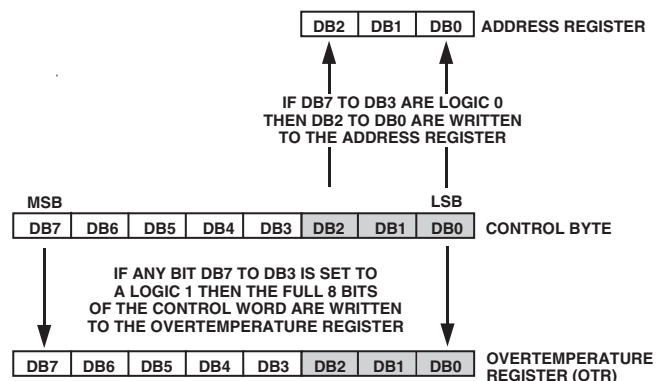

Figure 4. Address and Overtemperature Register Selection

OVERTEMPERATURE REGISTER							
MSB				LSB			
DB7	DB6	DB5	DB4	DB3	DB2	DB1	DB0
0	0	0	0	1	0	0	0
1	1	1	1	1	1	1	1

MINIMUM TEMPERATURE = -95°C
MAXIMUM TEMPERATURE = $+152^{\circ}\text{C}$

OVERTEMPERATURE REGISTER (DEC) = $T_{\text{ALARM}} + 103^{\circ}\text{C}$
 T_{ALARM} RESOLUTION = 1°/LSB

Figure 5. The Overtemperature Register (OTR)

CIRCUIT INFORMATION

The AD7817 and AD7818 are single- and four-channel, 9 μs conversion time, 10-bit A/D converters with on-chip temperature sensor, reference, and serial interface logic functions on a single chip. The AD7816 has no analog input channel and is intended for temperature measurement only. The A/D converter section consists of a conventional successive-approximation converter based around a capacitor DAC. The AD7816, AD7817, and AD7818 are capable of running on a 2.7 V to 5.5 V power supply and the AD7817 and AD7818 accept an analog input range of 0 V to $+V_{\text{REF}}$. The on-chip temperature sensor allows an accurate measurement of the ambient device temperature to be made. The working measurement range of the temperature sensor is -55°C to $+125^{\circ}\text{C}$. The part requires a 2.5 V reference, which can be provided from the part's own internal reference or from an external reference source. The on-chip reference is selected by connecting the REF_{IN} pin to analog ground.

CONVERTER DETAILS

Conversion is initiated by pulsing the $\overline{\text{CONVST}}$ input. The conversion clock for the part is internally generated so no external clock is required except when reading from and writing to the serial port. The on-chip track/hold goes from track-to-hold mode and the conversion sequence is started on the falling edge of the $\overline{\text{CONVST}}$ signal. At this point the BUSY signal goes high and low again 9 μs or 27 μs later (depending on whether an analog input or the temperature sensor is selected) to indicate the end of the conversion process. This signal can be used by a microcontroller to determine when the result of the conversion should be read. The track/hold acquisition time of the AD7817 and AD7818 is 400 ns.

A temperature measurement is made by selecting the Channel 0 of the on-chip MUX and carrying out a conversion on this channel. A conversion on Channel 0 takes 27 μs to complete. Temperature measurement is explained in the Temperature Measurement section of this data sheet.

The on-chip reference is not available to the user, but REF_{IN} can be overdriven by an external reference source (2.5 V only). The effect of reference tolerances on temperature measurements is discussed in the section titled Temperature Measurement Error Due to Reference Error.

All unused analog inputs should be tied to a voltage within the nominal analog input range to avoid noise pickup. For minimum power consumption, the unused analog inputs should be tied to AGND.

TYPICAL CONNECTION DIAGRAM

Figure 6 shows a typical connection diagram for the AD7817. The AGND and DGND are connected together at the device for good noise suppression. The BUSY line is used to interrupt the microcontroller at the end of the conversion process and the serial interface is implemented using three wires—see Serial Interface section for more details. An external 2.5 V reference can be connected at the REF_{IN} pin. If an external reference is used, a 10 μF capacitor should be connected between REF_{IN} and AGND. For applications where power consumption is of concern, the automatic power-down at the end of a conversion should be used to improve power performance. See Power vs. Throughput section of this data sheet.

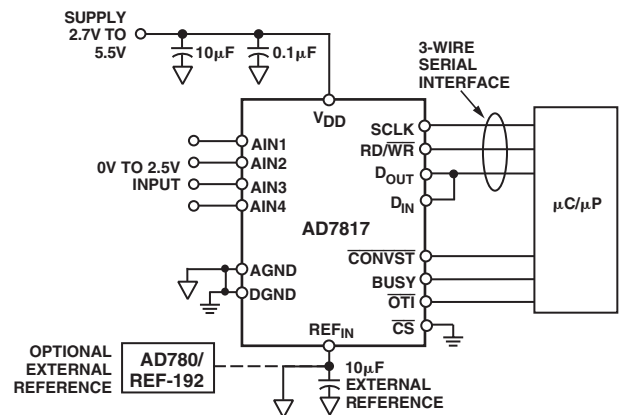

Figure 6. Typical Connection Diagram

ANALOG INPUTS

Analog Input

Figure 7 shows an equivalent circuit of the analog input structure of the AD7817 and AD7818. The two diodes D1 and D2 provide ESD protection for the analog inputs. Care must be taken to ensure that the analog input signal never exceeds the supply rails by more than 200 mV. This will cause these diodes to become forward biased and start conducting current into the substrate. The maximum current these diodes can conduct without causing irreversible damage to the part is 20 mA. The capacitor C2 in Figure 7 is typically about 4 pF and can mostly be attributed to pin capacitance. The resistor R1 is a lumped component made up of the on resistance of a multiplexer and a switch. This resistor is typically about 1 k Ω . The capacitor C1 is the ADC sampling capacitor and has a capacitance of 3 pF.

AD7816/AD7817/AD7818

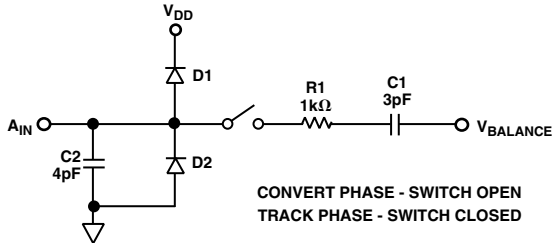

Figure 7. Equivalent Analog Input Circuit

DC Acquisition Time

The ADC starts a new acquisition phase at the end of a conversion and ends on the falling edge of the CONVST signal. At the end of a conversion a settling time is associated with the sampling circuit. This settling time lasts approximately 100 ns. The analog signal on V_{IN+} is also being acquired during this settling time. Therefore, the minimum acquisition time needed is approximately 100 ns.

Figure 8 shows the equivalent charging circuit for the sampling capacitor when the ADC is in its acquisition phase. R2 represents the source impedance of a buffer amplifier or resistive network, R1 is an internal multiplexer resistance and C1 is the sampling capacitor.

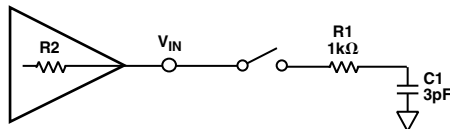

Figure 8. Equivalent Sampling Circuit

During the acquisition phase the sampling capacitor must be charged to within a 1/2 LSB of its final value. The time it takes to charge the sampling capacitor (T_{CHARGE}) is given by the following formula:

$$T_{CHARGE} = 7.6 \times (R2 + 1 \text{ k}\Omega) \times 3 \text{ pF}$$

For small values of source impedance, the settling time associated with the sampling circuit (100 ns) is, in effect, the acquisition time of the ADC. For example, with a source impedance (R2) of 10 Ω the charge time for the sampling capacitor is approximately 23 ns. The charge time becomes significant for source impedances of 1 k Ω and greater.

AC Acquisition Time

In ac applications it is recommended to always buffer analog input signals. The source impedance of the drive circuitry must be kept as low as possible to minimize the acquisition time of the ADC. Large values of source impedance will cause the THD to degrade at high throughput rates.

ON-CHIP REFERENCE

The AD7816, AD7817, and AD7818 have an on-chip 1.2 V band gap reference that is gained up to give an output of 2.5 V. The on-chip reference is selected by connecting the REF_{IN} pin to analog ground. This causes SW1 (see Figure 9) to open and the reference amplifier to power up during a conversion. Therefore, the on-chip reference is not available externally. An external 2.5 V reference can be connected to the REF_{IN} pin. This has the effect of shutting down the on-chip reference circuitry and reducing I_{DD} by about 0.25 mA.

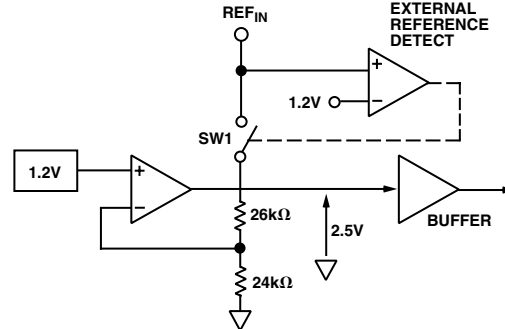

Figure 9. On-Chip Reference

ADC TRANSFER FUNCTION

The output coding of the AD7816, AD7817, and AD7818 is straight binary. The designed code transitions occur at successive integer LSB values (i.e., 1 LSB, 2 LSBs, etc.). The LSB size is $= 2.5 \text{ V}/1024 = 2.44 \text{ mV}$. The ideal transfer characteristic is shown in Figure 10 below.

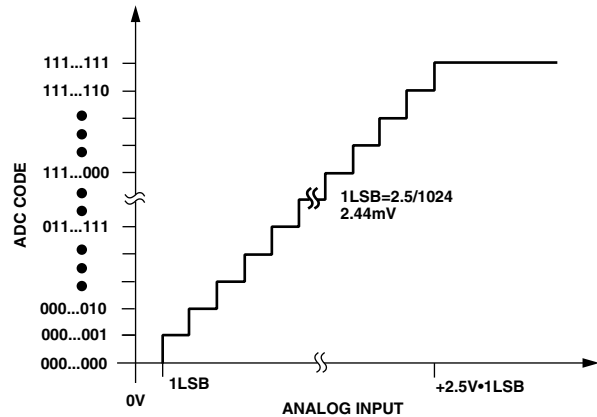

Figure 10. ADC Transfer Function

TEMPERATURE MEASUREMENT

The on-chip temperature sensor can be accessed via multiplexer Channel 0, i.e., by writing 000 to the channel address register. The temperature is also the power on default selection. The transfer characteristic of the temperature sensor is shown in Figure 11 below. The result of the 10-bit conversion on Channel 0 can be converted to degrees centigrade by using the following equation.

$$T_{AMB} = -103^{\circ}\text{C} + (\text{ADC Code}/4)$$

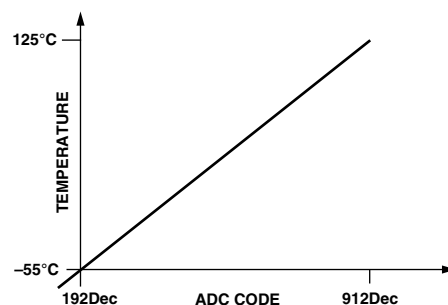

Figure 11. Temperature Sensor Transfer Characteristic

For example, if the result of a conversion on Channel 0 was 1000000000 (512 Dec), the ambient temperature is equal to $-103^{\circ}\text{C} + (512/4) = +25^{\circ}\text{C}$.

Table II below shows some ADC codes for various temperatures.

Table II. Temperature Sensor Output

ADC Code	Temperature
00 1100 0000	-55°C
01 0011 1000	-25°C
01 1001 1100	0°C
10 0000 0000	+25°C
10 0111 1000	+55°C
11 1001 0000	+125°C

TEMPERATURE MEASUREMENT ERROR DUE TO REFERENCE ERROR

The AD7816, AD7817, and AD7818 are trimmed using a precision 2.5 V reference to give the transfer function described previously. To show the effect of the reference tolerance on a temperature reading, the temperature sensor transfer function can be rewritten as a function of the reference voltage and the temperature.

$$CODE (Dec) = ([113.3285 \times K \times T] / [q \times V_{REF}] - 0.6646) \times 1024$$

where:

$$K = \text{Boltzmann's Constant, } 1.38 \times 10^{-23}$$

$$q = \text{Charge on an electron, } 1.6 \times 10^{-19}$$

$$T = \text{Temperature (K)}$$

So, for example, to calculate the ADC code at 25°C

$$\begin{aligned} CODE &= ([113.3285 \times 298 \times 1.38 \times 10^{-23}] / [1.6 \times 10^{-19} \times 2.5] \\ &\quad - 0.6646) \times 1024 \\ &= 511.5 \text{ (200 Hex)} \end{aligned}$$

As can be seen from the expression, a reference error will produce a gain error. This means that the temperature measurement error due to reference error will be greater at higher temperatures. For example, with a reference error of -1%, the measurement error at -55°C would be 2.2 LSBs (0.5°C) and 16 LSBs (4°C) at 125°C.

SELF-HEATING CONSIDERATIONS

The AD7817 and AD7818 have an analog-to-digital conversion function capable of a throughput rate of 100 kSPS. At this throughput rate the AD7817 and AD7818 will consume between 4 mW and 6.5 mW of power. Because a thermal impedance is associated with the IC package, the temperature of the die will rise as a result of this power dissipation. The graphs below show the self-heating effect in a 16-lead SOIC package. Figures 12 and 13 show the self-heating effect on a two-layer and four-layer PCB. The plots were generated by assembling a heater (resistor)

and temperature sensor (diode) in the package being evaluated. In Figure 12, the heater (6 mW) is turned off after 30 sec. The PCB has little influence on the self-heating over the first few seconds after the heater is turned on. This can be more clearly seen in Figure 13 where the heater is switched off after 2 seconds. Figure 14 shows the relative effects of self-heating in air, fluid and in thermal contact with a large heat sink.

These diagrams represent the worst-case effects of self-heating. The heater delivered 6 mW to the interior of the package in all cases. This power level is equivalent to the ADC continuously converting at 100 kSPS. The effects of the self-heating can be reduced at lower ADC throughput rates by operating on Mode 2 (see Operating Modes section). When operating in this mode, the on-chip power dissipation reduces dramatically and, as a consequence, the self-heating effects.

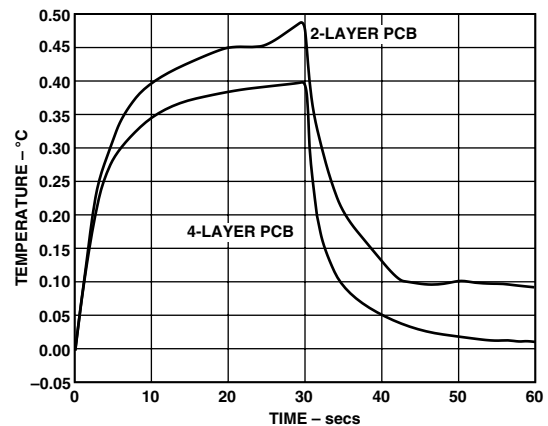

Figure 12. Self-Heating Effect Two-Layer and Four-Layer PCB

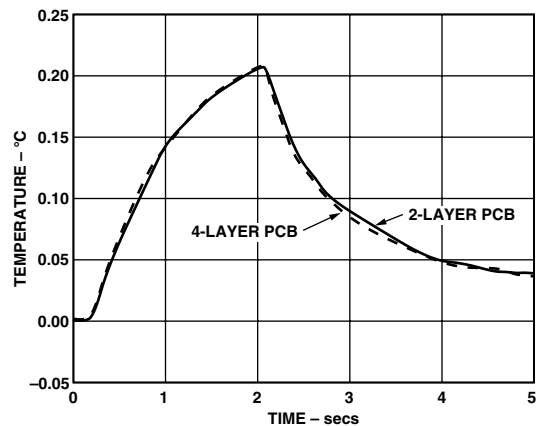

Figure 13. Self-Heating Effect Two-Layer and Four-Layer PCB

AD7816/AD7817/AD7818

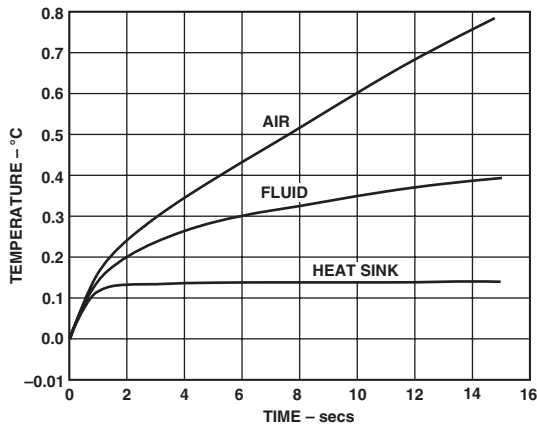

Figure 14. Self-Heating Effect in Air, Fluid, and in Thermal Contact with a Heat Sink

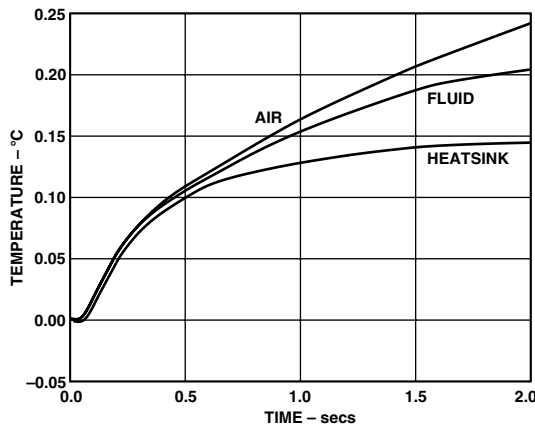

Figure 15. Self-Heating Effect in Air, Fluid, and in Thermal Contact with a Heat Sink

OPERATING MODES

The AD7816, AD7817, and AD7818 have two possible modes of operation depending on the state of the $\overline{\text{CONVST}}$ pulse at the end of a conversion.

Mode 1

In this mode of operation the $\overline{\text{CONVST}}$ pulse is brought high before the end of a conversion, i.e., before the $\overline{\text{BUSY}}$ goes low (see Figure 16). When operating in this mode a new conversion should not be initiated until 100 ns after the end of a serial read operation. This quiet time is to allow the track/hold to accurately acquire the input signal after a serial read.

Mode 2

When the AD7816, AD7817, and AD7818 are operated in Mode 2 (see Figure 17), they automatically power down at the end of a conversion. The $\overline{\text{CONVST}}$ is brought low to initiate a conversion and is left logic low until after the end of the conversion. At this point, i.e., when $\overline{\text{BUSY}}$ goes low, the devices will power-down. The devices are powered up again on the rising edge of the $\overline{\text{CONVST}}$ signal. Superior power performance can be achieved in this mode of operation by powering up the AD7816, AD7817, and AD7818 only to carry out a conversion (see Power vs. Throughput section). In Figure 17 the $\overline{\text{CS}}$ line is applicable to the AD7817 only.

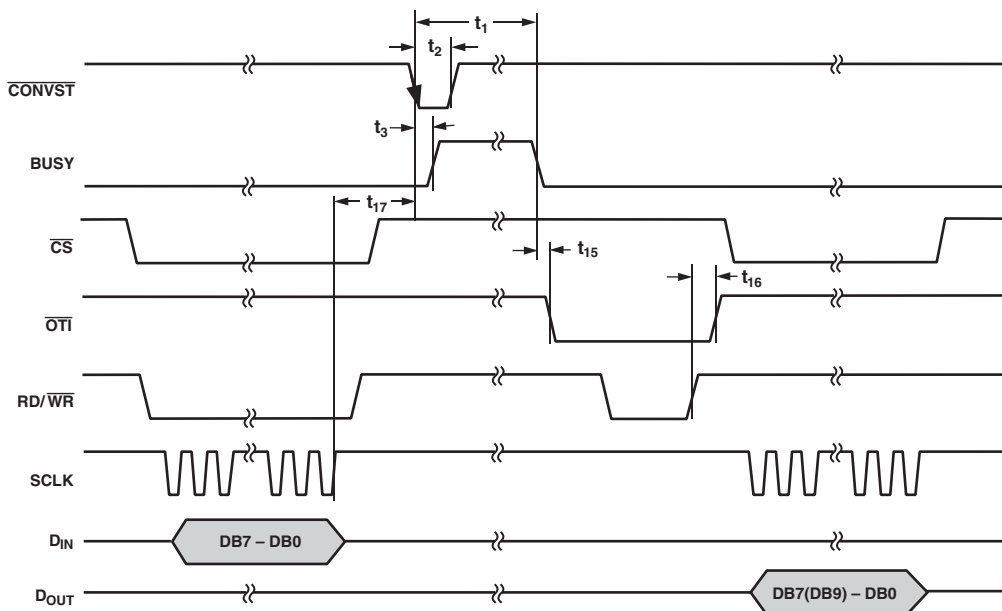

Figure 16. Mode 1 Operation

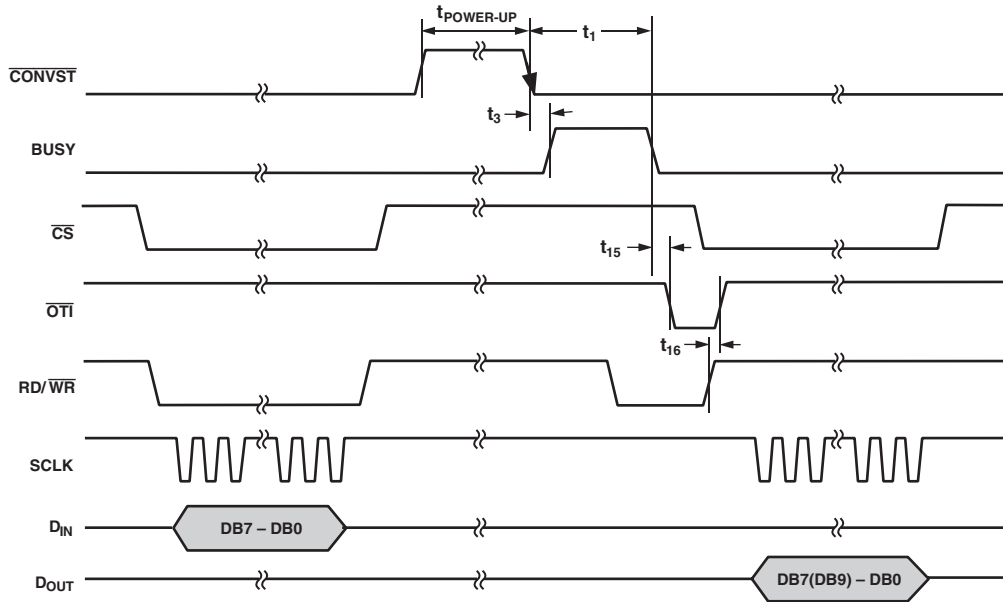

Figure 17. Mode 2 Operation

POWER VS. THROUGHPUT

Superior power performance can be achieved by using the Automatic Power-Down (Mode 2) at the end of a conversion (see Operating Modes section of this data sheet).

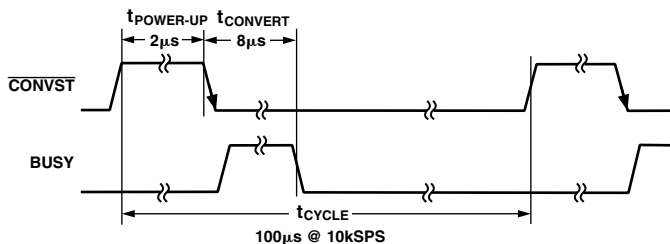

Figure 18. Automatic Power-Down

Figure 18 shows how the Automatic Power-Down is implemented to achieve the optimum power performance from the AD7816, AD7817, and AD7818. The devices are operated in Mode 2 and the duration of \overline{CONVST} pulse is set to be equal to the power-up time (2 μ s). As the throughput rate of the device is reduced the device remains in its power-down state longer, and the average power consumption over time drops accordingly.

For example, if the AD7817 is operated in a continuous sampling mode with a throughput rate of 10 kSPS, the power consumption is calculated as follows. The power dissipation during normal operation is 4.8 mW, $V_{DD} = 3$ V. If the power up time is 2 μ s and the conversion time is 9 μ s, the AD7817 can be said to dissipate 4.8 mW typically for 11 μ s (worst case) during each conversion cycle. If the throughput rate is 10 kSPS, the cycle time is 100 μ s and the power dissipated while powered up during each cycle is $(11/100) \times (4.8 \text{ mW}) = 528 \text{ } \mu$ W typ. Power dissipated while powered down during each cycle is $(89/100) \times (3 \text{ V} \times 2 \text{ } \mu$ A) = 5.34 μ W typ. Overall power dissipated is $528 \text{ } \mu$ W + 5.34 μ W = 533 μ W.

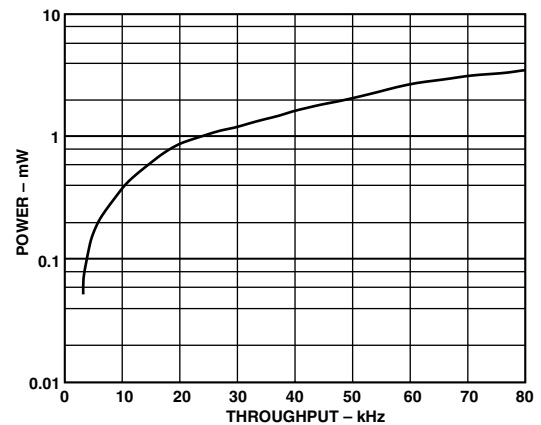

Figure 19. Power vs. Throughput Rate

AD7817 SERIAL INTERFACE

The serial interface on the AD7817 is a 5-wire interface with read and write capabilities, with data being read from the output register via the D_{OUT} line and data being written to the control register via the D_{IN} line. The part operates in a slave mode and requires an externally applied serial clock to the SCLK input to access data from the data register or write to the control byte. The $\overline{RD/WR}$ line is used to determine whether data is being written to or read from the AD7817. When data is being written to the AD7817, the $\overline{RD/WR}$ line is set logic low and when data is being read from the part the line is set logic high (see Figure 20). The serial interface on the AD7817 is designed to allow the part to be interfaced to systems that provide a serial clock that is synchronized to the serial data, such as the 80C51, 87C51, 68HC11, 68HC05, and PIC16Cxx microcontrollers.

AD7816/AD7817/AD7818

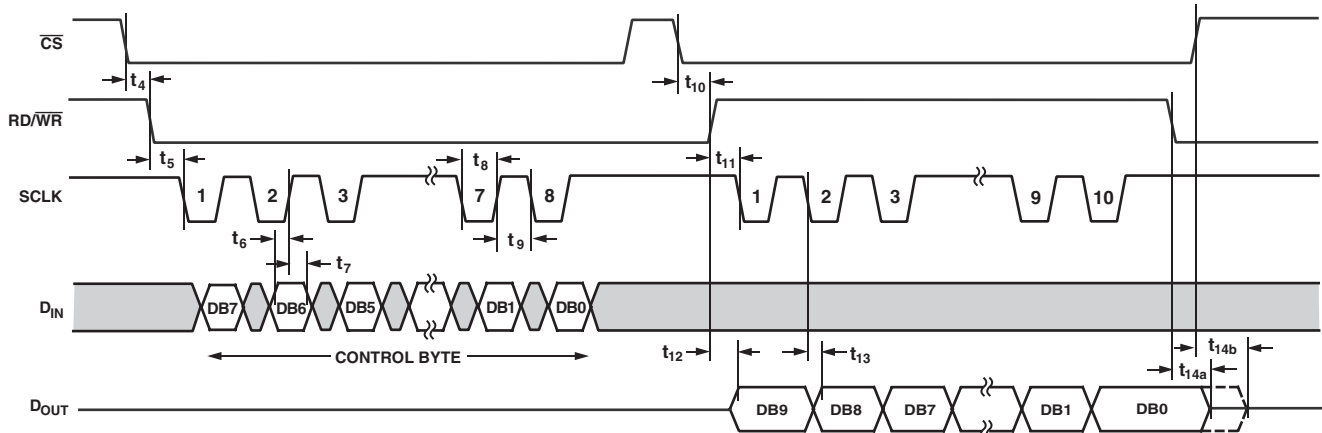

Figure 20. AD7817 Serial Interface Timing Diagram

Read Operation

Figure 20 shows the timing diagram for a serial read from the AD7817. \overline{CS} is brought low to enable the serial interface and $\overline{RD}/\overline{WR}$ is set logic high to indicate that the data transfer is a serial read from the AD7817. The rising edge of $\overline{RD}/\overline{WR}$ clocks out the first data bit (DB9), subsequent bits are clocked out on the falling edge of SCLK (except for the first falling SCLK edge) and are valid on the rising edge. 10 bits of data are transferred during a read operation. However, the user has the choice of clocking only eight bits if the full 10 bits of the conversion result are not required. The serial data can be accessed in a number of bytes if 10 bits of data are being read. However, $\overline{RD}/\overline{WR}$ must remain high for the duration of the data transfer operation. Before starting a new data read operation the $\overline{RD}/\overline{WR}$ signal must be brought low and high again. At the end of the read operation, the D_{OUT} line enters a high impedance state on the rising edge of the \overline{CS} or the falling edge of $\overline{RD}/\overline{WR}$, whichever occurs first. The readback process is a destructive process in that once the data is read back it is erased. A conversion must be done again; otherwise no data will be read back.

Write Operation

Figure 20 also shows a control byte write operation to the AD7817. The $\overline{RD}/\overline{WR}$ input goes low to indicate to the part that a serial write is about to occur. The AD7817 control byte is loaded on the rising edge of the first eight clock cycles of the serial clock with data on all subsequent clock cycles being ignored. To carry out a second successive write operation, the $\overline{RD}/\overline{WR}$ signal must be brought high and low again.

Simplifying the Serial Interface

To minimize the number of interconnect lines to the AD7817, the user can connect the \overline{CS} line to DGND. This is possible if the AD7817 is not sharing the serial bus with another device. It is also possible to tie the D_{IN} and D_{OUT} lines together. This arrangement is compatible with the 8051 microcontroller. The 68HC11, 68HC05, and PIC16Cxx can be configured to operate with a single serial data line. In this way the number of lines required to operate the serial interface can be reduced to three, i.e., $\overline{RD}/\overline{WR}$, SCLK, and D_{IN}/D_{OUT} (see Figure 6).

AD7816 AND AD7818 SERIAL INTERFACE MODE

The serial interface on the AD7816 and AD7818 is a 3-wire interface with read and write capabilities. Data is read from the

output register and the control byte is written to the AD7816 and AD7818 via the D_{IN}/D_{OUT} line. The part operates in a slave mode and requires an externally applied serial clock to the SCLK input to access data from the data register or write the control byte. The $\overline{RD}/\overline{WR}$ line is used to determine whether data is being written to or read from the AD7816 and AD7818. When data is being written to the devices the $\overline{RD}/\overline{WR}$ line is set logic low and when data is being read from the part the line is set logic high (see Figure 21). The serial interface on the AD7816 and AD7818 are designed to allow the part to be interfaced to systems that provide a serial clock that is synchronized to the serial data, such as the 80C51, 87C51, 68HC11, 68HC05, and PIC16Cxx microcontrollers.

Read Operation

Figure 21 shows the timing diagram for a serial read from the AD7816 and AD7818. The $\overline{RD}/\overline{WR}$ is set logic high to indicate that the data transfer is a serial read from the devices. When $\overline{RD}/\overline{WR}$ is logic high the D_{IN}/D_{OUT} pin becomes a logic output and the first data bit (DB9) appears on the pin. Subsequent bits are clocked out on the falling edge of SCLK, starting with the second SCLK falling edge after $\overline{RD}/\overline{WR}$ goes high and are valid on the rising edge of SCLK. Ten bits of data are transferred during a read operation. However the user has the choice of clocking only eight bits if the full 10 bits of the conversion result are not required. The serial data can be accessed in a number of bytes if 10 bits of data are being read; however, $\overline{RD}/\overline{WR}$ must remain high for the duration of the data transfer operation. To carry out a successive read operation the $\overline{RD}/\overline{WR}$ pin must be brought logic low and high again. At the end of the read operation, the D_{IN}/D_{OUT} pin becomes a logic input on the falling edge of $\overline{RD}/\overline{WR}$.

Write Operation

A control byte write operation to the AD7816 and AD7818 is also shown in Figure 21. The $\overline{RD}/\overline{WR}$ input goes low to indicate to the part that a serial write is about to occur. The AD7816 and AD7818 control bytes are loaded on the rising edge of the first eight clock cycles of the serial clock with data on all subsequent clock cycles being ignored. To carry out a successive write to the AD7816 or AD7818 the $\overline{RD}/\overline{WR}$ pin must be brought logic high and low again.

AD7816/AD7817/AD7818

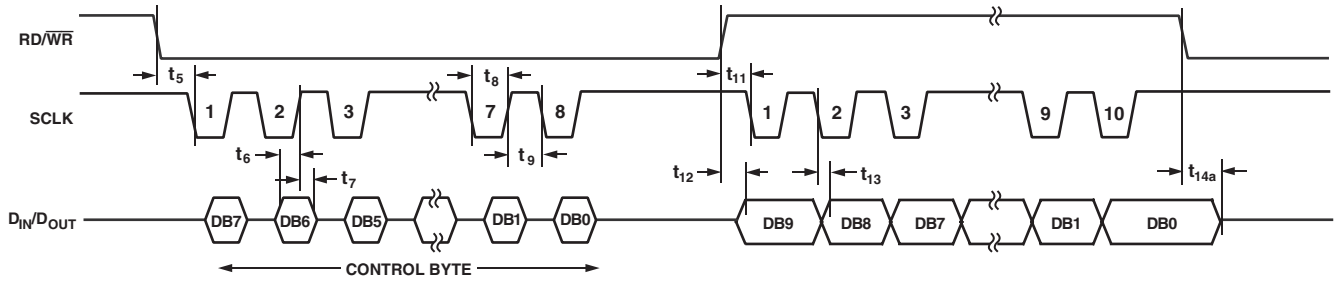
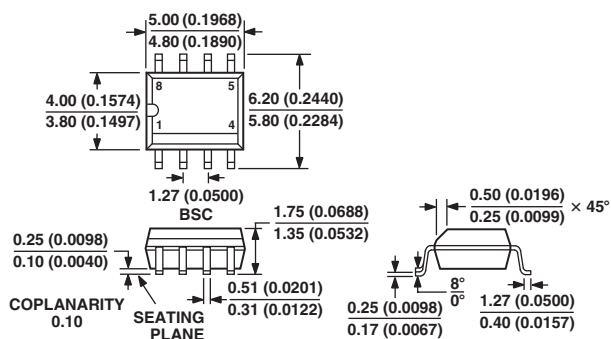

Figure 21. AD7816/AD7818 Serial Interface Timing Diagram

OUTLINE DIMENSIONS

8-Lead Standard Small Outline Package [SOIC] Narrow Body (R-8)

Dimensions shown in millimeters and (inches)



COMPLIANT TO JEDEC STANDARDS MS-012AA
CONTROLLING DIMENSIONS ARE IN MILLIMETERS; INCH DIMENSIONS (IN PARENTHESES) ARE ROUNDED-OFF MILLIMETER EQUIVALENTS FOR REFERENCE ONLY AND ARE NOT APPROPRIATE FOR USE IN DESIGN

8-Lead Mini Small Outline Package [MSOP] (RM-8)

Dimensions shown in millimeters

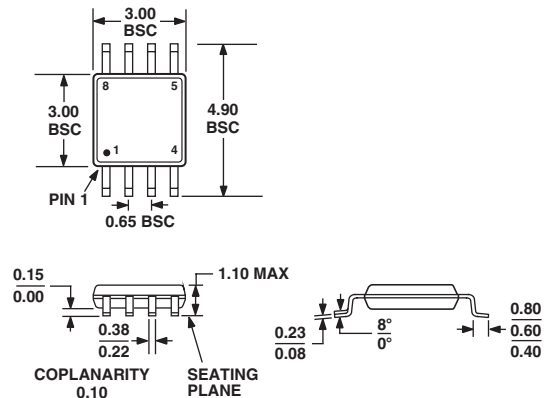

COMPLIANT TO JEDEC STANDARDS MO-187AA

16-Lead Standard Small Outline Package [SOIC] Narrow Body (R-16)

Dimensions shown in millimeters and (inches)

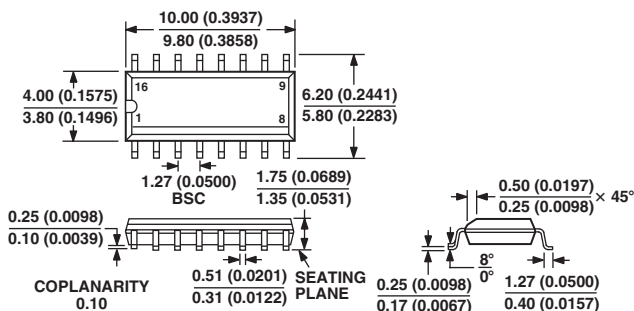

COMPLIANT TO JEDEC STANDARDS MS-012AC
CONTROLLING DIMENSIONS ARE IN MILLIMETERS; INCH DIMENSIONS (IN PARENTHESES) ARE ROUNDED-OFF MILLIMETER EQUIVALENTS FOR REFERENCE ONLY AND ARE NOT APPROPRIATE FOR USE IN DESIGN

16-Lead Thin Shrink Small Outline Package [TSSOP] (RU-16)

Dimensions shown in millimeters

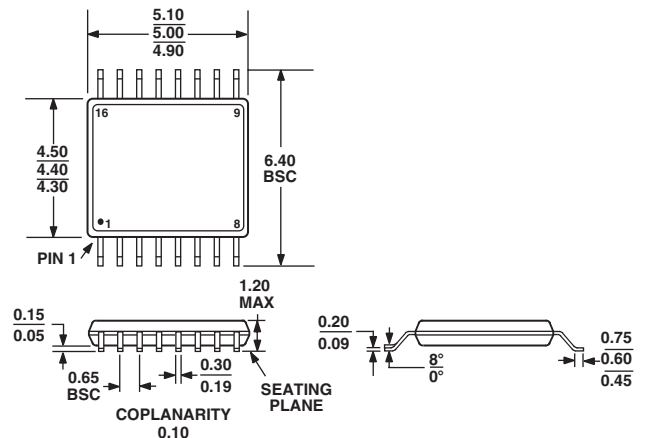

COMPLIANT TO JEDEC STANDARDS MO-153AB

AD7816/AD7817/AD7818

Revision History

Location	Page
9/04—Data Sheet changed from REV. B to REV. C.	
Updated ORDERING GUIDE	6
Changes to Operating Modes section	13
Changes to Figure 16	13
Changes to Figure 17	14
Changes to AD7817 Serial Interface, Read Operation section	15
Changes to Figure 20	15
Changes to Figure 21	16

