

AD7510DI, AD7511DI, AD7512DI

## FEATURES

- Latch-Proof
- Overvoltage-Proof:  $\pm 25V$
- Low  $R_{ON}$ :  $75\Omega$
- Low Dissipation: 3mW
- TTL/CMOS Direct Interface
- Silicon-Nitride Passivated
- Monolithic Dielectrically-Isolated CMOS

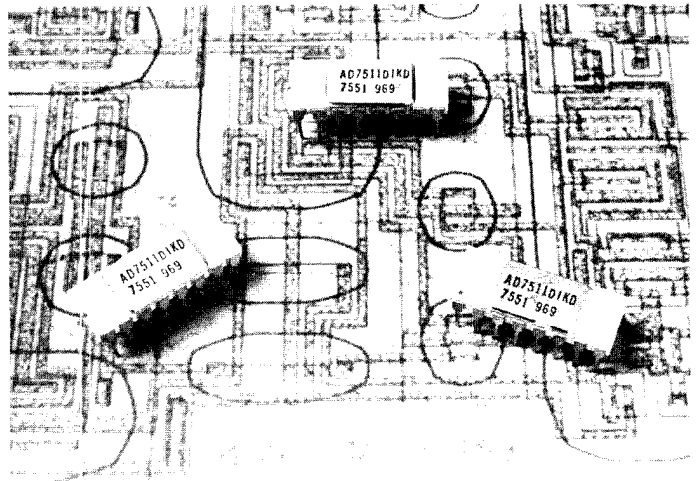

## GENERAL DESCRIPTION

The AD7510DI, AD7511DI and AD7512DI are a family of latch proof dielectrically isolated CMOS switches featuring overvoltage protection up to  $\pm 25V$  above the power supplies. These benefits are obtained without sacrificing the low "ON" resistance ( $75\Omega$ ) or low leakage current ( $400pA$ ), the main features of an analog switch.

The AD7510DI and AD7511DI consist of four independent SPST analog switches packaged in a 16-pin DIP. They differ only in that the digital control logic is inverted. The AD7512DI has two independent SPDT switches packaged in a 14-pin DIP.

Very low power dissipation, overvoltage protection and TTL/CMOS direct interfacing are achieved by combining a unique circuit design and a dielectrically isolated CMOS process. Silicon nitride passivation ensures long term stability while monolithic construction provides reliability.

## PIN CONFIGURATIONS

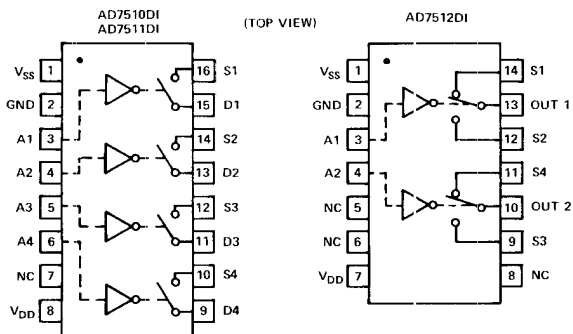

## ORDERING INFORMATION

Plastic (Suffix N)	Ceramic (Suffix D)	Operating Temperature Range
AD7510DIJN AD7510DIKN AD7511DIJN AD7511DIKN AD7512DIJN AD7512DIKN		0 to $+70^{\circ}C$
	AD7510DIJD AD7510DIKD AD7511DIJD AD7511DIKD AD7512DIJD AD7512DIKD	$-25^{\circ}C$ to $+85^{\circ}C$
	AD7510DISD AD7511DISD AD7511DITD AD7512DISD AD7512DITD	$-55^{\circ}C$ to $+125^{\circ}C$

## CONTROL LOGIC

AD7510DI: Switch "ON" for Address "HIGH"

AD7511DI: Switch "ON" for Address "LOW"

AD7512DI: Address "HIGH" makes S1 to Out 1 and S3 to Out 2

# SPECIFICATIONS (V<sub>DD</sub> = +15V, V<sub>SS</sub> = -15V unless otherwise noted)

## COMMERCIAL VERSIONS (J, K)

PARAMETER	MODEL	VERSION	+25°C	0 to +70°C (N) -25°C to +85°C (D)	TEST CONDITIONS
<b>ANALOG SWITCH</b>					
R <sub>ON</sub> <sup>1</sup>	All	J, K	75Ω typ, 100Ω max	175Ω max	-10V ≤ V <sub>D</sub> ≤ +10V
R <sub>ON</sub> vs V <sub>D</sub> (V <sub>S</sub> )	All	J, K	20% typ		I <sub>DS</sub> = 1.0mA
R <sub>ON</sub> Drift	All	J, K	+0.5%/°C typ		V <sub>D</sub> = 0, I <sub>DS</sub> = 1.0mA
R <sub>ON</sub> Match	All	J, K	1% typ		
R <sub>ON</sub> Drift Match	All	J, K	0.01%/°C typ		
I <sub>D</sub> (I <sub>S</sub> ) OFF <sup>1</sup>	All	J, K	0.5nA typ, 5nA max	500nA max	V <sub>D</sub> = -10V, V <sub>S</sub> = +10V and V <sub>D</sub> = +10V, V <sub>S</sub> = -10V
I <sub>D</sub> (I <sub>S</sub> ) ON <sup>2</sup>	All	J, K	10nA max		V <sub>S</sub> = V <sub>D</sub> = +10V V <sub>S</sub> = V <sub>D</sub> = -10V
I <sub>OUT</sub> <sup>1</sup>	AD7512DI	J, K	15nA max	1500nA max	V <sub>S1</sub> = V <sub>OUT</sub> = ±10V, V <sub>S2</sub> = ∓10V and V <sub>S2</sub> = V <sub>OUT</sub> = ±10V, V <sub>S1</sub> = ∓10V
<b>DIGITAL CONTROL</b>					
V <sub>INL</sub> <sup>1</sup>	All	J, K		0.8V max	
V <sub>INH</sub> <sup>1</sup>	All	J		3.0V min	
	All	K		2.4V min	
C <sub>IN</sub>	All	J, K	3pF typ		V <sub>IN</sub> = V <sub>DD</sub> V <sub>IN</sub> = 0
I <sub>INH</sub> <sup>1</sup>	All	J, K	10nA max		
I <sub>INL</sub> <sup>1</sup>	All	J, K	10nA max		
<b>DYNAMIC CHARACTERISTICS</b>					
τ <sub>ON</sub>	AD7510DI	J, K	180ns typ		V <sub>IN</sub> = 0 to +3.0V
	AD7511DI	J, K	350ns typ		
τ <sub>OFF</sub>	AD7510DI	J, K	350ns typ		
	AD7511DI	J, K	180ns typ		
τ <sub>TRANSITION</sub>	AD7512DI	J, K	300ns typ		
C <sub>S</sub> (C <sub>D</sub> ) OFF	All	J, K	8pF typ		V <sub>D</sub> (V <sub>S</sub> ) = 0V
C <sub>S</sub> (C <sub>D</sub> ) ON	All	J, K	17pF typ		
C <sub>DS</sub> (C <sub>S-OUT</sub> )	All	J, K	1pF typ		
C <sub>DD</sub> (C <sub>SS</sub> )	All	J, K	0.5pF typ		
C <sub>OUT</sub>	AD7512DI	J, K	17pF typ		
Q <sub>INJ</sub>	All	J, K	30pC typ		Measured at S or D terminal. C <sub>L</sub> = 1000pF, V <sub>IN</sub> = 0 to 3V, V <sub>D</sub> (V <sub>S</sub> ) = +10V to -10V
<b>POWER SUPPLY</b>					
I <sub>DD1</sub> <sup>1</sup>	All	J, K	500μA max		All digital inputs = V <sub>INH</sub>
I <sub>SS</sub>	All	J, K	100μA max		
I <sub>DD1</sub> <sup>1</sup>	All	J, K	100μA max		All digital inputs = V <sub>INL</sub>
I <sub>SS</sub>	All	J, K	100μA max		

### NOTES:

<sup>1</sup> 100% tested.

<sup>2</sup> Guaranteed, not production tested.

<sup>3</sup> A pullup resistor, typically 1-2kΩ is required to make "J" versions TTL compatible.

Specifications subject to change without notice.

**MILITARY VERSIONS (S, T)**

PARAMETER	MODEL	VERSION	+25°C	-55°C to +125°C	TEST CONDITIONS
<b>ANALOG SWITCH</b>					
$R_{ON}^1$	All	S, T	100Ω max	175Ω max	$-10V \leq V_D \leq +10V$ $I_{DS} = 1mA$
$I_D (I_S)_{OFF}^1$	All	S, T	3nA max	200nA max	$V_D = -10V, V_S = +10V$ and $V_D = +10V, V_S = -10V$
$I_D (I_S)_{ON}^2$	All	S, T	10		$V_S = V_D = +10V$ and $V_S = V_D = -10V$
$I_{OUT}^1$	AD7512DI	S, T	9nA max	600nA max	$V_{S1} = V_{OUT} = \pm 10V$ $V_{S2} = \mp 10V$ and $V_{S2} = V_{OUT} = \pm 10V$ $V_{S1} = \mp 10V$
<b>DIGITAL CONTROL</b>					
$V_{INL}^1$	All	S, T		0.8V max	
$V_{INH}^{1,3}$	AD7510DI	S		2.4V min	
	AD7511DI	T		2.4V min	
	AD7512DI	T		2.4V min	
	AD7511DI	S		3.0V min	
	AD7512DI	S		3.0V min	
$I_{INH}^1$	All	S, T	10nA max		$V_{IN} = V_{DD}$
$I_{INL}$	All	S, T	10nA max		$V_{IN} = 0$
<b>DYNAMIC CHARACTERISTICS</b>					
$t_{ON}^2$	AD7510DI	S, T	1.0μs max		$V_{IN} = 0$ to +3V
	AD7511DI	S, T	1.0μs max		
$t_{OFF}^2$	AD7510DI	S, T	1.0μs max		
	AD7511DI	S, T	1.0μs max		
$t_{TRANSITION}^2$	AD7512DI	S, T	1.0μs max		
<b>POWER SUPPLY</b>					
$I_{DD}^1$	All	S, T		800μA max	All digital inputs = $V_{INH}$
$I_{SS}$	All	S, T		800μA max	
$I_{DD}^1$	All	S, T		500μA max	All digital inputs = $V_{INL}$
$I_{SS}$	All	S, T		500μA max	

**NOTES:**

<sup>1</sup> 100% tested.

<sup>2</sup> Guaranteed, not production tested.

<sup>3</sup> A pullup resistor, typically 1-2kΩ is required to make AD7511DISD and AD7512DISD TTL compatible.

Specifications subject to change without notice.

**ABSOLUTE MAXIMUM RATINGS**

$V_{DD}$ to GND	+17V
$V_{SS}$ to GND	-17V
Overvoltage at $V_D (V_S)$	
(1 second surge)	$V_{DD} + 25V$ or $V_{SS} - 25V$
(Continuous)	$V_{DD} + 20V$ or $V_{SS} - 20V$
Switch Current ( $I_{DS}$ , Continuous)	50mA
Switch Current ( $I_{DS}$ , Surge)	
1ms Duration, 10% Duty Cycle	150mA
Digital Input Voltage Range	0V to $V_{DD}$
Power Dissipation (Package)	
14 & 16 pin Ceramic Dip	
Up to +75°C	450mW
Derates above +75°C by	6mW/°C

14 & 16 pin Plastic Dip	
Up to +70°C	670mW
Derates above +75°C by	8.3mW/°C
Storage Temperature	-65°C to +150°C
Operating Temperature	
Plastic (J, K Versions)	0 to +70°C
Ceramic (J, K Versions)	-25°C to +85°C
Ceramic (S, T Versions)	-55°C to +125°C

**CAUTION:** The digital control inputs are zener protected; however, permanent damage may occur on unconnected units under high electrostatic fields. Keep unused units in conductive foam at all times. Prior to pulling the devices from the conductive foam, ground the foam to deplete any accumulated charge.

## CIRCUIT DESCRIPTION

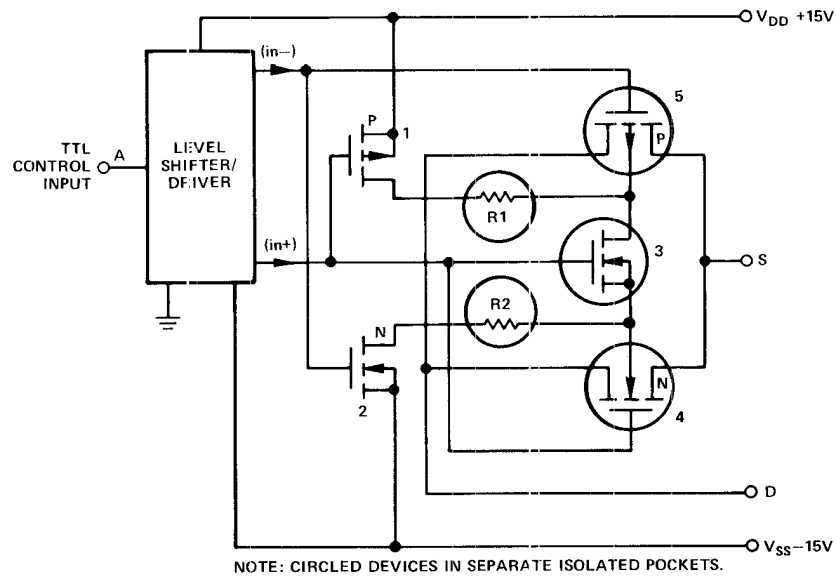

Figure 1. Typical Output Switch Circuitry of AD7510DI Series

CMOS devices make excellent analog switches; however, problems with overvoltage and latch-up phenomenon necessitated protection circuitry. These protection circuits, however, either caused degradation of important switch parameters such as  $R_{ON}$  or leakage, or provided only limited protection in the event of overvoltage.

The AD7510DI series switches utilize a dielectrically-isolated CMOS fabrication process to eliminate the four-layer substrate found in junction-isolated CMOS, thus providing latch-free operation.

A typical switch channel is shown in Figure 1. The output switching element is comprised of device numbers 4 and 5. Operation is as follows: for an "ON" switch, (in+) is  $V_{DD}$  and (in-) is  $V_{SS}$  from the driver circuits. Device numbers 1 and 2 are "OFF" and number 3 is "ON." Hence, the back-gates of the P- and N-channel output devices (numbers 4 and 5) are tied together and floating. (The circled devices are located in separate dielectrically isolated pockets.) Floating the output switch back-gates with the signal input increases the effective threshold voltage for an applied analog signal, thus providing a flatter  $R_{ON}$  versus  $V_S$  response.

For an "OFF" switch, device number 3 is "OFF," and the back-gates of devices 4 and 5 are tied through  $1k\Omega$  resistors (R1 and R2) to the respective supply voltages through the "ON" devices 1 and 2.

If a voltage is applied to the S or D terminal which exceeds  $V_{DD}$  or  $V_{SS}$ , the S- or D-to-back-gate diode is forward biased; however, R1 and R2 provide current limiting action.

Consequently, without external current limiting resistance (or increased  $R_{ON}$ ), the AD7510DI series switches provide:

1. Latch-proof operation
2. Overvoltage protection 25V beyond the  $V_{SS}$  and  $V_{DD}$  supply voltage

An equivalent circuit of the output switch element in Figure 2 shows that, indeed, the  $1k\Omega$  limiting resistors are in series with the back-gates of the P- and N-channel output devices—*not* in series with the signal path between the S and D terminals.

In some applications it is possible to turn on a parasitic NPN (drain to back-gate to source of the N-channel) transistor, causing device destruction under certain conditions. This case will only manifest itself when a negative overvoltage (and not a positive overvoltage) exists with another voltage source on the other side of the switch. Current limitation through external resistors ( $200\Omega$ ) or current limiting devices (output of op amps) will prevent damage to the device.

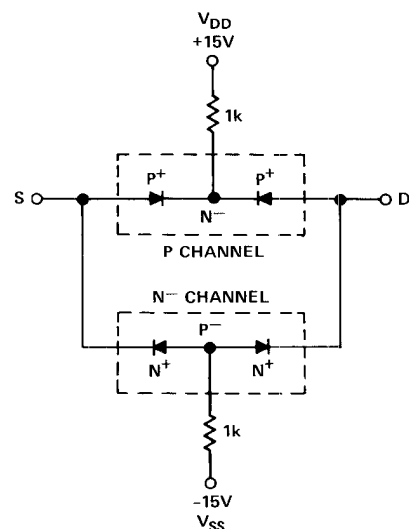
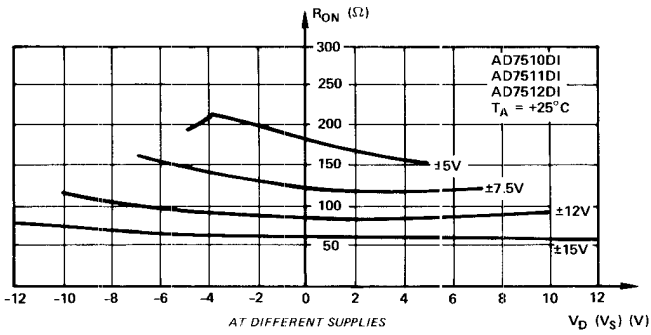
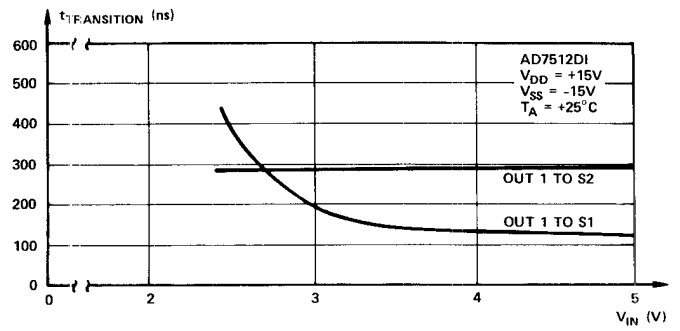

Figure 2. AD7510DI Series Output Switch Diode Equivalent Circuit

# TYPICAL PERFORMANCE CHARACTERISTICS



$R_{ON}$  as a Function of  $V_D$  ( $V_S$ )



$t_{TRANSITION}$  as a Function of Digital Input Voltage

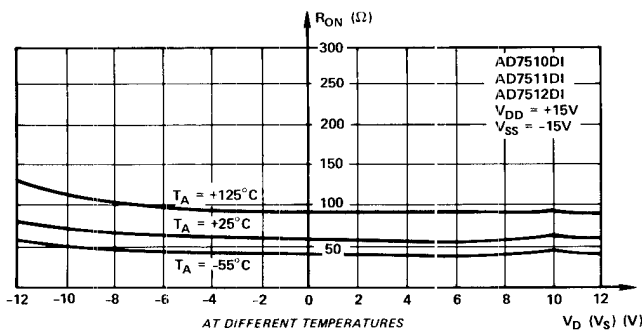

$R_{ON}$  as a Function of  $V_D$  ( $V_S$ )

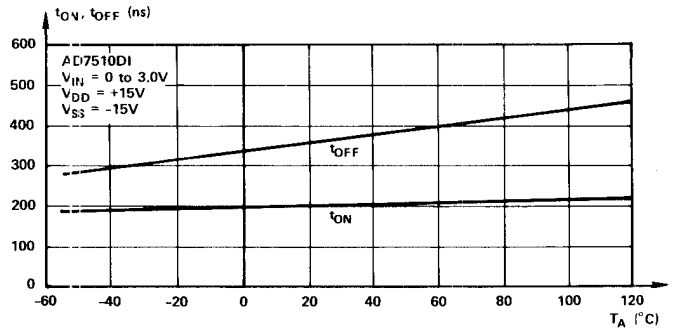

$t_{ON}$ ,  $t_{OFF}$  as a Function of Temperature

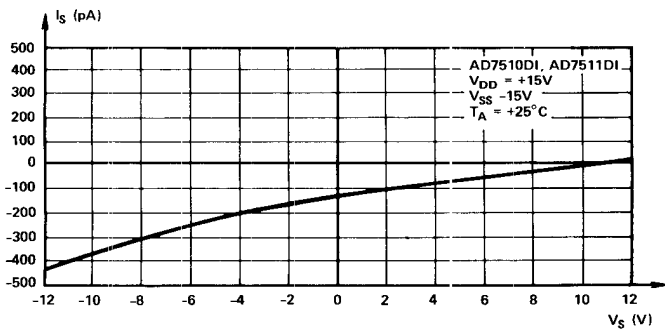

$I_S$  ( $I_{D/OFF}$ ) vs  $V_S$

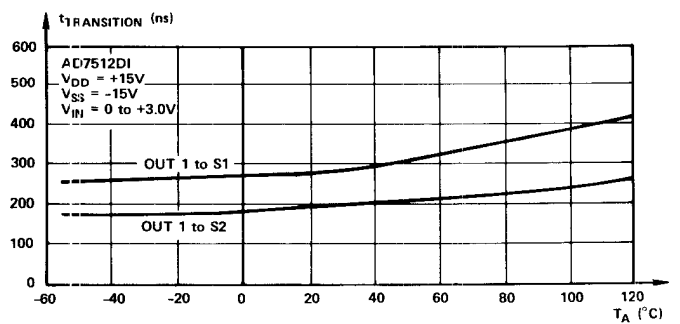

$t_{TRANSITION}$  as a Function of Temperature

TYPICAL SWITCHING CHARACTERISTICS

AD7510DI, AD7511DI

0.5μs/DIV

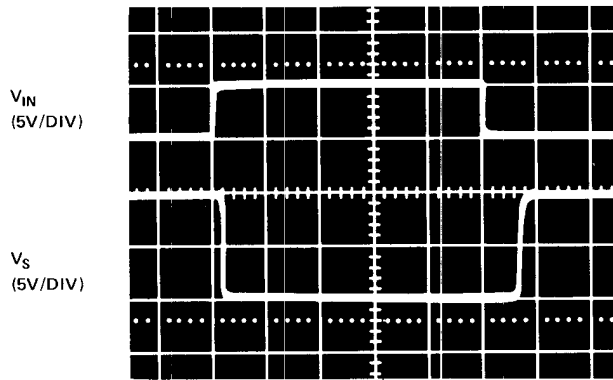

Switching Waveforms for  $V_D = -10V$

0.5μs/DIV

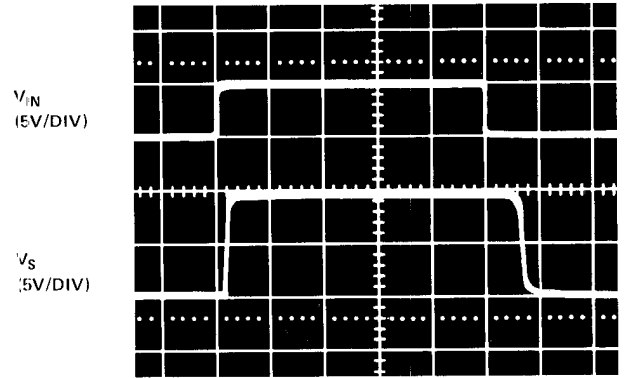

Switching Waveforms for  $V_D = +10V$

0.5μs/DIV

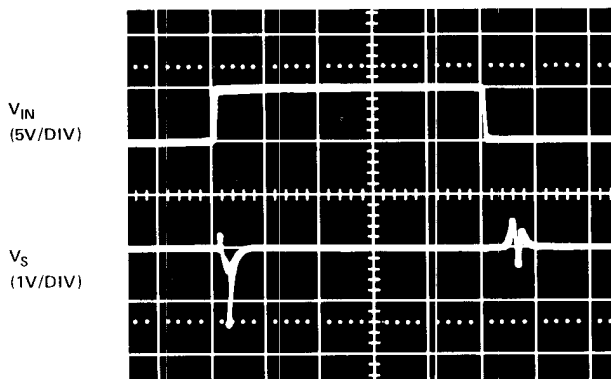

Switching Waveforms for  $V_D = \text{Open}$

0.5μs/DIV

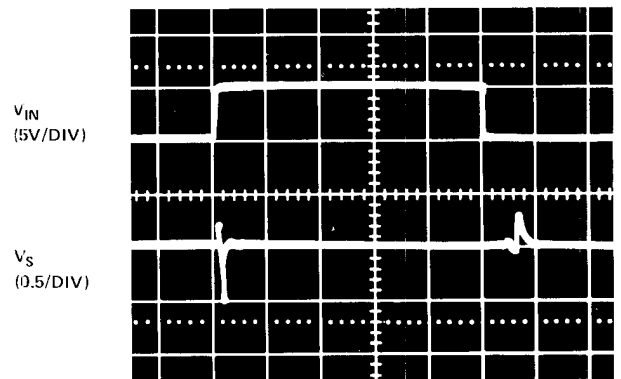

Switching Waveforms for  $V_D = 0V$

AD7510DI, AD7511DI TEST CIRCUIT

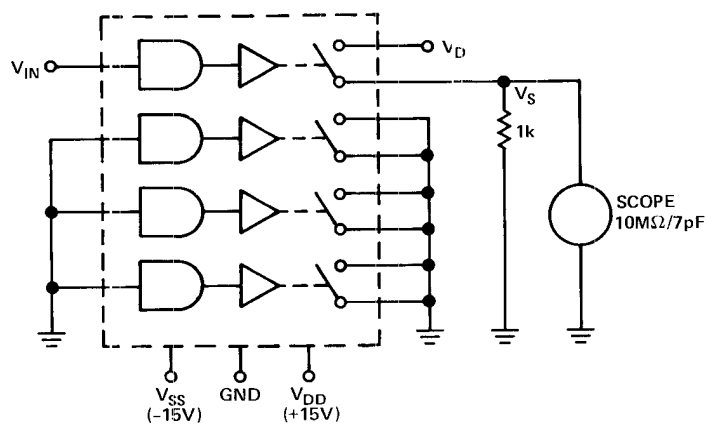

TYPICAL SWITCHING CHARACTERISTICS

AD7512DI

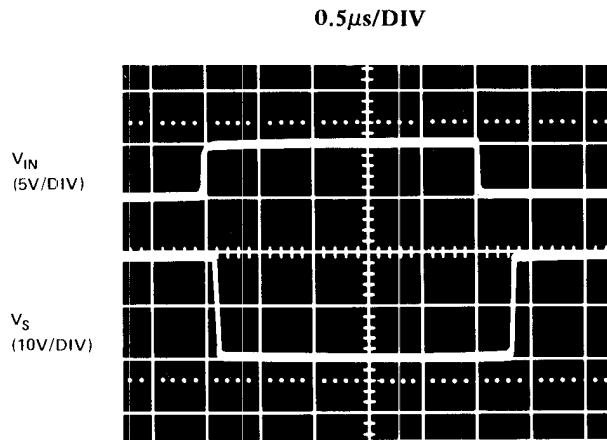

Switching Waveforms for  
 $V_{S1} = -10V, V_{S2} = +10V, R_L = 1k$

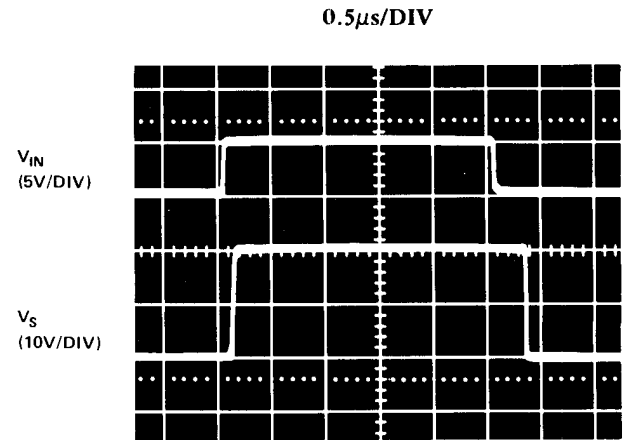

Switching Waveforms for  
 $V_{S1} = +10V, V_{S2} = -10V, R_L = \infty$

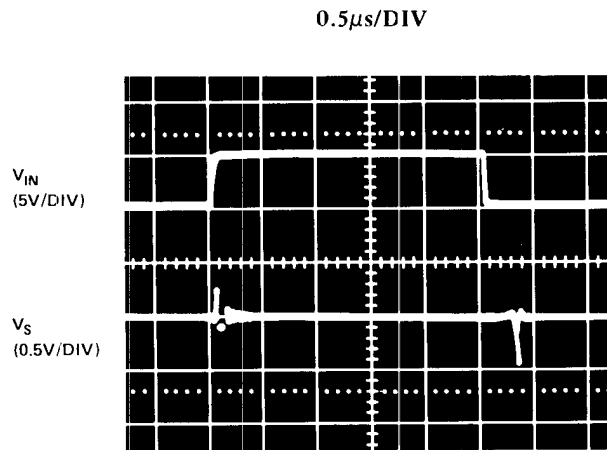

Switching Waveforms for  
 $V_{S1}$  and  $V_{S2} = 0V, R_L = \infty$

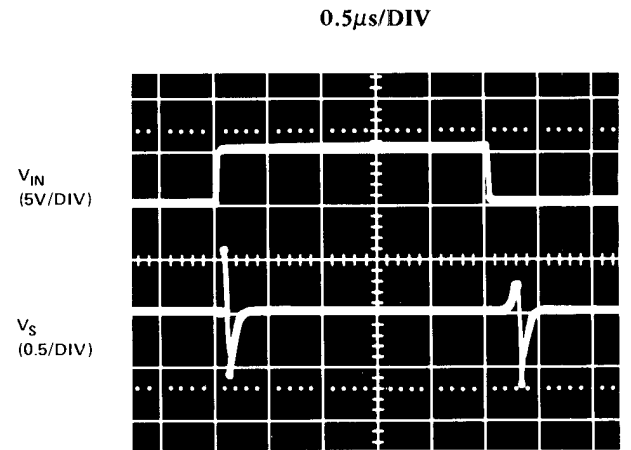

Switching Waveforms for  
 $V_{S1}$  and  $V_{S2} = \text{Open}, R_L = 1k$

AD7512DI TEST CIRCUIT

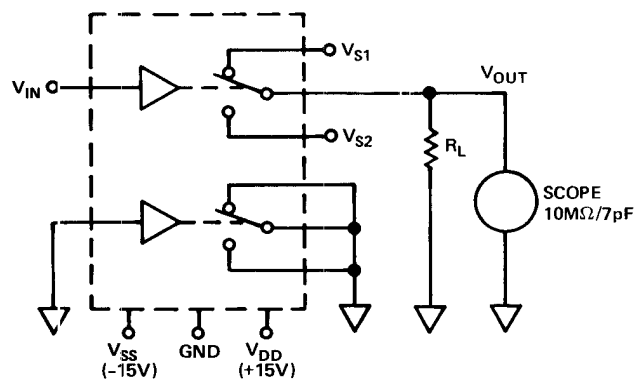

## TERMINOLOGY

$R_{ON}$ :	Ohmic resistance between terminals D and S.
$R_{ON}$ Drift Match:	Difference between the $R_{ON}$ drift of any two switches.
$R_{ON}$ Match:	Difference between the $R_{ON}$ of any two switches.
$I_D (I_S)_{OFF}$ :	Current at terminals D or S. This is a leakage current when the switch is "OFF."
$I_D (I_S)_{ON}$ :	Leakage current that flows from the closed switch into the body. (This leakage will show up as the difference between the current $I_D$ going into the switch and the outgoing current $I_S$ .)
$V_D (V_S)$ :	Analog voltage on terminal D (S).
$C_S (C_D)$ :	Capacitance between terminal S (D) and ground. (This capacitance is specified for the switch open and closed.)
$C_{DS}$ :	Capacitance between terminals D and S. (This will determine the switch isolation over frequency.)
$C_{DD} (C_{SS})$ :	Capacitance between terminals D (S) of any two switches. (This will determine the cross coupling between switches vs. frequency.)
$t_{ON}$ :	Delay time between the 50% points of the digital input and switch "ON" condition.
$t_{OFF}$ :	Delay time between the 50% points of the digital input and switch "OFF" condition.
$t_{transition}$ :	Delay time when switching from one address state to another.
$V_{INL}$ :	Threshold voltage for the low state.
$V_{INH}$ :	Threshold voltage for the high state.
$I_{INL} (I_{INH})$ :	Input current of the digital input.
$C_{IN}$ :	Input capacitance to ground of the digital input.
$V_{DD}$ :	Most positive voltage supply.
$V_{SS}$ :	Most negative voltage supply.
$I_{DD}$ :	Positive supply current.
$I_{SS}$ :	Negative supply current.

## BONDING DIAGRAMS (TOP VIEW)

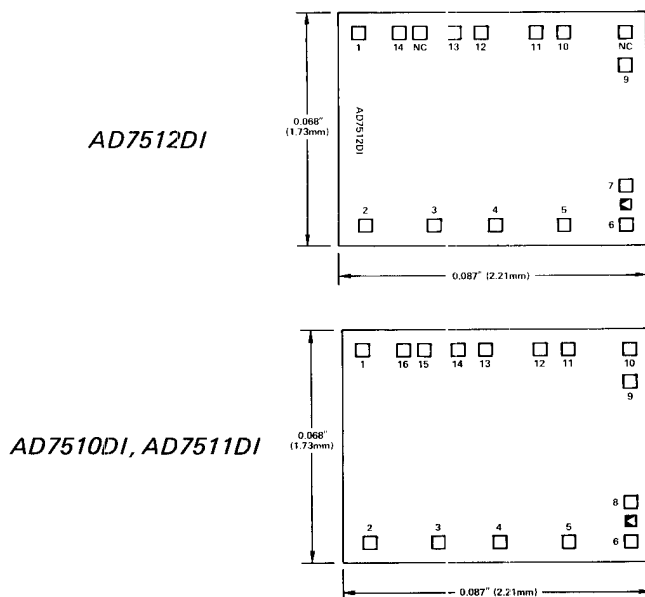

## OUTLINE DIMENSIONS

Dimensions shown in inches and (mm).

### 14-PIN CERAMIC DIP

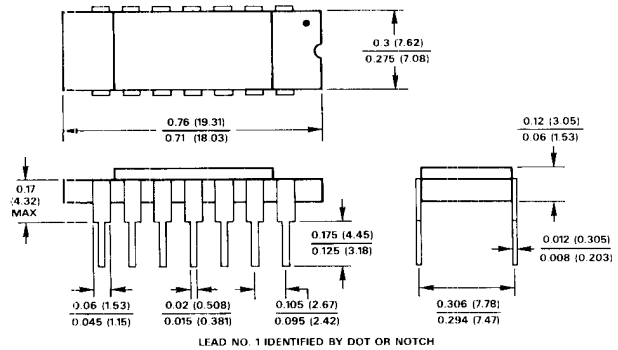

### AD7512DI

### 14-PIN PLASTIC DIP

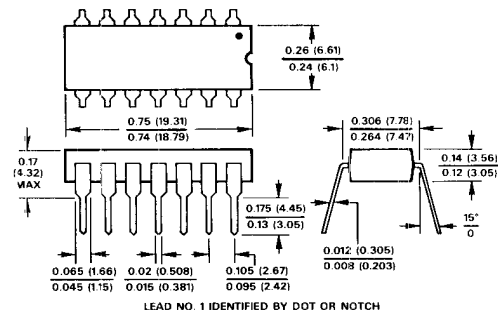

### AD7512DI

### 16-PIN CERAMIC DIP

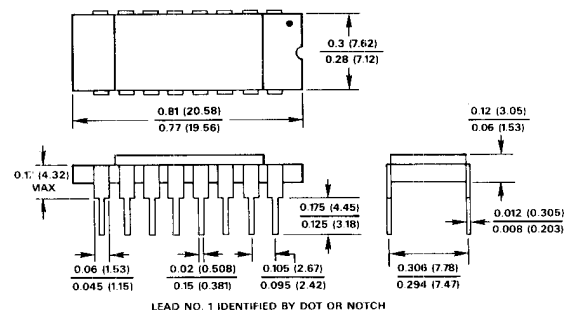

### AD7510DI, AD7511DI

### 16-PIN PLASTIC DIP

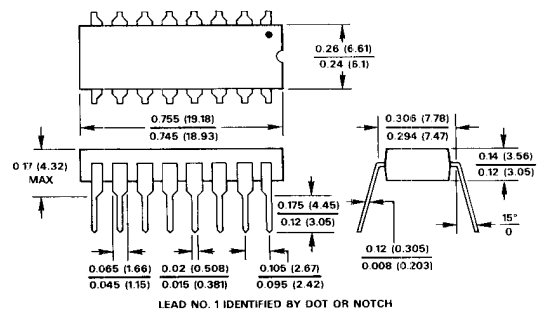

### AD7510DI, AD7511DI