

**Features**

- High speed, low noise non-inverting 1-13 buffer
- Supports up to four SDRAM DIMMs
- Low skew (<250ps) between any two output clocks
- I<sup>2</sup>C Serial Configuration interface
- Multiple V<sub>DD</sub>, V<sub>SS</sub> pins for noise reduction
- 3.3V power supply voltage
- 28-pin SSOP and SOIC packages (H, S)

**Description**

The PI6C184-02 is a high-speed low-noise 1-13 non-inverting buffer designed for SDRAM clock buffer applications.

This buffer is intended to be used with the PI6C104 clock generator for Intel Architecture for both desktop and mobile systems.

At power up all SDRAM output are enabled and active. The I<sup>2</sup>C Serial control may be used to individually activate/deactivate any of the 13 output drivers.

**Note:**

Purchase of I<sup>2</sup>C components from Pericom conveys a license to use them in an I<sup>2</sup>C system as defined by Philips.

**Block Diagram**

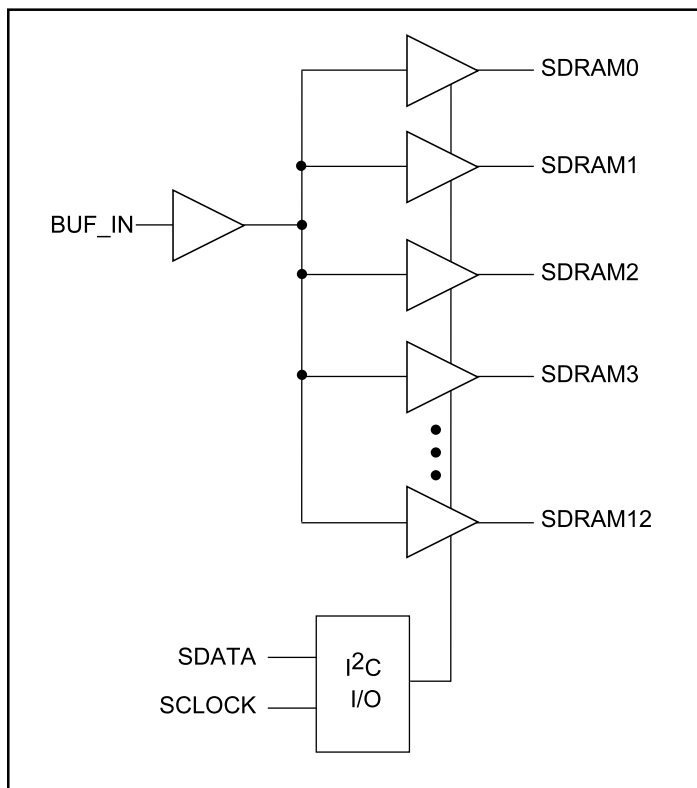

**Pin Configuration**

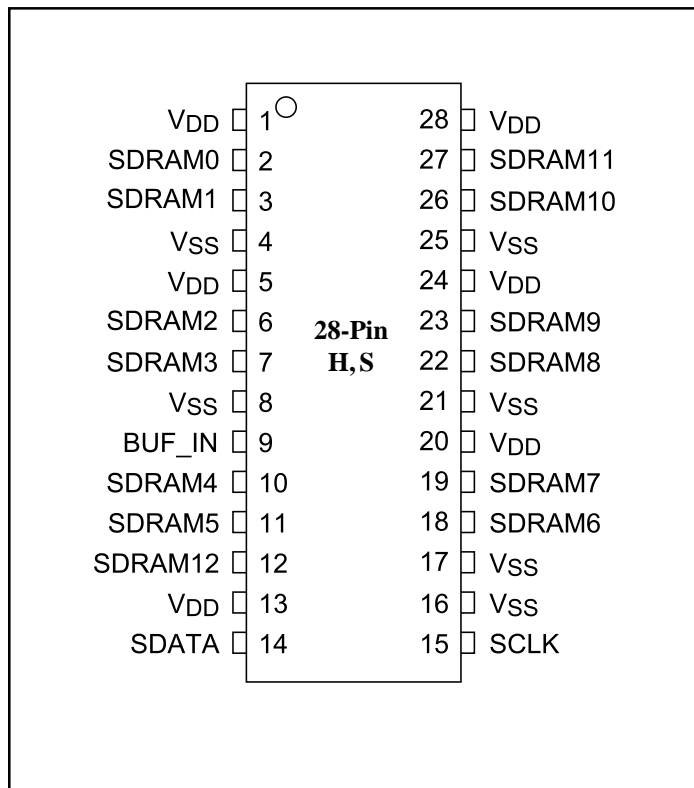

### Pin Description

Pin	Symbol	Type	Quantity	Description
2,3,6,7,10,11,	SDRAM [0.5]	0	6	SDRAM Byte 0 clock output
18,19,22,23,26,27	SDRAM [6.11]	0	6	SDRAM Byte 1 clock output
12	SDRAM [12]	0	1	SDRAM Byte 2 clock output
9	BUF_IN	1	1	Input for 1-13-buffer
14	SDATA	I/O	1	Data pin for I <sup>2</sup> C circuitry. Has a 100k Internal pull-up resistor
154	SCLOCK	I/O	1	Clock pin for I <sup>2</sup> C circuitry. Has a 100k Internal pull-up resistor
1,5,13,20,24,28	V <sub>DD</sub>	Power	6	3.3V power supply for SDRAM buffer
4,8,16,17,21,25	V <sub>SS</sub>	Ground	6	Ground for SDRAM Buffers

### PI6C184-02 I<sup>2</sup>C Address Assignment

A6	A5	A4	A3	A2	A1	A0	R/W
1	1	0	1	0	0	1	0

### PI6C184 Serial Configuration Map

**Byte0: SDRAM Active/Inactive Register**  
(1 = enable, 0 = disable)

Bit	Pin #	Description
Bit 7	11	SDRAM5 (Active/Inactive)
Bit 6	10	SDRAM4(Active/Inactive)
Bit 5	~	Reserved
Bit 4	~	Reserved
Bit 3	7	SDRAM3 (Active/Inactive)
Bit 2	6	SDRAM2 (Active/Inactive)
Bit 1	3	SDRAM1 (Active/Inactive)
Bit 0	2	SDRAM0 (Active/Inactive)

**Note:**

Inactive means outputs are held LOW and are disabled from switching

## 2-Wire I<sup>2</sup>C Control

The I<sup>2</sup>C interface permits individual enable/disable of each clock output and test mode enable.

The PI6C184-02 is a slave receiver device. It can not be read back. Sub addressing is not supported. All preceding bytes must be sent in order to change one of the control bytes.

Every bite put on the SDATA line must be 8-bits long (MSB first), followed by an acknowledge bit generated by the receiving device.

During normal data transfers Sdata changes only when SCLK is LOW. Exceptions: A HIGH to LOW transition on SDATA while SCLK is HIGH indicates a “start” condition. A LOW to HIGH transition on SDATA while SCLK is HIGH is a “stop” condition and indicates the end of a data transfer cycle.

Each data transfer is initiated with a start condition and ended with a stop condition. The first byte after a start condition is always a 7-bit address byte followed by a read/write bit. (HIGH = read from addressed device, LOW = write to addressed device). If the device’s own address is detected, PI6C184-02 generates an acknowledge by pulling SDATA line LOW during ninth clock pulse, then accepts the following data bytes until another start or stop condition is detected.

Following acknowledgement of the address byte (D2), two more bytes must be sent:

1. “Command Code” byte, and
2. “Byte Count” byte.

Although the data bits on these two bytes are “don’t care,” they must be sent and acknowledged.

### Byte1: SDRAM Active/Inactive Register (1 = enable, 0 = disable)

Bit	Pin #	Description
Bit 7	27	SDRAM11 (Active/Inactive)
Bit 6	26	SDRAM10 (Active/Inactive)
Bit 5	23	SDRAM9 (Active/Inactive)
Bit 4	22	SDRAM8 (Active/Inactive)
Bit 3	N/A	(Reserved)
Bit 2	N/A	(Reserved)
Bit 1	19	SDRAM7 (Active/Inactive)
Bit 0	18	SDRAM6 (Active/Inactive)

### Byte2: Optional Register for Possible Future Requirements (1 = enable, 0 = disable)

Bit	Pin #	Description
Bit 7	N/A	(Reserved)
Bit 6	12	SDRAM12 (Active/Inactive)
Bit 5	N/A	(Reserved)
Bit 4	N/A	(Reserved)
Bit 3	N/A	(Reserved)
Bit 2	N/A	(Reserved)
Bit 1	N/A	(Reserved)
Bit 0	N/A	(Reserved)

## Maximum Ratings

(Above which the useful life may be impaired. For user guidelines, not tested.)

Storage Temperature .....	-65°C to +150°C
Ambient Temperature with Power Applied .....	-0°C to +70°C
3.3V Supply Voltage to Ground Potential .....	-0.5V to +4.6V
DC Input Voltage .....	-0.5V to +4.6V

**Note:**

Stresses greater than those listed under MAXIMUM RATINGS may cause permanent damage to the device. This is a stress rating only and functional operation of the device at these or any other conditions above those indicated in the operational sections of this specification is not implied. Exposure to absolute maximum rating conditions for extended periods may affect reliability.

## Supply Current (V<sub>DD</sub> = +3.465V, Load = max)

Symbol	Parameter	Test Condition	Min.	Typ.	Max	Units
I <sub>DD</sub>	Supply Current	BUF_IN = 0 MHz			3	mA
I <sub>DD</sub>	Supply Current	BUF_IN = 66.66 MHz			230	
I <sub>DD</sub>	Supply Current	BUF_IN = 100.0 MHz			360	

**DC Operating Specifications ( $V_{DD} = +3.3V \pm 5\%$ ,  $T_A = 0^\circ C - 70^\circ C$ )**

Symbol	Parameter	Test Condition	Min.	Max.	Units
<b>Input Voltage, <math>V_{DDCORE} [0-1] = 3.3V \pm 5\%</math></b>					
$V_{IH}$	Input High Voltage	$V_{DD}$	2.0	$V_{DDCORE} + 0.3$	V
$V_{IL}$	Input Low Voltage		$V_{SS} - 0.3$	0.8	
$I_{IL}$	Input Leakage Current	$0 < V_{IN} < V_{DD}$	-5	+5	
<b><math>V_{DD} = 3.3V \pm 5\%</math></b>					
$V_{OH}$	Output High Voltage	$I_{OH} = -1mA$	2.4		V
$V_{OL}$	Output Low Voltage	$I_{OL} = -1mA$		0.4	
$C_{IN}$	Input Pin Capacitance			5	pF
$C_{OUT}$	Output pins Capacitance			6	
$L_{PIN}$	Pin Inductance			7	nH
$T_A$	Ambient Temperature	No Airflow	0	70	$^\circ C$

**SDRAM Clock Buffer Operating Specification**

Symbol	Parameter	Condition	Min.	Typ.	Max.	Units
$I_{OHMIN}$	Pull-up current	$V_{OUT} = 2.0V$	-54			mA
$I_{OHMAX}$	Pull-up current	$V_{OUT} = 3.135V$			-46	
$I_{OLMIN}$	Pull-down current	$V_{OUT} = 1.0V$	54			
$I_{OLMAX}$	Pull-down current	$V_{OUT} = 0.4V$			53	
$t_{RHSDRAM}$	Output rise edge rate SDRAM only	$3.3V \pm 5\%$ @04V-2.4V	1.5		4	V/ns
$t_{FHSDRAM}$	Output fall edge rate SDRAM only	$3.3V \pm 5\%$ @2.4V-0.4V	1.5		4	

**AC Timing**

Symbol	Parameter	66 MHz		100 MHz		Units
		Min.	Max.	Min.	Max.	
$t_{SDKP}$	SDRAM CLK period	15.0	15.5	10.0	10.5	ns
$t_{SDKH}$	SDRAM CLK high time	5.6		3.3		
$t_{SDKL}$	SDRAM CLK low time	5.3		3.1		
$t_{SDRISE}$	SDRAM CLK rise time	1.5	4.0	1.5	4.0	V/ns
$t_{SDFALL}$	SDRAM CLK fall time	1.5	4.0	1.5	4.0	
$t_{pLH}$	SDRAM Buffer LH prop delay	1.0	5.0	1.0	5.0	ns
$t_{pHL}$	SDRAM Buffer HL prop delay	1.0	5.0	1.0	5.0	
$t_{pZL}, t_{pZH}$	SDRAM Buffer Enable delay	1.0	8.0	1.0	8.0	
$t_{pLZ}, t_{pHZ}$	SDRAM Buffer Disable delay	1.0	8.0	1.0	8.0	
Duty Cycle	Measured at 1.5V	45	55	45	55	%
$t_{SDSKW}$	SDRAM Output to Output Skew		250		250	ps

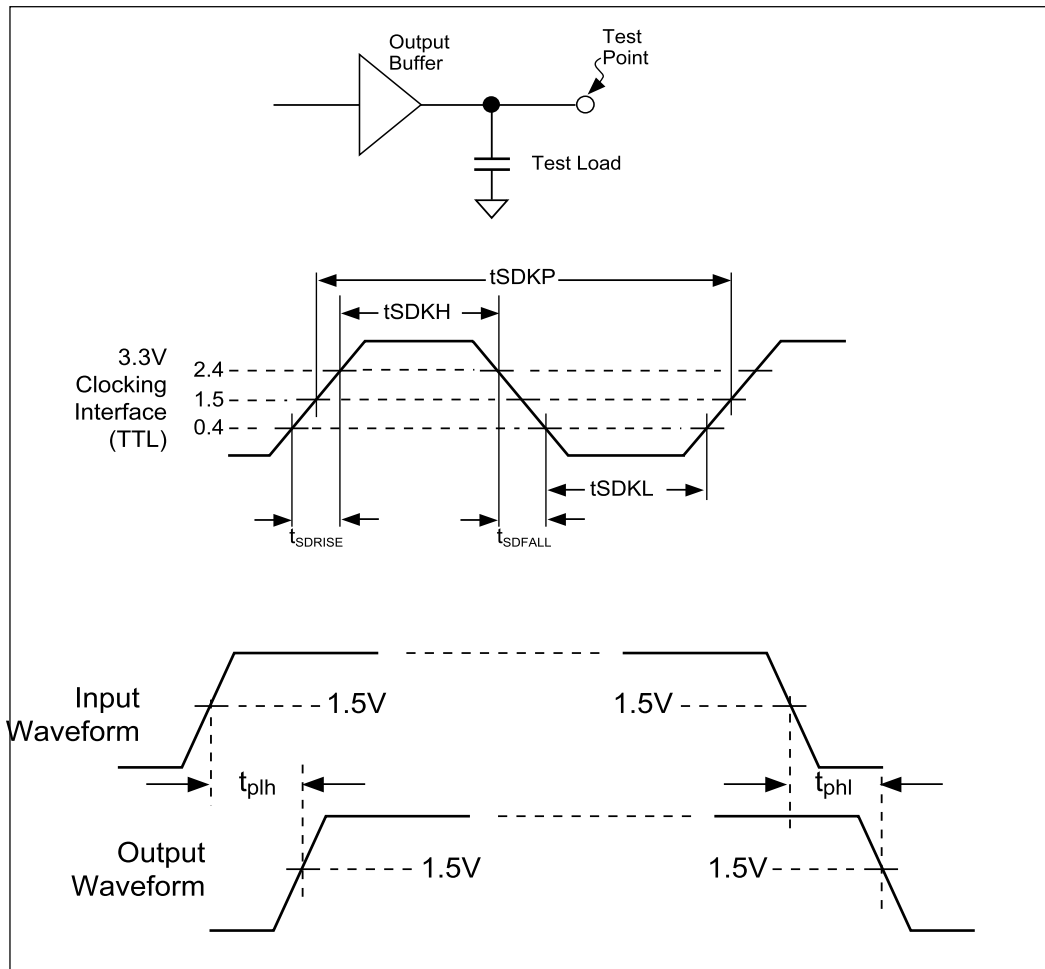

Figure 1. Clock Waveforms

### Minimum and Maximum Expected Capacitive Loads

Clock	Min Load	Max Load	Units	Notes
SDRAM	20	30	pF	SDRAM DIMM Specification

#### Notes:

1. Maximum rise/fall times are guaranteed at maximum specified load.
2. Minimum rise/fall times are guaranteed at minimum specified load.
3. Rise/fall times are specified with pure capacitive load as shown. Testing is done with an additional 500Ω resistor in parallel.

### Design Guidelines to Reduce EMI

1. Place series resistors and CI capacitors as close as possible to the respective clock pins. Typical value for CI is 10 pF. Series resistor value can be increased to reduce EMI provided that the rise and fall time are still within the specified values.
2. Minimize the number of “vias” of the clock traces.
3. Route clock traces over a continuous ground plane or over a continuous power plane. Avoid routing clock traces from plane to plane (refer to rule #2).
4. Position clock signals away from signals that go to any cables or any external connectors.

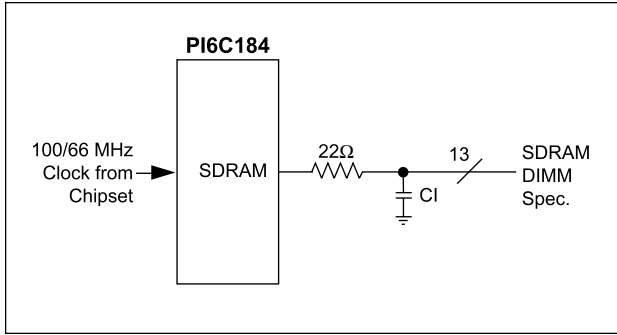
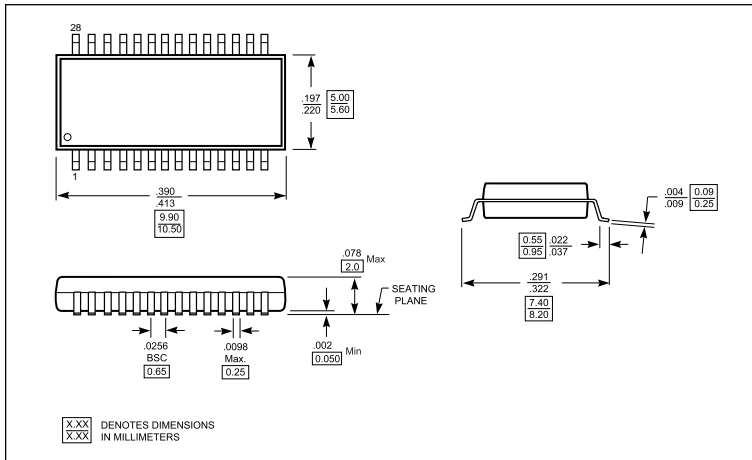
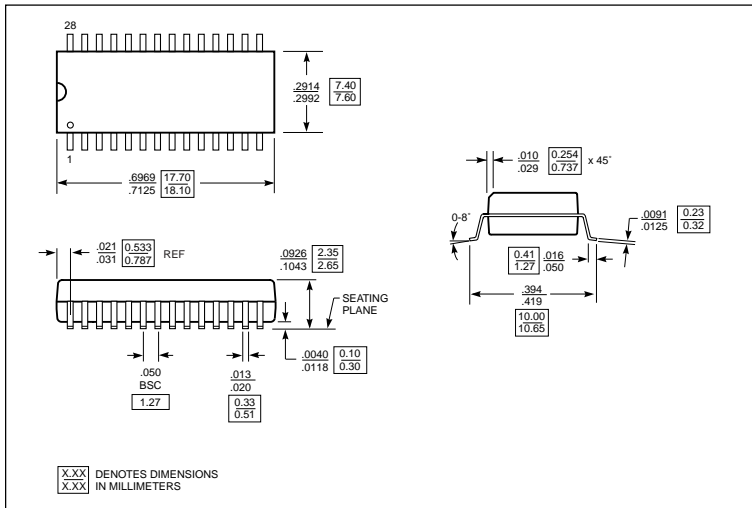

Figure 2. Design Guidelines

### 28-pin SSOP (H)



### 28-pin SOIC (S)



### Ordering Information

P/N	Description
PI6C184-02H	28-pin SSOP Package
PI6C184-02S	28-pin SOIC Package

Pericom Semiconductor Corporation

2380 Bering Drive • San Jose, CA 95131 • 1-800-435-2336 • Fax (408) 435-1100 • <http://www.pericom.com>