

TOSHIBA BIPOLAR LINEAR INTEGRATED CIRCUIT SILICON MONOLITHIC

TA8155F, TA8155FN

REC / PB SYSTEM DUAL PRE-AMPLIFIER (1.5 / 3V USE)

The TA8155F and TA8155FN are REC/PB system dual pre amplifier ICs, which are developed for low voltage operation (1.5/3V use). These are especially suitable for a stereo headphone cassette player.

FEATURES

- Built-in dual playback amplifiers.
Input coupling condenser-less.
Built-in capacitor for buzz noise.
- Built-in dual buffer amplifiers.
For radio signal input.
Monitor for REC mode.
- Built-in dual microphone amplifiers.
Built-in an ALC circuit for MIC-REC mode.
(Attack time. : 0.1s (Typ.)
Recovery time. : 3.5s (Typ.)
- Built-in dual recording amplifiers.
Single-end output type.
- Built-in a power switch.
- Low quiescent current. ($V_{CC} = 1.2V$, $T_a = 25^\circ C$)
PB mode $I_{CCQ2} = 2.6mA$ (Typ.)
RADIO mode $I_{CCQ3} = 2.4mA$ (Typ.)
RADIO-REC mode .. $I_{CCQ4} = 3.0mA$ (Typ.)
MIC-REC mode $I_{CCQ5} = 4.5mA$ (Typ.)
- Low power dissipation.
PB mode : 2.9mW (Typ.)
MIC-REC mode : 8.9mW (Typ.)
- Operating supply voltage range. ($T_a = 25^\circ C$)
 $V_{CC}(\text{opr}) = 0.9\sim 4V$
 $V_{CC}(\text{opr})(\text{REC}) = 1.8\sim 4V$

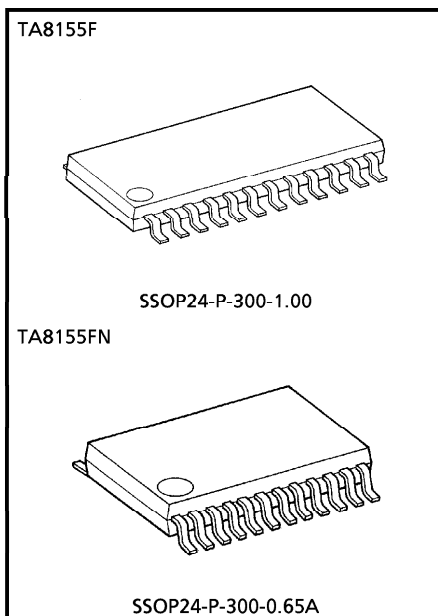

Weight	
SSOP24-P-300-1.00	: 0.32g (Typ.)
SSOP24-P-300-0.65A	: 0.14g (Typ.)

961001EBA2

● TOSHIBA is continually working to improve the quality and the reliability of its products. Nevertheless, semiconductor devices in general can malfunction or fail due to their inherent electrical sensitivity and vulnerability to physical stress. It is the responsibility of the buyer, when utilizing TOSHIBA products, to observe standards of safety, and to avoid situations in which a malfunction or failure of a TOSHIBA product could cause loss of human life, bodily injury or damage to property. In developing your designs, please ensure that TOSHIBA products are used within specified operating ranges as set forth in the most recent products specifications. Also, please keep in mind the precautions and conditions set forth in the TOSHIBA Semiconductor Reliability Handbook.

BLOCK DIAGRAM

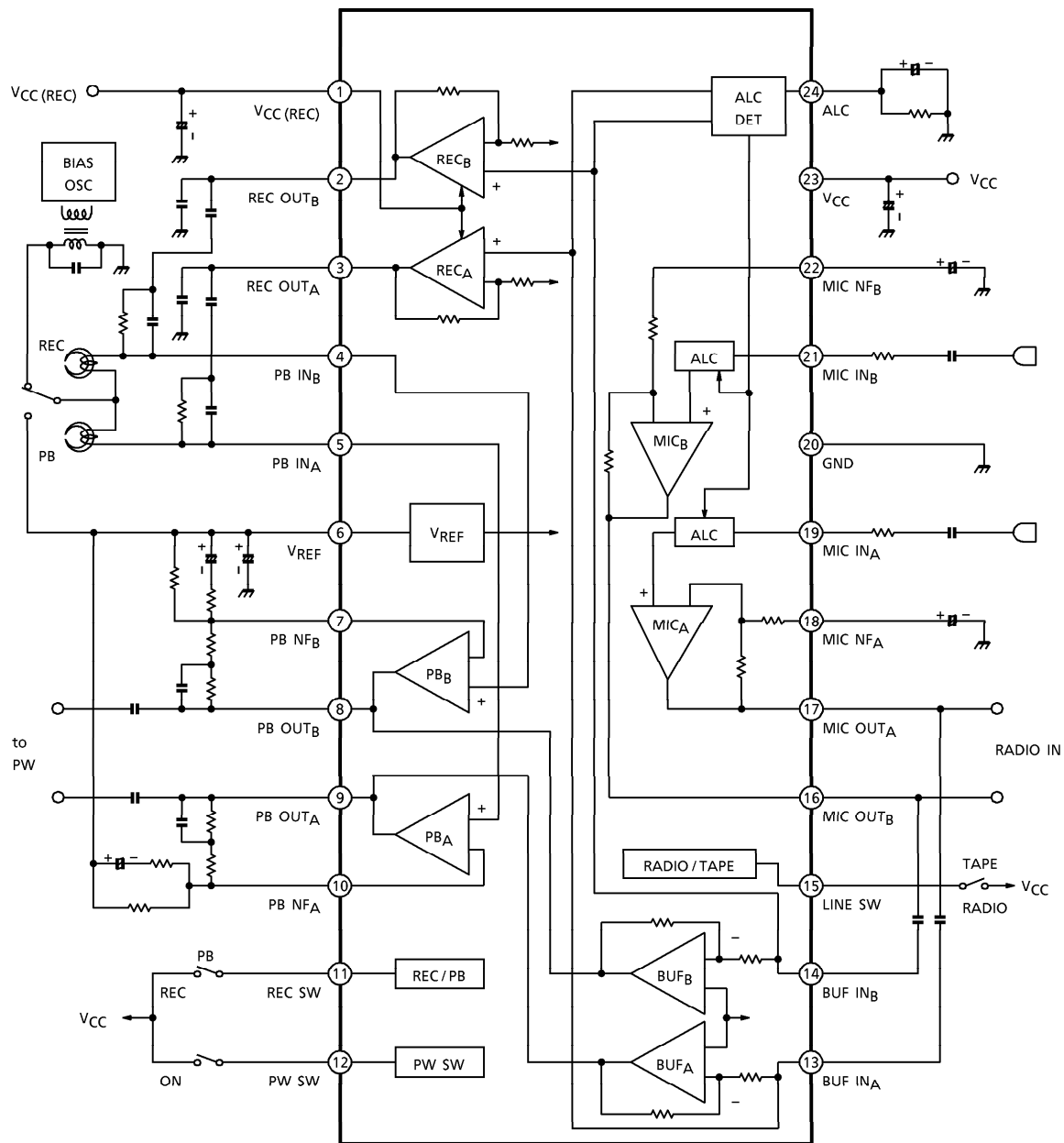

961001EBA2'

- The products described in this document are subject to foreign exchange and foreign trade control laws.
- The information contained herein is presented only as a guide for the applications of our products. No responsibility is assumed by TOSHIBA CORPORATION for any infringements of intellectual property or other rights of the third parties which may result from its use. No license is granted by implication or otherwise under any intellectual property or other rights of TOSHIBA CORPORATION or others.
- The information contained herein is subject to change without notice.

TERMINAL EXPLANATION

Terminal voltage : Typical terminal voltage at no signal with test circuit.
 (V_{CC} = 1.2V, V_{CC}(REC) = 2.4V, T_a = 25°C)

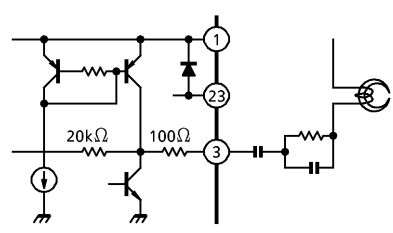
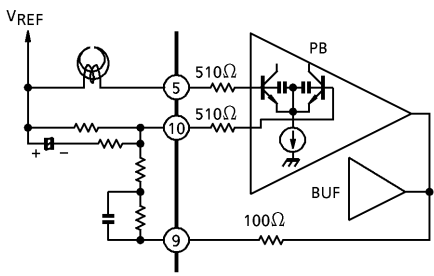
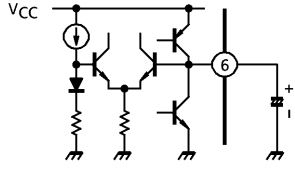
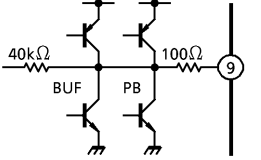
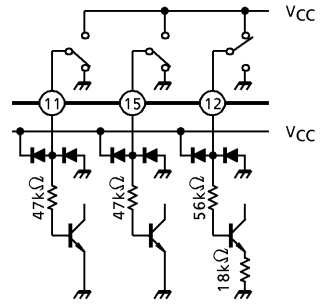
TERMINAL		FUNCTION	INTERNAL CIRCUIT	TERMINAL VOLTAGE (V)	
No.	NAME				
1	V _{CC} (REC)	This terminal voltage supplies output stage of recording amplifier with power source.		2.4	
2	REC OUT _B			Output of recording amplifier.	1.15
3	REC OUT _A				
4	PB IN _B	Input of playback amplifier.		0.85	
5	PB IN _A				
7	PB NF _B	NF of playback amplifier.		0.85	
10	PB NF _A				
6	V _{REF}	Reference voltage. All amplifier operate on this voltage.		0.85	
8	PB OUT _B	Output of playback amplifier and buffer amplifier.		0.55	
9	PB OUT _A				
11	REC SW	REC / PB switch. (V _{CC} : REC mode. GND / OPEN : PB mode.		—	
12	PW SW	Power switch. (V _{CC} : Power on. GND / OPEN : Power off.		—	
15	LINE SW	Line switch. (V _{CC} : BUF (Radio) mode. GND / OPEN : Tape mode.		—	

TERMINAL		FUNCTION	INTERNAL CIRCUIT	TERMINAL VOLTAGE (V)
No.	NAME			
13	BUF IN _A	Input of buffer amplifier and recording amplifier. (Buffer amplifier is inverter type.) ALC level of microphone amplifier is determined by signal level of this terminal		0.85
14	BUF IN _B			
16	MIC OUT _B	Output of microphone amplifier.		0.55
17	MIC OUT _A			
18	MIC NF _A	NF of microphone amplifier.		0.05
22	MIC NF _B			
19	MIC IN _A	Input of microphone amplifier. Built-in capacitor for buzz noise.		0.01
21	MIC IN _B			
20	GND	—	—	0
23	V _{CC}	—	—	1.2
24	ALC	ALC terminal. ALC function is operated in only MIC-REC mode.		0.11

APPLICATION NOTE

(1) PW SW

It is necessary to connect an external pull-down resistor with the terminal PW SW (pin⑫), in case that this IC is turned on due to external noise etc.

(2) MODE SW

IC mode is determined by switch condition of REC SW (pin⑪) and LINE SW (pin⑮) (Table.1).

Table.1 IC mode

REC SW \ LINE SW	L	H
L	PB mode (PB)	MIC-REC (BUF, MIC, REC)
H	RADIO mode (BUF)	RADIO-REC mode (BUF, REC)

() : Operating amplifier.

- H level : Bias current should be applied to switch terminal more than 5μA.
- L level : Bias voltage should be applied to switch terminal from 0V to 0.3V.

The leak current flows through the terminal of REC SW (pin⑪) or LINE SW (pin⑮), in case that the terminals connected with V_{CC} line independently, even though this IC is off-mode (the terminal of PW SW (pin⑫) is off-mode).

And it is necessary to connect an external pull-down resistor with the terminal REC SW (pin⑪) and LINE SW (pin⑮), in case that this IC is turned on due to external noise etc.

(3) PLAYBACK AMPLIFIER

Output voltage of playback amplifier is determined by an external resistor R₁ and R_f.

$$V_O (PRE) = V_{REF} - \Delta V - R_f \left(\frac{\Delta V}{R_1} - I_B (NF) \right)$$

ΔV is an off-set voltage which is designed to 18mV.

In case that β of transistor is assumed 100, I_B (NF) is flowed 0.2μA in Fig.1. And output voltage of playback amplifier (pin⑧, ⑨) in Fig.1 is

$$V_O (PRE) = 0.85V - 0.018V - (330k\Omega + 13k\Omega)$$

$$\times \left(\frac{0.018V}{18k\Omega} - 0.2\mu A \right) = 0.56 (V)$$

Output voltage of playback amplifier should be fixed V_{CC}/2, because playback amplifier get a enough dynamic range.

And current source of 20μA is operated except playback mode, in order to reduce a pop sound in switchover between playback on / off mode (Fig.2).

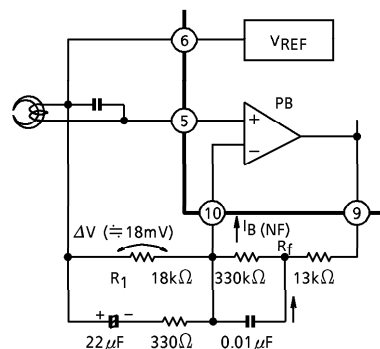

Fig.1 DC output voltage of playback amplifier.

(4) MICROPHONE AMPLIFIER

Current source of $5.5\mu A$ is operated except MIC-REC mode, because bias is applied to the same output voltage as output voltage of microphone amplifier in operation (Fig.3).

(5) $V_{CC(REC)}$

The $V_{CC(REC)}$ terminal (pin①) is applied bias to $V_{CC(REC)} = V_{CC} - 0.7V$, because the $V_{CC(REC)}$ terminal (pin①) is connected with the V_{CC} terminal (pin⑬) by diode, as internal circuit of terminal explanation.

And supply current doesn't flow through $V_{CC(REC)}$ terminal (pin①), in case that the terminal is connected with V_{CC} line, even though this IC is on-mode and except REC mode.

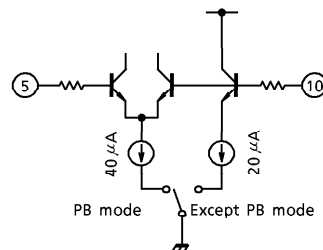

Fig.2 Reducing a pop sound of mode switchover (1).

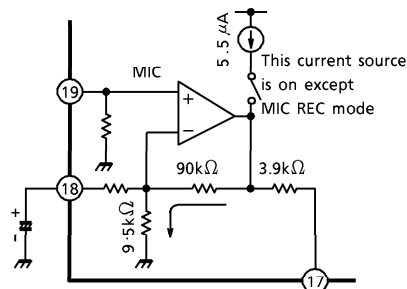

Fig.3 Reducing a pop sound of mode switchover (2).

MAXIMUM RATINGS (Ta = 25°C)

CHARACTERISTIC	SYMBOL	RATING	UNIT
Supply Voltage	V_{CC}	4.5	V
	$V_{CC(REC)}$	4.5	
Power Dissipation	P_D (Note)	400	mW
		500	
Operating Temperature	T_{opr}	- 25~75	°C
Storage Temperature	T_{stg}	- 55~150	°C

(Note) Derated above Ta = 25°C in the proportion of 3.2mW/°C for TA8155F, and of 4mW/°C for TA8155FN.

ELECTRICAL CHARACTERISTICS

Unless otherwise specified : $V_{CC} = 1.2V$, $V_{CC(REC)} = 2.4V$, $f = 1kHz$, $T_a = 25^\circ C$, $SW_1 : a$, $SW_8 : open$
 $SW_9 : on$, $SW_{10} : on$, $SW_{11} : on$, $SW_2 \sim SW_7$ condition by next page

CHARACTERISTIC		SYMBOL	TEST CIRCUIT	TEST CONDITION	MIN.	TYP.	MAX.	UNIT
Quiescent Current	PW OFF	I_{CCO1}	—	$SW_1 : b, SW_2 : b, SW_3 : b$	—	0.1	5	μA
	PB	I_{CCO2}		$SW_2 : b, SW_3 : b$	—	2.6	3.9	mA
	RADIO	I_{CCO3}		$SW_2 : b, SW_3 : a$	—	2.4	3.6	
	RADIO-REC	I_{CCO4}		$SW_2 : a, SW_3 : a$	—	3.0	4.5	
	MIC-REC	I_{CCO5}		$SW_2 : a, SW_3 : b$	—	4.5	6.5	
	$V_{CC(REC)}$	I_{CCO6}		$SW_2 : a, SW_3 : b$	1.3	1.5	2.4	
Reference Voltage		V_{REF}	—		0.8	0.85	0.9	V
Playback Amplifier	Open Loop Voltage Gain	G_{VO}	—	$SW_8 : on, SW_9 : open$ $V_O = -17dBV$	58	70	—	dB
	Closed Loop Voltage Gain	G_{VC}	—	$V_O = -17dBV$	—	36	—	
	Maximum Output Voltage	V_{om1}	—	THD = 1%	200	310	—	mV_{rms}
	Total Harmonic Distortion	THD1	—	$V_O = -17dBV$	—	0.1	0.3	%
	Equivalent Input Noise Voltage	V_{ni}	—	$SW_4 : open$ BPF = 30Hz~20kHz NAB ($G_V = 36dB$, $f = 1kHz$)	—	1.2	3.0	μV_{rms}
	Cross Talk (CH-A / CH-B)	CT1	—	$V_O = -17dBV$	—	62	—	dB
	Ripple Rejection Ratio	RR1	—	$SW_4 : open, SW_{10} : open$ $f_r = 100Hz, V_r = -32dBV$	—	40	—	
Buffer Amplifier	Voltage Gain	G_{V2}	—	$V_O = -17dBV$	-4	-2	0	dB
	Maximum Output Voltage	V_{om2}	—	THD = 1%	200	270	—	mV_{rms}
	Total Harmonic Distortion	THD2	—	$V_O = -17dBV$	—	0.1	—	%
	Output Noise Voltage	V_{no2}	—	$SW_5 : b, BPF = 30Hz \sim 20kHz$	—	35	—	μV_{rms}
	Cross Talk (CH-A / CH-B)	CT2	—	$V_O = -17dBV$	—	51	—	dB
	Ripple Rejection Ratio	RR2	—	$SW_5 : b, SW_{10} : open$ $f_r = 100Hz, V_r = -32dBV$	—	55	—	
Recording Amplifier	Voltage Gain	G_{V3}	—	$V_O = -12dBV$	16.5	18.5	20.5	dB
	Maximum Output Voltage	V_{om3}	—	THD = 1%	500	720	—	mV_{rms}
	Total Harmonic Distortion	THD3	—	$V_O = -12dBV$	—	0.1	0.5	%
	Output Noise Voltage	V_{no3}	—	$SW_5 : b, BPF = 30Hz \sim 20kHz$	—	0.09	0.25	mV_{rms}
	Cross Talk (CH-A / CH-B)	CT3	—	$V_O = -12dBV$	—	49	—	dB
	Ripple Rejection Ratio	RR3	—	$SW_5 : b, SW_{10} : open$ $f_r = 100Hz, V_r = -32dBV$	—	40	—	

CHARACTERISTIC		SYMBOL	TEST CIRCUIT	TEST CONDITION	MIN.	TYP.	MAX.	UNIT
Microphone Amplifier	Voltage Gain	G _{V4}	—	V _O = -17dBV	30	32.5	35	dB
	Maximum Output Voltage	V _{om4}	—	THD = 1%	120	200	—	mV _{rms}
	Total Harmonic Distortion	THD4	—	V _O = -17dBV	—	0.25	0.8	%
	Output Noise Voltage	V _{no4}	—	SW ₆ : a, BPF = 30Hz~20kHz	—	0.12	—	mV _{rms}
	Cross Talk (CH-A / CH-B)	CT4	—	V _O = -17dBV	—	52	—	dB
	Ripple Rejection Ratio	RR4	—	SW ₆ : a, SW ₁₀ : open f _r = 100Hz, V _r = -32dBV	—	36	—	
Microphone Amplifier + Recording Amplifier	Voltage Gain	G _{V5}	—	SW ₇ : on, V _O = -17dBV	—	58	—	dB
	Maximum Output Voltage	V _{om5}	—	THD = 3%	600	800	—	mV _{rms}
	ALC Total Harmonic Distortion	THD5	—	V _{in} = -32dBV	—	0.8	—	%
	Output Noise Voltage	V _{no5}	—	SW ₆ : a, BPF = 30Hz~20kHz	—	2.1	3.5	mV _{rms}
	ALC Voltage	V _{oALC1}	—	V _{in} = -62dBV	-11.7	-8.5	-6.7	dBV
		V _{oALC2}	—	V _{in} = -32dBV	-11.7	-8.5	-6.7	
	ALC Channel Balance	CB _{ALC}	—	V _{in} = -32dBV	—	0	1.5	dB
	ALC Width	W _{ALC}	—	V _{oALC} ≤ 3dB (Input Voltage) with respect to standard V _{in} = -42dBV	—	48	—	
	Cross Talk (CH-A / CH-B)	CT5	—	V _{in} = -32dBV	—	37	—	
Ripple Rejection Ratio	RR5	—	SW ₆ : a f _r = 100Hz, V _r = -17dBV	—	39	—	dB	
Power Switch	Power On Current	I ₁₂	—	SW ₁ : c, SW ₂ : b, SW ₃ : b V ₆ ≥ 0.6V	5	—	—	μA
	Power Off Voltage	V ₁₂	—	SW ₁ : d, SW ₂ : b, SW ₃ : b V ₆ ≤ 0.2V	0	—	0.3	V

SWITCH CONDITION FOR TEST MODE (Unless otherwise specified.)

MODE	PB AMP. (PB MODE)	BUF AMP. (RADIO MODE)	REC AMP. (RADIO-REC MODE)	MIC AMP. (MIC MODE)	MIC AMP. + REC AMP. (MIC-REC MODE)
OPERATING AMPLIFIER SWITCH	PB	BUF	BUF REC	MIC-ALC BUF, REC	
SW ₂	b	b	a	a	
SW ₃	b	a	a	b	
SW ₄	on	open	open	open	
SW ₅	b	a	a	b	c
SW ₆	a	a	a	b	
SW ₇	open	open	open	on	open

TEST CIRCUIT

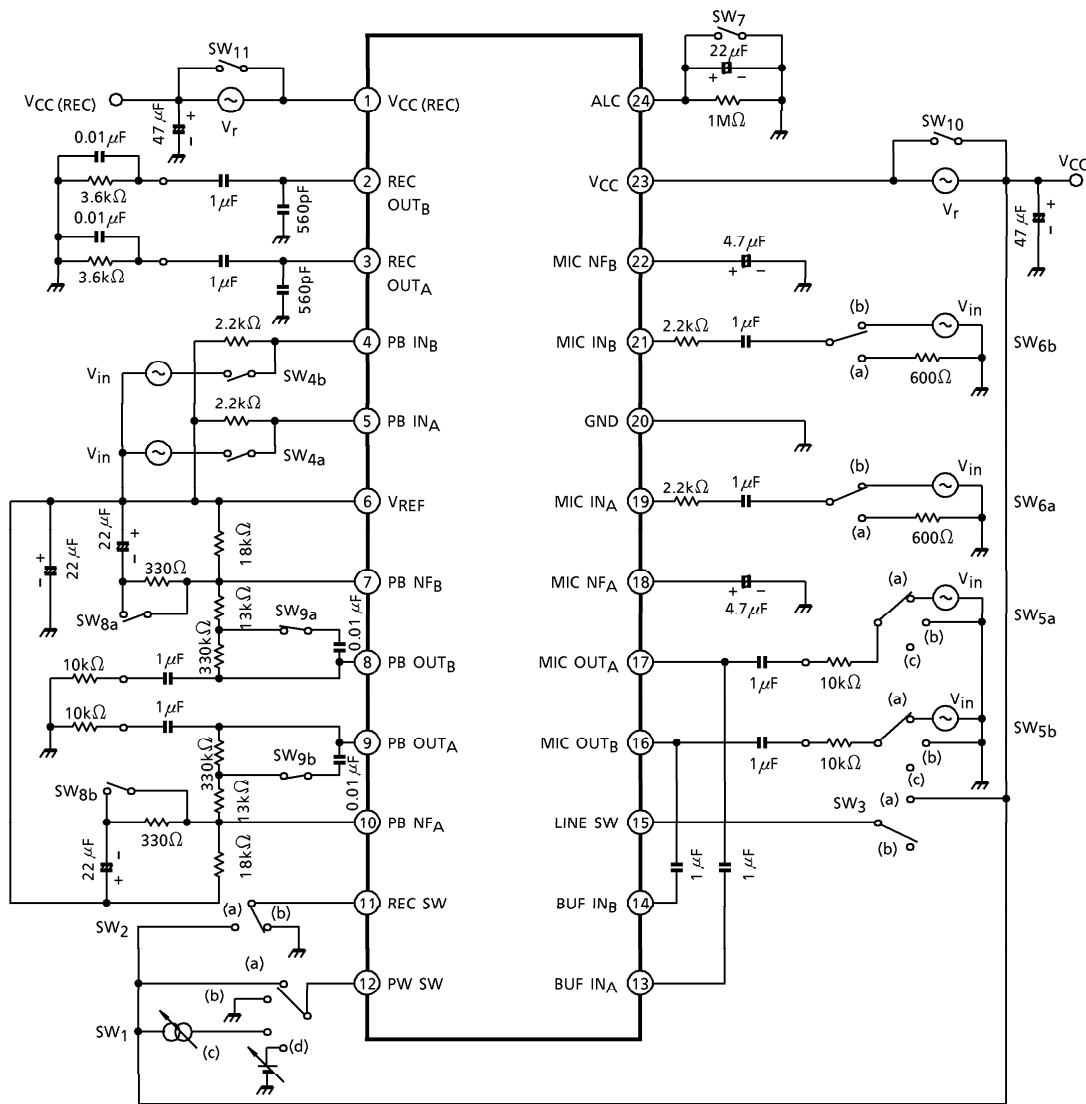

(*) RR5 is measured by circuit below (for V_{CC} line)

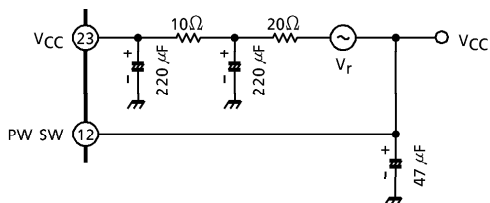

CHARACTERISTIC CURVES

Unless otherwise specified $V_{CC} = 1.2V$, $V_{CC(REC)} = 2.4V$, $f = 1kHz$, $T_a = 25^\circ C$
 $R_L = 10k\Omega$: PB AMP., BUF AMP., MIC AMP.
 (Load of recoding amplifier is shown in test circuit)

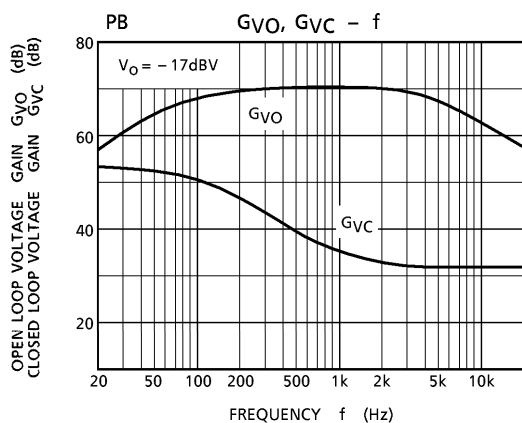
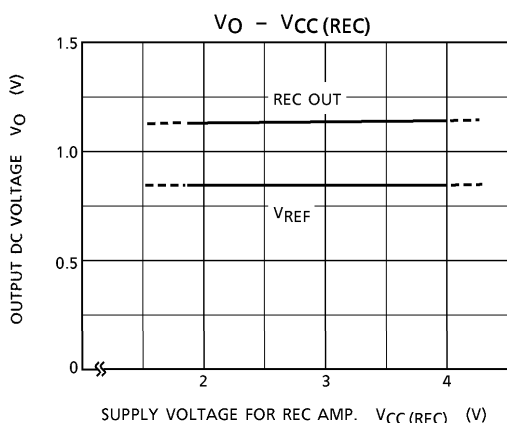
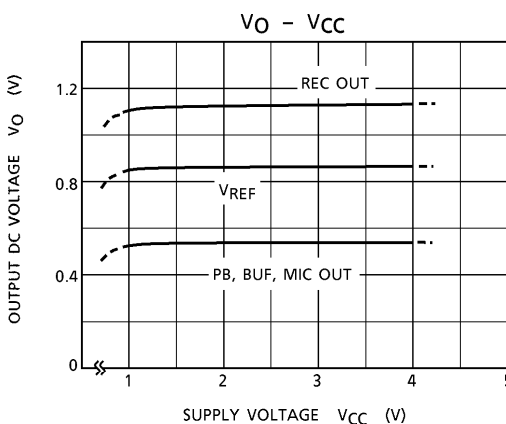
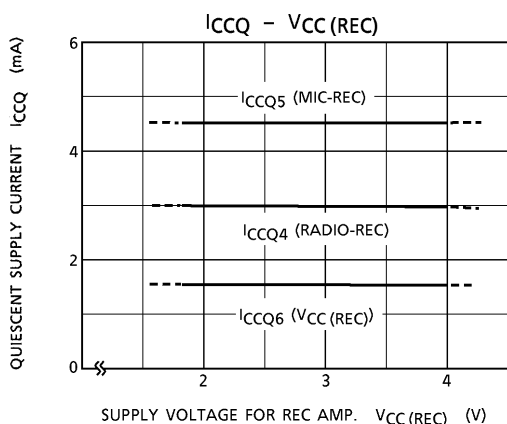
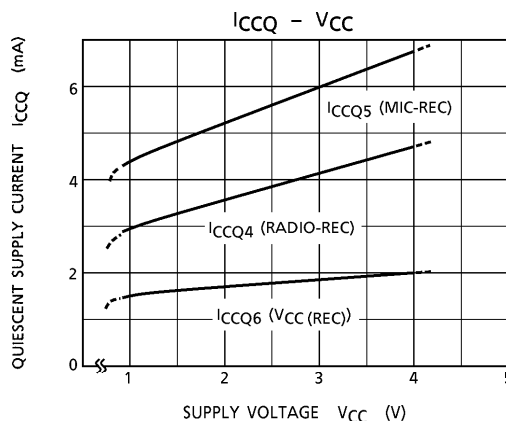
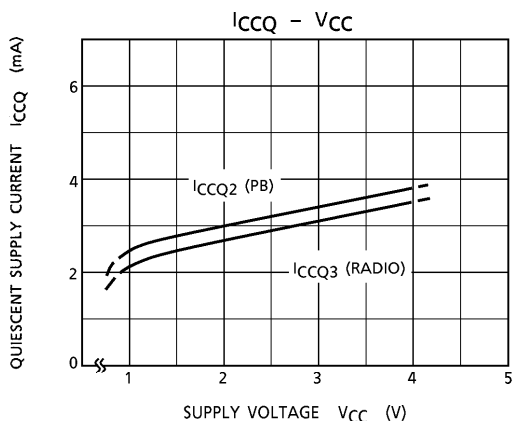

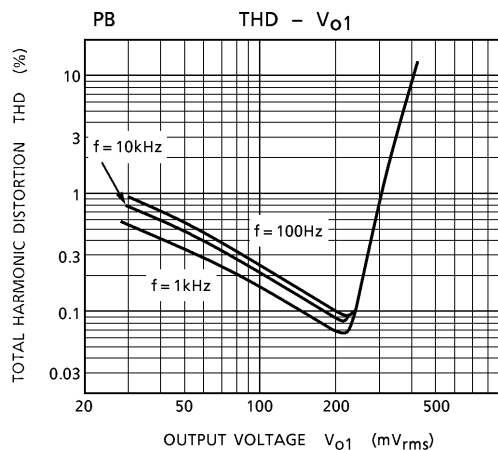
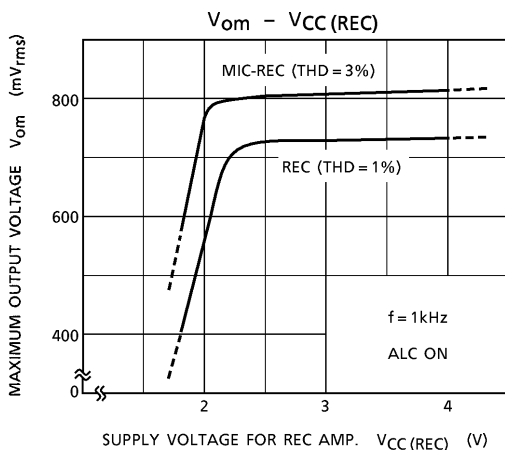
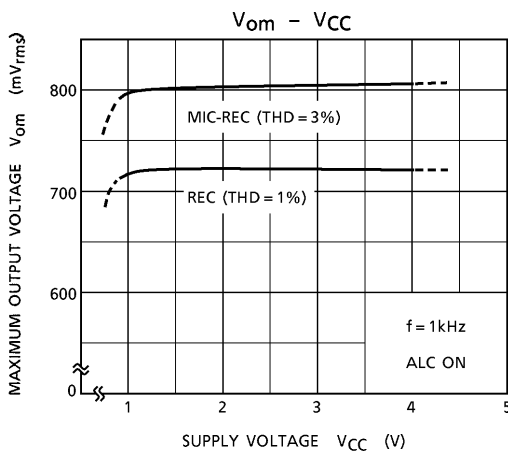
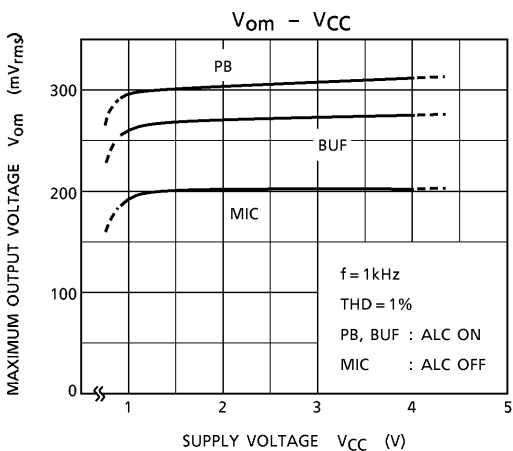
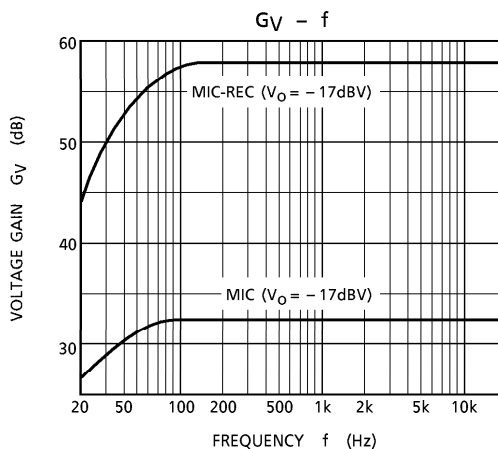
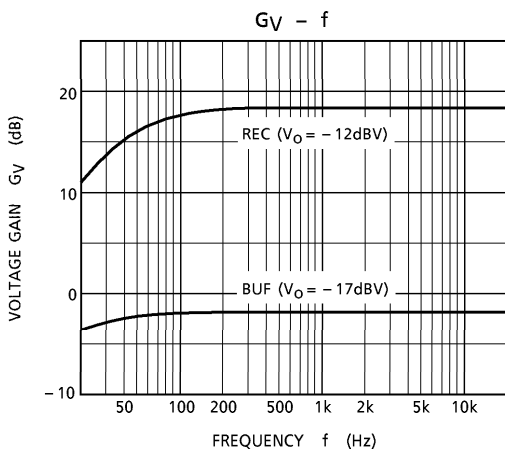

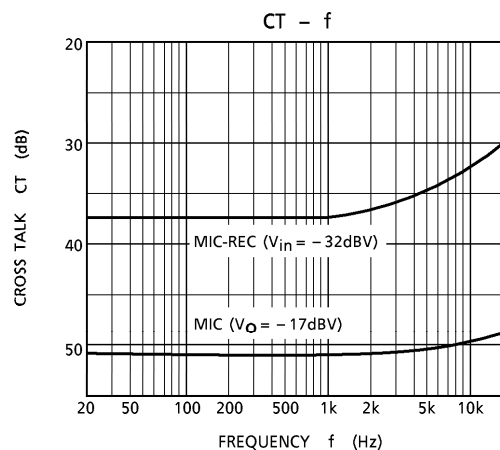
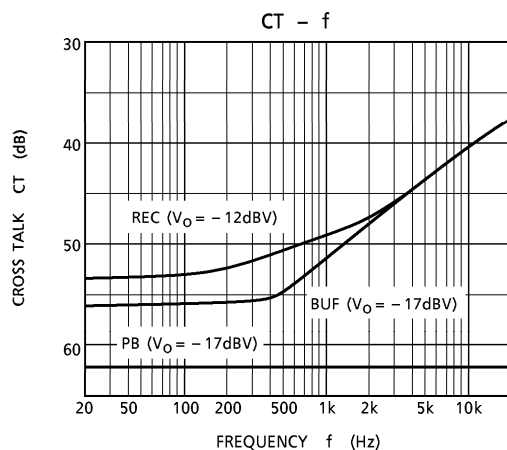
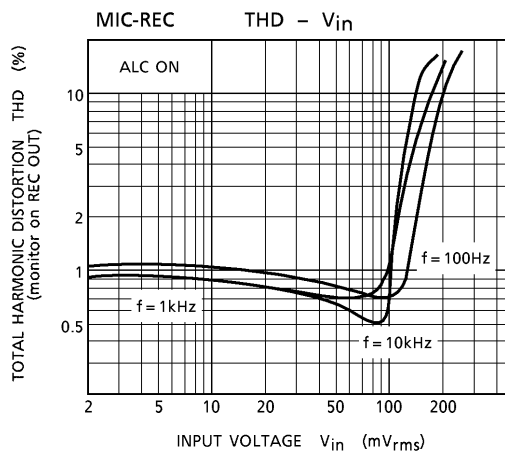
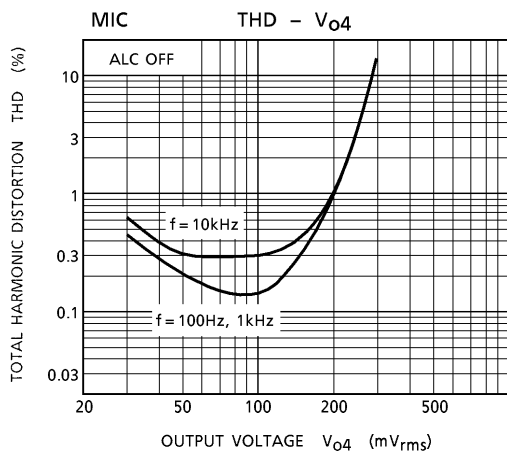
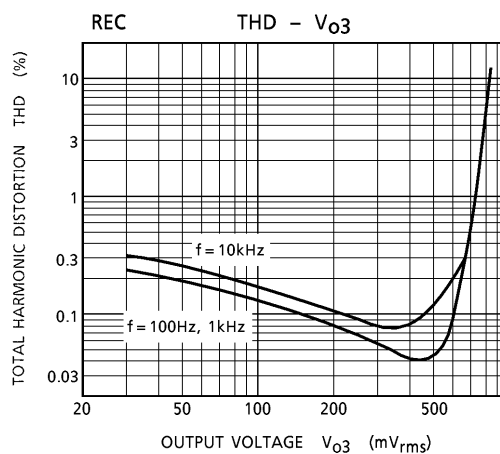
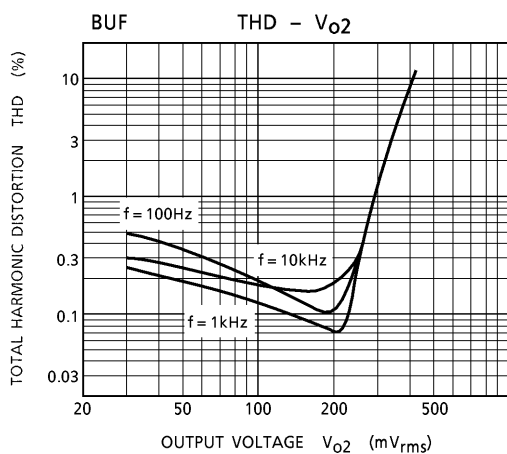

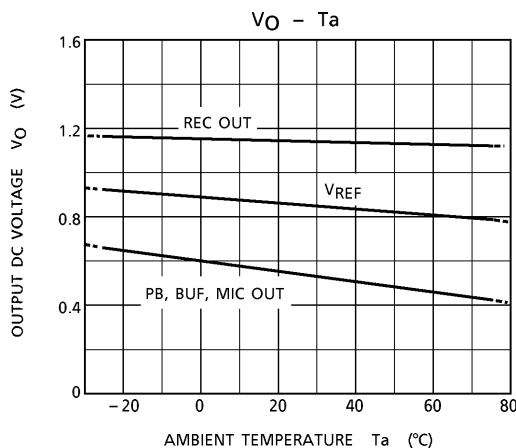
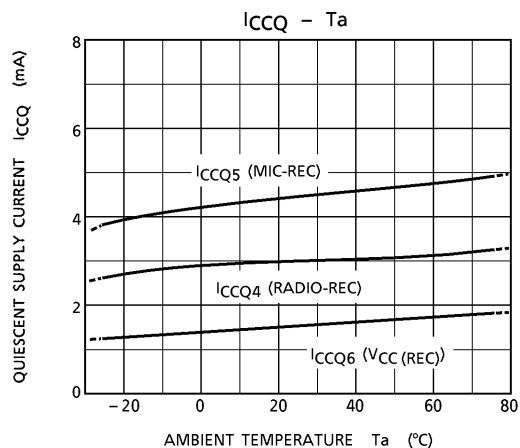
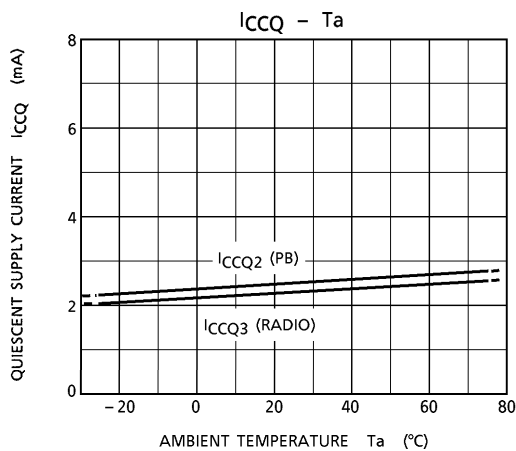
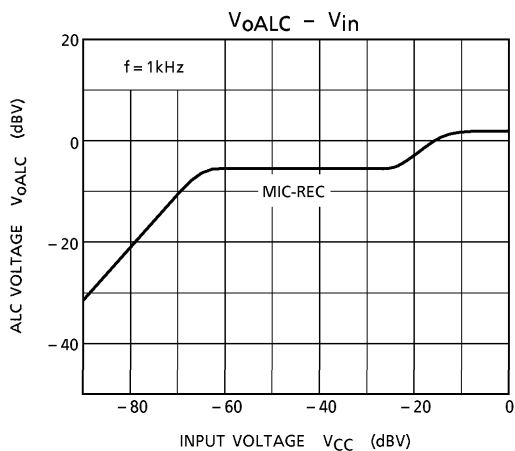
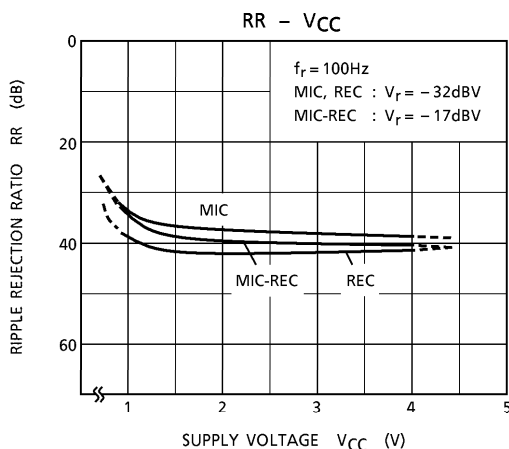
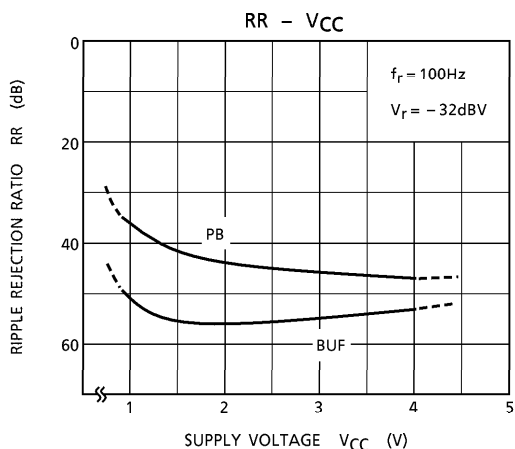

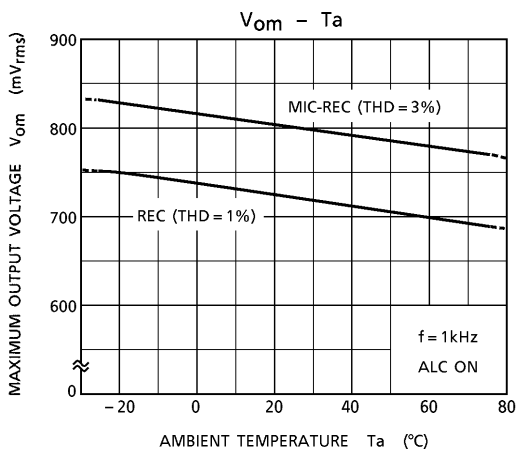
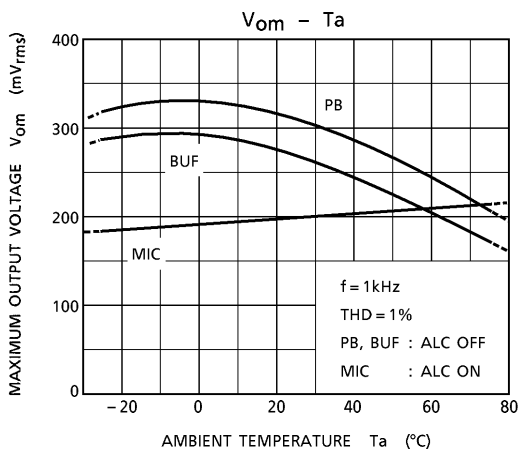
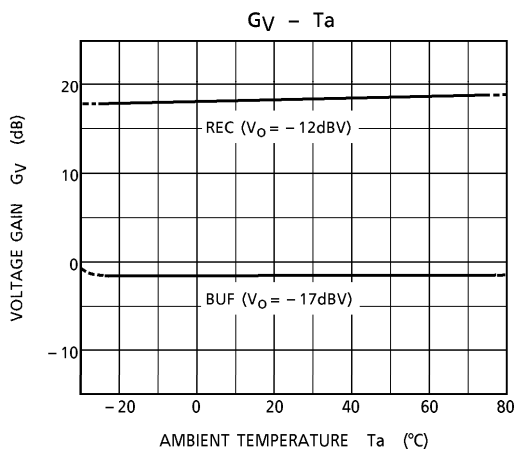
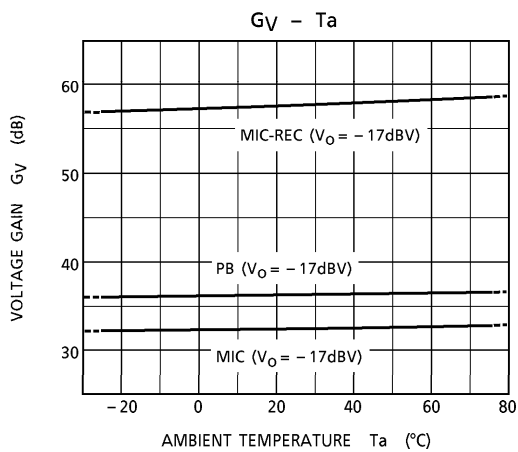

OUTLINE DRAWING
SSOP24-P-300-1.00

Unit : mm

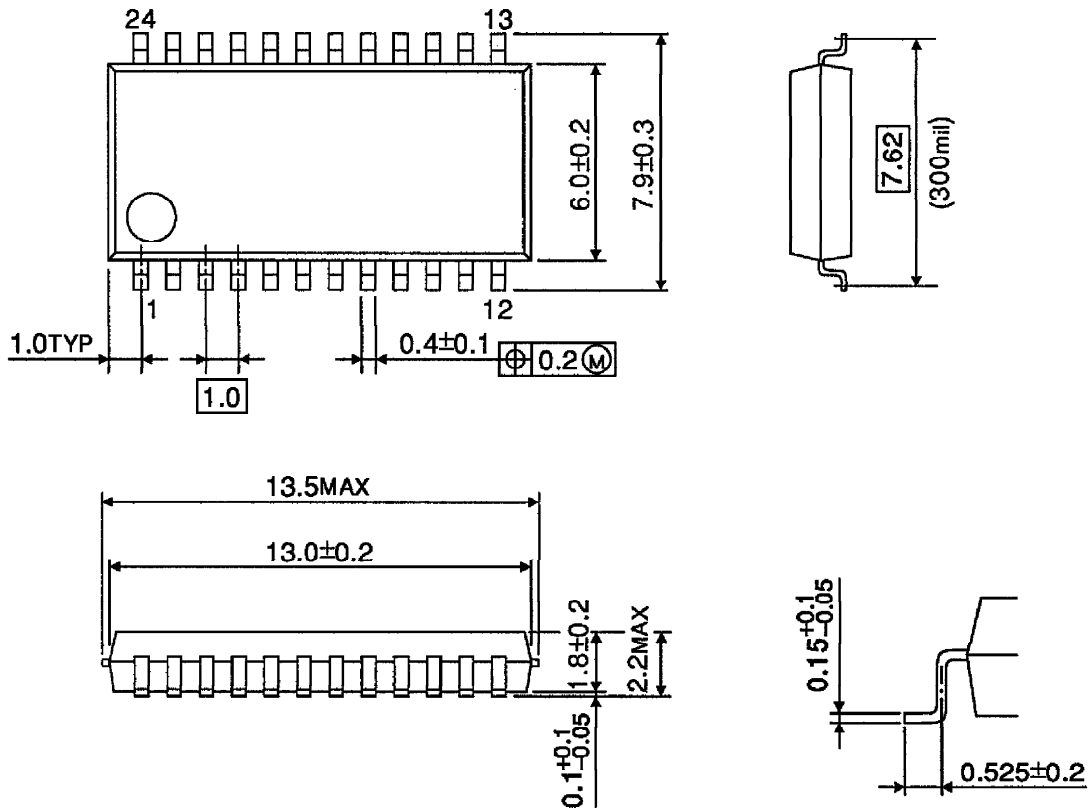

Weight : 0.32g (Typ.)

OUTLINE DRAWING
SSOP24-P-300-0.65A

Unit : mm

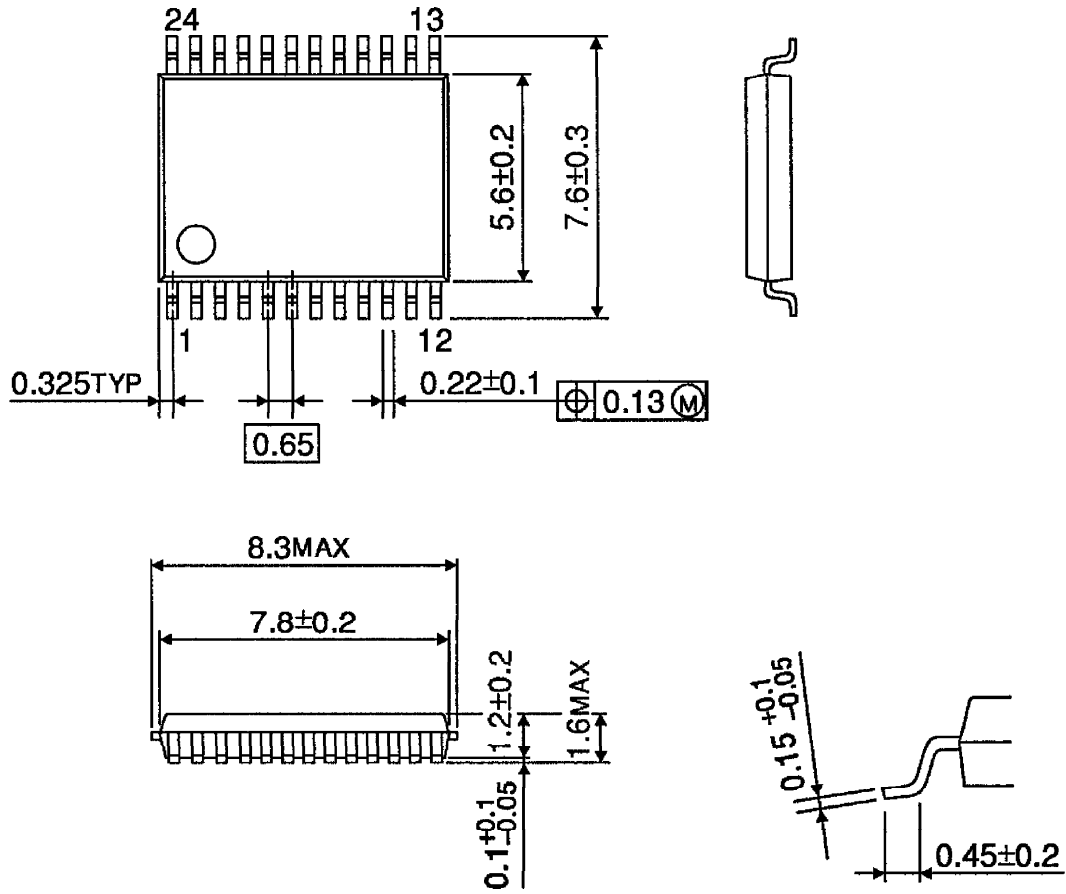

Weight : 0.14g (Typ.)