

**DESCRIPTION/FEATURES**

- LEADLESS PACKAGE FOR SURFACE MOUNT TECHNOLOGY
- IDEAL FOR HIGH DENSITY MOUNTING
- VOLTAGE RANGE—2.4 TO 200 VOLTS
- HERMETICALLY SEALED, DOUBLE-SLUG GLASS CONSTRUCTION
- METALLURGICALLY BONDED CONSTRUCTION AVAILABLE AS DASH ONE.

**MAXIMUM RATINGS**

500 mW DC Power Rating (See Power Derating Curve)  
-65°C to +200°C Operating and Storage Junction Temperature  
Power Derating 3.33 mW/°C above 50°C

**APPLICATION**

This surface mountable zener diode series is similar to the 1N5221 thru 1N5281 registration in the DO-35 equivalent package except that it meets the new JEDEC surface mount outline DO-213AA. It is an ideal selection for applications of high density and low parasitic requirements. Due to its glass hermetic qualities, it may also be considered for high reliability applications when required by a source control drawing (SCD).

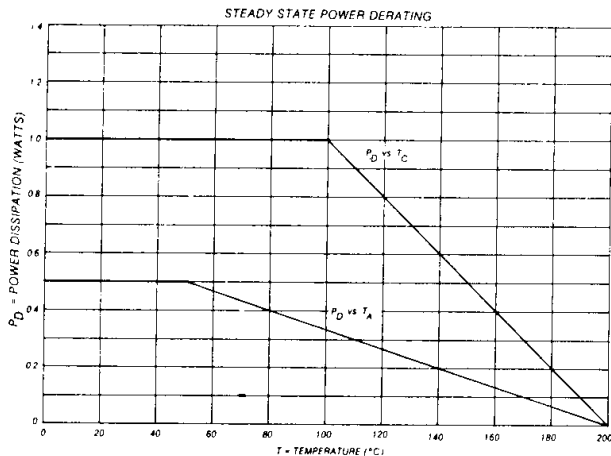

**LEADLESS GLASS  
ZENER DIODES**

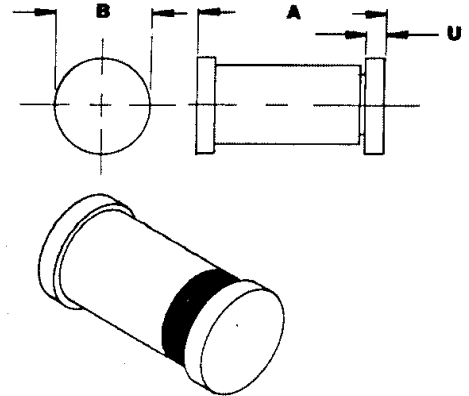

DIM	MILLIMETERS		INCHES	
	MIN	MAX	MIN	MAX
A	3.30	3.70	0.130	0.146
B	1.60	1.70	0.063	0.067
U	.41	.56	0.016	0.022

DO-213AA

**MECHANICAL  
CHARACTERISTICS**

CASE: Hermetically sealed glass with solder contact tabs at each end.

FINISH: All external surfaces are corrosion resistant, readily solderable.

POLARITY: Banded end is cathode.

THERMAL RESISTANCE: 100°C/Watt typical junction to contact (case) tabs.

MOUNTING POSITION: Any.

# MLL5221 thru MLL 5281

## ELECTRICAL CHARACTERISTICS

( $T_A = 25^\circ\text{C}$  unless otherwise noted. Based on dc measurements at thermal equilibrium; case temperature maintained at  $30 \pm 2^\circ\text{C}$ .  $V_F = 1.1\text{V}$  max @  $I_F = 200\text{ mA}$  for all types.)

Type No (Note 1)	Nominal Zener Voltage $V_Z$ @ $I_{ZT}$ Volts (Note 2)	Test Current $I_{ZT}$ mA	Max Zener Impedance A and B Suffix only		Max Reverse Leakage Current				Max Zener Voltage Temperature Coeff $\alpha_{VZ}$ (%/°C) (A and B Suffix only) (Note 3)
			$Z_{ZT}$ @ $I_{ZT}$ Ohms	$Z_{ZK}$ @ $I_{ZK} = 0.25\text{ mA}$ Ohms	A and B Suffix only		Non-Suffix		
					$I_R$ $\mu\text{A}$	@ Volts	$V_R$ Volts	$I_R$ @ $V_R$ Used for Suffix A $\mu\text{A}$	
MLL5221	2.4	20	30	1200	100	0.95	1.0	200	-0.085
MLL5222	2.5	20	30	1250	100	0.95	1.0	200	-0.085
MLL5223	2.7	20	30	1300	75	0.95	1.0	150	-0.080
MLL5224	2.8	20	30	1400	75	0.95	1.0	150	-0.080
MLL5225	3.0	20	29	1600	50	0.95	1.0	100	-0.075
MLL5226	3.3	20	28	1600	25	0.95	1.0	100	-0.070
MLL5227	3.6	20	24	1700	15	0.95	1.0	100	-0.065
MLL5228	3.9	20	23	1900	10	0.95	1.0	75	-0.060
MLL5229	4.1	20	22	2000	5.0	0.95	1.0	50	$\pm 0.055$
MLL5230	4.7	20	19	1900	5.0	1.9	2.0	50	$\pm 0.030$
MLL5231	5.1	20	17	1800	5.0	1.9	2.0	50	$\pm 0.030$
MLL5232	5.6	20	11	1800	5.0	2.9	3.0	50	$\pm 0.038$
MLL5233	6.0	20	7.0	1600	5.0	3.3	3.5	50	$\pm 0.038$
MLL5234	6.2	20	7.0	1000	5.0	3.8	4.0	50	$\pm 0.045$
MLL5235	6.8	20	5.0	750	3.0	4.8	5.0	30	$\pm 0.050$
MLL5236	7.5	20	6.0	500	3.0	5.7	6.0	30	$\pm 0.058$
MLL5237	8.2	20	8.0	500	3.0	6.2	6.5	30	$\pm 0.062$
MLL5238	8.7	20	8.0	600	3.0	6.2	6.5	30	$\pm 0.065$
MLL5239	9.1	20	10	600	3.0	6.7	7.0	30	$\pm 0.068$
MLL5240	10	20	17	600	3.0	7.6	8.0	30	$\pm 0.075$
MLL5241	11	20	22	600	2.0	8.0	8.4	30	$\pm 0.076$
MLL5242	12	20	30	600	1.0	8.7	9.1	10	$\pm 0.077$
MLL5243	13	9.5	13	600	0.5	9.4	9.9	10	$\pm 0.079$
MLL5244	14	9	15	600	0.1	9.5	10	10	$\pm 0.082$
MLL5245	15	8.5	16	600	0.1	10.5	11	10	$\pm 0.082$
MLL5246	16	7.8	17	600	0.1	11.4	12	10	$\pm 0.083$
MLL5247	17	7.4	19	600	0.1	12.4	13	10	$\pm 0.084$
MLL5248	18	7.0	21	600	0.1	13.3	14	10	$\pm 0.085$
MLL5249	19	6.6	23	600	0.1	13.3	14	10	$\pm 0.086$
MLL5250	20	6.2	25	600	0.1	14.3	15	10	$\pm 0.086$
MLL5251	22	5.6	29	600	0.1	16.2	17	10	$\pm 0.087$
MLL5252	24	5.2	33	600	0.1	17.1	18	10	$\pm 0.088$
MLL5253	25	5.0	35	600	0.1	18.1	19	10	$\pm 0.089$
MLL5254	27	4.6	41	600	0.1	20	21	10	$\pm 0.090$
MLL5255	28	4.5	44	600	0.1	20	21	10	$\pm 0.091$
MLL5256	30	4.2	49	600	0.1	22	23	10	$\pm 0.091$
MLL5257	33	3.8	58	700	0.1	24	25	10	$\pm 0.092$
MLL5258	36	3.4	70	700	0.1	26	27	10	$\pm 0.093$
MLL5259	39	3.2	80	800	0.1	29	30	10	$\pm 0.094$
MLL5260	43	3.0	93	900	0.1	31	33	10	$\pm 0.095$
MLL5261	47	2.7	105	1000	0.1	34	36	10	$\pm 0.095$
MLL5262	51	2.5	125	1100	0.1	37	39	10	$\pm 0.096$
MLL5263	56	2.2	150	1300	0.1	41	43	10	$\pm 0.096$
MLL5264	60	2.1	170	1400	0.1	44	46	10	$\pm 0.097$
MLL5265	62	2.0	185	1400	0.1	45	47	10	$\pm 0.097$
MLL5266	68	1.8	230	1600	0.1	49	52	10	$\pm 0.097$
MLL5267	75	1.7	270	1700	0.1	53	56	10	$\pm 0.098$
MLL5268	82	1.5	330	2000	0.1	59	62	10	$\pm 0.098$
MLL5269	87	1.4	370	2200	0.1	65	68	10	$\pm 0.099$
MLL5270	91	1.4	400	2300	0.1	66	69	10	$\pm 0.099$
MLL5271	100	1.3	500	2600	0.1	72	76	10	$\pm 0.110$
MLL5272	110	1.1	750	3000	0.1	80	84	10	$\pm 0.110$
MLL5273	120	1.0	900	4000	0.1	86	91	10	$\pm 0.110$
MLL5274	130	0.95	1100	4500	0.1	94	99	10	$\pm 0.110$
MLL5275	140	0.90	1300	4500	0.1	101	106	10	$\pm 0.110$
MLL5276	150	0.85	1500	5000	0.1	108	114	10	$\pm 0.110$
MLL5277	160	0.80	1700	5500	0.1	116	122	10	$\pm 0.110$
MLL5278	170	0.74	1900	5500	0.1	123	129	10	$\pm 0.110$
MLL5279	180	0.68	2200	6000	0.1	130	137	10	$\pm 0.110$
MLL5280	190	0.66	2400	6500	0.1	137	144	10	$\pm 0.110$
MLL5281	200	0.65	2500	7000	0.1	144	152	10	$\pm 0.110$

CAPACITANCE vs.  $V_Z$  CURVE

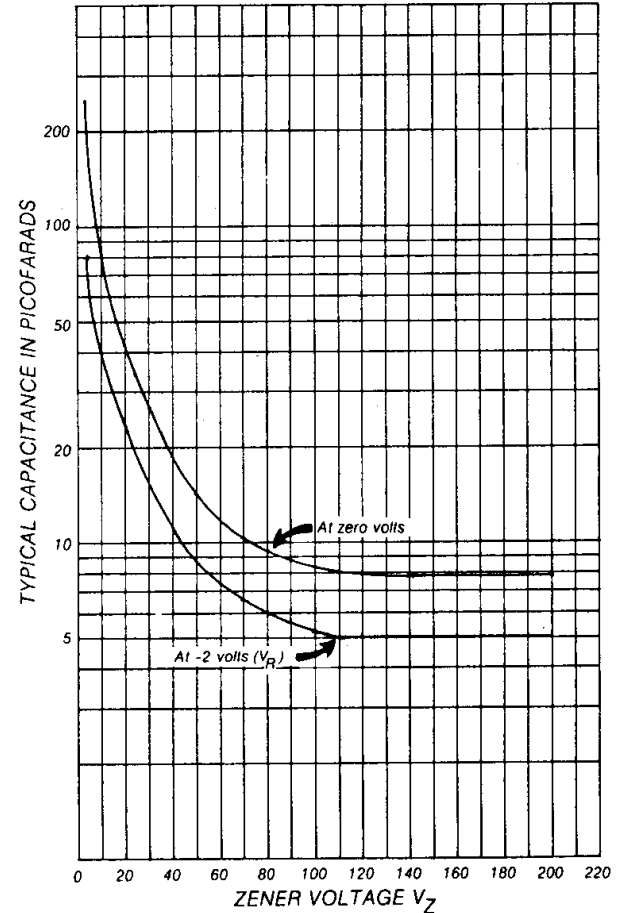

**NOTE 1:** Table as shown lists type numbers, which indicate a tolerance of  $\pm 20\%$  with guaranteed limits on only  $V_Z$ ,  $I_R$ , and  $V_F$ . Devices with guaranteed limits on all six parameters are indicated by suffix "A" for  $\pm 10\%$ , "B" for  $\pm 5\%$ , "C" for  $\pm 2\%$ , and "D" for  $\pm 1\%$  tolerance.

**NOTE 2:** The electrical characteristics are measured after allowing the device to stabilize for 20 seconds.

**NOTE 3:** Temperature coefficient ( $\alpha_{VZ}$ ). Test conditions for temperature coefficient are as follows:

- $I_{ZT} = 7.5\text{ mA}$ ,  $T_1 = 25^\circ\text{C}$ ,  
 $T_2 = 125^\circ\text{C}$  (MLL5221A, B thru MLL5242A, B.)
- $I_{ZT} = \text{Rated } I_{ZT}$ ,  $T_1 = 25^\circ\text{C}$ ,  
 $T_2 = 125^\circ\text{C}$  (MLL5243A, B thru MLL5281A, B.)

Device to be temperature stabilized with current applied prior to reading breakdown voltage at the specified ambient temperature.