

CMOS circuit for Analog Quartz Watches

Description

The H1137 is a low power 32kHz analog watch chip designed to drive a stepping motor. Motor pulse width is programmable from 0.9765 to 14.65 milliseconds in steps of 0.9765 milliseconds. Motor pulse period is programmable from 2 x 1 to 2 x 60 seconds in steps of 1 second. Motor pulse period is also programmable from 2 x 0.25 to 2 x 15.75 seconds in steps of 0.25 seconds. Input and output capacitors are integrated on the chip. Their values are metal mask selectable. The selection of width, period and capacitance are metal options and do not require additional bonds.

Features

- ❑ 32kHz quartz oscillator
- ❑ Operating voltage range – 1.2V to –1.8V
- ❑ High oscillator stability
- ❑ Integrated capacitors, mask selectable
- ❑ Mask options for pad designation, motor period and motor pulse width
- ❑ Shorted motor coil between motor pulses
- ❑ Fast motor test function
- ❑ ESD protected terminals
- ❑ 512Hz output on TEST pad for quartz frequency measurement
- ❑ Fully debounced TEST input and RESET input

Application

- ❑ Analog watches

Functional Diagram

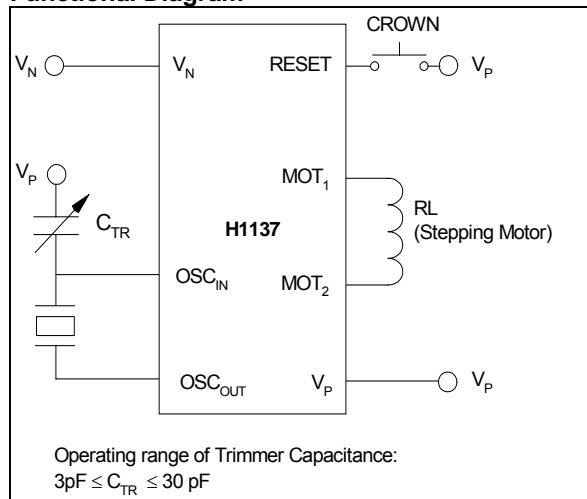

Fig. 1

Pin Assignment

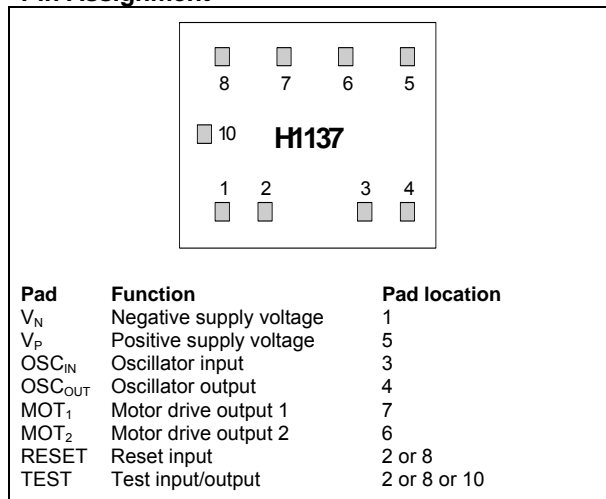

Fig. 2



Absolute Maximum Ratings

Parameter	Symbol	Min.	Typ.	Max.	Units
Supply voltage	V_N	-3.6		+0.2	V
Voltage applied to other terminals		$V_N - 0.3$		$V_P + 0.3$	V
Storage temperature	T_{STOR}	-55		+125	°C

Stresses beyond these listed maximum ratings may cause permanent damage to the device. Exposure to conditions beyond specified operating conditions may affect device reliability or cause malfunction.

Recommended Operating Conditions

Parameter	Symbol	Value	Units
Ambient temperature	T	25	°C
Quartz frequency	f_Q	32768	Hz
Quartz series resistance	R_Q	30	k Ω
Motor coil resistance	R_M	2.0	k Ω
Positive supply	V_P	0	V
Negative supply	V_N	-1.55	V
Supply source resistance	R_I	10	Ω

Handling Procedures

This device contains circuitry to protect the terminals against damage due to high static voltages or electrical fields. However, it is advised that normal precautions be taken to avoid application of any voltage higher than maximum rated voltages to this circuit.

Operating Conditions

Parameter	Symbol	Min.	Typ.	Max.	Units
Operating temperature	T_{OPR}	-10	30	+60	°C
Quartz series resistance				50	k Ω
Trimmer capacitance	C_{TR}	3		30	pF

Electrical and Switching Characteristics

at recommended operating conditions unless otherwise specified

Parameter	Symbol	Test Conditions	Min.	Typ.	Max.	Units
Supply voltage range	V_N		-1.8	-1.55	-1.2	V
Mean dynamic current	I_{DYN}	Without motor and quartz, 32kHz inverted square wave forced at OSC_{IN} and OSC_{OUT} , TEST open		90	150	nA
Mean current consumption	I_N	With quartz, without motor, TEST open, $C_{TR} = 12$ pF		200	350	nA
Oscillator						
Transconductance	gm	$V_N = 1.2V$, $V_{PP} = 300mV$	2.5			μmho
Starting voltage	V_{ST}	Within 10 seconds		0.75		V
Starting time	T_{ST}	Recommended operating conditions			2	s
Stability $df / f \cdot dV_N$		Between -1.4V and -1.6V		1.5		ppm/V
Motors Drivers						
Voltage across motor	V_{MOT}	$V_N = -1.55V$, $R_M = 2k \Omega$	1.35	1.40		V
Voltage across motor	V_{MOT}	$V_N = -1.25V$, $R_M = 2k \Omega$	1.0	1.10		V
Voltage across motor	V_{MOT}	$R_I = 300 \Omega$, T_{OPR}	1.0	1.20		V
Short circuit impedance	R_{CC}	Between motor pulses		150	300	Ω
Test Input / Output						
Amplitude	V_{TST}	$Z_I = 30pF // 1M \Omega$	1.35			V_{PP}
Mean current	I_{TST}	Pad connected to V_P		70	250	nA
Reset Input						
Debounce delay	T_S		7.81		23.43	ms
Input current after debounce delay*	I_S	Pad connected to V_P		7	50	nA

* Is the average input current, modulated by a frequency of 64 Hz

Timing Waveforms

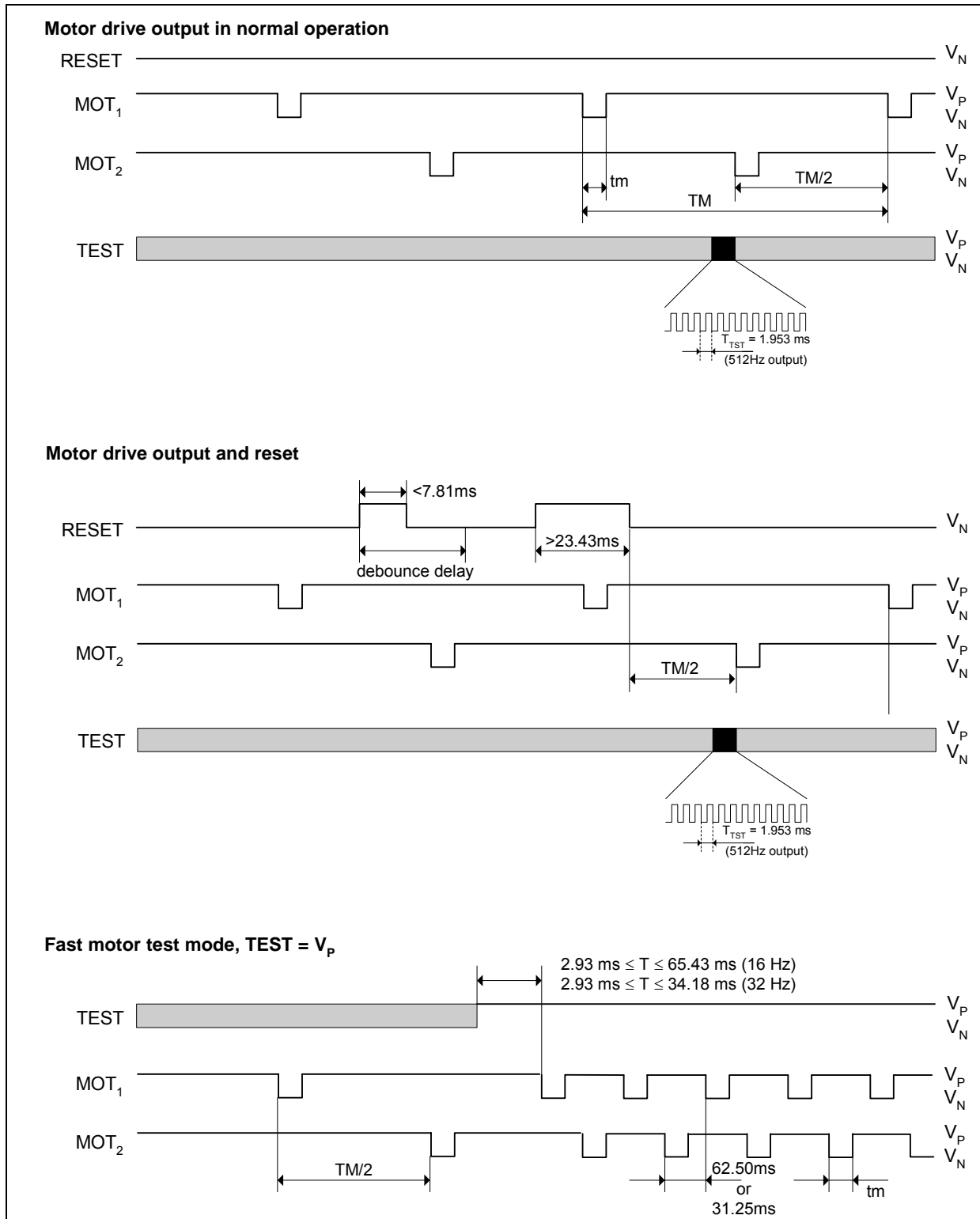

Fig. 3

Block Diagram

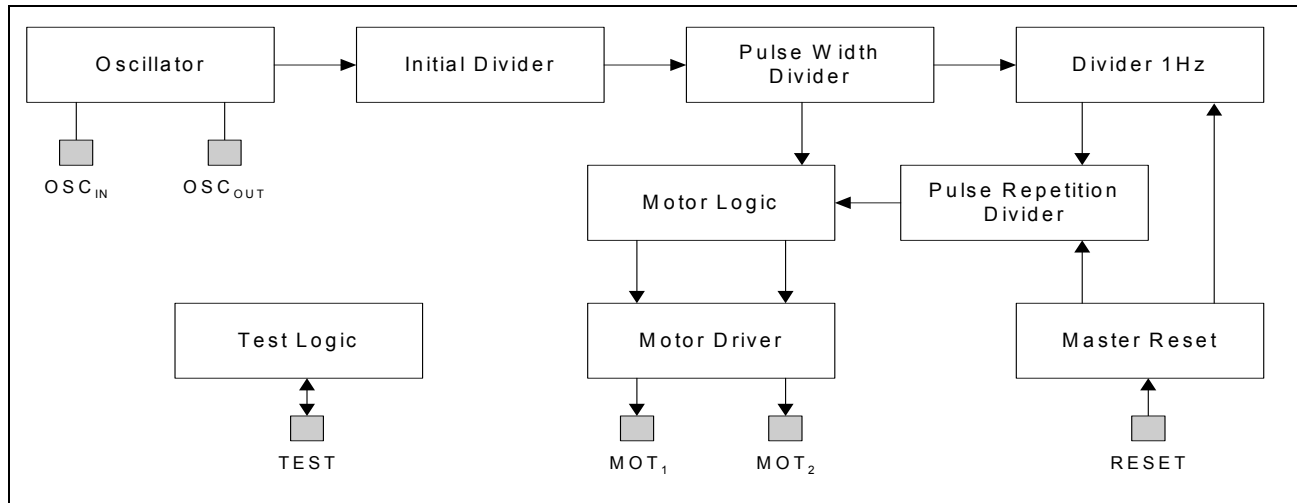

Fig. 4

Pin Assignments

Name	Function
V _N	Negative supply voltage
V _P	Positive supply voltage
OSC _{IN}	Oscillator input
OSC _{OUT}	Oscillator output
MOT ₁	Motor drive output 1
MOT ₂	Motor drive output 2
RESET	Reset input
TEST	Test input / output

Functional Description

Oscillator

The 32768Hz clock frequency is generated by a crystal oscillator. Input and output capacitors are integrated in the chip. Their values are metal mask selectable.

Motor drive output

The H1137 contains two push-pull output buffers for driving bipolar stepping motors (see Fig. 3). Between two pulses, the two p-channel devices are active for motor damping.

Reset

Pulling the RESET input to V_P resets the frequency dividers and disables the motor pulses. Motor pulses in progress when the RESET function is applied, will be completed. After releasing the RESET pad from V_P, the next motor pulse appears with a delay of one half motor cycle on the drive output MOT₁ if the last motor pulse appeared on MOT₂ or vice-versa (see Fig. 3). Due to the debounce circuitry on the RESET input, V_P must be applied for at least 23.4 ms to be accepted as RESET.

Test mode

The TEST pad fulfils two functions:

- For normal operation, the TEST pad is left open. The circuit outputs a square wave signal of 512Hz which can be used for tuning the oscillator.
- If the TEST pad is connected to V_P, the period for the motor pulses changes to either 2 x 31.25 ms or 2 x 62.5 ms (mask options), while the motor pulse width remains unchanged (fast motor test).

Test

Test Pad	Function	Description
Connected to V _P	Fast motor test	Increase the frequency for the motor pulses to 16Hz (32Hz)
Open	Normal operation	Output of square wave signal (512Hz)

Test configuration

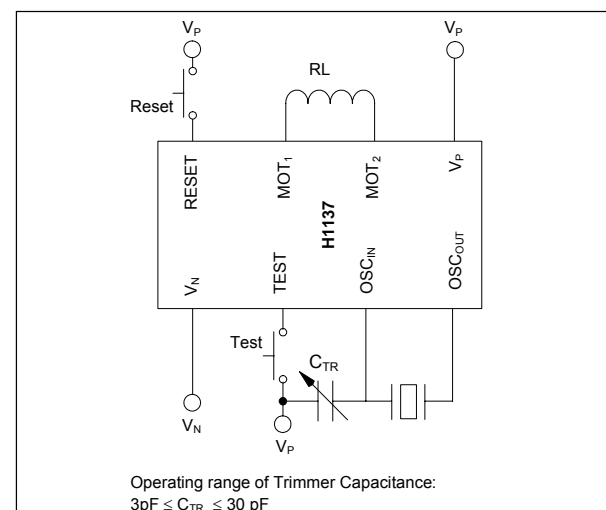

Fig. 5



H1137

Metal Mask Option Possibilities Motor pulse and capacitance

Sym- bol	Description	Range min.	Range max.	Range resolut.
TM	Motor pulse period	2x1.00s	2x60.00s	1.00s
TM	Fast motor TEST	2x31.25ms	2x62.50ms	
tm	Motor pulse width	0.9765ms	14.65ms	0.9765ms
C _{IN}	Oscillator input capacity	2pF	C _{IN} + C _{OUT}	1pF
C _{OUT}	Oscillator output capac.	2.7pF	≈35pF	1pF

Pad options

Sym- bol	Description	Pad Layout 1	Pad Layout 2	Pad Layout 3
TEST	Pad TEST	Pad 10	Pad 2	Pad 8
RESET	Pad RESET	Pad 8 Pad 2	Pad 8 Pad 10	Pad 2 Pad 10
		not used	not used	not used

Possible versions Option list (supply voltage -1.55V)

Version	Options															Com- patible EURO- SIL E1208
	Motor Output			Integrated capacitor		Designation pad										
	Period s	Pulse Width ms	Fast Mode ms	OSC _{IN} pF	OSC _{OUT} pF	Pad 1	Pad 2	Pad 3	Pad 4	Pad 5	Pad 6	Pad 7	Pad 8	Pad 10		
H1137V01	2x12	6.8	2x62.5	2	18	V _N	-	OSC _{IN}	OSC _{OUT}	V _P	MOT ₂	MOT ₁	RESET	TEST	A	
H1137V02	2x1	3.9	2x62.5	2	14	V _N	TEST	OSC _{IN}	OSC _{OUT}	V _P	MOT ₂	MOT ₁	RESET	-	B	
H1137V03	2x10	7.8	2x62.5	2	22	V _N	RESET	OSC _{IN}	OSC _{OUT}	V _P	MOT ₂	MOT ₁	TEST	-	C	
H1137V04	2x12	5.9	2x62.5	2	14	V _N	TEST	OSC _{IN}	OSC _{OUT}	V _P	MOT ₂	MOT ₁	RESET	-	D	
H1137V05	2x1	6.8	2x62.5	2	14	V _N	TEST	OSC _{IN}	OSC _{OUT}	V _P	MOT ₂	MOT ₁	RESET	-	E	
H1137V07	2x10	5.9	2x62.5	2	16	V _N	RESET	OSC _{IN}	OSC _{OUT}	V _P	MOT ₂	MOT ₁	TEST	-	G	
H1137V08	2x12	6.8	2x62.5	2	14	V _N	TEST	OSC _{IN}	OSC _{OUT}	V _P	MOT ₂	MOT ₁	RESET	-	H	
H1137V09	2x1	7.8	2x62.5	2	20	V _N	TEST	OSC _{IN}	OSC _{OUT}	V _P	MOT ₂	MOT ₁	RESET	-	IS	
H1137V10	2x1	3.9	2x62.5	2	14	V _N	-	OSC _{IN}	OSC _{OUT}	V _P	MOT ₂	MOT ₁	RESET	TEST	K	
H1137V11	2x12	5.9	2x62.5	2	14	V _N	-	OSC _{IN}	OSC _{OUT}	V _P	MOT ₂	MOT ₁	RESET	TEST	L	
H1137V12	2x1	6.8	2x62.5	2	14	V _N	-	OSC _{IN}	OSC _{OUT}	V _P	MOT ₂	MOT ₁	RESET	TEST	M	
H1137V13	2x12	6.8	2x62.5	2	14	V _N	-	OSC _{IN}	OSC _{OUT}	V _P	MOT ₂	MOT ₁	RESET	TEST	N	
H1137V14	2x1	4.9	2x62.5	2	16	V _N	TEST	OSC _{IN}	OSC _{OUT}	V _P	MOT ₂	MOT ₁	RESET	-	O	
H1137V15	2x1	6.8	2x62.5	2	20	V _N	TEST	OSC _{IN}	OSC _{OUT}	V _P	MOT ₂	MOT ₁	RESET	-	P	
H1137V16	2x1	5.9	2x62.5	2	14	V _N	TEST	OSC _{IN}	OSC _{OUT}	V _P	MOT ₂	MOT ₁	RESET	-	S	
H1137V17	2x5	5.9	2x62.5	2	14	V _N	TEST	OSC _{IN}	OSC _{OUT}	V _P	MOT ₂	MOT ₁	RESET	-	T	
H1137V19	2x20	7.8	2x62.5	2	14	V _N	TEST	OSC _{IN}	OSC _{OUT}	V _P	MOT ₂	MOT ₁	RESET	-	V	
H1137V20	2x20	5.9	2x62.5	2	14	V _N	TEST	OSC _{IN}	OSC _{OUT}	V _P	MOT ₂	MOT ₁	RESET	-	WA	
H1137V21	2x1	4.9	2x62.5	2	14	V _N	TEST	OSC _{IN}	OSC _{OUT}	V _P	MOT ₂	MOT ₁	RESET	-	WB	
H1137V22	2x1	3.9	2x62.5	2	20	V _N	TEST	OSC _{IN}	OSC _{OUT}	V _P	MOT ₂	MOT ₁	RESET	-	WD	
H1137V23	2x1	5.9	2x62.5	2	20	V _N	TEST	OSC _{IN}	OSC _{OUT}	V _P	MOT ₂	MOT ₁	RESET	-	WE	
H1137V24	2x10	6.8	2x62.5	2	14	V _N	TEST	OSC _{IN}	OSC _{OUT}	V _P	MOT ₂	MOT ₁	RESET	-	WF	
H1137V25	2x5	7.8	2x62.5	2	20	V _N	TEST	OSC _{IN}	OSC _{OUT}	V _P	MOT ₂	MOT ₁	RESET	-	WG	
H1137V26	2x20	6.8	2x31.25	2	14	V _N	TEST	OSC _{IN}	OSC _{OUT}	V _P	MOT ₂	MOT ₁	RESET	-	WH	
H1137V27	2x0.5	4.9	2x62.5	2	14	V _N	TEST	OSC _{IN}	OSC _{OUT}	V _P	MOT ₂	MOT ₁	RESET	-		
H1137V28	2x40	5.9	2x62.5	2	14	V _N	TEST	OSC _{IN}	OSC _{OUT}	V _P	MOT ₂	MOT ₁	RESET	-		
H1137V51	2x5	4.9	2x31.25	2	23	V _N	TEST	OSC _{IN}	OSC _{OUT}	V _P	MOT ₂	MOT ₁	RESET	-		
H1137V52	2x5	7.8	2x31.25	2	23	V _N	TEST	OSC _{IN}	OSC _{OUT}	V _P	MOT ₂	MOT ₁	RESET	-		
H1137V53	2x1	3.9	2x31.25	2	23	V _N	TEST	OSC _{IN}	OSC _{OUT}	V _P	MOT ₂	MOT ₁	RESET	-		
H1137V54	2x20	4.9	2x31.25	2	23	V _N	TEST	OSC _{IN}	OSC _{OUT}	V _P	MOT ₂	MOT ₁	RESET	-		
H1137V58	2x10	4.9	2x31.25	2	25	V _N	RESET	OSC _{IN}	OSC _{OUT}	V _P	MOT ₂	MOT ₁	TEST	-		

Ordering Information

For other versions, please contact EM Microelectronic-Marin S.A.
Please make sure to give the complete part number when ordering.

H1137 WW 11 - %%%

Customer Version:
customer-specific number
given by EM Microelectronic

Thickness:
11 = 11 mils (280um)
27 = 27 mils (686um)
(for other thickness, contact EM)

Die form:
WW = Wafer
WS = Sawn Wafer/Frame
WP = Waffle Pack

Chip Information

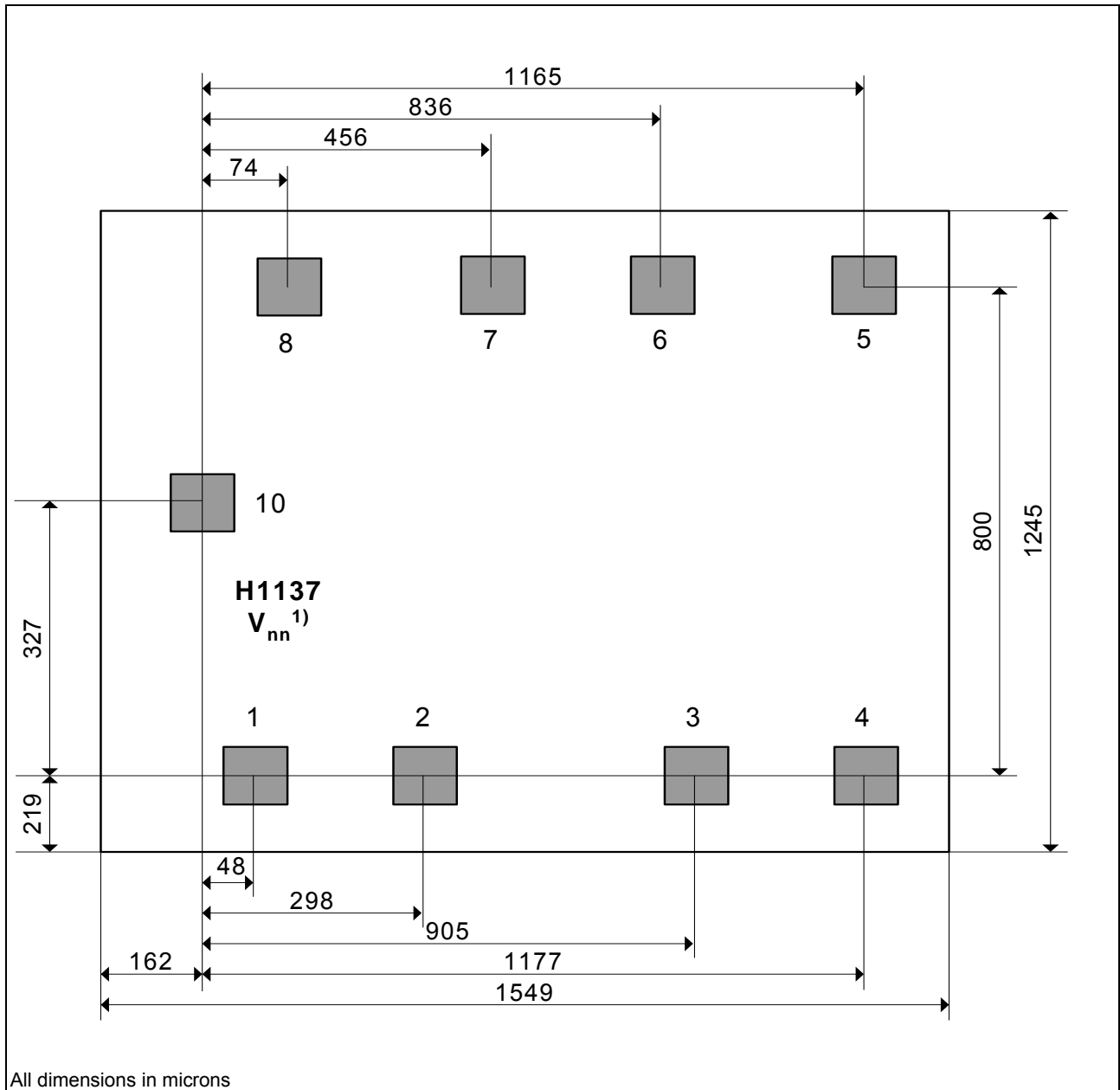

¹⁾ nn stands for the version

Fig. 6

EM Microelectronic-Marin SA cannot assume responsibility for use of any circuitry described other than circuitry entirely embodied in an EM Microelectronic-Marin SA product. EM Microelectronic-Marin SA reserves the right to change the circuitry and specifications without notice at any time. You are strongly urged to ensure that the information given has not been superseded by a more up-to-date version.

© EM Microelectronic-Marin SA, 11/04, Rev. A