

CMOS circuit for Analog Quartz Watches

Description

The H1137 is a low power 32kHz analog watch chip designed to drive a stepping motor. Motor pulse width is programmable from 0.9765 to 14.65 milliseconds in steps of 0.9765 milliseconds. Motor pulse period is programmable from 2 x 1 to 2 x 60 seconds in steps of 1 second. Motor pulse period is also programmable from 2 x 0.25 to 2 x 15.75 seconds in steps of 0.25 seconds. Input and output capacitors are integrated on the chip. Their values are metal mask selectable. The selection of width, period and capacitance are metal options and do not require additional bonds.

Features

- ❑ 32kHz quartz oscillator
- ❑ Operating voltage range – 1.2V to –1.8V
- ❑ High oscillator stability
- ❑ Integrated capacitors, mask selectable
- ❑ Mask options for pad designation, motor period and motor pulse width
- ❑ Shorted motor coil between motor pulses
- ❑ Fast motor test function
- ❑ ESD protected terminals
- ❑ 512Hz output on TEST pad for quartz frequency measurement
- ❑ Fully debounced TEST input and RESET input

Application

- ❑ Analog watches

Functional Diagram

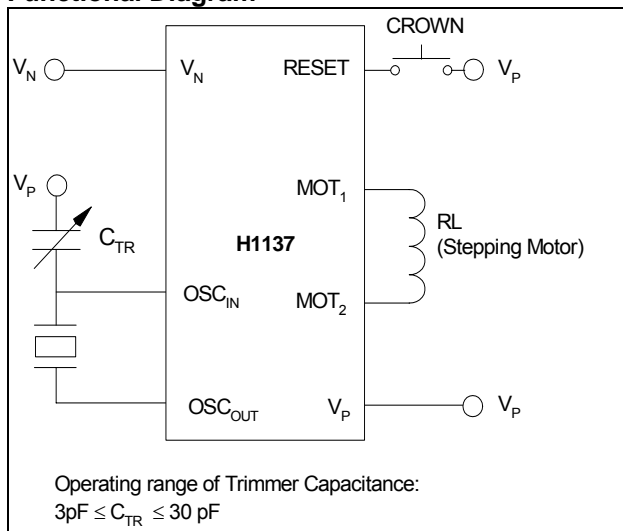

Fig. 1

Pin Assignment

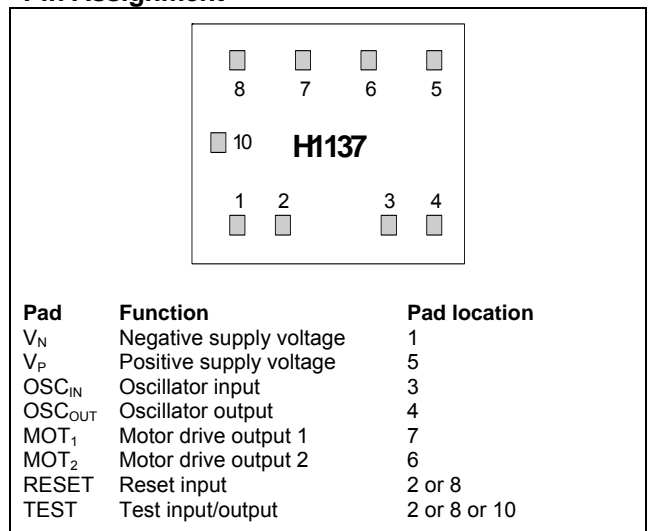
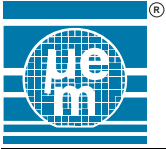

Fig. 2



Absolute Maximum Ratings

| Parameter | Symbol | Min. | Typ. | Max. | Units |
|------------------------------------|------------|-------------|------|-------------|-------|
| Supply voltage | V_N | -3.6 | | +0.2 | V |
| Voltage applied to other terminals | | $V_N - 0.3$ | | $V_P + 0.3$ | V |
| Storage temperature | T_{STOR} | -55 | | +125 | °C |

Stresses beyond these listed maximum ratings may cause permanent damage to the device. Exposure to conditions beyond specified operating conditions may affect device reliability or cause malfunction.

Recommended Operating Conditions

| Parameter | Symbol | Value | Units |
|--------------------------|--------|-------|------------|
| Ambient temperature | T | 25 | °C |
| Quartz frequency | f_Q | 32768 | Hz |
| Quartz series resistance | R_Q | 30 | k Ω |
| Motor coil resistance | R_M | 2.0 | k Ω |
| Positive supply | V_P | 0 | V |
| Negative supply | V_N | -1.55 | V |
| Supply source resistance | R_I | 10 | Ω |

Handling Procedures

This device contains circuitry to protect the terminals against damage due to high static voltages or electrical fields. However, it is advised that normal precautions be taken to avoid application of any voltage higher than maximum rated voltages to this circuit.

Operating Conditions

| Parameter | Symbol | Min. | Typ. | Max. | Units |
|--------------------------|-----------|------|------|------|------------|
| Operating temperature | T_{OPR} | -10 | | +60 | °C |
| Quartz series resistance | | | 30 | 50 | k Ω |
| Trimmer capacitance | C_{TR} | 3 | | 30 | pF |

Electrical and Switching Characteristics

at recommended operating conditions unless otherwise specified

| Parameter | Symbol | Test Conditions | Min. | Typ. | Max. | Units |
|-------------------------------------|-----------|---|------|-------|-------|-----------|
| Supply voltage range | V_N | | -1.8 | -1.55 | -1.2 | V |
| Mean dynamic current | I_{DYN} | Without motor and quartz, 32kHz inverted square wave forced at OSC_{IN} and OSC_{OUT} , TEST open | | 90 | 150 | nA |
| Mean current consumption | I_N | With quartz, without motor, TEST open, $C_{TR} = 12$ pF | | 200 | 350 | nA |
| Oscillator | | | | | | |
| Transconductance | gm | $V_N = 1.2V$, $V_{PP} = 300mV$ | 2.5 | | | μmho |
| Starting voltage | V_{ST} | Within 10 seconds | | 0.75 | | V |
| Starting time | T_{ST} | Recommended operating conditions | | | 2 | s |
| Stability $df / f * dV_N$ | | Between -1.4V and -1.6V | | 1.5 | | ppm/V |
| Motors Drivers | | | | | | |
| Voltage across motor | V_{MOT} | $V_N = -1.55V$, $R_M = 2k \Omega$ | 1.35 | 1.40 | | V |
| Voltage across motor | V_{MOT} | $V_N = -1.25V$, $R_M = 2k \Omega$ | 1.0 | 1.10 | | V |
| Voltage across motor | V_{MOT} | $R_I = 300 \Omega$, T_{OPR} | 1.0 | 1.20 | | V |
| Short circuit impedance | R_{CC} | Between motor pulses | | 150 | 300 | Ω |
| Test Input / Output | | | | | | |
| Amplitude | V_{TST} | $Z_I = 30pF // 1M \Omega$ | 1.35 | | | V_{PP} |
| Mean current | I_{TST} | Pad connected to V_P | | 70 | 250 | nA |
| Reset Input | | | | | | |
| Debounce delay | T_S | | 7.81 | | 23.43 | ms |
| Input current after debounce delay* | I_S | Pad connected to V_P | | 7 | 50 | nA |

* Is the average input current, modulated by a frequency of 64 Hz



H1137

Block Diagram

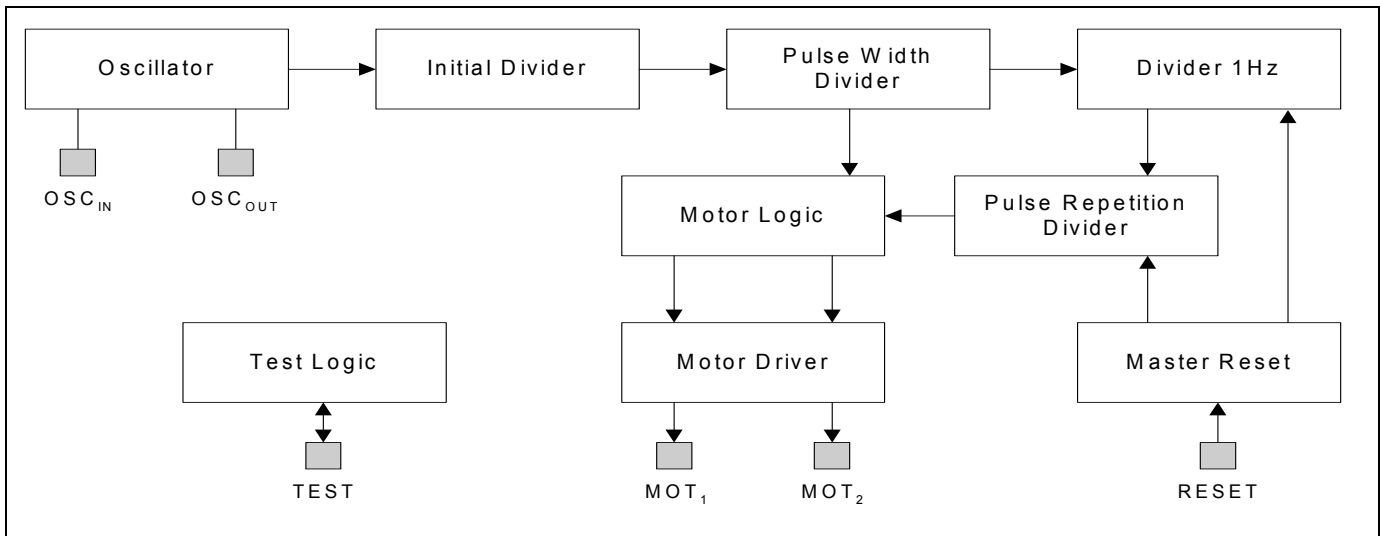

Fig. 4

Pin Assignments

| Name | Function |
|--------------------|-------------------------|
| V _N | Negative supply voltage |
| V _P | Positive supply voltage |
| OSC _{IN} | Oscillator input |
| OSC _{OUT} | Oscillator output |
| MOT ₁ | Motor drive output 1 |
| MOT ₂ | Motor drive output 2 |
| RESET | Reset input |
| TEST | Test input / output |

Functional Description

Oscillator

The 32'768Hz clock frequency is generated by a crystal oscillator. Input and output capacitors are integrated in the chip. Their values are metal mask selectable.

Motor drive output

The H1137 contains two push-pull output buffers for driving bipolar stepping motors (see Fig. 3). Between two pulses, the two p-channel devices are active for motor damping.

Reset

Pulling the RESET input to V_P resets the frequency dividers and disables the motor pulses. Motor pulses in progress when the RESET function is applied, will be completed. After releasing the RESET pad from V_P, the next motor pulse appears with a delay of one half motor cycle on the drive output MOT₁ if the last motor pulse appeared on MOT₂ or vice-versa (see Fig. 3). Due to the debounce circuitry on the RESET input, V_P must be applied for at least 23.4 ms to be accepted as RESET.

Test mode

The TEST pad fulfils two functions:

- For normal operation, the TEST pad is left open. The circuit outputs a square wave signal of 512Hz which can be used for tuning the oscillator.
- If the TEST pad is connected to V_P, the period for the motor pulses changes to either 2 x 31.25 ms or 2 x 62.5 ms (mask options), while the motor pulse width remains unchanged (fast motor test).

Test

| Test Pad | Function | Description |
|-----------------------------|------------------|--|
| Connected to V _P | Fast motor test | Increase the frequency for the motor pulses to 16Hz (32Hz) |
| Open | Normal operation | Output of square wave signal (512Hz) |

Test configuration

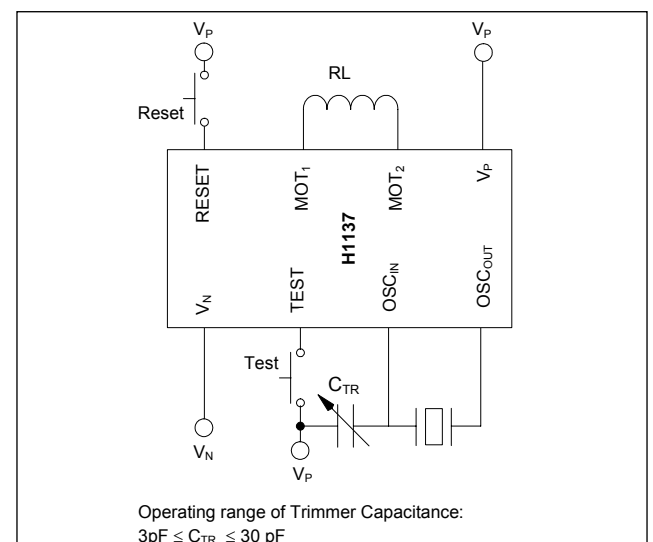
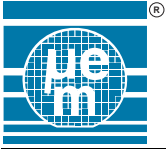

Fig. 5



H1137

Metal Mask Option Possibilities

Motor pulse and capacitance

| Sym- bol | Description | Range min. | Range max. | Range resolut. |
|------------------|---------------------------|---------------|------------------------------------|-------------------|
| TM | Motor pulse period | 2x1.00s | 2x60.00s | 1.00s |
| TM | Fast motor TEST | 2x31.25ms | 2x62.50ms | |
| tm | Motor pulse width | 0.9765ms | 14.65ms | 0.9765ms |
| C _{IN} | Oscillator input capacity | 2pF | C _{IN} + C _{OUT} | 1pF |
| C _{OUT} | Oscillator output capac. | 2.7pF | =35pF | 1pF |

Pad options

| Sym- bol | Description | Pad Layout 1 | Pad Layout 2 | Pad Layout 3 |
|-------------|-------------|-----------------|-----------------|-----------------|
| TEST | Pad TEST | Pad 10 | Pad 2 | Pad 8 |
| RESET | Pad RESET | Pad 8 Pad 2 | Pad 8 Pad 10 | Pad 2 Pad 10 |
| | | not used | not used | not used |

Possible versions Option list (supply voltage -1.55V)

| Version | Options | | | | | | | | | | | | | | Com- patible EURO- SIL E1208 | |
|----------|--------------|----------------------|--------------------|-------------------------|--------------------------|-----------------|-------|-------------------|--------------------|----------------|------------------|------------------|-------|--------|--|--|
| | Motor Output | | | Integrated capacitor | | Designation pad | | | | | | | | | | |
| | Period s | Pulse Width ms | Fast Mode ms | OSC _{IN} pF | OSC _{OUT} pF | Pad 1 | Pad 2 | Pad 3 | Pad 4 | Pad 5 | Pad 6 | Pad 7 | Pad 8 | Pad 10 | | |
| H1137V01 | 2x12 | 6.8 | 2x62.5 | 2 | 18 | V _N | - | OSC _{IN} | OSC _{OUT} | V _P | MOT ₂ | MOT ₁ | RESET | TEST | A | |
| H1137V02 | 2x1 | 3.9 | 2x62.5 | 2 | 14 | V _N | TEST | OSC _{IN} | OSC _{OUT} | V _P | MOT ₂ | MOT ₁ | RESET | - | B | |
| H1137V03 | 2x10 | 7.8 | 2x62.5 | 2 | 22 | V _N | RESET | OSC _{IN} | OSC _{OUT} | V _P | MOT ₂ | MOT ₁ | TEST | - | C | |
| H1137V04 | 2x12 | 5.9 | 2x62.5 | 2 | 14 | V _N | TEST | OSC _{IN} | OSC _{OUT} | V _P | MOT ₂ | MOT ₁ | RESET | - | D | |
| H1137V05 | 2x1 | 6.8 | 2x62.5 | 2 | 14 | V _N | TEST | OSC _{IN} | OSC _{OUT} | V _P | MOT ₂ | MOT ₁ | RESET | - | E | |
| H1137V07 | 2x10 | 5.9 | 2x62.5 | 2 | 16 | V _N | RESET | OSC _{IN} | OSC _{OUT} | V _P | MOT ₂ | MOT ₁ | TEST | - | G | |
| H1137V08 | 2x12 | 6.8 | 2x62.5 | 2 | 14 | V _N | TEST | OSC _{IN} | OSC _{OUT} | V _P | MOT ₂ | MOT ₁ | RESET | - | H | |
| H1137V09 | 2x1 | 7.8 | 2x62.5 | 2 | 20 | V _N | TEST | OSC _{IN} | OSC _{OUT} | V _P | MOT ₂ | MOT ₁ | RESET | - | IS | |
| H1137V10 | 2x1 | 3.9 | 2x62.5 | 2 | 14 | V _N | - | OSC _{IN} | OSC _{OUT} | V _P | MOT ₂ | MOT ₁ | RESET | TEST | K | |
| H1137V11 | 2x12 | 5.9 | 2x62.5 | 2 | 14 | V _N | - | OSC _{IN} | OSC _{OUT} | V _P | MOT ₂ | MOT ₁ | RESET | TEST | L | |
| H1137V12 | 2x1 | 6.8 | 2x62.5 | 2 | 14 | V _N | - | OSC _{IN} | OSC _{OUT} | V _P | MOT ₂ | MOT ₁ | RESET | TEST | M | |
| H1137V13 | 2x12 | 6.8 | 2x62.5 | 2 | 14 | V _N | - | OSC _{IN} | OSC _{OUT} | V _P | MOT ₂ | MOT ₁ | RESET | TEST | N | |
| H1137V14 | 2x1 | 4.9 | 2x62.5 | 2 | 16 | V _N | TEST | OSC _{IN} | OSC _{OUT} | V _P | MOT ₂ | MOT ₁ | RESET | - | O | |
| H1137V15 | 2x1 | 6.8 | 2x62.5 | 2 | 20 | V _N | TEST | OSC _{IN} | OSC _{OUT} | V _P | MOT ₂ | MOT ₁ | RESET | - | P | |
| H1137V16 | 2x1 | 5.9 | 2x62.5 | 2 | 14 | V _N | TEST | OSC _{IN} | OSC _{OUT} | V _P | MOT ₂ | MOT ₁ | RESET | - | S | |
| H1137V17 | 2x5 | 5.9 | 2x62.5 | 2 | 14 | V _N | TEST | OSC _{IN} | OSC _{OUT} | V _P | MOT ₂ | MOT ₁ | RESET | - | T | |
| H1137V19 | 2x20 | 7.8 | 2x62.5 | 2 | 14 | V _N | TEST | OSC _{IN} | OSC _{OUT} | V _P | MOT ₂ | MOT ₁ | RESET | - | V | |
| H1137V20 | 2x20 | 5.9 | 2x62.5 | 2 | 14 | V _N | TEST | OSC _{IN} | OSC _{OUT} | V _P | MOT ₂ | MOT ₁ | RESET | - | WA | |
| H1137V21 | 2x1 | 4.9 | 2x62.5 | 2 | 14 | V _N | TEST | OSC _{IN} | OSC _{OUT} | V _P | MOT ₂ | MOT ₁ | RESET | - | WB | |
| H1137V22 | 2x1 | 3.9 | 2x62.5 | 2 | 20 | V _N | TEST | OSC _{IN} | OSC _{OUT} | V _P | MOT ₂ | MOT ₁ | RESET | - | WD | |
| H1137V23 | 2x1 | 5.9 | 2x62.5 | 2 | 20 | V _N | TEST | OSC _{IN} | OSC _{OUT} | V _P | MOT ₂ | MOT ₁ | RESET | - | WE | |
| H1137V24 | 2x10 | 6.8 | 2x62.5 | 2 | 14 | V _N | TEST | OSC _{IN} | OSC _{OUT} | V _P | MOT ₂ | MOT ₁ | RESET | - | WF | |
| H1137V25 | 2x5 | 7.8 | 2x62.5 | 2 | 20 | V _N | TEST | OSC _{IN} | OSC _{OUT} | V _P | MOT ₂ | MOT ₁ | RESET | - | WG | |
| H1137V26 | 2x20 | 6.8 | 2x31.25 | 2 | 14 | V _N | TEST | OSC _{IN} | OSC _{OUT} | V _P | MOT ₂ | MOT ₁ | RESET | - | WH | |
| H1137V27 | 2x0.5 | 4.9 | 2x62.5 | 2 | 14 | V _N | TEST | OSC _{IN} | OSC _{OUT} | V _P | MOT ₂ | MOT ₁ | RESET | - | | |
| H1137V28 | 2x40 | 5.9 | 2x62.5 | 2 | 14 | V _N | TEST | OSC _{IN} | OSC _{OUT} | V _P | MOT ₂ | MOT ₁ | RESET | - | | |
| H1137V51 | 2x5 | 4.9 | 2x31.25 | 2 | 23 | V _N | TEST | OSC _{IN} | OSC _{OUT} | V _P | MOT ₂ | MOT ₁ | RESET | - | | |
| H1137V52 | 2x5 | 7.8 | 2x31.25 | 2 | 23 | V _N | TEST | OSC _{IN} | OSC _{OUT} | V _P | MOT ₂ | MOT ₁ | RESET | - | | |
| H1137V53 | 2x1 | 3.9 | 2x31.25 | 2 | 23 | V _N | TEST | OSC _{IN} | OSC _{OUT} | V _P | MOT ₂ | MOT ₁ | RESET | - | | |
| H1137V54 | 2x20 | 4.9 | 2x31.25 | 2 | 23 | V _N | TEST | OSC _{IN} | OSC _{OUT} | V _P | MOT ₂ | MOT ₁ | RESET | - | | |
| H1137V58 | 2x10 | 4.9 | 2x31.25 | 2 | 25 | V _N | RESET | OSC _{IN} | OSC _{OUT} | V _P | MOT ₂ | MOT ₁ | TEST | - | | |

Ordering Information

For other versions, please contact EM Microelectronic-Marin S.A.
Please make sure to give the complete part number when ordering.

H1137 WW 11 - %%%

Customer Version:
customer-specific number
given by EM Microelectronic

Thickness:
11 = 11 mils (280um)
27 = 27 mils (686um)
(for other thickness, contact EM)

Die form:
WW = Wafer
WS = Sawn Wafer/Frame
WP = Waffle Pack

Chip Information

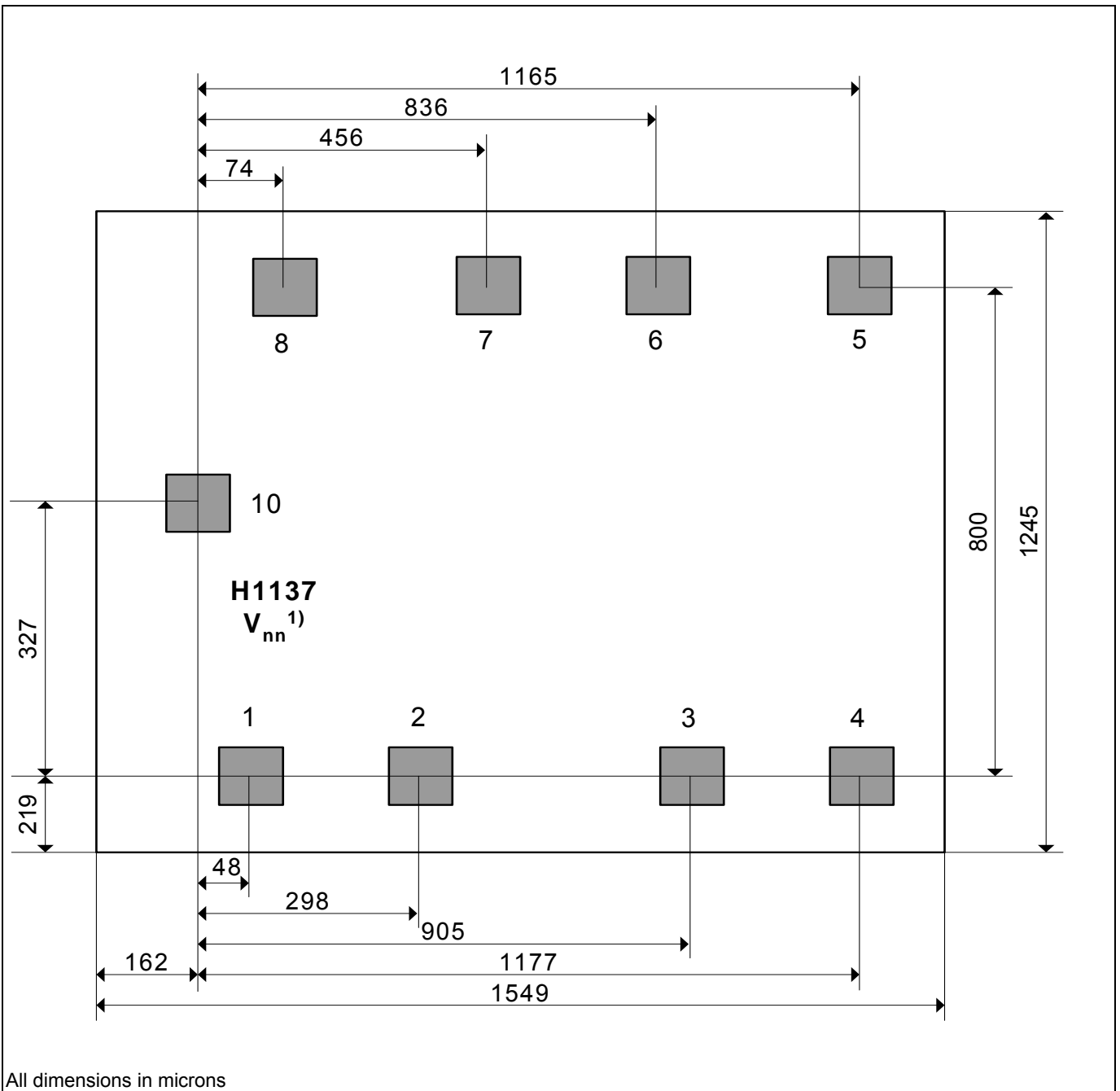

¹⁾ nn stands for the version

Fig. 6

EM Microelectronic-Marín SA cannot assume responsibility for use of any circuitry described other than circuitry entirely embodied in an EM Microelectronic-Marín SA product. EM Microelectronic-Marín SA reserves the right to change the circuitry and specifications without notice at any time. You are strongly urged to ensure that the information given has not been superseded by a more up-to-date version.

© EM Microelectronic-Marín SA, 11/04, Rev. A