

## Descriptions

The S1117 series of positive adjustable and fixed regulators are designed to provide 1A with high efficiency. All internal circuitry is designed to operate down to 1.3V input to output differential. On-chip trimming adjusts reference voltage to 2%.

## Features

- Adjustable or Fixed output
- Output Current of 1A
- Low Dropout, 1.3V maximum at 1A Output Current
- Thermal Shutdown Protection
- Fast Transient Response

## Ordering Information

Type NO.	Marking	Package Code
S1117API/S1117xxPI	S1117□□PI/ S1117□□□PI	TO-220F
□□:Voltage Code (Aj : 1.25V, 15:1.5V,:18: 1.8V, 25:2.5V, 33:3.3V, 50:5.0V) □□□:Voltage Code (285:2.85V)		

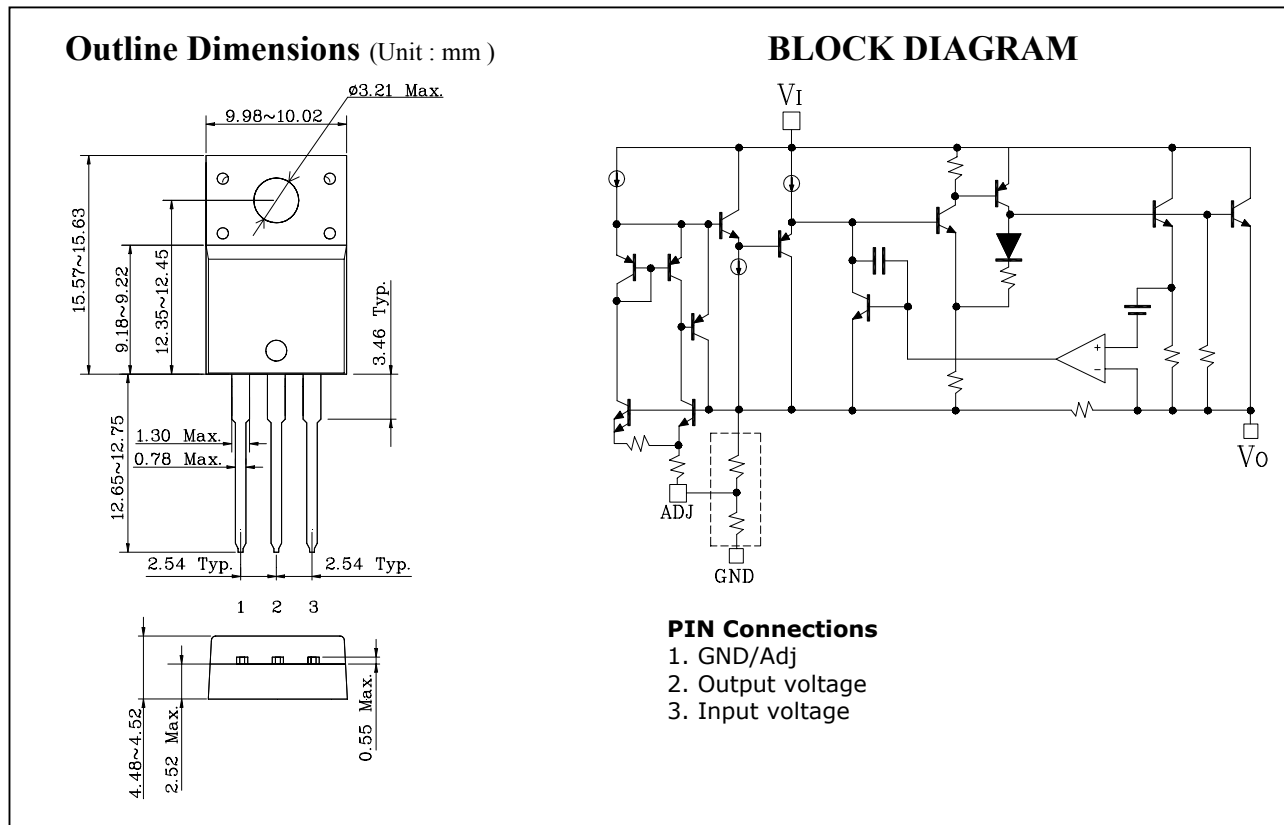

**Absolute Maximum Ratings****T<sub>a</sub>=25°C**

Characteristic	Symbol	Rating	Unit
Input voltage	V <sub>I</sub>	16	V
Power Dissipation	P <sub>D</sub>	2.0	W
Junction Temperature	T <sub>J</sub>	150	°C
Storage Temperature Range	T <sub>stg</sub>	-55 ~ 150	°C

**Device Selection Guide** (NOTE1)

Device	Output Voltage
S1117API	Adjustable
S1117-15PI	1.5V
S1117-18PI	1.8V
S1117-25PI	2.5V
S1117-285PI	2.85V
S1117-33PI	3.3V
S1117-50PI	5.0V

Note 1 : Other fixed versions are available V<sub>O</sub>=1.5V to 5V

## Electrical Characteristics

(Electrical Characteristics at  $T_j = 25^\circ\text{C}$  and  $V_I = (V_O + 1.5\text{V})$ ,  $I_L = 10\text{ mA}$ ,  $C_O = 10\ \mu\text{F}$  unless otherwise specified.)

Characteristic	Symbol	Device	Test Condition	Min	Typ	Max	Unit	
Output Voltage	$V_O$	S1117A	$V_I = (V_O + 1.5\text{V}), I_O = 10\text{ mA}$		1.225	1.275	V	
			$V_I = (V_O + 1.5\text{V})\text{ to }7\text{V}$ $I_O = 0\text{ to }1000\text{ mA}$	*	1.200	1.300		
		S1117-15	$V_I = (V_O + 1.5\text{V}), I_O = 10\text{ mA}$		1.470	1.530		
			$V_I = (V_O + 1.5\text{V})\text{ to }7\text{V}$ $I_O = 0\text{ to }1000\text{ mA}$	*	1.440	1.560		
		S1117-18	$V_I = (V_O + 1.5\text{V}), I_O = 10\text{ mA}$		1.764	1.836		
			$V_I = (V_O + 1.5\text{V})\text{ to }7\text{V}$ $I_O = 0\text{ to }1000\text{ mA}$	*	1.728	1.872		
		S1117-25	$V_I = (V_O + 1.5\text{V}), I_O = 10\text{ mA}$		2.450	2.550		
			$V_I = (V_O + 1.5\text{V})\text{ to }7\text{V}$ $I_O = 0\text{ to }1000\text{ mA}$	*	2.400	2.600		
		S1117-285	$V_I = (V_O + 1.5\text{V}), I_O = 10\text{ mA}$		2.793	2.907		
			$V_I = (V_O + 1.5\text{V})\text{ to }7\text{V}$ $I_O = 0\text{ to }1000\text{ mA}$	*	2.736	2.964		
		S1117-33	$V_I = (V_O + 1.5\text{V}), I_O = 10\text{ mA}$		3.234	3.366		
			$V_I = (V_O + 1.5\text{V})\text{ to }7\text{V}$ $I_O = 0\text{ to }1000\text{ mA}$	*	3.168	3.432		
		S1117-50	$V_I = (V_O + 1.5\text{V}), I_O = 10\text{ mA}$		4.900	5.100		
			$V_I = (V_O + 1.5\text{V})\text{ to }7\text{V}$ $I_O = 0\text{ to }1000\text{ mA}$	*	4.800	5.200		
Line Regulation (Note2)	$\Delta V_{O(\Delta V_I)}$	All	$1.5\text{V} \leq V_I - V_O \leq 7\text{V}$ $I_O = 10\text{ mA}$	-	5	10	mV	
Load Regulation (Note2)	$\Delta V_{O(\Delta I_L)}$	All	$V_I = (V_O + 1.5\text{V})$ $I_O = 10\text{ mA} \sim 1000\text{ mA}$	-	10	30	mV	
Quiescent Current	$I_{QC}$	All	$V_I = V_O + 1.5\text{V}$ $V_{ADJ} = 0\text{V}$	*	-	7	13	mA
Minimum Load Current	$I_{L(\text{MIN})}$	S1117A	$V_I = (V_O + 1.5\text{V}), V_O = 0\text{V}$	*	-	3	7	mA
Adjust Pin Current	$I_{ADJ}$	S1117A	$V_I = (V_O + 1.5\text{V})\text{ to }7\text{V}$ $I_O = 10\text{ mA}$	*	-	55	90	$\mu\text{A}$
Dropout Voltage (Note4)	$V_{\text{DROP}}$	All	$I_O = 1000\text{ mA}$	*	-	1.2	1.3	V
Ripple Rejection (Note3)	RR	All	$V_I - V_O = 1.5\text{V}, I_O = 1000\text{ mA}$ $V_{\text{Ripple}} = 1\text{V}_{\text{P-P}}, f = 120\text{ Hz}$		60	72	-	dB
Current Limit	$I_{\text{LIMIT}}$	All	$(V_I - V_O) = 1.5\text{V}$	*	1			A

The \* denotes the specifications which apply over the full temperature range.

Note 2: Low duty pulse testing with Kelvin connections required.

Note 3: 120 Hz input ripple ( $C_{ADJ}$  for ADJ=25  $\mu\text{F}$ )

Note 4:  $\Delta V_O = 1\%$

## ■ Typical Applications

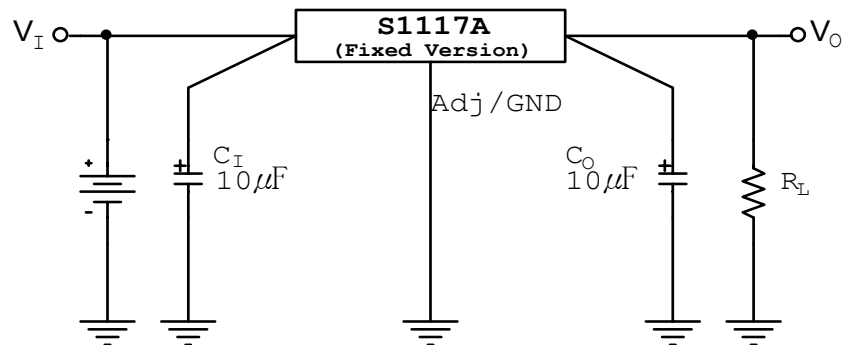
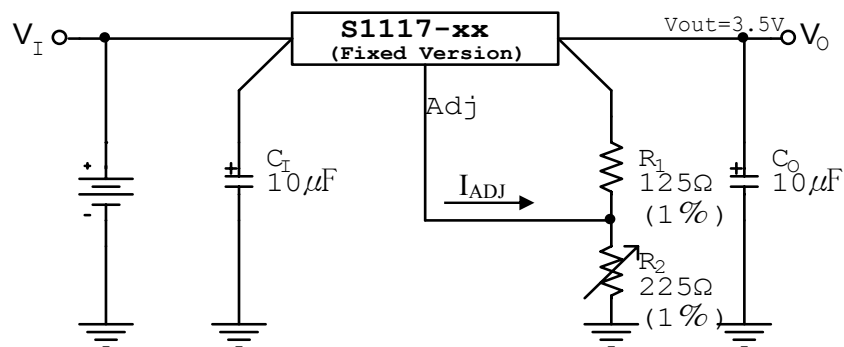

Fig. 1 Fixed Voltage Regulator



$$V_O = V_{ADJ} * (1 + R_2/R_1) + I_{ADJ} * R_2$$

Fig. 2 Adjustable Voltage Regulator

Notes:

- 1)  $C_I$  needed if device is far from filter capacitors
- 2)  $C_O$  minimum value required for stability

Electrical Characteristic Curves

Fig. 3  $V_{DROP}$  vs.  $I_O$

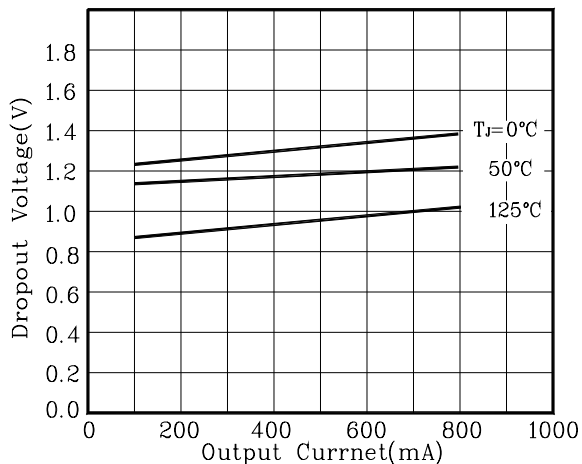

Fig. 4  $\Delta V_O$  vs.  $T_a$

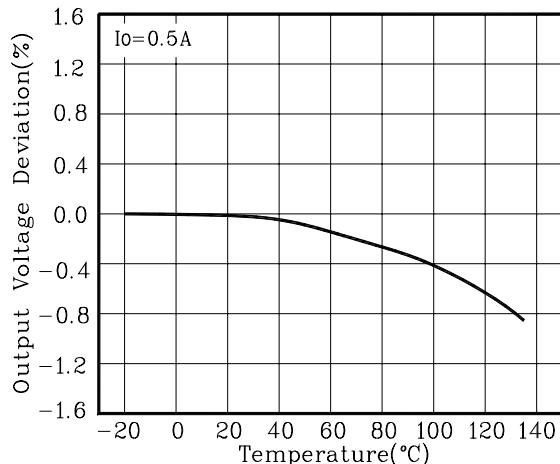

Fig. 5 RR vs. Frequency

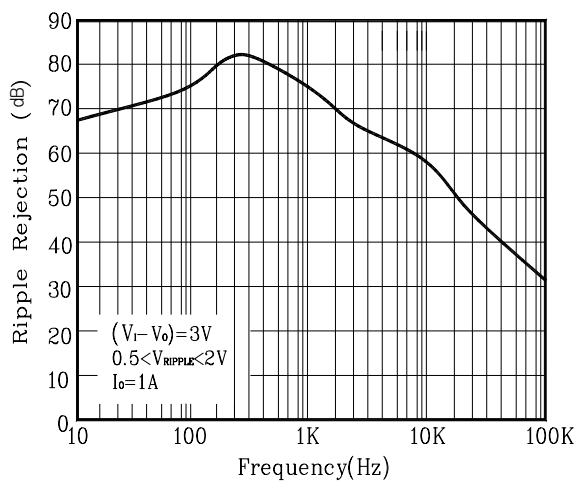

Fig. 6 Temperature Stability

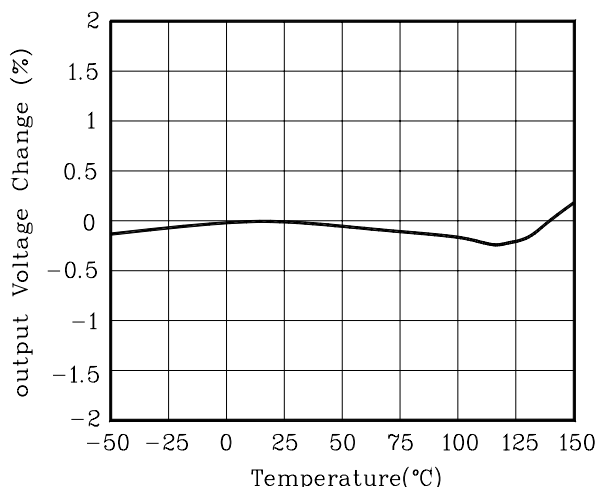

Fig. 7  $I_{ADJ}$  vs.  $T_a$

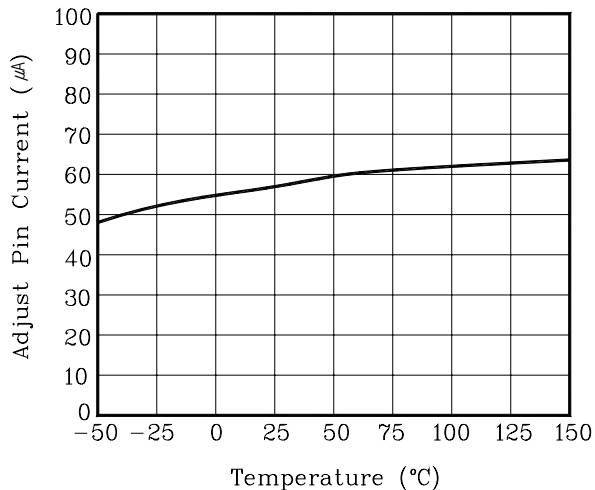
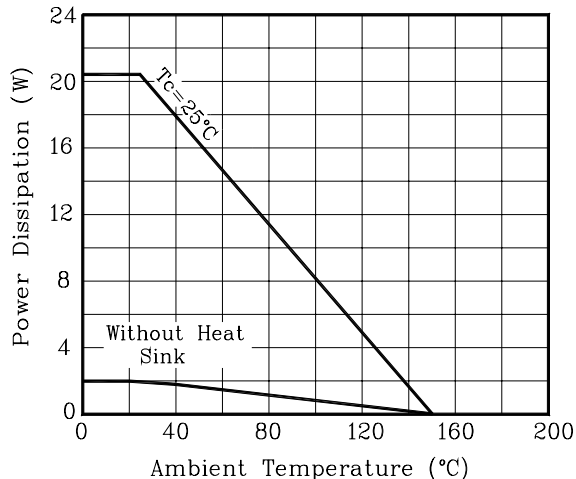

Fig. 8  $P_D$  vs.  $T_a$



**These AUK Corp. products are intended for usage in general electronic equipment (Office and communication equipment, measuring equipment, domestic electrification, etc.) Please make sure that you consult with us before you use these AUK products in equipments which require high quality and/or reliability, and in equipments which could have major impact to the welfare of human life(atomic energy control, airplane, spaceship, traffic signal, combustion central, all types of safety device, etc.) AUK cannot accept liability to any damage which may occur in case these AUK products were used in the mentioned equipments without prior consultation**