



# TAI-SAW TECHNOLOGY CO., LTD.

No. 3, Industrial 2nd Rd., Ping-Chen Industrial District,  
Taoyuan, 324, Taiwan, R.O.C.

TEL: 886-3-4690038 FAX: 886-3-4697532

E-mail: [tstsales@mail.taisaw.com](mailto:tstsales@mail.taisaw.com) Web: [www.taisaw.com](http://www.taisaw.com)

## Approval Sheet For Product Specification

Issued Date:

Product Name: 61.38MHz IF SAW Filter (BW=1.8MHz)

TST Parts No.: TB0728A

Customer Parts No.: \_\_\_\_\_

Company: _____
Division: _____
Approved by : _____
Date: _____

Checked by: Andy Yu *Andy*

Approval by: Francis Chen *(Signature)*

Date: 2009/03/10



# TAI-SAW TECHNOLOGY CO., LTD.

No.3, Industrial 2nd Rd., Ping-Chen Industrial District, Taoyuan, Taiwan, R.O.C.

TEL: 886-3-4690038 FAX: 886-3-4697532

E-mail: [tstsales3@mail.taisaw.com](mailto:tstsales3@mail.taisaw.com) Web: [www.taisaw.com](http://www.taisaw.com)

SAW Filter 61.38MHz (SMD 13.3×6.5 mm)

Model No.: TB0728A

Rev. No.:1.0

## A. MAXIMUM RATING:

1. Input Power Level: 10 dBm
2. Operating Temperature: -20°C to +80°C
3. Storage Temperature: -40°C to +85°C

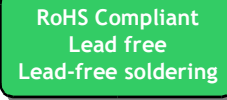

## B. Characteristics :

Ambient Temperature: 25 °C

Item	Unit	Min.	Type.	Max.
Center frequency, <b>Fc</b>	MHz	-	61.38	-
Insertion Loss, <b>IL</b>	dB	-	8.8	10.0
-1 dB Bandwidth	MHz	1.8	2.53	-
-3 dB Bandwidth	MHz	2.8	2.98	-
-40 dB Bandwidth	MHz	-	4.92	5.2
Amplitude Ripple <b>Fc±0.75MHz</b>	dB	-	0.5	1.0
Group-delay Ripple <b>Fc±0.75MHz</b>	dB	-	110	150
Relative Attenuation <b>1.0 ~ 57.38MHz</b>	dB	45	52	-
Relative Attenuation <b>65.38 ~150MHz</b>	dB	45	48	-
Temp Coefficient	ppm/K	-23		

### C. Frequency Characteristics :

(1) wide band Response:(span 50MHz)

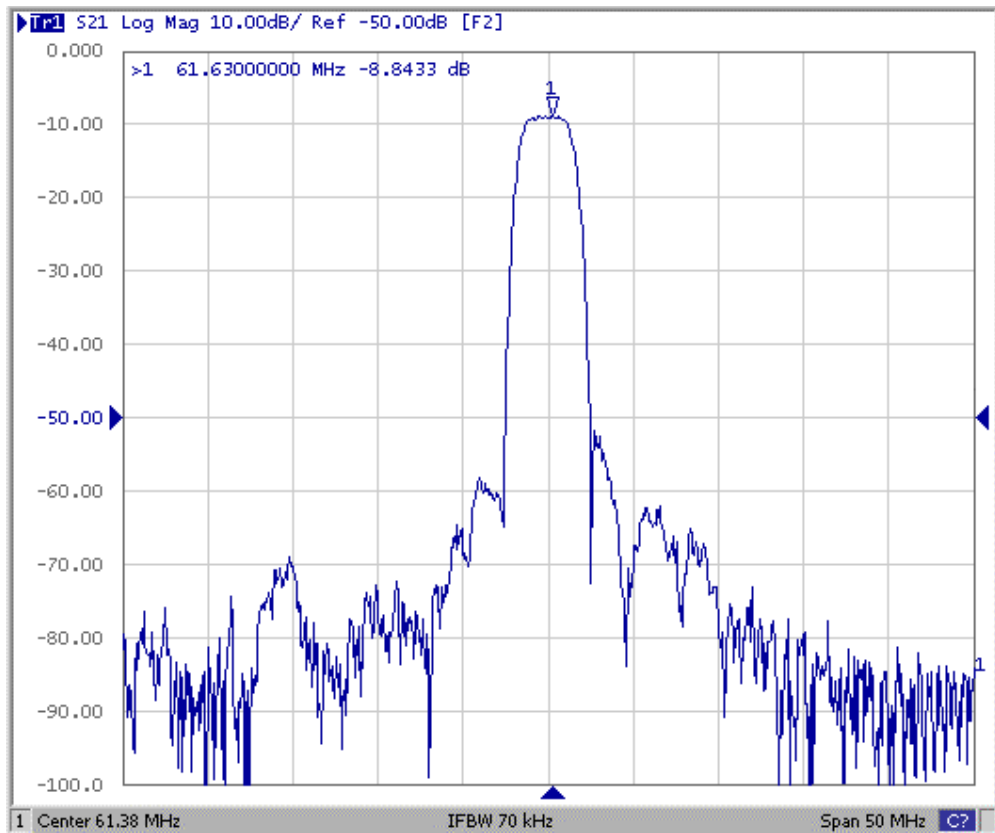

(2) Pass band Response and Group Delay Variation: (span 5MHz)

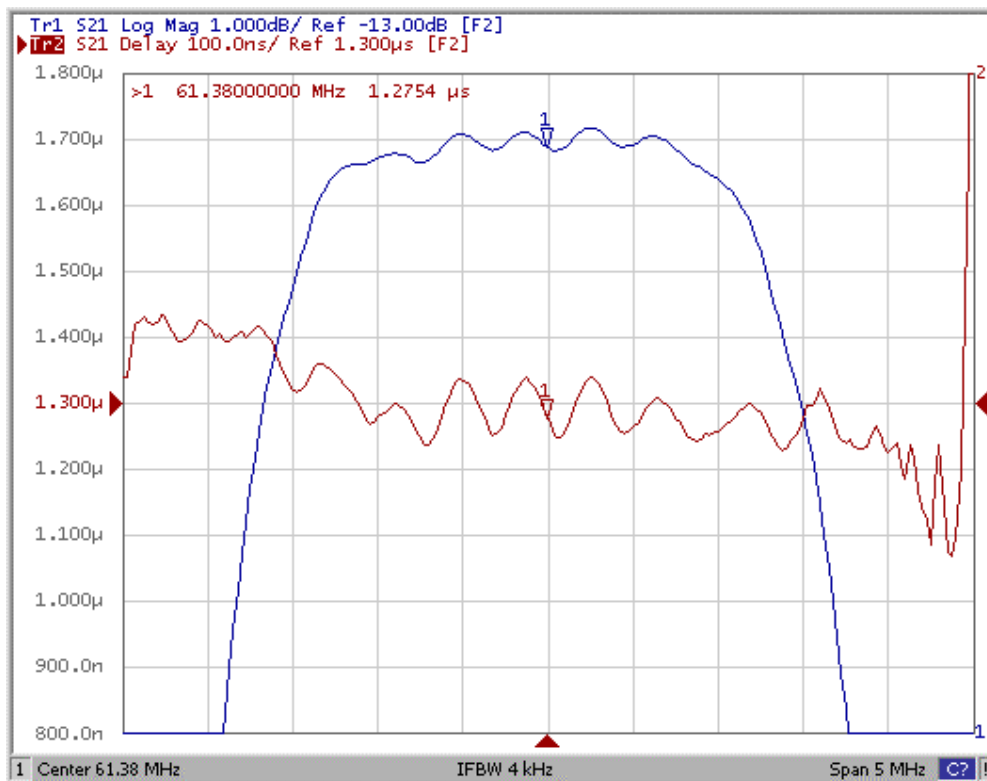

(3) S11 Smith-Chart: (span 50MHz)

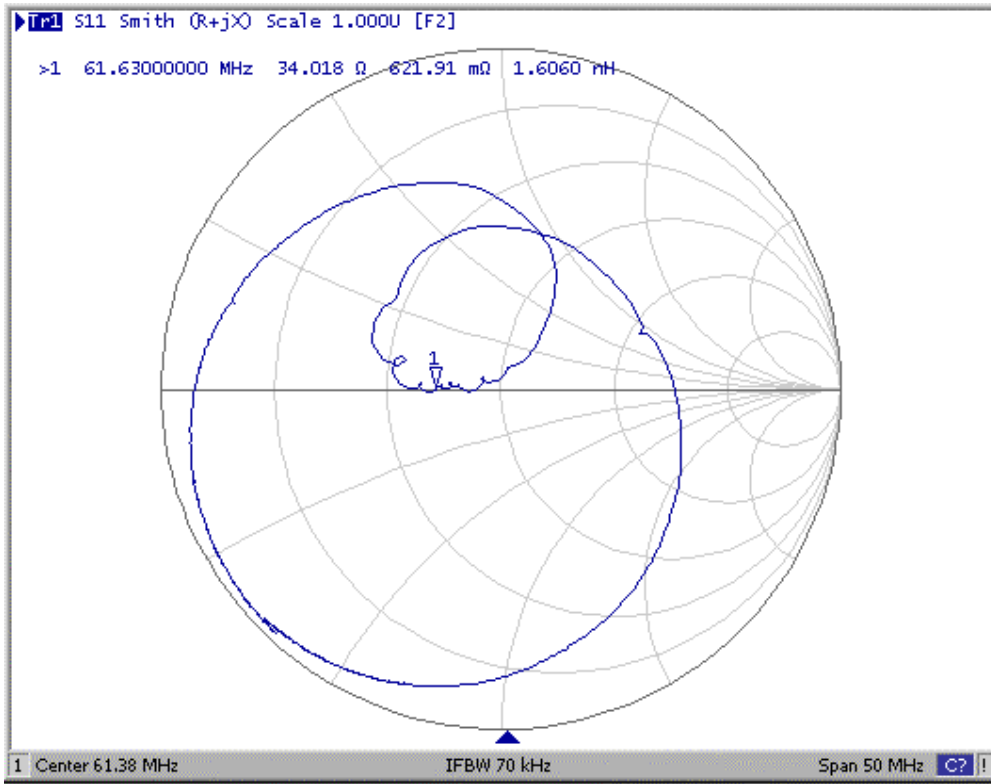

(4) S22 Smith-Chart: (span 50MHz)

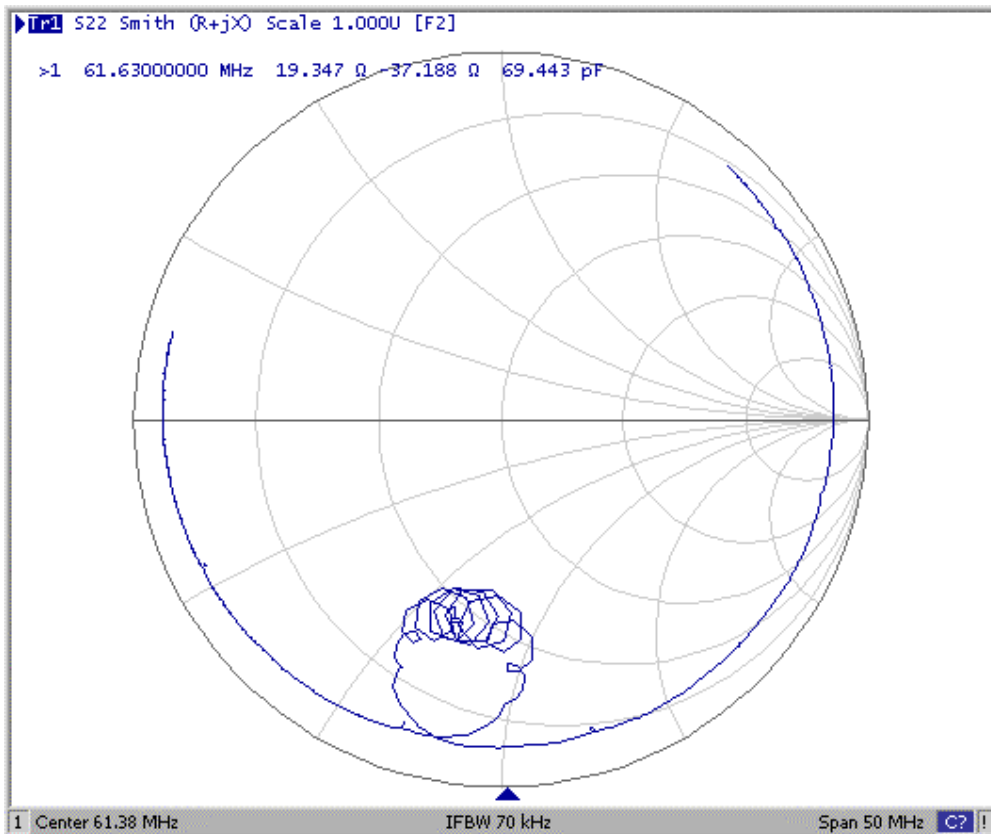

(5) wide band Response:(span 150MHz)

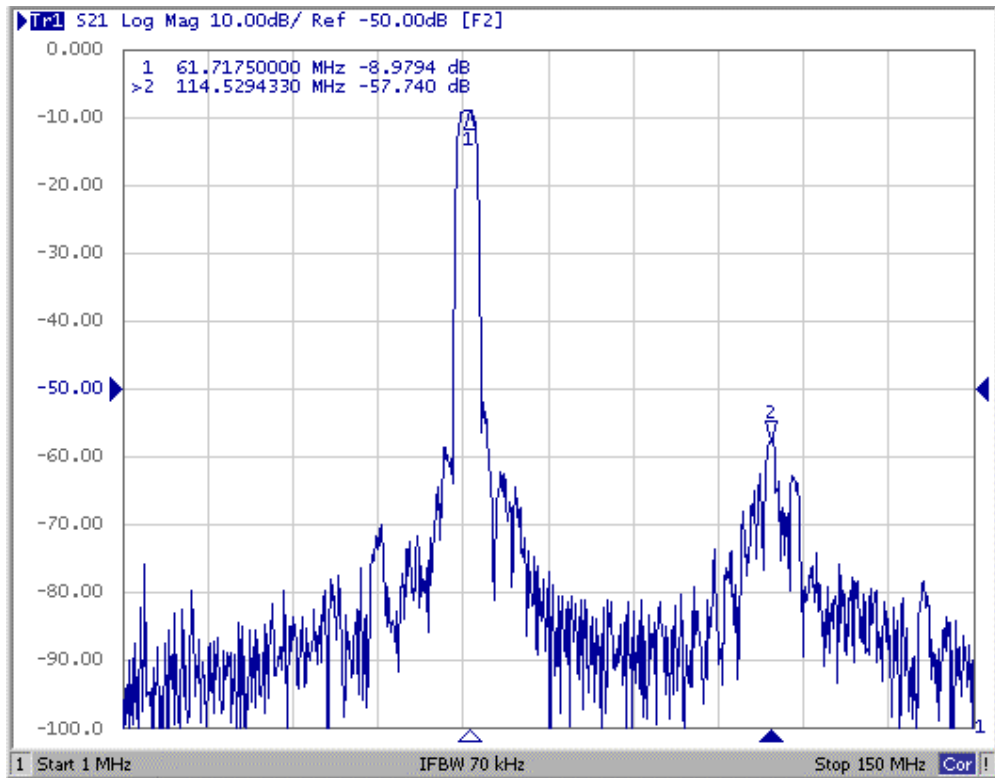

### D. Outline Drawing:

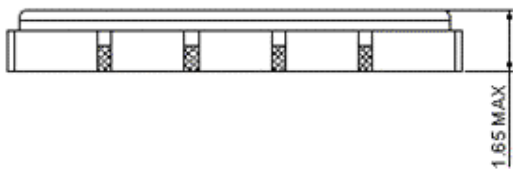
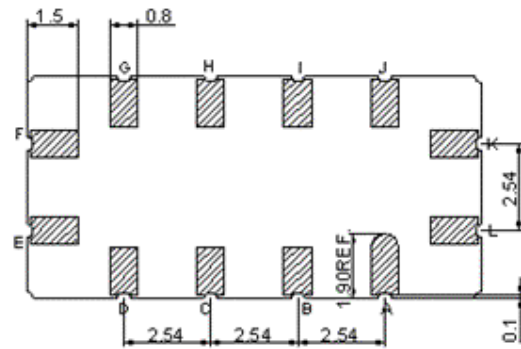
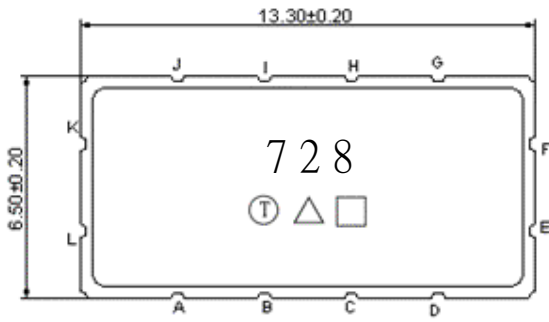

Pin K : RF Input

Pin E : RF Output

Pin A,B,C,D,F,G,H,I,J,L : Ground

Unit: mm

□ : Week Code (Follow the table from planner each year)

△ : Product / Year Code

Year	2005 2009	2006 2010	2007 2011	2008 2012
Product Code	B	b	<u>B</u>	<u>b</u>

### E. PCB Footprint:

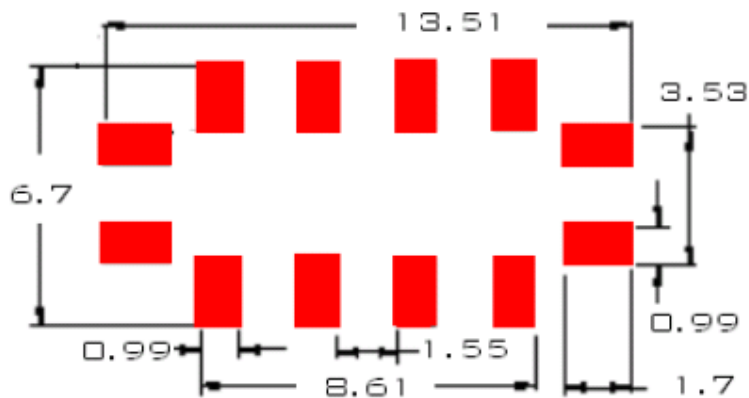

### F. Matching Circuit:

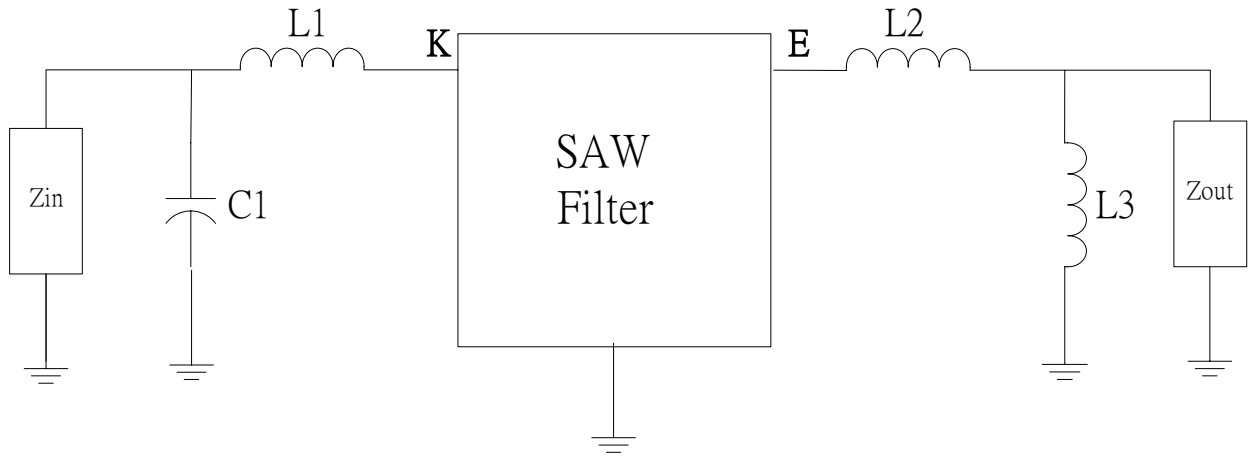

$$Z_{in} = Z_{out} = 50 \text{ ohm}$$

$$L1 = 180 \text{ nH}, C1 = 110 \text{ pF}, L2 = 82 \text{ nH}, L3 = 220 \text{ nH}$$

### G. Packing:

(1). REEL DIMENSION:

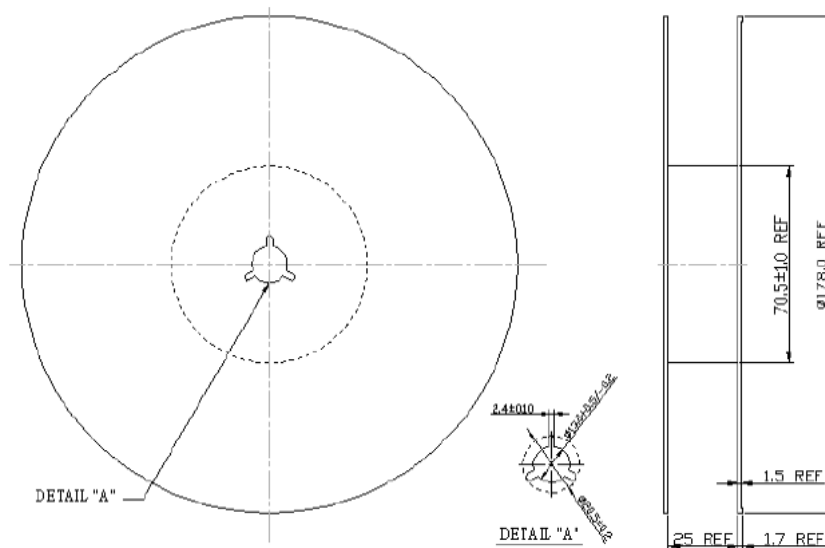

(2). TYPE DIMENSION:

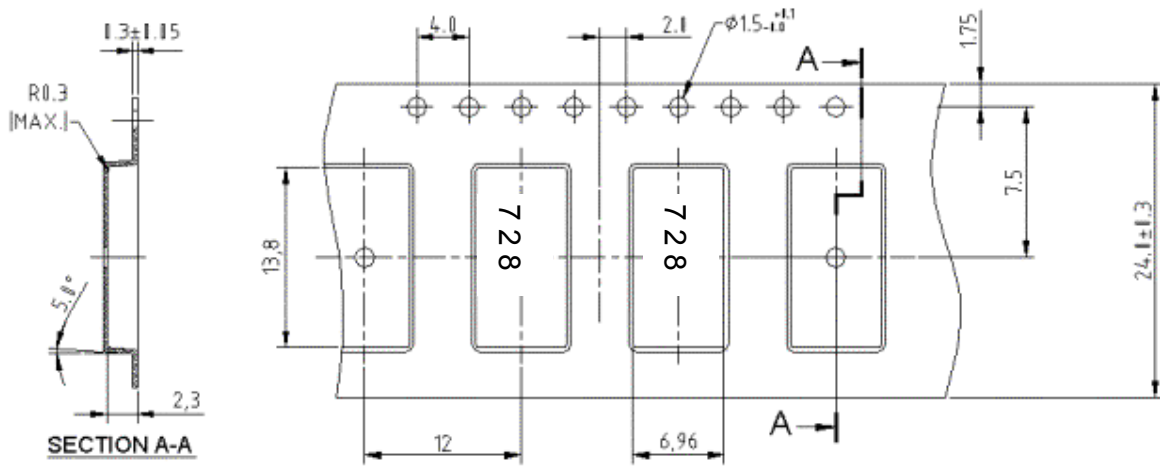

H. Recommended Reflow Profile:

