



TAI-SAW TECHNOLOGY CO., LTD.

No. 3, Industrial 2nd Rd., Ping-Chen Industrial District,
Tao-Yuan, 324, Taiwan, R.O.C.

TEL: 886-3-4690038 FAX: 886-3-4697532

E-mail: tstsales@mail.taisaw.com Web: www.taisaw.com

Approval Sheet for Product Specification

Issued Date:

Product Name: 490MHz IF SAW Filter (BW=15 MHz)

TST Parts No.: TB0716A

Customer Parts No.: _____

Company: _____
Division: _____
Approved by : _____
Date: _____

Checked by: Andy Yu *Andy*

Approval by: Francis Chen *[Signature]*

Date: 03/10/2009



TAI-SAW TECHNOLOGY CO., LTD.

No.3, Industrial 2nd Rd., Ping-Chen Industrial District, Taoyuan, Taiwan, R.O.C.

TEL: 886-3-4690038

FAX: 886-3-4697532

E-mail: tstsales3@mail.taisaw.com Web: www.taisaw.com

SAW Filter 490MHz (TO39)

MODEL NO.: TB0716A

Rev. NO. 1.0

A. MAXIMUM RATING:

1. Input Power Level: 10 dBm
2. Operating Temperature: -20 °C ~ +70°C
3. Storage Temperature: -40 °C ~ +85 °C

RoHS Compliant
Lead free
Lead-free soldering

B. Characteristics :

Ambient Temperature: 25 °

Characteristics	Value			Note
	Min.	Typ.	Max.	
Center frequency F_C MHz	-	490	-	-
Minimum Insertion loss I.L. dB	-	11.8	13.0	-
3 dB Bandwidth MHz	15.0	16.1	-	-
30 dB Bandwidth	-	25.8	27.0	-
Amplitude Ripple ($F_C \pm 5.0\text{MHz}$) dB	-	0.6	1.0	-
Group-delay Ripple ($F_C \pm 6.0\text{MHz}$) nsec	-	25	40	-
Temp Coefficient ppm/° C	-	-18	-	-
Attenuation (Reference level from Minimum insertion loss)				
506MHz dB	30	45	-	-

C.FREQUENCY CHARACTERISTICS:

(1) S21 Response:(span 100MHz)

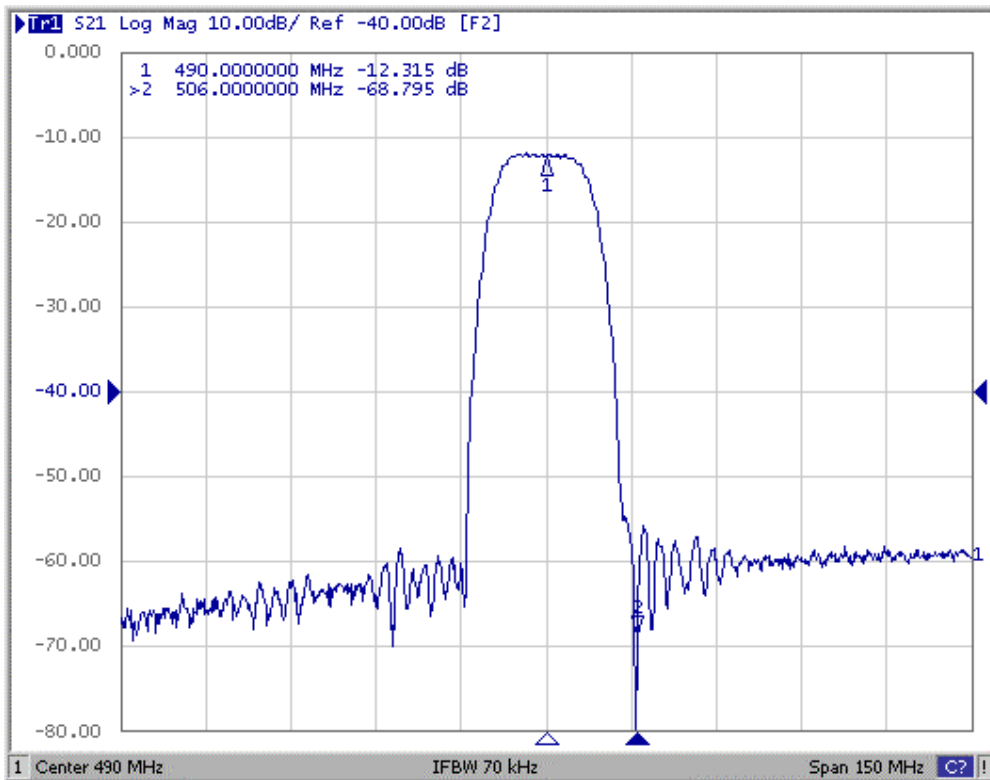

(2) Passband of Response: (span: 20MHz)

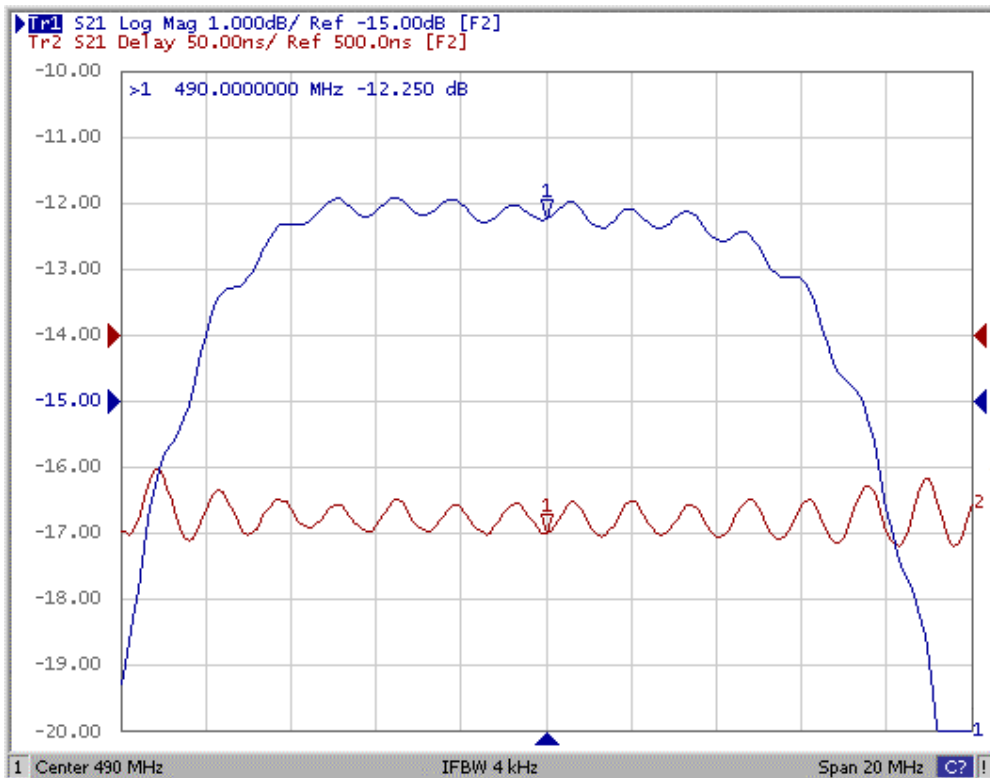

(3) S11 Smith Chart: (span 150MHz)

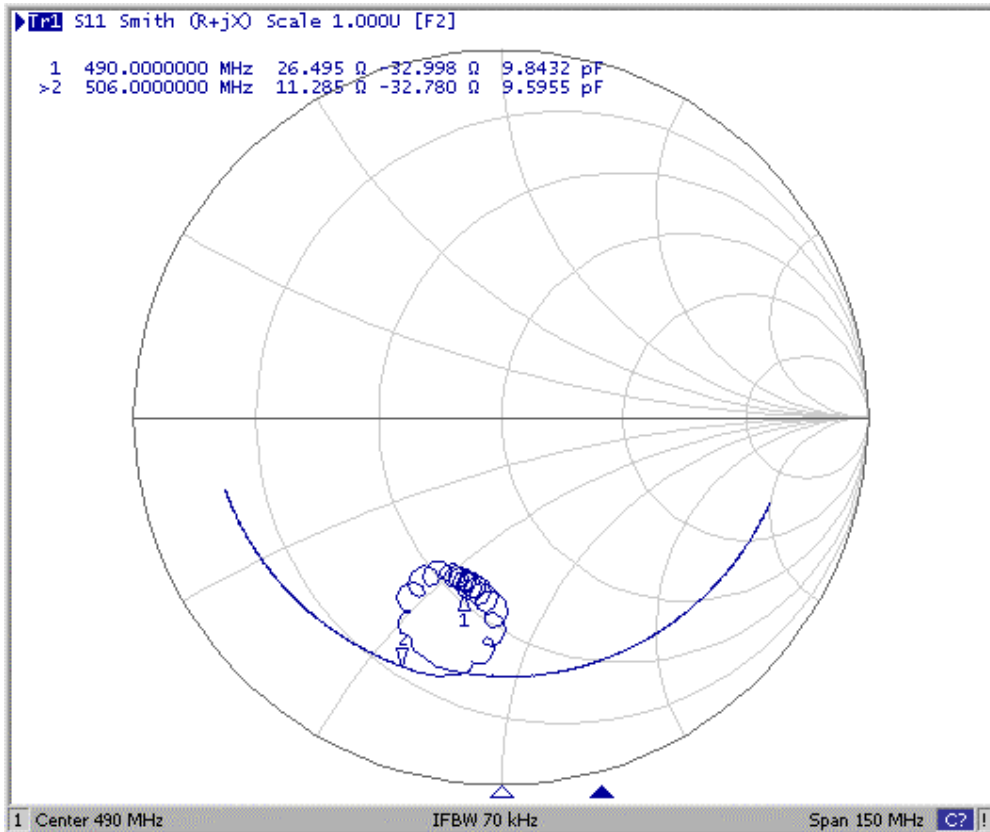

(4) S22 Smith Chart: (span 150MHz)

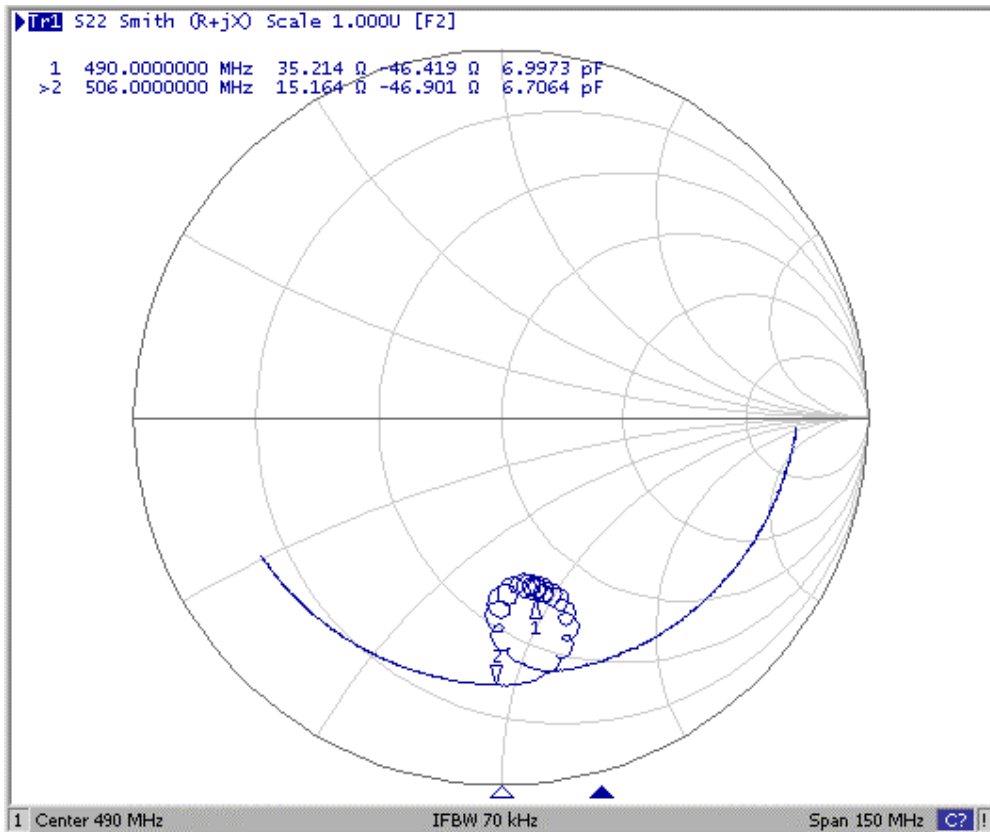

D. TEST CIRCUIT:

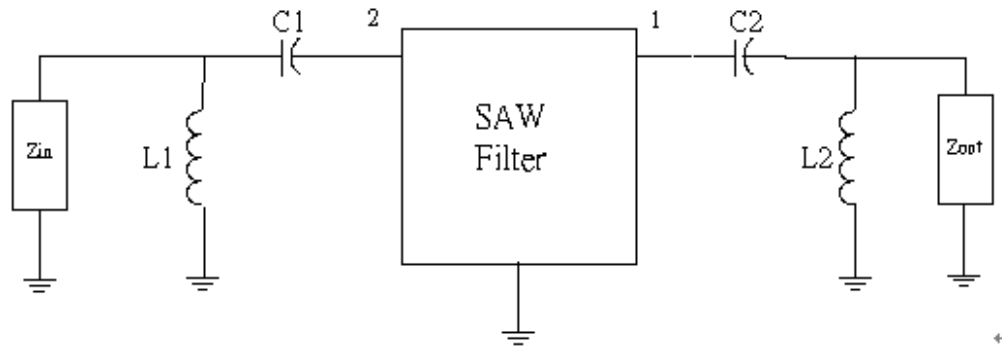

Zin and Zout are 50Ω

L1=12nH, C1=15p, L2=12nH, C1=18p,

E. OUTLINE DRAWING:

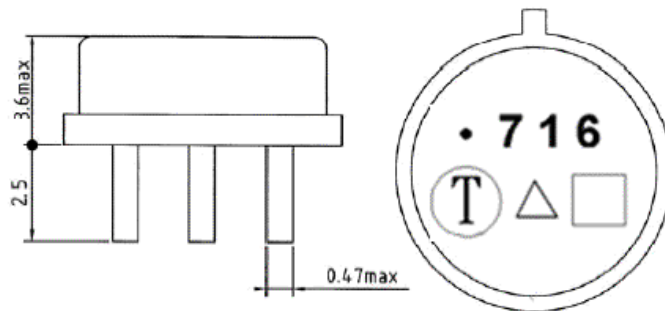

Pin 3: RF input

Pin 1: RF output

Pin 2, 4: Case Ground

□ : Week Code (Follow the table from planner each year) (週碼)

Unit : mm

△ : Product / Year Code (年碼)

Year	2005 2009	2006 2010	2007 2011	2008 2012
Product Code	B	b	<u>B</u>	<u>b</u>

F. Recommended Reflow Profile:

