



TAI-SAW TECHNOLOGY CO., LTD.

No. 3, Industrial 2nd Rd., Ping-Chen Industrial District,
Taoyuan, 324, Taiwan, R.O.C.

TEL: 886-3-4690038 FAX: 886-3-4697532

E-mail: ttsales@mail.taisaw.com Web: www.taisaw.com

Approval Sheet For Product Specification

Issued Date:

Product Name: IF SAW Filter 464 MHz(SMD 7.0X5.0mm)

TST Parts No.:TB0459A

Customer Parts No.: _____

Company: _____
Division: _____
Approved by : _____
Date: _____

Checked by: _____ Andy Lee

Approval by: _____ Francis Chen

Date: _____ 2008/01/28



TAI-SAW TECHNOLOGY CO., LTD.

No. 3, Industrial 2nd Rd., Ping-Chen Industrial District,
Taoyuan, 324, Taiwan, R.O.C.

TEL: 886-3-4690038 FAX: 886-3-4697532

E-mail: tstsales@mail.taisaw.com Web: www.taisaw.com

IF SAW Filter 464 MHz SMD 7X5mm

MODEL NO.: TB0459A

Rev No.1

A. MAXIMUM RATING:

1. Operating Temperature: -40 °C ~ +85 °C
2. Storage Temperature: -40 °C ~ +85 °C
3. Input Power Level: 10 dBm

RoHS Compliant
Lead free
Lead-free soldering

B. Characteristics :

1. Ambient Temperature: 25 °C
2. Optimal Source Impedance(Balanced): 200 ohm
3. Optimal Load Impedance(Balanced): 200 ohm

Characteristics	Value			Note
	Min.	Typ.	Max.	
Center frequency F_C MHz	-	464	-	-
Minimum Insertion Loss dB	-	15.5	18.0	-
1dB Bandwidth MHz	5.45	5.52	-	-
3dB Bandwidth MHz	-	5.68	5.90	-
Passband Ripple ($F_c \pm 2.5\text{MHz}$) dB	-	1.2	1.5	-
Amplitude Ripple at any 26.875kHz adjacent segment within 5 MHz dB	-0.1	± 0.05	0.1	-
Amplitude Ripple at any 24.6875kHz adjacent segment within 5 MHz dB	-0.1	± 0.05	0.1	-
Phase Linearity at any 26.875kHz adjacent segment within 5 MHz Deg.	-1	± 0.46	1	-
Phase Linearity at any 24.6875kHz adjacent segment within 5 MHz Deg.	-1	± 0.43	1	-
Attenuation:(Reference level from minimum insertion loss)				dB
1) $F_c \pm 3\text{MHz}$ dB	-	8.9	-	-
2) $F_c \pm 3.5\text{MHz}$ dB	10	33	-	-
3) $F_c \pm 5\text{MHz}$ dB	36	42	-	-
4) 376MHz ~ 459 MHz dB	32	36	-	-
5) 469MHz ~ 552 MHz dB	34	39	-	-
Temp Coefficient ppm/° C ²	-0.036			-

C. Measurement Circuit:

(1) Single end 50 ohm to Single end 50 ohm

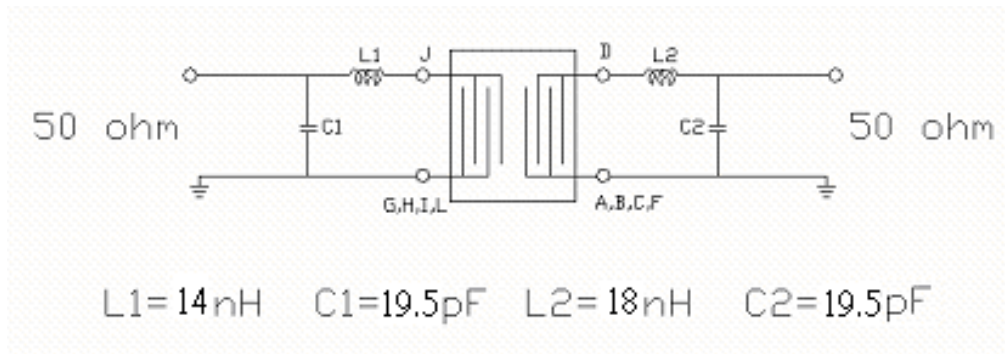

(2) Balanced 200 ohm to Balanced 200 ohm

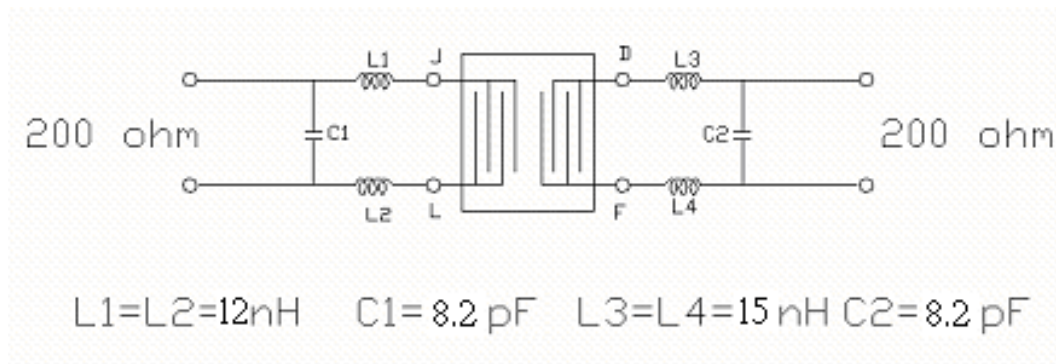

D. PCB FOOTPRINT:

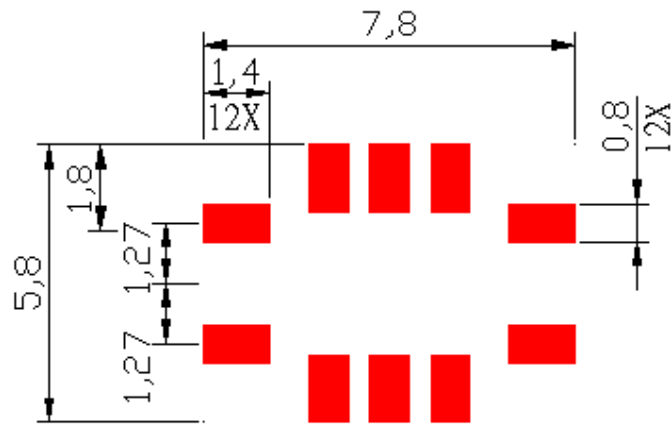

E. Frequency Characteristics :

(1) S21 Response

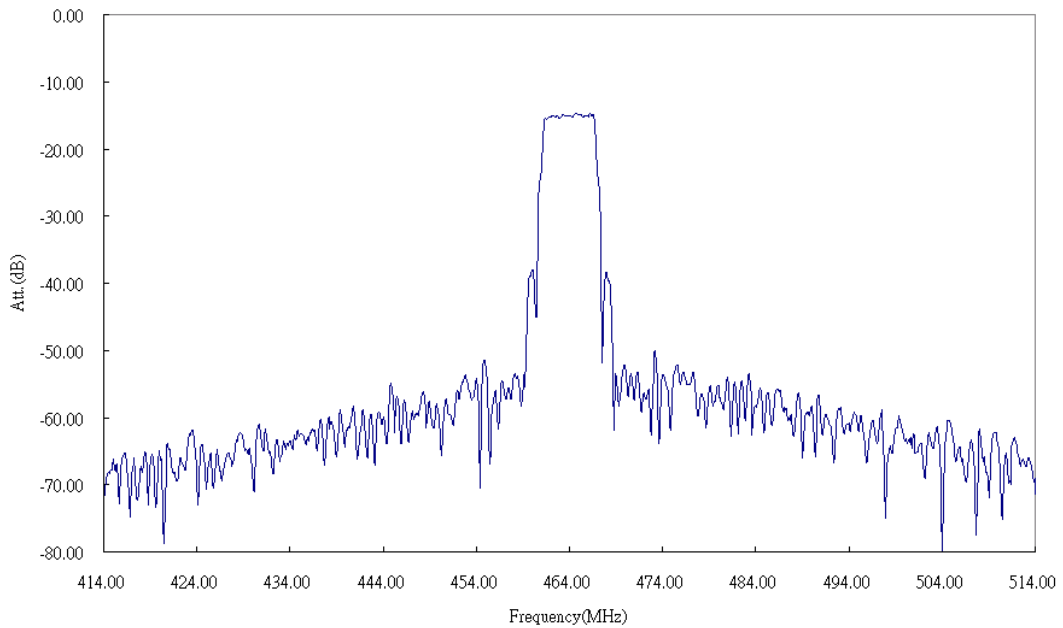

Fig1. Horizontal: 10MHz/Div Vertical: 10dB/Div

(2) Passband Ripple

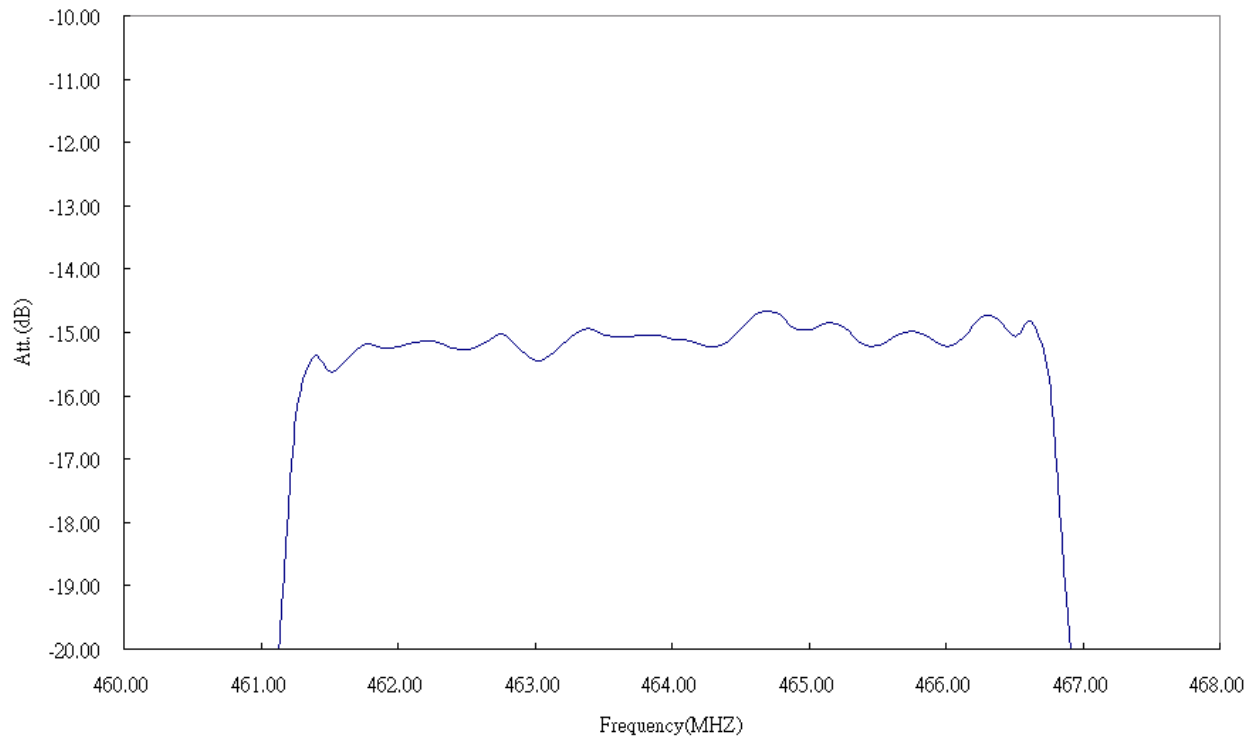

Fig2. Horizontal: 0.8 MHz/Div Vertical: 1dB/Div

(3) Group Delay ripple

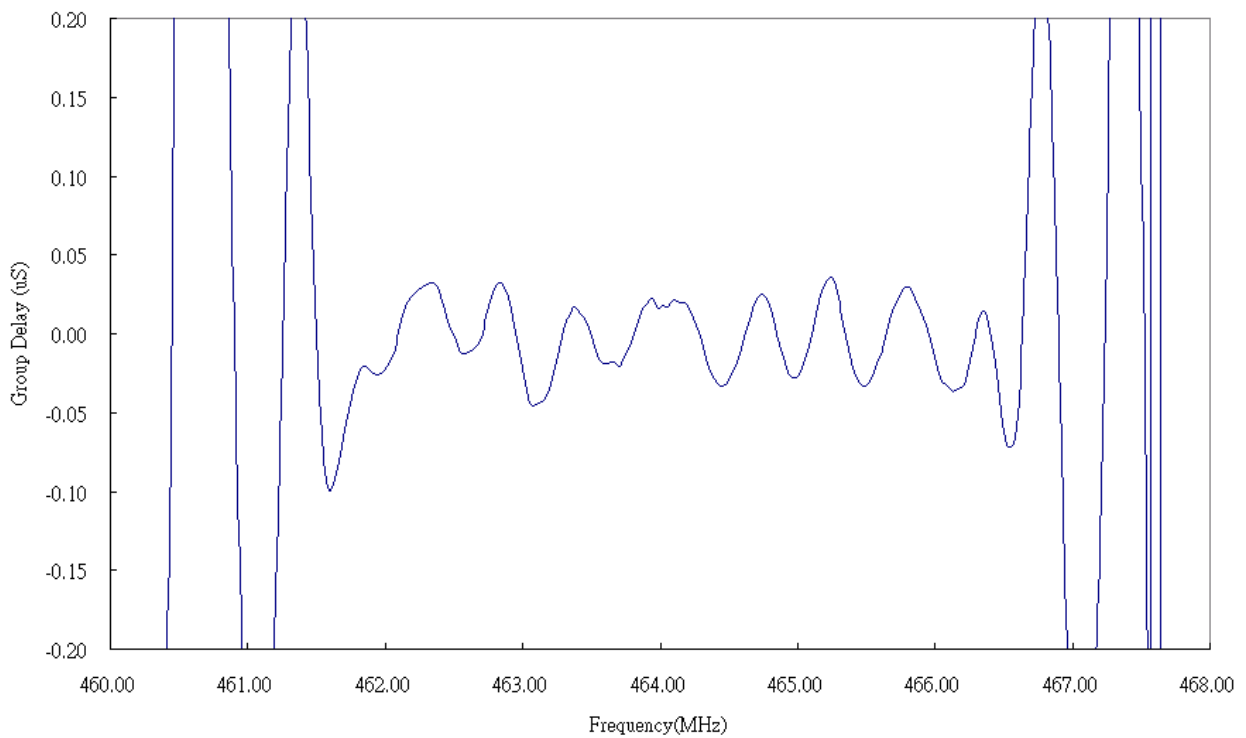

Fig3. Horizontal: 0.8 MHz/Div Vertical: 50nS/Div

(4) Wideband Response

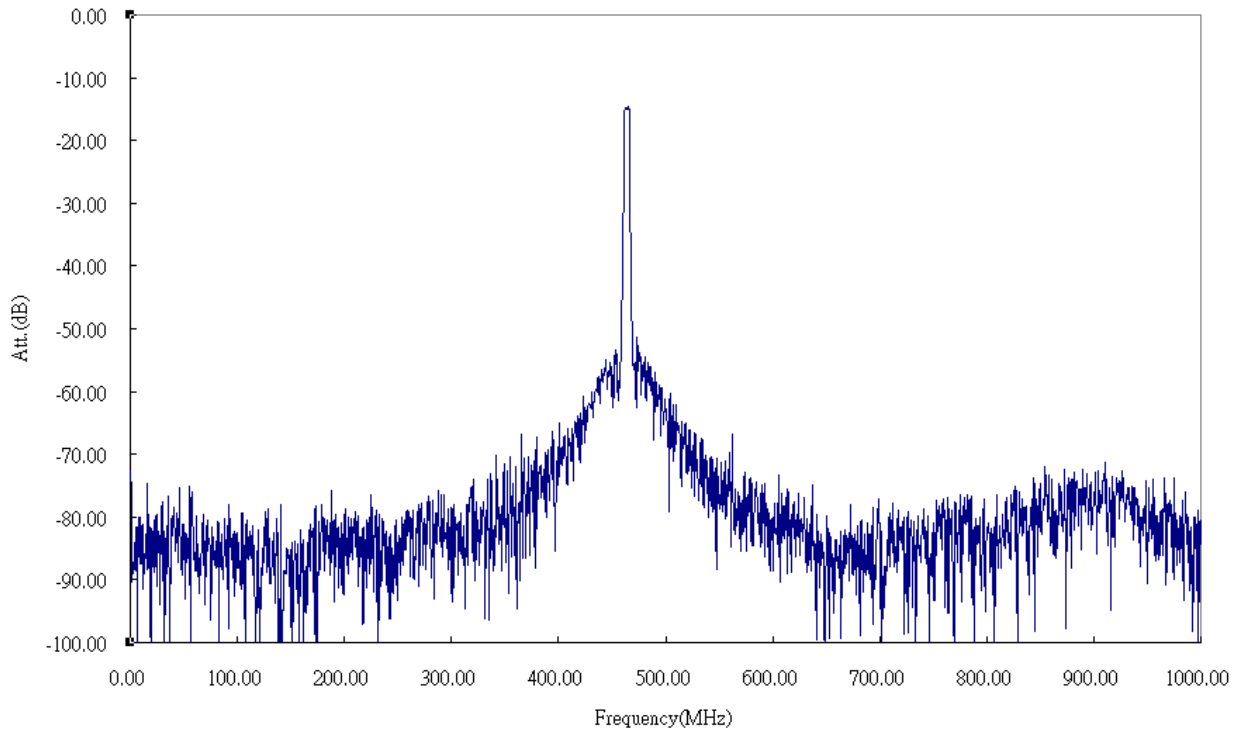
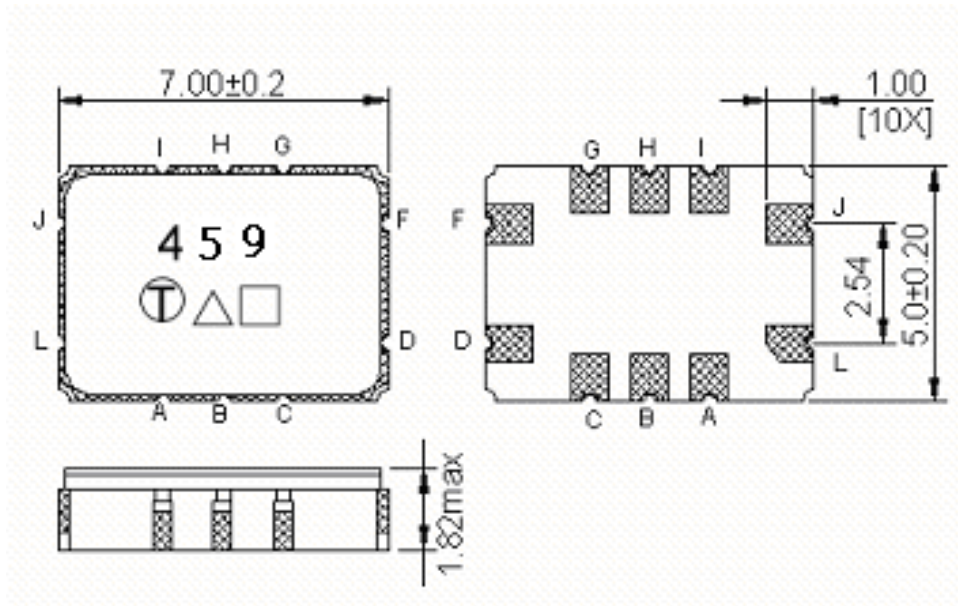

Fig4. Horizontal: 300kHz~1GHz Vertical: 10dB/Div

F. Outline Drawing:



- Pin J,L : Balanced Input
- Pin F,D : Balanced Output
- Pin A,B ,C ,I,H,G : To be Ground

□ : Week Code (Follow the table from planner each year)

Unit : mm

△ : Product / Year Code

Year	2005 2009	2006 2010	2007 2011	2008 2012
Product Code	B	b	<u>B</u>	<u>b</u>

G. PACKING:

1. REEL DIMENSION

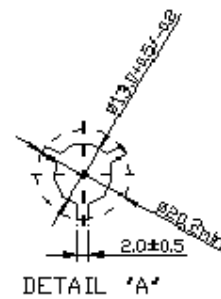
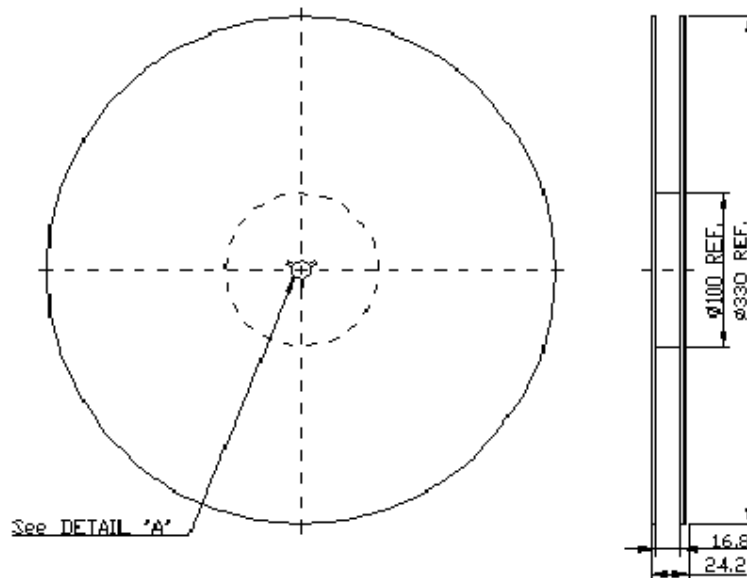

2. TAPE DIMENSION

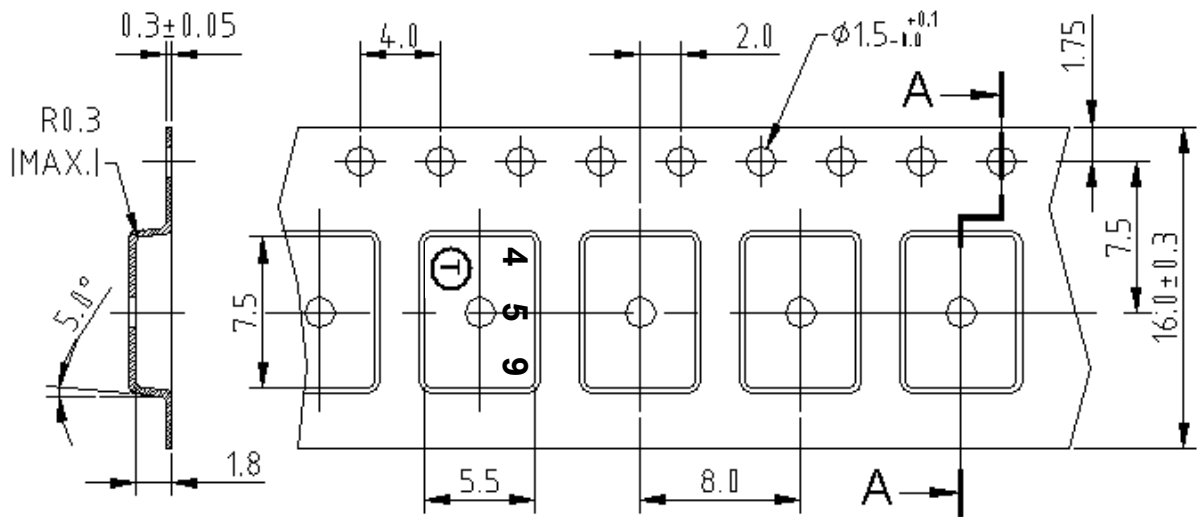

H. RECOMMENDED REFLOW PROFILE_:

