

**Product Specification**

**FCM-8519-1-T4 / FCM-8519-2-T4 Copper GBIC Transceiver**

Finisar’s FCM-8519-1-T4/FCM-8519-2-T4 copper GBIC transceivers comply with GBIC Specification Revision 5.4<sup>1</sup>. They are compatible with the Gigabit Ethernet 1000BASE-CX standard as specified in IEEE Draft P802.3z/D5.0<sup>2</sup> and with Fibre Channel FC-PH3<sup>3</sup>. The modules are available with both DB9 (FCM-8519-1-T4) and HSSDC (FCM-8519-2-T4) connectors.

**I. GBIC to Host Connector Pin Out**

Pin Name	Pin #	Sequence
RX_LOS	1	2
GND	2	2
GND	3	2
MOD_DEF(0)	4	2
MOD_DEF(1)	5	2
MOD_DEF(2)	6	2
TX_DISABLE	7	2
GND	8	2
GND	9	2
TX_FAULT	10	2
GND	11	1
-RX_DAT	12	1
+RX_DAT	13	1
GND	14	1
V <sub>CC</sub>	15	2
V <sub>CC</sub>	16	2
GND	17	1
+TX_DAT	18	1
-TX_DAT	19	1
GND	20	1

**Table 1. GBIC to host connector pin assignment**

“Sequence” indicates the order in which pins make contact when the device is hot plugged.

Also see “Table 3: Signal Definitions” in the GBIC Specification Revision 5.4.<sup>1</sup>

## II. +5 Volt Electrical Power Interface

Finisar GBICs have an extended power supply voltage range of 4.5V to 5.5V as described in Table 2. The GBIC specification calls for a range of 4.75V to 5.25 volts. The 6V maximum voltage is not allowed for continuous operation, however, TX\_DISABLE circuitry in Finisar copper GBICs will function at 6V.

+5 Volt Electrical Power Interface						
Parameter	Symbol	Min	Typ	Max	Units	Notes/Conditions
Supply Current	$I_s$	80		140	mA	
Maximum Voltage	$V_{max}$			6	V	
Surge Current	$I_{surge}$			+30	mA	Hot plug, above steady state current.
Input Voltage	$V_{cc}$	4.5	5	5.5	V	Referenced to GND.

Table 2. +5 volt electrical power interface

## III. Low Speed Signals

Pin Name	Pin #	Description	Pin Name	Pin #	Description
RX_LOS	1	Receiver Loss of Signal CMOS Open Drain Output	RGND	11	GND
RGND	2	GND	-RX_DAT	12	-RX
RGND	3	GND	+RX_DAT	13	+RX
MOD_DEF(0)	4	TTL LOW (Tied to GND)	RGND	14	GND
MOD_DEF(1)	5	SCL CMOS Open Drain Serial Clock	VDDR	15	VCC
MOD_DEF(2)	6	SDA CMOS Open Drain Serial Data	VDDT	16	VCC
TX_DISABLE	7	Transmitter Disable, TTL Input	TGND	17	GND
TGND	8	GND	+TX_DAT	18	+TX
TGND	9	GND	-TX_DAT	19	-TX
TX_FAULT	10	TTL LOW (Tied to GND) - TX_FAULT Not Implemented	TGND	20	GND

Table 3. GBIC pin usage, HSSDC and DB9 copper modules

Low Speed Signals, Electronic Characteristics					
Parameter	Symbol	Min	Max	Units	Notes/Conditions
GBIC Output LOW	$V_{OL}$	0	0.5	V	4.7k to 10k pull-up to host_Vcc, measured at host side of connector
GBIC Output HIGH	$V_{OH}$	host_Vcc - 0.5	host_Vcc + 0.3	V	4.7k to 10k pull-up to host_Vcc, measured at host side of connector
GBIC Input LOW	$V_{IL}$	0	0.8	V	4.7k to 10k pull-up to Vcc, measured at GBIC side of connector
GBIC Input HIGH	$V_{IH}$	2	Vcc + 0.3	V	4.7k to 10k pull-up to Vcc, measured at GBIC side of connector

Table 4. Low speed signals – electronic characteristics

Low Speed Signal Parameters						
Parameter	Symbol	Min	Typ	Max	Units	Notes/Conditions
RX_LOS Assert Level	--		50		mV	
RX_LOS Deassert Level	--		90		mV	
RX_LOS Hysteresis	--		40		mV	
RX_LOS Assert Delay	t_loss_on		10	100	µsec	From detection of loss of signal to assertion of RX_LOS
RX_LOS Negate Delay	t_loss_off		10	100	µsec	From detection of presence of signal to negation of RX_LOS
TX_DISABLE Assert Time	t_off		5	10	µsec	Rising edge of TX_DISABLE to fall of output signal below 10% of nominal
TX_DISABLE Negate Time	t_on		5	1000	µsec	Falling edge of TX_DISABLE to rise of output signal above 90% of nominal
TX Output Amplitude, TX_DISABLE Asserted				70	mV	Peak to peak

Table 5. Low speed signal parameters (preliminary)

TX\_DISABLE is a TTL signal as described in Tables 3 and 4. RX\_LOS is a CMOS open drain output. MOD\_DEF(1) (SCL) and MOD\_DEF(2) (SDA) are open drain CMOS signals (see section VII, “Serial Communication Protocol”). Note that all Finisar copper GBICs are 'module definition 4' since they support the serial identification protocol. MOD\_DEF(1), MOD\_DEF(2), and RX\_LOS must be pulled up to host\_Vcc.

For more detailed information, see sections 5.3.1 – 5.3.8 in the GBIC Specification Rev. 5.4<sup>1</sup>.

**IV. High Speed Electrical Interface**

All high-speed PECL signals to and from the host board are AC coupled internally.

High Speed Electrical Host – GBIC Interface						
Parameter	Symbol	Min	Typ	Max	Units	Notes/Conditions
Data Input Voltage From Host Board to GBIC	$V_{in}$	650		2000	mV	PECL differential peak - peak
Data Output Voltage from GBIC to Host Board	$V_{out}$	370		2000	mV	PECL differential peak - peak
Tx Input Impedance	$Z_{in}$		75		ohm	
Rx Output Impedance	$Z_{out}$		75		ohm	

**Table 6. High-speed electrical interface - host to GBIC connector**

All high speed PECL signals to and from the copper transmission line are AC coupled internally and terminated into 75Ω (150Ω differential).

High Speed GBIC – Transmission Line Interface						
Parameter	Symbol	Min	Typ	Max	Units	Notes/Conditions
Transmit Output Amplitude	$V_{TX, out}$	1100		2000	mV	PECL differential peak - peak
Receive Input Amplitude	$V_{RX, in}$	400		2000	mV	PECL differential peak - peak
Transmitter Total Jitter at Line Output	$J_t$			223	ps	Input to GBIC from host < 192 ps jitter per IEEE802.3
Receiver Total Jitter at GBIC output	$J_r$			568	ps	Input to GBIC from line < 528ps jitter per IEEE802.3
Transmit Rise/Fall Time	$T_{rise/fall}$	85		327	ps	
Tx Output Impedance	$Z_{out, TX}$		75		ohm	
Rx Input Impedance	$Z_{in, RX}$		75		ohm	

**Table 7. High-speed electrical interface – GBIC to line connector**

Pin Name	Pin #
+TX	1
No Connection	2
-TX	3
No Connection	4
No Connection	5
-RX	6
No Connection	7
+RX	8

**Table 8. HSSDC pin assignment**

Pin Name	Pin #
+TX	1
No Connection	2
No Connection	3
No Connection	4
+RX	5
-TX	6
No Connection	7
No Connection	8
-RX	9

**Table 9. DB9 pin assignment**

## V. General Specifications

General						
Parameter	Symbol	Min	Typ	Max	Units	Notes/Conditions
Data Rate	BR	0.1	1.25, 1.0625		Gb/sec	Fibre Channel, IEEE 802.3 Compatible
Cable Length	L			28	m	
Bit Error Rate	BER			$10^{-12}$	error/sec	PRBS $2^7 - 1$ test data pattern through 28m cable
Duty Cycle	--		50		%	

**Table 10. General specifications**

**VI. Environmental Specifications**

Note that the GBIC Specification requires an ambient temperature range of 0 to 50C. Finisar GBICs have an extended range from -10C to +85C case temperature as specified in Table 8.

Environment						
Parameter	Symbol	Min	Typ	Max	Units	Notes/Conditions
Operating Temp	T <sub>op</sub>	-10		85	C	
Storage Temp	T <sub>sto</sub>	-10		85	C	

**Table 11. Environmental Specifications****VII. Serial Communication Protocol**

All Finisar copper GBICs are ‘Module Definition “4”’, and support the 2 wire serial communication protocol outlined in the GBIC Specification <sup>1</sup>. Finisar GBICs use an Atmel AT24C01A 128 byte E<sup>2</sup>PROM (with an address of 1010000X). For details on interfacing with the E<sup>2</sup>PROM, see the Atmel data sheet titled “AT24C01A/02/04/08/16 2-Wire Serial CMOS E<sup>2</sup>PROM.”<sup>5</sup>

I <sup>2</sup> C Timing Requirements						
Parameter	Symbol	Min	Typ	Max	Units	Notes/Conditions
Atmel I <sup>2</sup> C Clock Rate	C <sub>atmel</sub>	0		100,000	Hz	Bus can be driven blind.

**Table 12. I<sup>2</sup>C timing requirements**

**VIII. Mechanical Specifications**

Finisar GBICs conform to the mechanical specifications outlined in the GBIC Specification Revision 5.4, Section 6<sup>1</sup>.

Insertion, Extraction, and Retention Forces						
Parameter	Symbol	Min	Typ	Max	Units	Notes/Conditions
GBIC insertion	F <sub>I</sub>	0		20	Newtons	~4.5 lbs
GBIC extraction	F <sub>E</sub>	0		15	Newtons	~3.3 lbs
GBIC retention	F <sub>R</sub>	130		N/A	Newtons	straight out ~29.3 lbs

**Table 10. Insertion, extraction, and retention forces**

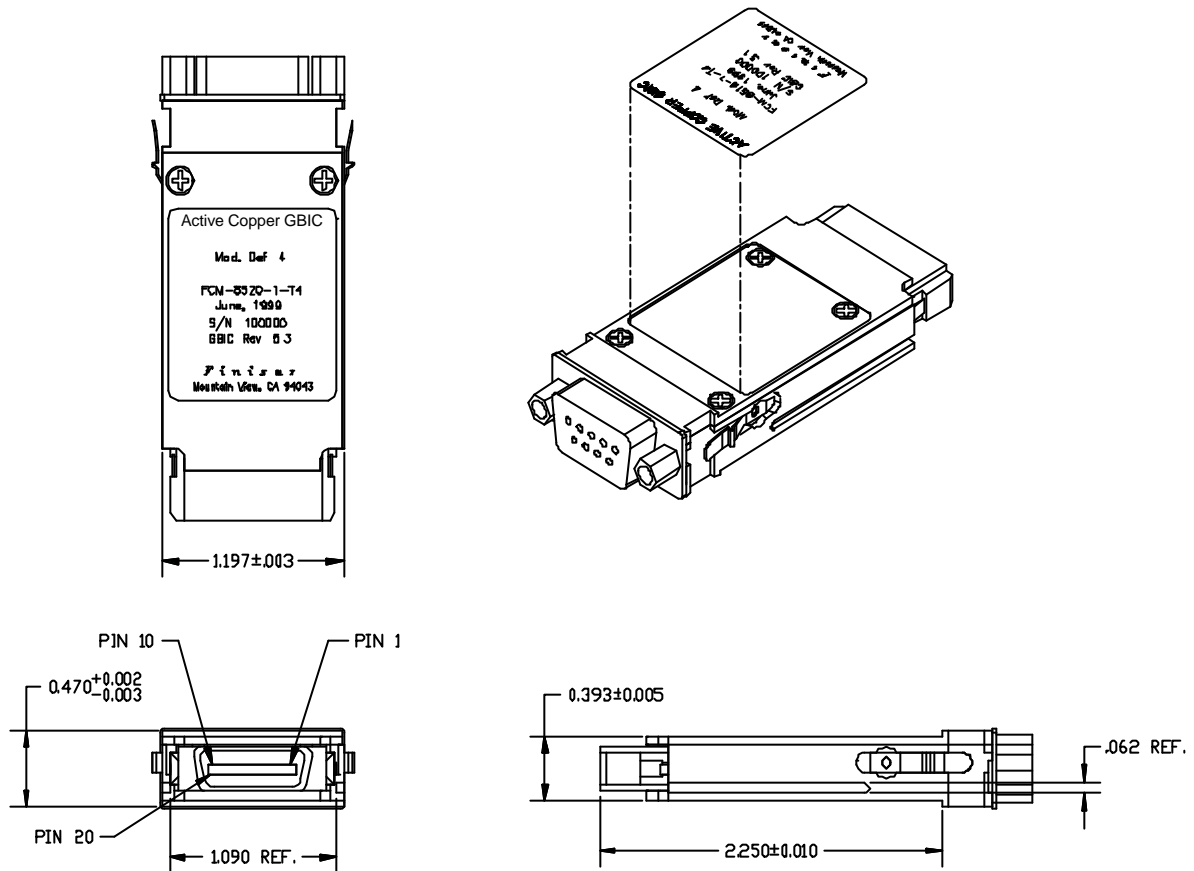

**Figure 1. GBIC Outline Drawing (DB9)**

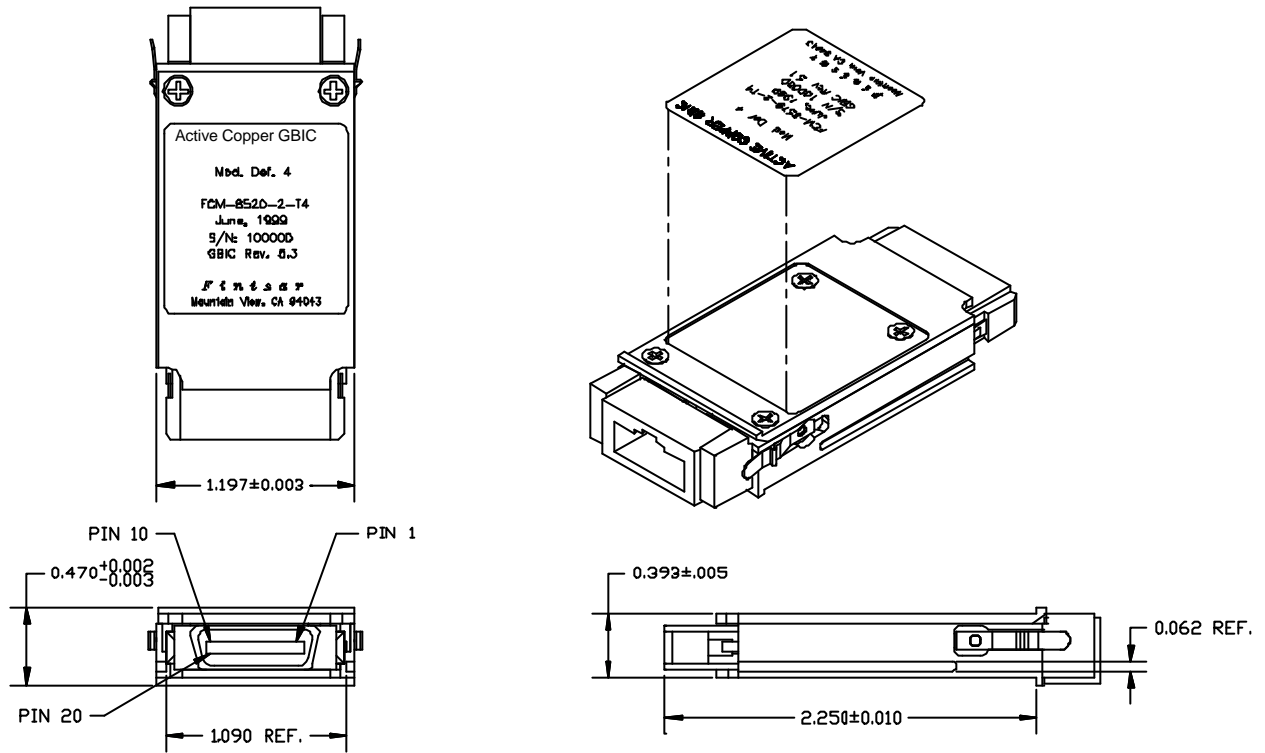

**Figure 2. GBIC Outline Drawing (HSSDC)**



**IX. References**

1. “Gigabit Interface Converter (GBIC) Revision 5.4”. Sun Microsystems Computer Company et. al., August 16, 1999. <http://playground.sun.com/pub/OEmod/>
2. “IEEE Draft P802.3z/D5.0 ‘Media Access Control (MAC) Parameters, Physical Layer, Repeater and Management Parameters for 1000Mb/s Operation’”. IEEE Standards Department, 1998.
3. “Fibre Channel Physical and Signaling Interface (FC-PH, FC-PH2, FC-PH3)”. American National Standard for Information Systems.
4. “AT24C01A/02/04/08/16 2-Wire Serial CMOS E<sup>2</sup>PROM”. Atmel Corporation. [www.Atmel.com](http://www.Atmel.com)