

DATA SHEET

SAA7157

Clock signal generator circuit for
digital TV systems (SCGC)

Product specification
File under Integrated Circuits, IC02

May 1992

Clock signal generator circuit for digital TV systems (SCGC)

SAA7157

FEATURES

- Clock generation suitable for digital TV systems (line-locked)
- PLL frequency multiplier to generate 4 times of input frequency
- Dividers to generate clocks LL1.5A, LL1.5B, LL3A and LL3B (4th and 2nd multiples of input frequency)
- PLL mode or VCO mode selectable
- Reset control and power fail detection
- Suitable for applications with feature box and picture memory

GENERAL DESCRIPTION

The SAA7157 generates all clock signals required for a digital TV system suitable for the SAA715x family and the SAA7199B (DENC). The circuit operates in either the phase-locked loop mode (PLL) or voltage controlled oscillator mode (VCO).

QUICK REFERENCE DATA

SYMBOL	PARAMETER	MIN.	TYP.	MAX.	UNIT
V_{DDA}	analog supply voltage (pin 5)	4.5	5.0	5.5	V
V_{DDD}	digital supply voltage (pins 8, 17)	4.5	5.0	5.5	V
I_{DDA}	analog supply current	3	-	9	mA
I_{DDD}	digital supply current	10	-	60	mA
V_{LFCO}	LFCO input voltage (peak-to-peak value)	1	-	V_{DDA}	V
f_i	input frequency range	6.0	-	7.25	MHz
V_i	input voltage LOW input voltage HIGH	0 2.0	- -	0.8 V_{DDD}	V V
V_o	output voltage LOW output voltage HIGH	0 2.6	- -	0.6 V_{DDD}	V V
T_{amb}	operating ambient temperature range	0	-	70	°C

ORDERING INFORMATION

EXTENDED TYPE NUMBER	PACKAGE			
	PINS	PIN POSITION	MATERIAL	CODE
SAA7157	20	DIL	plastic	SOT146 ⁽¹⁾
SAA7157T	20	mini-pack (SO20)	plastic	SOT163A ⁽²⁾

Note

1. SOT146-1; 1996 December 17.
2. SOT163-1; 1996 December 17.

Clock signal generator circuit for digital TV systems (SCGC)

SAA7157

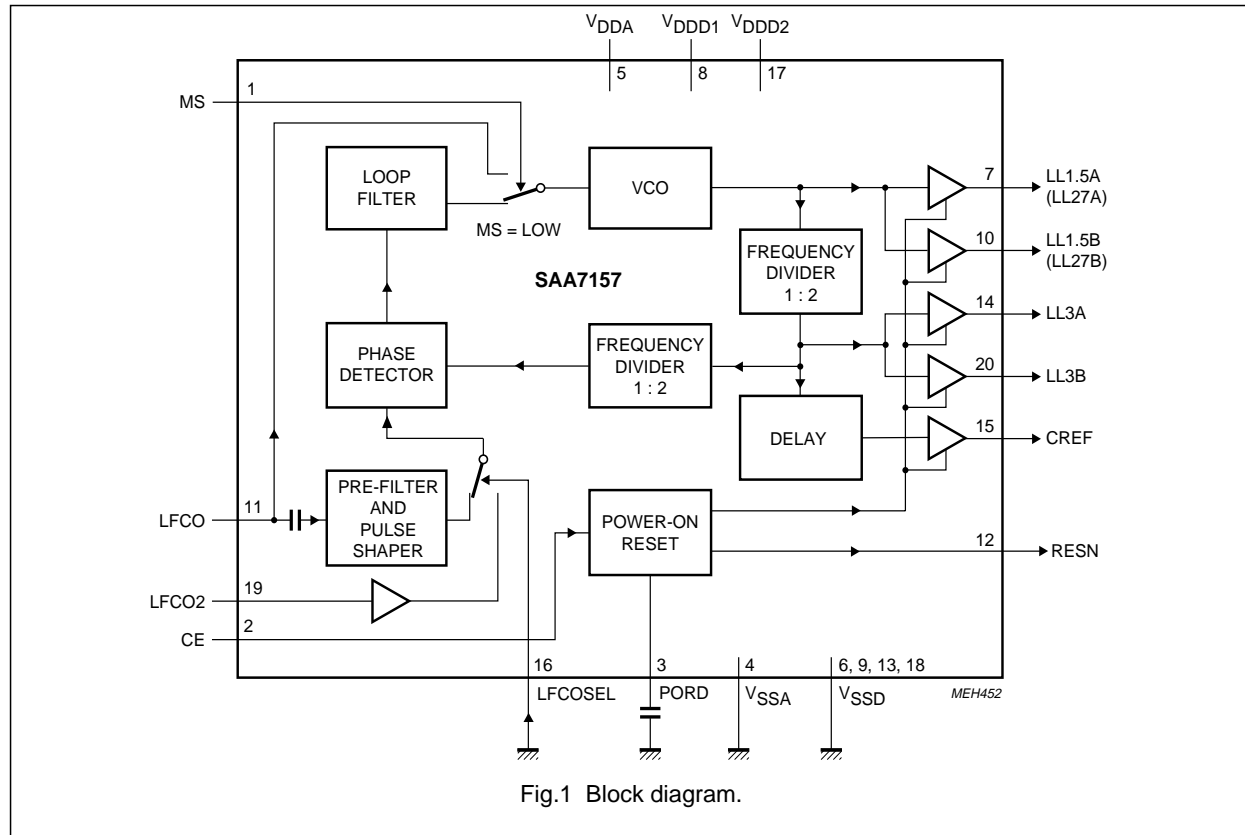

FUNCTIONAL DESCRIPTION

The SAA7157 generates all clock signals required for a digital TV system suitable for the SAA715x family consisting of an 8-bit analog-to-digital converter (ADC8), digital video multistandard decoder (DMSD2) and video enhancement and D/A processor circuit (VEDA). Optional extras (feature box, video memory etc.) can be driven via external buffers, advantageous for a digital TV system based on display standard conversion concepts.

The 6.75 MHz input signal LFCO (triangular waveform) coming from the DMSD or LFCO2 is multiplied to 27 MHz by the PLL (including phase detector, loop filter, VCO and frequency divider) and output on LL1.5A (pin 7) and LL1.5B (pin 10). The 13.5 MHz frequencies are generated by dividers using ratio of 1:2 and are output on LL3A (pin 14) and LL3B (pin 20).

The rectangular output signals have 50% duty factor. Outputs with equal frequency may be connected together externally. The clock outputs go HIGH during power-on reset (and chip enable) to ensure that no output clock signals are available before the PLL has locked-on.

Mode select MS

The LFCO input signal is directly connected to the VCO at MS = HIGH. The circuit operates as an oscillator and frequency divider. This function is not tested.

Source select LFCOSEL

Line frequency control signal (LFCO) is selected by LFCOSEL input.

LFCOSEL = LOW:

signal from LFCO (pin 11) is selected.

LFCOSEL = HIGH:

signal from LFCO2 (pin 19) is selected.

This function is not tested.

Chip enable CE

The buffer outputs are enabled and RESN is set to HIGH by CE = HIGH (Fig.4).

CE = LOW sets the clock outputs HIGH and RESN output LOW.

Clock signal generator circuit for digital TV systems (SCGC)

SAA7157

CREF output

TV2 digital clock reference output signal. Clock qualifier signal to TV system with 2 times of LFCO or LFCO2 frequency.

Power-on reset

Power-on reset is activated at power-on, when the supply voltage decreases below 3.5 V (Fig.4) or when chip enable is done. The indicator output RESN is LOW for a time determined by capacitor on pin 3. The RESN signal can be applied to reset other circuits of this digital TV system.

The LFCO or LFCO2 input signals have to be applied before RESN becomes HIGH.

PINNING

SYMBOL	PIN	DESCRIPTION
MS	1	mode select input (LOW = PLL mode)
CE	2	chip enable /reset (HIGH = outputs enabled)
PORD	3	power-on reset delay, dependent on external capacitor
V _{SSA}	4	analog ground (0 V)
V _{DDA}	5	analog supply voltage (+5 V)
V _{SSD1}	6	digital ground 1 (0 V)
LL1.5A	7	line-locked clock output signal 1.5A (4 times f_{LFCO})
V _{DDD1}	8	digital supply voltage 1 (+5 V)
V _{SSD2}	9	digital ground 2 (0 V)
LL1.5B	10	line-locked clock output signal 1.5B (4 times f_{LFCO})
LFCO	11	line-locked frequency control input signal 1
RESN	12	reset output (active-LOW, Fig.4)
V _{SSD3}	13	digital ground 3 (0 V)
LL3A	14	line-locked clock output signal 3A (2 times f_{LFCO})
CREF	15	clock reference output, qualifier signal (2 times f_{LFCO})
LFCOSEL	16	LFCO source select (LOW = LFCO selected) ⁽¹⁾
V _{DDD2}	17	digital supply voltage 2 (+5 V)
V _{SSD4}	18	digital ground 4 (0 V)
LFCO2	19	line-locked frequency control input signal 2 ⁽¹⁾
LL3B	20	line-locked clock output signal 3B (2 times f_{LFCO})

Note

- MS and LFCO2 functions are not tested. LFCO2 is a multiple of horizontal frequency.

Clock signal generator circuit for digital TV systems (SCGC)

SAA7157

PIN CONFIGURATION

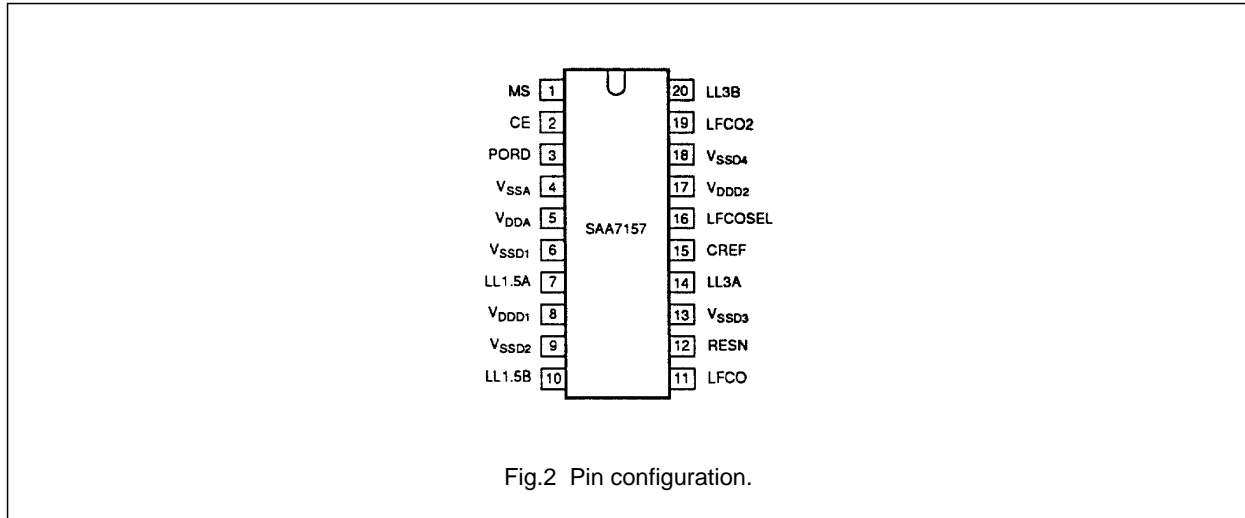

LIMITING VALUES

In accordance with the Absolute Maximum Rating System (IEC 134); ground pins as well as supply pins together connected.

SYMBOL	PARAMETER	MIN.	MAX.	UNIT
V_{DDA}	analog supply voltage (pin 5)	-0.5	7.0	V
V_{DDD}	digital supply voltage (pins 8 and 17)	-0.5	7.0	V
$V_{diff\ GND}$	difference voltage $V_{DDA} - V_{DDD}$	-	± 100	mV
V_O	output voltage ($I_{OM} = 20\text{ mA}$)	-0.5	V_{DDD}	V
P_{tot}	total power dissipation (DIL20)	0	1.1	W
T_{stg}	storage temperature range	-65	150	$^{\circ}\text{C}$
T_{amb}	operating ambient temperature range	0	70	$^{\circ}\text{C}$
V_{ESD}	electrostatic handling ⁽¹⁾ for all pins	-	tbf	V

Notes

- Inputs and outputs are protected against electrostatic discharge in normal handling. However, to be totally safe, it is recommended to take normal handling precautions appropriate to "Handling MOS devices".

Clock signal generator circuit for digital TV systems (SCGC)

SAA7157

CHARACTERISTICS

$V_{DDA} = 4.5$ to 5.5 V; $V_{DDD} = 4.5$ to 5.5 V; $f_{LFCO} = 6.0$ to 7.25 MHz and $T_{amb} = 0$ to 70 °C unless otherwise specified.

SYMBOL	PARAMETER	CONDITIONS	MIN.	TYP.	MAX.	UNIT
V_{DDA}	analog supply voltage (pin 5)		4.5	5.0	5.5	V
V_{DDD}	digital supply voltage (pins 8 and 17)		4.5	5.0	5.5	V
I_{DDA}	analog supply current (pin 5)		3	–	9	mA
I_{DDD}	digital supply current ($I_8 + I_{17}$)	note 1	10	–	60	mA
V_{reset}	power-on reset threshold voltage	Fig.4	–	3.5	–	V
Input LFCO (pin 11)						
V_{11}	DC input voltage		0	–	V_{DDA}	V
V_i	input signal (peak-to-peak value)		1	–	V_{DDA}	V
f_{LFCO}	input frequency range		6.0	–	7.25	MHz
C_{11}	input capacitance		–	–	10	pF
Inputs MS, CE, LFCOSEL and LFCO2 (pins 1, 2, 16 and 19); note 3						
V_{IL}	input voltage LOW		0	–	0.8	V
V_{IH}	input voltage HIGH		2.0	–	V_{DDD}	V
f_{LFCO2}	input frequency range for LFCO2		6.0	–	7.25	MHz
I_{LI}	input leakage current	LFCOSEL others	50 –	– –	150 10	μ A μ A
C_i	input capacitance		–	–	5	pF
Output RESN (pin 12)						
V_{OL}	output voltage LOW	$I_{OL} = 2$ mA	0	–	0.4	V
V_{OH}	output voltage HIGH	$I_{OH} = -0.5$ mA	2.4	–	V_{DDD}	V
t_d	RESN delay time	$C_3 = 0.1$ μ F; Fig.4	20	–	200	ms
Output CREF (pin 15)						
V_{OL}	output voltage LOW	$I_{OL} = 2$ mA	0	–	0.6	V
V_{OH}	output voltage HIGH	$I_{OH} = -0.5$ mA	2.4	–	V_{DDD}	V
f_{CREF}	output frequency CREF	Fig.3	–	$2 f_{LFCO(2)}$	–	MHz
C_L	output load capacitance		15	–	40	pF
t_{SU}	set-up time	Fig.3; note 1	12	–	–	ns
t_{HD}	hold time	Fig.3; note 1	4	–	–	ns

Clock signal generator circuit for digital TV systems (SCGC)

SAA7157

SYMBOL	PARAMETER	CONDITIONS	MIN.	TYP.	MAX.	UNIT
Output signals LL1.5A, LL1.5B, LL3A and LL3B (pins 7, 10, 14, and 20); note 3						
V_{OL}	output voltage LOW	$I_{OL} = 2 \text{ mA}$	0	-	0.6	V
V_{OH}	output voltage HIGH	$I_{OH} = -0.5 \text{ mA}$	2.6	-	V_{DD}	V
t_{comp}	composite rise time	Fig.3; notes 1 and 2	-	-	8	ns
f_{LL}	output frequency LL1.5A	Fig.3	-	$4 f_{LFCO(2)}$		MHz
	output frequency LL1.5B		-	$4 f_{LFCO(2)}$		MHz
	output frequency LL3A		-	$2 f_{LFCO(2)}$		MHz
	output frequency LL3B		-	$2 f_{LFCO(2)}$		MHz
t_r, t_f	rise and fall times	note 1; Fig.3	-	-	5	ns
t_{LL}	duty factor LL1.5A, LL1.5B, LL3A and LL3B (mean values)	note 1; Fig.3; at 1.5 V level	43	50	57	%

Notes

- $f_{LFCO} = 7.0 \text{ MHz}$ and output load 40 pF (Fig.3). V_{SSA} and V_{SSD} short connected together.
- t_{comp} is the rise time from LOW of all clocks to HIGH of all clocks (Fig.3) including rise time, skew and jitter components. Measurements taken between 0.6 V and 2.6 V. Skew between two LLx clocks will not deviate more than $\pm 2 \text{ ns}$ if output loads are matched within 20%.
- MS and LFCO2 functions not tested.

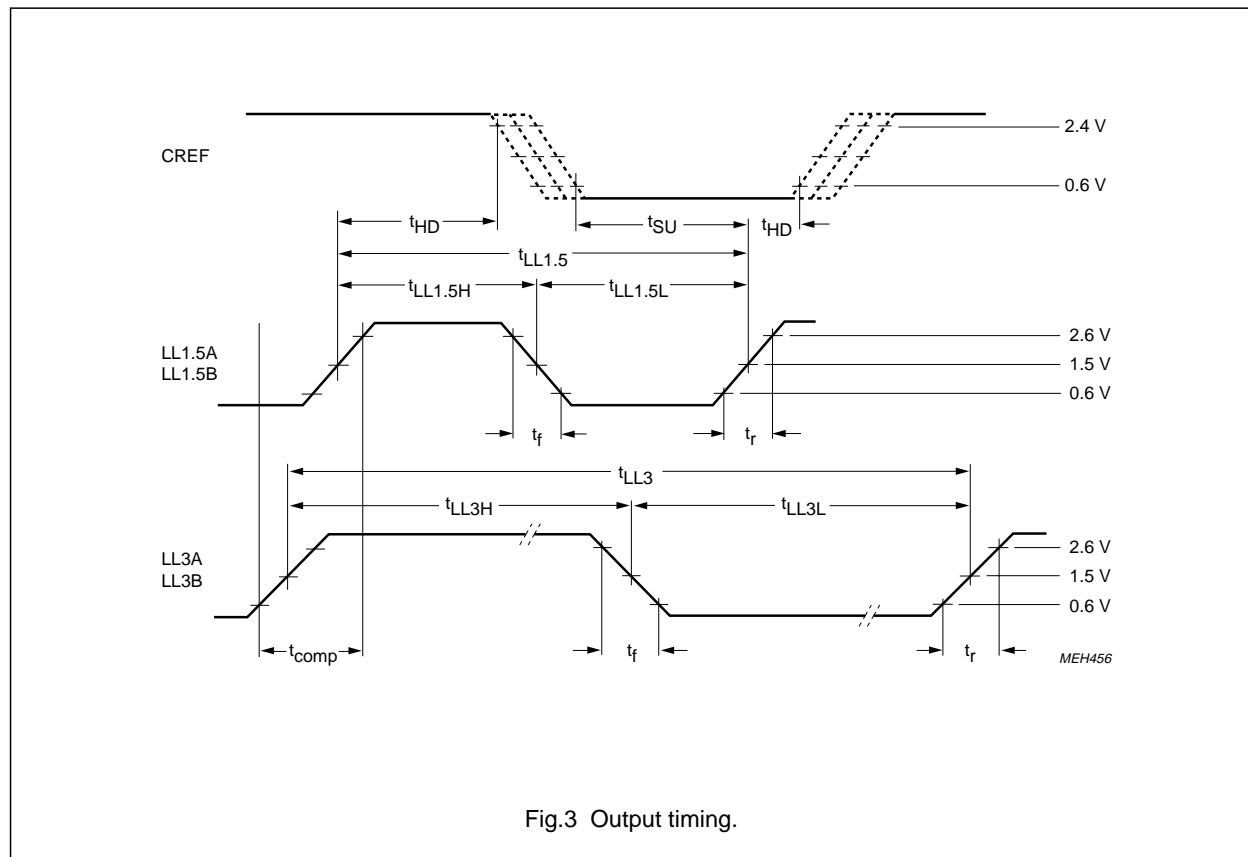

Fig.3 Output timing.

Clock signal generator circuit for digital TV systems (SCGC)

SAA7157

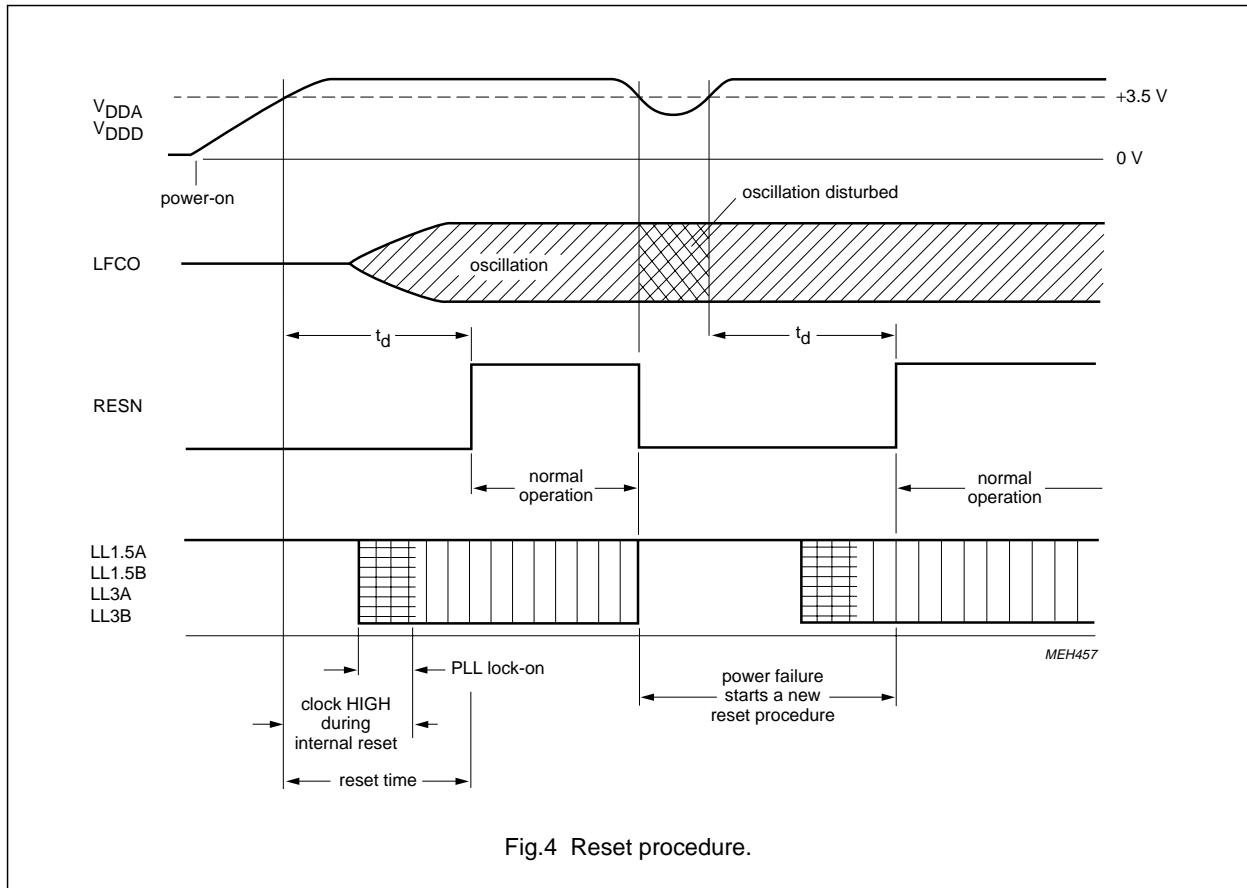

Fig.4 Reset procedure.

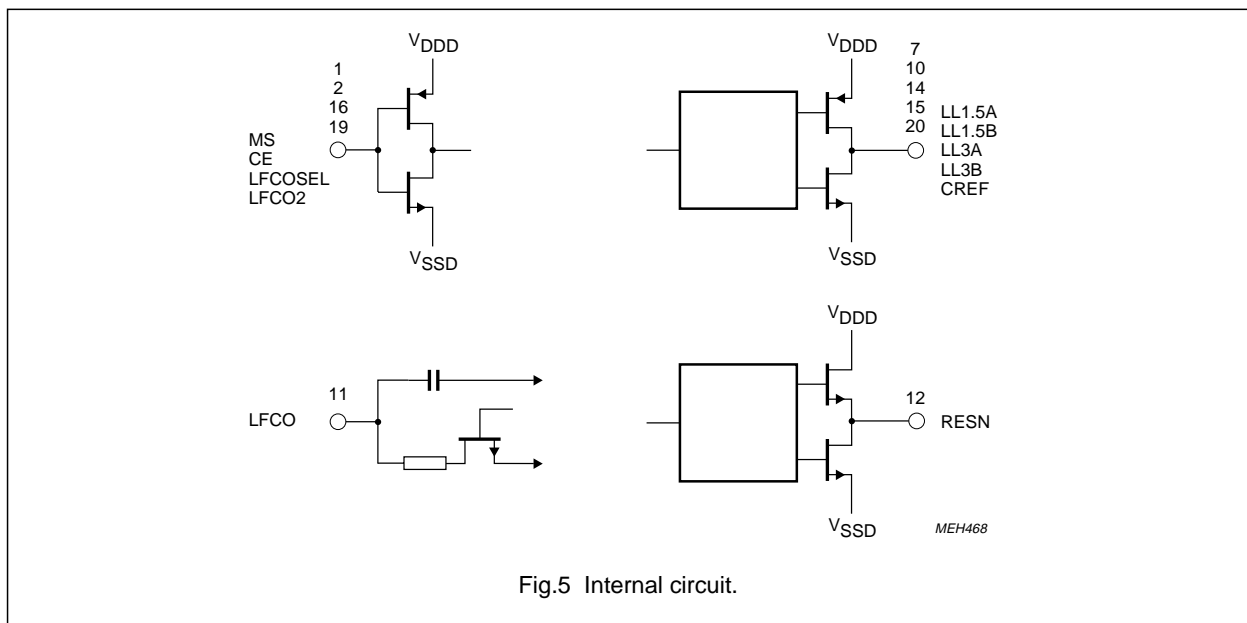

Fig.5 Internal circuit.

Clock signal generator circuit for digital TV systems (SCGC)

SAA7157

PACKAGE OUTLINE

DIP20: plastic dual in-line package; 20 leads (300 mil)

SOT146-1

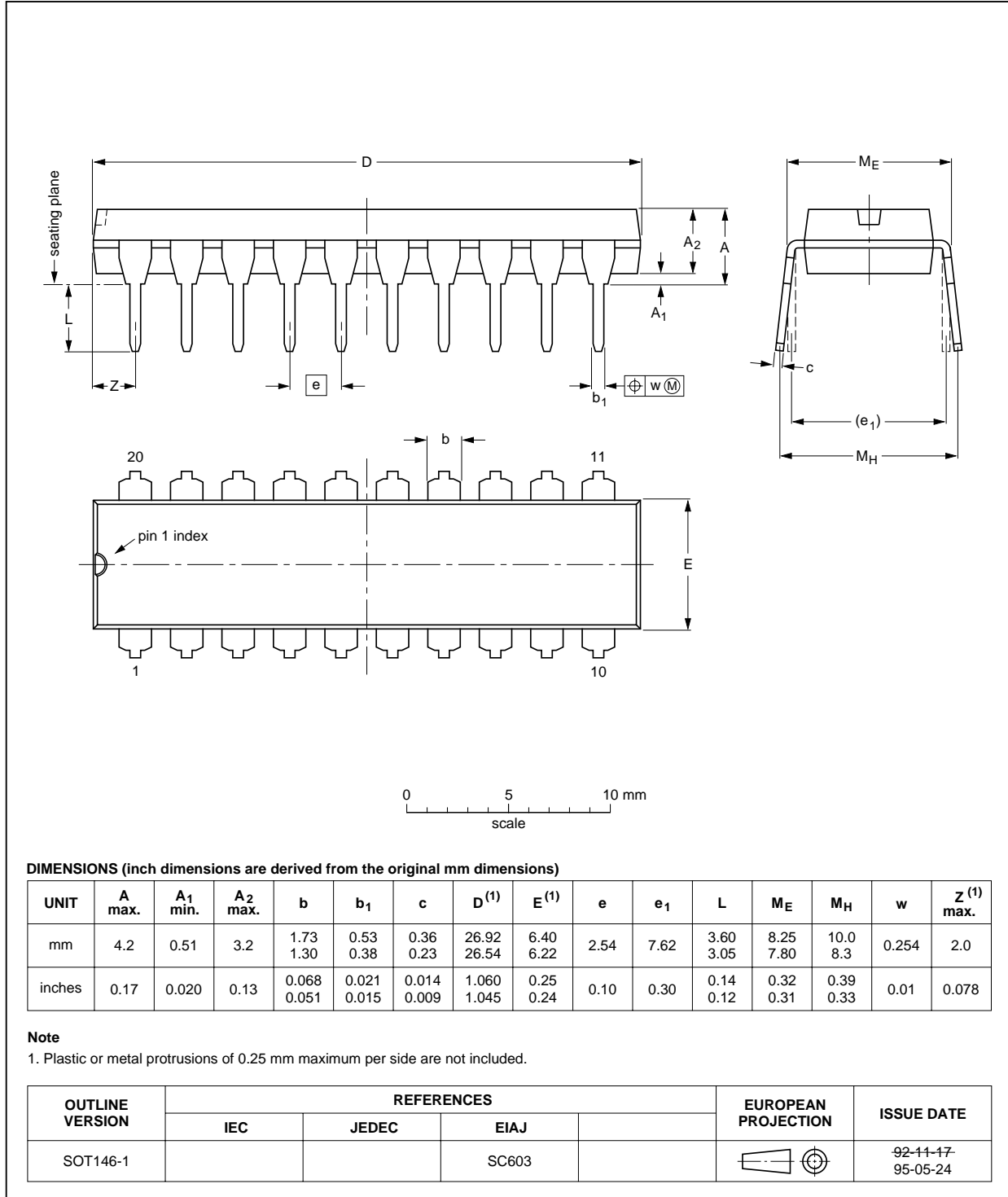

Clock signal generator circuit for digital TV systems (SCGC)

SAA7157

SO20: plastic small outline package; 20 leads; body width 7.5 mm

SOT163-1

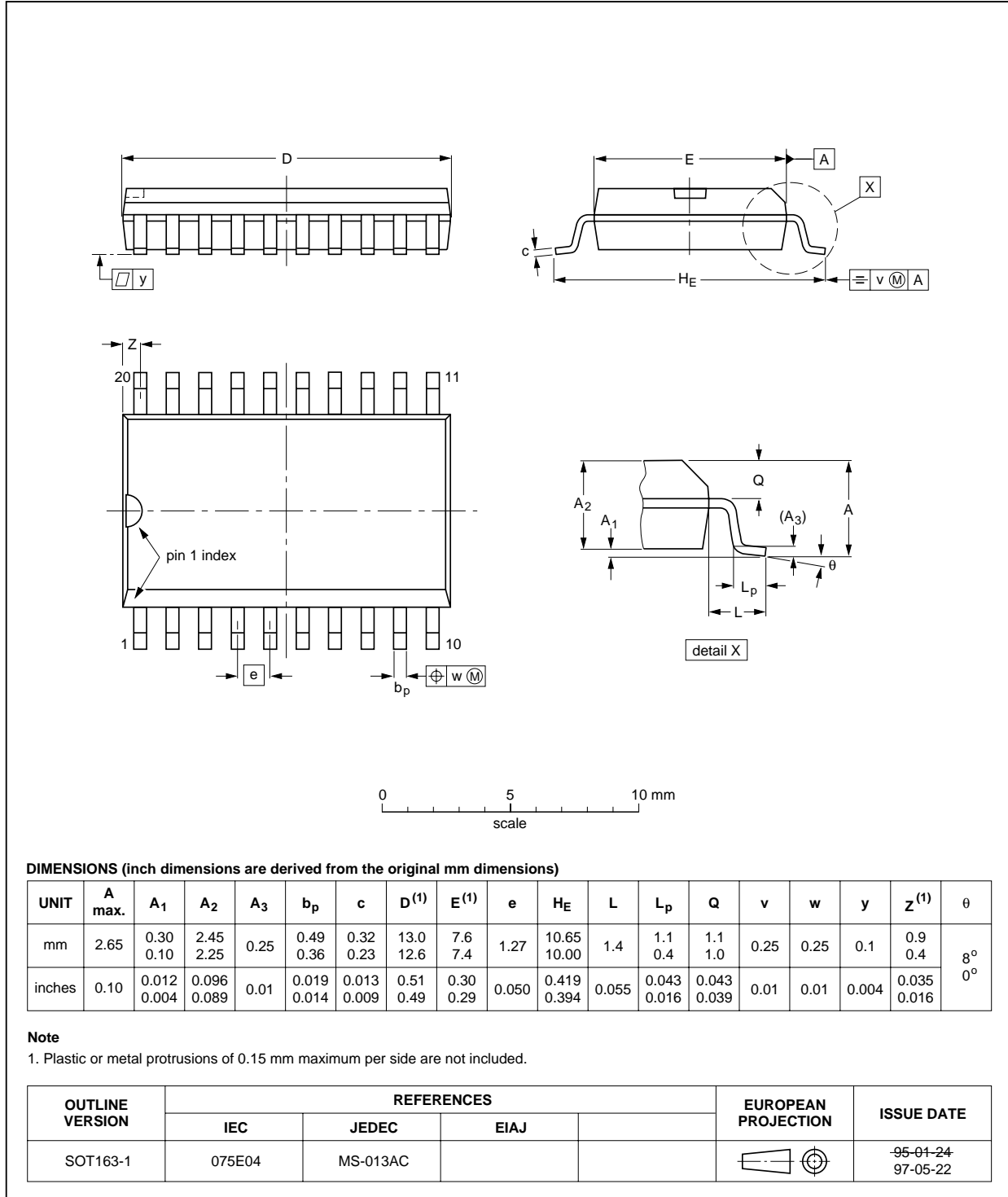

Clock signal generator circuit for digital TV systems (SCGC)

SAA7157

SOLDERING

Introduction

There is no soldering method that is ideal for all IC packages. Wave soldering is often preferred when through-hole and surface mounted components are mixed on one printed-circuit board. However, wave soldering is not always suitable for surface mounted ICs, or for printed-circuits with high population densities. In these situations reflow soldering is often used.

This text gives a very brief insight to a complex technology. A more in-depth account of soldering ICs can be found in our *"IC Package Databook"* (order code 9398 652 90011).

DIP

SOLDERING BY DIPPING OR BY WAVE

The maximum permissible temperature of the solder is 260 °C; solder at this temperature must not be in contact with the joint for more than 5 seconds. The total contact time of successive solder waves must not exceed 5 seconds.

The device may be mounted up to the seating plane, but the temperature of the plastic body must not exceed the specified maximum storage temperature ($T_{stg\ max}$). If the printed-circuit board has been pre-heated, forced cooling may be necessary immediately after soldering to keep the temperature within the permissible limit.

REPAIRING SOLDERED JOINTS

Apply a low voltage soldering iron (less than 24 V) to the lead(s) of the package, below the seating plane or not more than 2 mm above it. If the temperature of the soldering iron bit is less than 300 °C it may remain in contact for up to 10 seconds. If the bit temperature is between 300 and 400 °C, contact may be up to 5 seconds.

SO

REFLOW SOLDERING

Reflow soldering techniques are suitable for all SO packages.

Reflow soldering requires solder paste (a suspension of fine solder particles, flux and binding agent) to be applied to the printed-circuit board by screen printing, stencilling or pressure-syringe dispensing before package placement.

Several techniques exist for reflowing; for example, thermal conduction by heated belt. Dwell times vary between 50 and 300 seconds depending on heating

method. Typical reflow temperatures range from 215 to 250 °C.

Preheating is necessary to dry the paste and evaporate the binding agent. Preheating duration: 45 minutes at 45 °C.

WAVE SOLDERING

Wave soldering techniques can be used for all SO packages if the following conditions are observed:

- A double-wave (a turbulent wave with high upward pressure followed by a smooth laminar wave) soldering technique should be used.
- The longitudinal axis of the package footprint must be parallel to the solder flow.
- The package footprint must incorporate solder thieves at the downstream end.

During placement and before soldering, the package must be fixed with a droplet of adhesive. The adhesive can be applied by screen printing, pin transfer or syringe dispensing. The package can be soldered after the adhesive is cured.

Maximum permissible solder temperature is 260 °C, and maximum duration of package immersion in solder is 10 seconds, if cooled to less than 150 °C within 6 seconds. Typical dwell time is 4 seconds at 250 °C.

A mildly-activated flux will eliminate the need for removal of corrosive residues in most applications.

REPAIRING SOLDERED JOINTS

Fix the component by first soldering two diagonally-opposite end leads. Use only a low voltage soldering iron (less than 24 V) applied to the flat part of the lead. Contact time must be limited to 10 seconds at up to 300 °C. When using a dedicated tool, all other leads can be soldered in one operation within 2 to 5 seconds between 270 and 320 °C.

Clock signal generator circuit for digital TV systems (SCGC)

SAA7157

DEFINITIONS

Data sheet status	
Objective specification	This data sheet contains target or goal specifications for product development.
Preliminary specification	This data sheet contains preliminary data; supplementary data may be published later.
Product specification	This data sheet contains final product specifications.
Limiting values	
Limiting values given are in accordance with the Absolute Maximum Rating System (IEC 134). Stress above one or more of the limiting values may cause permanent damage to the device. These are stress ratings only and operation of the device at these or at any other conditions above those given in the Characteristics sections of the specification is not implied. Exposure to limiting values for extended periods may affect device reliability.	
Application information	
Where application information is given, it is advisory and does not form part of the specification.	

LIFE SUPPORT APPLICATIONS

These products are not designed for use in life support appliances, devices, or systems where malfunction of these products can reasonably be expected to result in personal injury. Philips customers using or selling these products for use in such applications do so at their own risk and agree to fully indemnify Philips for any damages resulting from such improper use or sale.