



Single Supply / Low Power / 256-tap / 2-Wire bus

X9269

Dual Digitally-Controlled (XDCCP™) Potentiometers

FEATURES

- Dual—Two separate potentiometers
- 256 resistor taps/pot—0.4% resolution
- 2-Wire Serial Interface for write, read, and transfer operations of the potentiometer single supply device
- Wiper Resistance, 100Ω typical $V_{CC} = 5V$
- 4 Nonvolatile Data Registers for Each Potentiometer
- Nonvolatile Storage of Multiple Wiper Positions
- Power On Recall. Loads Saved Wiper Position on Power Up.
- Standby Current < 5μA Max
- 50KΩ, 100KΩ versions of End to End Pot Resistance
- 100 yr. Data Retention
- Endurance: 100,000 Data Changes per Bit per Register
- 24-Lead SOIC, 16-Lead CSP (Chip Scale Package), 24-Lead TSSOP
- Low Power CMOS
- Power Supply $V_{CC} = 2.7V$ to 5.5V

DESCRIPTION

The X9269 integrates 2 digitally controlled potentiometer (XDCCP) on a monolithic CMOS integrated circuit.

The digital controlled potentiometer is implemented using 255 resistive elements in a series array. Between each element are tap points connected to the wiper terminal through switches. The position of the wiper on the array is controlled by the user through the 2-Wire bus interface. Each potentiometer has associated with it a volatile Wiper Counter Register (WCR) and a four nonvolatile Data Registers that can be directly written to and read by the user. The contents of the WCR controls the position of the wiper on the resistor array through the switches. Powerup recalls the contents of the default Data Register (DR0) to the WCR.

The XDCCP can be used as a three-terminal potentiometer or as a two terminal variable resistor in a wide variety of applications including control, parameter adjustments, and signal processing.

FUNCTIONAL DIAGRAM

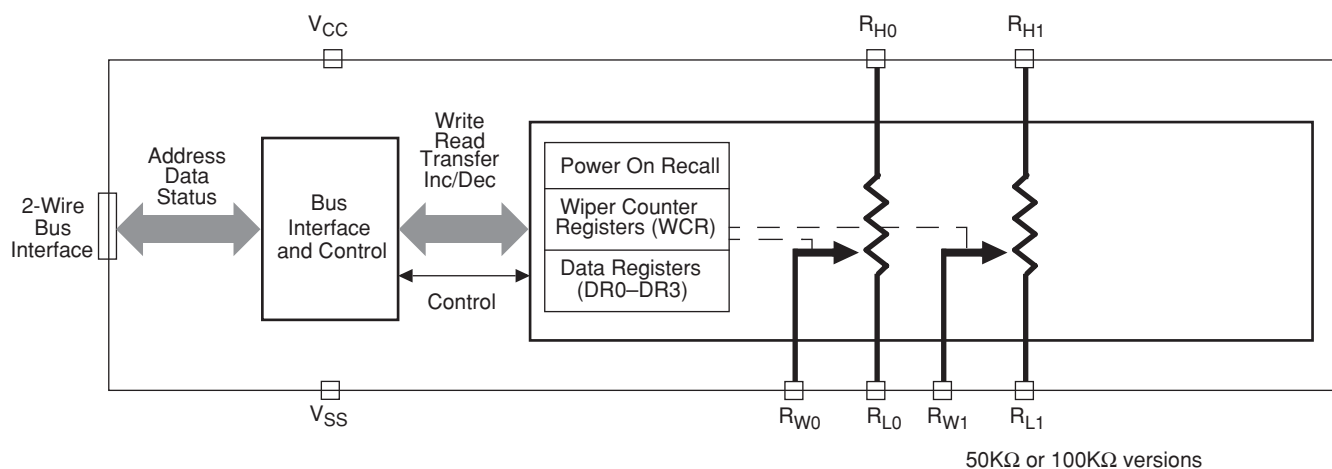

DETAILED FUNCTIONAL DIAGRAM

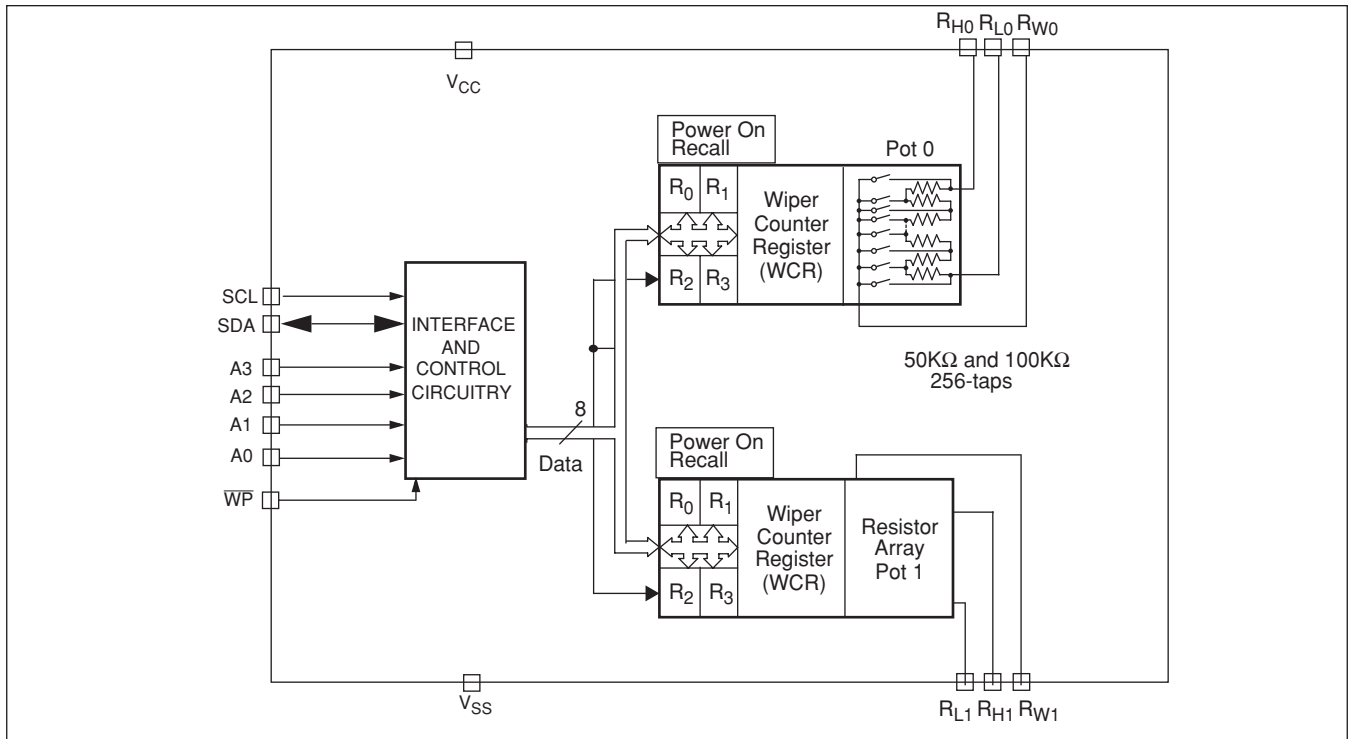

CIRCUIT LEVEL APPLICATIONS

- Vary the gain of a voltage amplifier
- Provide programmable dc reference voltages for comparators and detectors
- Control the volume in audio circuits
- Trim out the offset voltage error in a voltage amplifier circuit
- Set the output voltage of a voltage regulator
- Trim the resistance in Wheatstone bridge circuits
- Control the gain, characteristic frequency and Q-factor in filter circuits
- Set the scale factor and zero point in sensor signal conditioning circuits
- Vary the frequency and duty cycle of timer ICs
- Vary the dc biasing of a pin diode attenuator in RF circuits
- Provide a control variable (I, V, or R) in feedback circuits

SYSTEM LEVEL APPLICATIONS

- Adjust the contrast in LCD displays
- Control the power level of LED transmitters in communication systems
- Set and regulate the DC biasing point in an RF power amplifier in wireless systems
- Control the gain in audio and home entertainment systems
- Provide the variable DC bias for tuners in RF wireless systems
- Set the operating points in temperature control systems
- Control the operating point for sensors in industrial systems
- Trim offset and gain errors in artificial intelligent systems

X9269

PIN CONFIGURATION

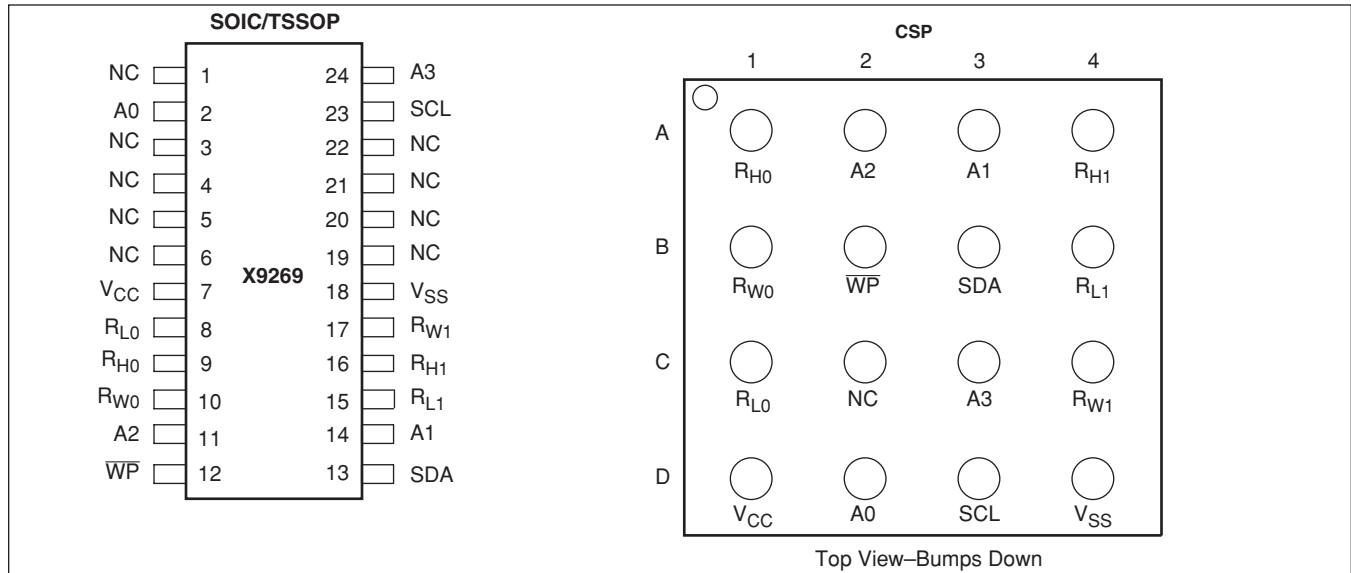

PIN ASSIGNMENTS

Pin (SOIC/TSSOP)	Pin (CSP)	Symbol	Function
1	C2	NC	No Connect
2	D2	A0	Device Address for 2-Wire bus.
3	N/A	NC	No Connect
4	N/A	NC	No Connect
5	N/A	NC	No Connect
6	N/A	NC	No Connect
7	D1	V _{CC}	System Supply Voltage
8	C1	R _{L0}	Low Terminal for Potentiometer 0.
9	A1	R _{H0}	High Terminal for Potentiometer 0.
10	B1	R _{W0}	Wiper Terminal for Potentiometer 0.
11	A2	A2	Device Address for 2-Wire bus.
12	B2	W _P	Hardware Write Protect
13	B3	SDA	Serial Data Input/Output for 2-Wire bus.
14	A3	A1	Device Address for 2-Wire bus.
15	B4	R _{L1}	Low Terminal for Potentiometer 1.
16	A4	R _{H1}	High Terminal for Potentiometer 1.
17	C4	R _{W1}	Wiper Terminal for Potentiometer 1.
18	D4	V _{SS}	System Ground
19	N/A	NC	No Connect
20	N/A	NC	No Connect
21	N/A	NC	No Connect
22	N/A	NC	No Connect
23	D3	SCL	Serial Clock for 2-Wire bus.
24	C3	A3	Device Address for 2-Wire bus.

PIN DESCRIPTIONS

Bus Interface Pins

SERIAL DATA INPUT/OUTPUT (SDA)

The SDA is a bidirectional serial data input/output pin for a 2-Wire slave device and is used to transfer data into and out of the device. It receives device address, opcode, wiper register address and data sent from an 2-Wire master at the rising edge of the serial clock SCL, and it shifts out data after each falling edge of the serial clock SCL.

It is an open drain output and may be wire-ORed with any number of open drain or open collector outputs. An open drain output requires the use of a pull-up resistor. For selecting typical values, refer to the guidelines for calculating typical values on the bus pull-up resistors graph.

SERIAL CLOCK (SCL)

This input is used by 2-Wire master to supply 2-Wire serial clock to the X9269.

DEVICE ADDRESS (A3–A0)

The address inputs are used to set the least significant 4 bits of the 8-bit slave address. A match in the slave address serial data stream must be made with the Address input in order to initiate communication with the X9269. A maximum of 16 devices may occupy the 2-Wire serial bus.

Potentiometer Pins

R_H, R_L

The R_H and R_L pins are equivalent to the terminal connections on a mechanical potentiometer. Since there are 2 potentiometers, there are 2 sets of R_H and R_L such that R_{H0} and R_{L0} are the terminals of POT 0 and so on.

R_W

The wiper pin are equivalent to the wiper terminal of a mechanical potentiometer. Since there are 4 potentiometers, there are 2 sets of R_W such that R_{W0} is the terminal of POT 0 and so on.

Bias Supply Pins

SYSTEM SUPPLY VOLTAGE (V_{CC}) AND SUPPLY GROUND (V_{SS})

The V_{CC} pin is the system supply voltage. The V_{SS} pin is the system ground.

Other Pins

No CONNECT

No connect pins should be left open. This pins are used for Xicor manufacturing and testing purposes.

HARDWARE WRITE PROTECT INPUT (\overline{WP})

The \overline{WP} pin when LOW prevents nonvolatile writes to the Data Registers.

X9269

PRINCIPLES OF OPERATION

The X9269 is an integrated microcircuit incorporating four resistor arrays and their associated registers and counters and the serial interface logic providing direct communication between the host and the digitally controlled potentiometers. This section provides a detailed description of the following:

- Resistor Array Description
- Serial Interface Description
- Instruction and Register Description.

Array Description

The X9269 is comprised of a resistor array (see Figure 1). Each array contains 255 discrete resistive segments that are connected in series. The physical ends of each array are equivalent to the fixed terminals of a mechanical potentiometer (R_H and R_L inputs).

At both ends of each array and between each resistor segment is a CMOS switch connected to the wiper (R_W) output. Within each individual array only one switch may be turned on at a time.

These switches are controlled by a Wiper Counter Register (WCR). The 8-bits of the WCR (WCR[7:0]) are decoded to select, and enable, one of 256 switches (see Table 1).

The WCR may be written directly. These Data Registers can be read and written by the host system.

Power Up and Down Requirements.

There are no restrictions on the power-up or power-down conditions of V_{CC} and the voltages applied to the potentiometer pins provided that V_{CC} is always more positive than or equal to V_H , V_L , and V_W , i.e., $V_{CC} \geq V_H, V_L, V_W$. The V_{CC} ramp rate specification is always in effect.

Figure 1. Detailed Potentiometer Block Diagram

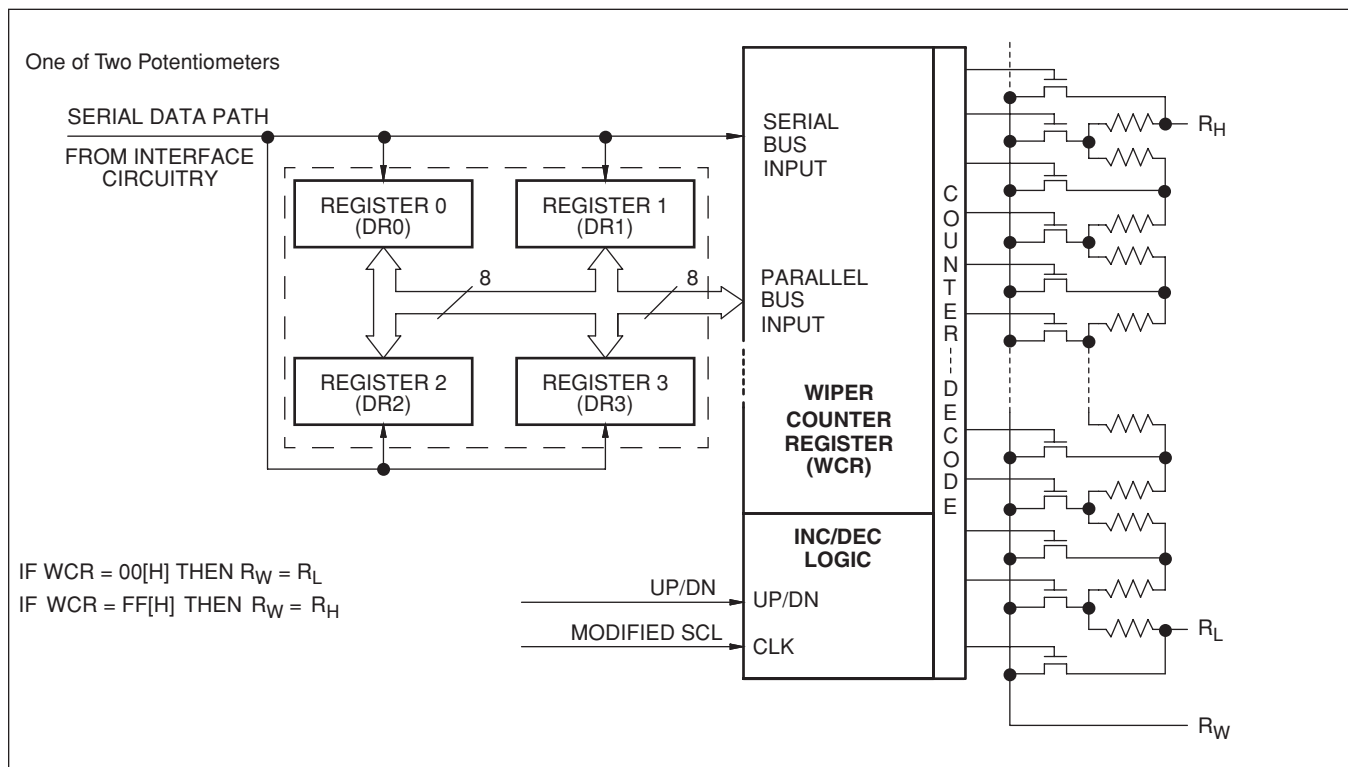

SERIAL INTERFACE DESCRIPTION

Serial Interface

The X9269 supports a bidirectional bus oriented protocol. The protocol defines any device that sends data onto the bus as a transmitter and the receiving device as the receiver. The device controlling the transfer is a master and the device being controlled is the slave. The master will always initiate data transfers and provide the clock for both transmit and receive operations. Therefore, the X9269 will be considered a slave device in all applications.

Clock and Data Conventions

Data states on the SDA line can change only during SCL LOW periods. SDA state changes during SCL HIGH are reserved for indicating start and stop conditions. See Figure 2.

Start Condition

All commands to the X9269 are preceded by the start condition, which is a HIGH to LOW transition of SDA while SCL is HIGH. The X9269 continuously monitors the SDA and SCL lines for the start condition and will not respond to any command until this condition is met. See Figure 2.

Stop Condition

All communications must be terminated by a stop condition, which is a LOW to HIGH transition of SDA while SCL is HIGH. See Figure 2.

Acknowledge

Acknowledge is a software convention used to provide a positive handshake between the master and slave devices on the bus to indicate the successful receipt of data. The transmitting device, either the master or the slave, will release the SDA bus after transmitting eight bits. The master generates a ninth clock cycle and during this period the receiver pulls the SDA line LOW to acknowledge that it successfully received the eight bits of data.

The X9269 will respond with an acknowledge after recognition of a start condition and its slave address and once again after successful receipt of the command byte. If the command is followed by a data byte the X9269 will respond with a final acknowledge. See Figure 2.

Figure 2. Acknowledge Response from Receiver

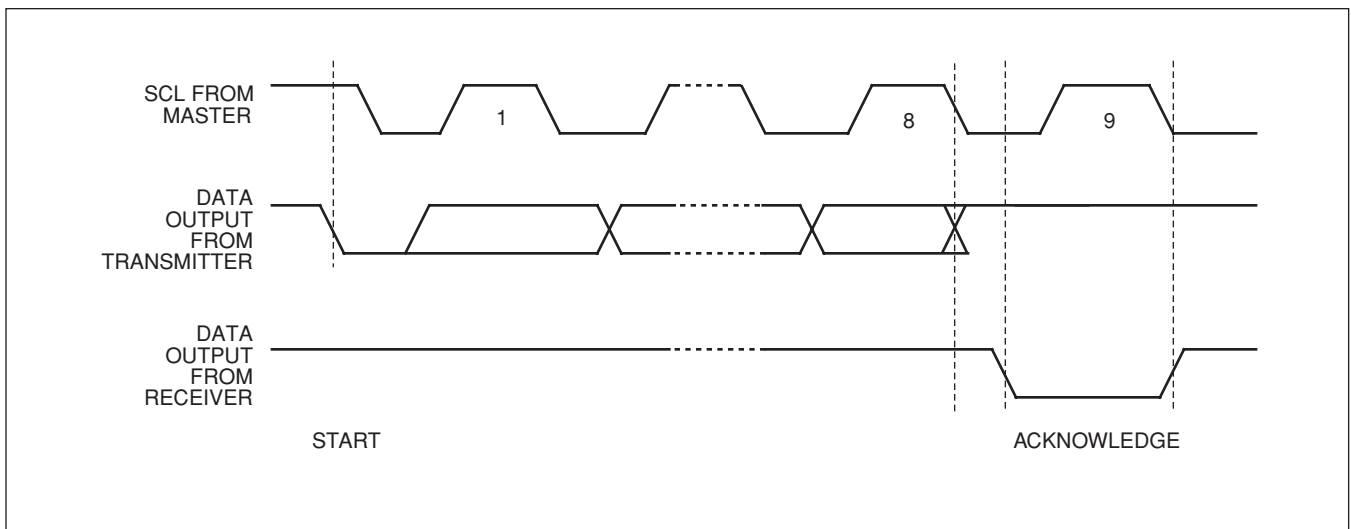

Acknowledge Polling

The disabling of the inputs, during the internal nonvolatile write operation, can be used to take advantage of the typical 5ms EEPROM write cycle time. Once the stop condition is issued to indicate the end of the nonvolatile write command the X9269 initiates the internal write cycle. ACK polling, Flow 1, can be initiated immediately. This involves issuing the start condition followed by the device slave address. If the X9269 is still busy with the write operation no ACK will be returned. If the X9269 has completed the write operation an ACK will be returned and the master can then proceed with the next operation.

FLOW 1: ACK Polling Sequence

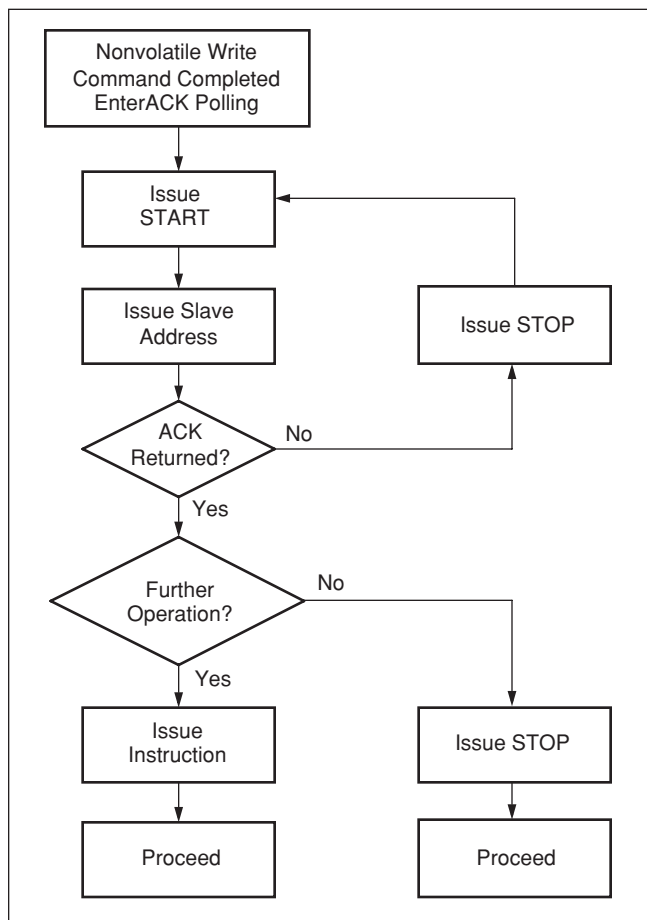

INSTRUCTION AND REGISTER DESCRIPTION

Instructions

DEVICE ADDRESSING: IDENTIFICATION BYTE (ID AND A)

The first byte sent to the X9269 from the host is called the Identification Byte. The most significant four bits of the slave address are a device type identifier. The ID[3:0] bits is the device id for the X9269; this is fixed as 0101[B] (refer to Table 1).

The A[3:0] bits in the ID byte is the internal slave address. The physical device address is defined by the state of the A3-A0 input pins. The slave address is externally specified by the user. The X9269 compares the serial data stream with the address input state; a successful compare of both address bits is required for the X9269 to successfully continue the command sequence. Only the device which slave address matches the incoming device address sent by the master executes the instruction. The A3-A0 inputs can be actively driven by CMOS input signals or tied to V_{CC} or V_{SS}.

INSTRUCTION BYTE (I)

The next byte sent to the X9269 contains the instruction and register pointer information. The three most significant bits are used provide the instruction opcode I [3:0]. The RB and RA bits point to one of the four Data Registers of each associated XDCP. The least significant bit points to one of two Wiper Counter Registers or Pots. The format is shown in Table 2.

Register Selection

Register Selected	RB	RA
DR0	0	0
DR1	0	1
DR2	1	0
DR3	1	1

Table 1. Identification Byte Format

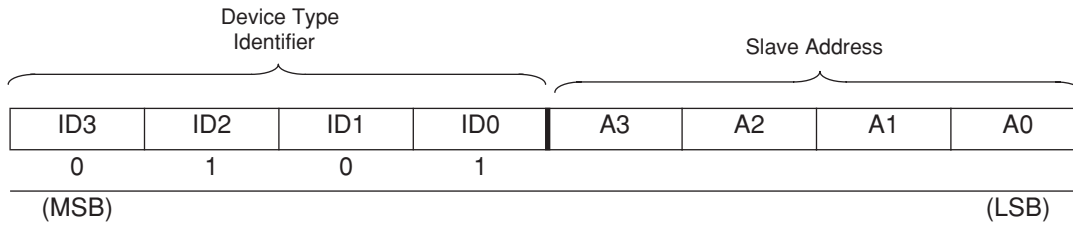

Table 2. Instruction Byte Format

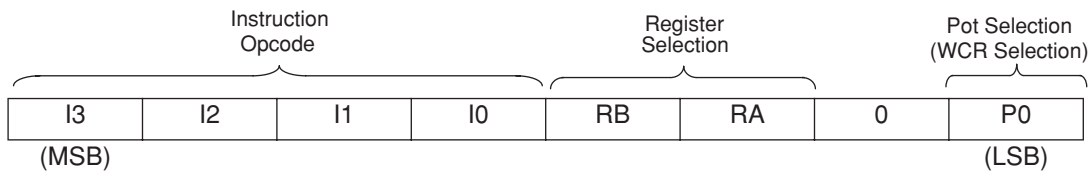

Table 3. Instruction Set

Instruction	Instruction Set								Operation
	I3	I2	I1	I0	RB	RA	0	P0	
Read Wiper Counter Register	1	0	0	1	0	0	0	1/0	Read the contents of the Wiper Counter Register pointed to by P0
Write Wiper Counter Register	1	0	1	0	0	0	0	1/0	Write new value to the Wiper Counter Register pointed to by P0
Read Data Register	1	0	1	1	1/0	1/0	0	1/0	Read the contents of the Data Register pointed to by P0 and RB-RA
Write Data Register	1	1	0	0	1/0	1/0	0	1/0	Write new value to the Data Register pointed to by P0 and RB-RA
XFR Data Register to Wiper Counter Register	1	1	0	1	1/0	1/0	0	1/0	Transfer the contents of the Data Register pointed to by P0 and RB-RA to its associated Wiper Counter Register
XFR Wiper Counter Register to Data Register	1	1	1	0	1/0	1/0	0	1/0	Transfer the contents of the Wiper Counter Register pointed to by P0 to the Data Register pointed to by RB-RA
Global XFR Data Registers to Wiper Counter Registers	0	0	0	1	1/0	1/0	0	0	Transfer the contents of the Data Registers pointed to by RB-RA of all four pots to their respective Wiper Counter Registers
Global XFR Wiper Counter Registers to Data Register	1	0	0	0	1/0	1/0	0	0	Transfer the contents of both Wiper Counter Registers to their respective data Registers pointed to by RB-RA of all four pots
Increment/Decrement Wiper Counter Register	0	0	1	0	0	0	0	1/0	Enable Increment/decrement of the Control Latch pointed to by P0

Note: 1/0 = data is one or zero

DEVICE DESCRIPTION

Wiper Counter Register (WCR)

The X9269 contains two Wiper Counter Registers, one for each DCP potentiometer. The Wiper Counter Register can be envisioned as a 8-bit parallel and serial load counter with its outputs decoded to select one of 256 switches along its resistor array. The contents of the WCR can be altered in four ways: it may be written directly by the host via the Write Wiper Counter Register instruction (serial load); it may be written indirectly by transferring the contents of one of four associated data registers via the XFR Data Register instruction (parallel load); it can be modified one step at a time by the Increment/Decrement instruction (see Instruction section for more details). Finally, it is loaded with the contents of its Data Register zero (DR0) upon power-up.

The Wiper Counter Register is a volatile register; that is, its contents are lost when the X9269 is powered-down. Although the register is automatically loaded with the value in DR0 upon power-up, this may be different from the value present at power-down. Power-up guidelines are recommended to ensure proper loadings of the DR0 value into the WCR (See Design Considerations Section).

Data Registers (DR)

Each potentiometer has four 8-bit nonvolatile Data Registers. These can be read or written directly by the host. Data can also be transferred between any of the four Data Registers and the associated Wiper Counter Register. All operations changing data in one of the data registers is a nonvolatile operation and will take a maximum of 10ms.

If the application does not require storage of multiple settings for the potentiometer, the Data Registers can be used as regular memory locations for system parameters or user preference data.

Bit [7:0] are used to store one of the 256 wiper positions (0~255).

Table 1. Wiper counter Register, WCR (8-bit), WCR[7:0]: Used to store the current wiper position (Volatile, V).

WCR7	WCR6	WCR5	WCR4	WCR3	WCR2	WCR1	WCR0
V	V	V	V	V	V	V	V
(MSB)							(LSB)

Table 2. Data Register, DR (8-bit), Bit [7:0]: Used to store wiper positions or data (Nonvolatile, NV).

Bit 7	Bit 6	Bit 5	Bit 4	Bit 3	Bit 2	Bit 1	Bit 0
NV	NV	NV	NV	NV	NV	NV	NV
MSB							LSB

DEVICE DESCRIPTION

Instructions

Four of the nine instructions are three bytes in length. These instructions are:

- **Read Wiper Counter Register** – read the current wiper position of the selected potentiometer,
- **Write Wiper Counter Register** – change current wiper position of the selected potentiometer,
- **Read Data Register** – read the contents of the selected Data Register;
- **Write Data Register** – write a new value to the selected Data Register.

The basic sequence of the three byte instructions is illustrated in Figure 4. These three-byte instructions exchange data between the WCR and one of the Data Registers. A transfer from a Data Register to a WCR is essentially a write to a static RAM, with the static RAM controlling the wiper position. The response of the wiper to this action will be delayed by t_{WRL} . A transfer from the WCR (current wiper position), to a Data Register is a write to nonvolatile memory and takes a minimum of t_{WR} to complete. The transfer can occur between one of the four potentiometers and one of its associated registers; or it may occur globally, where the transfer occurs between all potentiometers and one associated register

Four instructions require a two-byte sequence to complete. These instructions transfer data between the host and the X9269; either between the host and one of the data registers or directly between the host and the Wiper Counter Register. These instructions are:

- **XFR Data Register to Wiper Counter Register** – This transfers the contents of one specified Data Register to the associated Wiper Counter Register.
- **XFR Wiper Counter Register to Data Register** – This transfers the contents of the specified Wiper Counter Register to the specified associated Data Register.
- **Global XFR Data Register to Wiper Counter Register** – This transfers the contents of all specified Data Registers to the associated Wiper Counter Registers.
- **Global XFR Wiper Counter Register to Data Register** – This transfers the contents of all Wiper Counter Registers to the specified associated Data Registers.

INCREMENT/DECREMENT COMMAND

The final command is Increment/Decrement (Figure 5 and 6). The Increment/Decrement command is different from the other commands. Once the command is issued and the X9269 has responded with an acknowledge, the master can clock the selected wiper up and/or down in one segment steps; thereby, providing a fine tuning capability to the host. For each SCL clock pulse (t_{HIGH}) while SDA is HIGH, the selected wiper will move one resistor segment towards the R_H terminal. Similarly, for each SCL clock pulse while SDA is LOW, the selected wiper will move one resistor segment towards the R_L terminal.

See Instruction format for more details.

Figure 3. Two-Byte Instruction Sequence

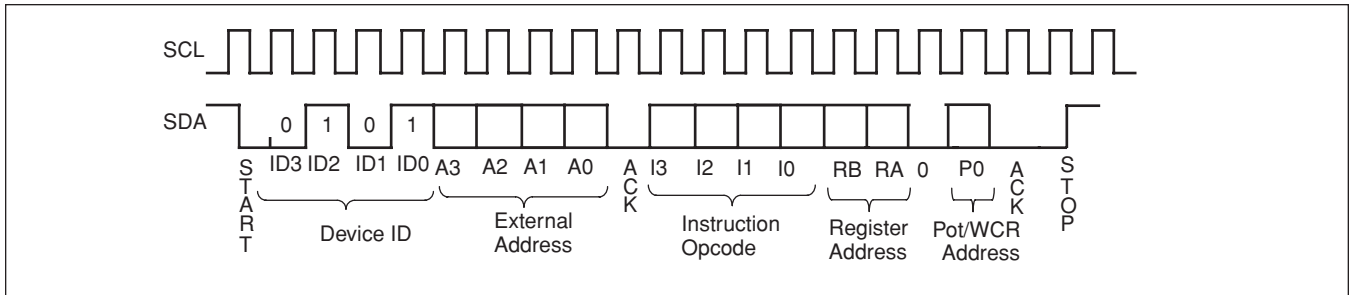

Figure 4. Three-Byte Instruction Sequence

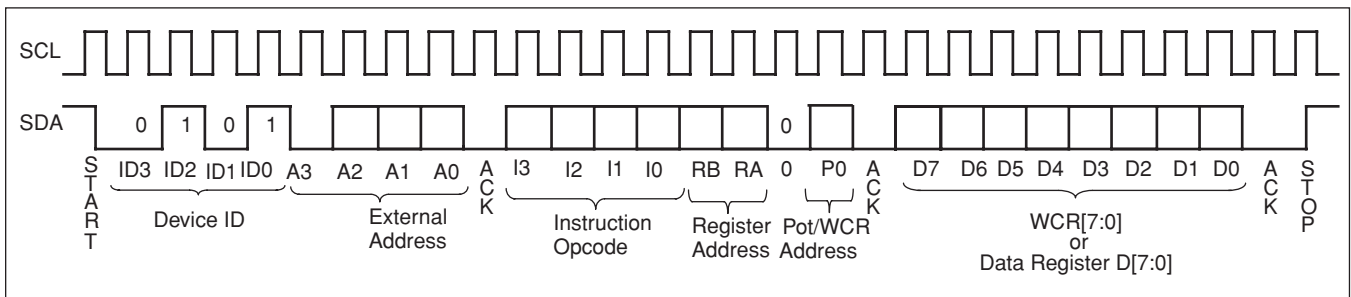

Figure 5. Increment/Decrement Instruction Sequence

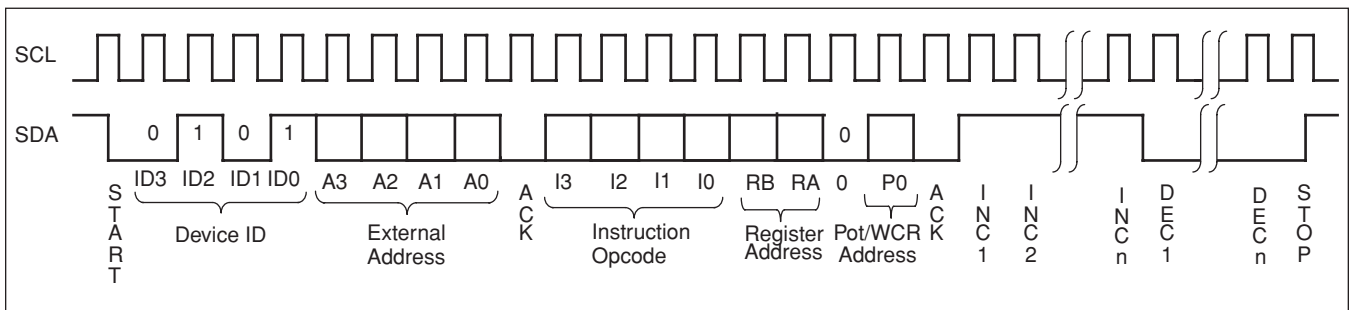
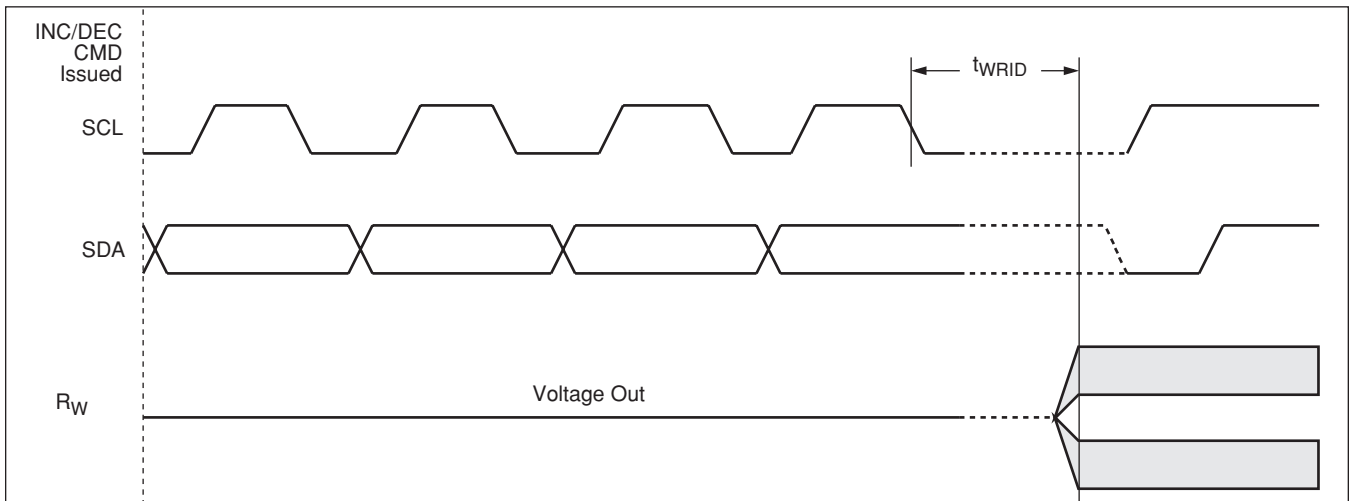

Figure 6. Increment/Decrement Timing Limits



X9269

INSTRUCTION FORMAT

Read Wiper Counter Register (WCR)

S T A R T	Device Type Identifier				Device Addresses				S A C K	Instruction Opcode				DR/WCR Addresses				S A C K	Wiper Position (Sent by X9269 on SDA)								M A C K	S T O P
	0	1	0	1	A3	A2	A1	A0		1	0	0	1	0	0	0	P0		W C R 7	W C R 6	W C R 5	W C R 4	W C R 3	W C R 2	W C R 1	W C R 0		
	0	1	0	1	A3	A2	A1	A0		1	0	0	1	0	0	0	P0		W C R 7	W C R 6	W C R 5	W C R 4	W C R 3	W C R 2	W C R 1	W C R 0		

Write Wiper Counter Register (WCR)

S T A R T	Device Type Identifier				Device Addresses				S A C K	Instruction Opcode				DR/WCR Addresses				S A C K	Wiper Position (Sent by Master on SDA)								S A C K	S T O P
	0	1	0	1	A3	A2	A1	A0		1	0	1	0	0	0	0	P0		W C R 7	W C R 6	W C R 5	W C R 4	W C R 3	W C R 2	W C R 1	W C R 0		
	0	1	0	1	A3	A2	A1	A0		1	0	1	0	0	0	0	P0		W C R 7	W C R 6	W C R 5	W C R 4	W C R 3	W C R 2	W C R 1	W C R 0		

Read Data Register (DR)

S T A R T	Device Type Identifier				Device Addresses				S A C K	Instruction Opcode				DR/WCR Addresses				S A C K	Wiper Position (Sent by X9269 on SDA)								M A C K	S T O P
	0	1	0	1	A3	A2	A1	A0		1	0	1	1	RB	RA	0	P0		W C R 7	W C R 6	W C R 5	W C R 4	W C R 3	W C R 2	W C R 1	W C R 0		
	0	1	0	1	A3	A2	A1	A0		1	0	1	1	RB	RA	0	P0		W C R 7	W C R 6	W C R 5	W C R 4	W C R 3	W C R 2	W C R 1	W C R 0		

Write Data Register (DR)

S T A R T	Device Type Identifier				Device Addresses				S A C K	Instruction Opcode				DR/WCR Addresses				S A C K	Wiper Position (Sent by Master on SDA)								S A C K	S T O P	H I G H - V O L T A G E W R I T E C Y C L E
	0	1	0	1	A3	A2	A1	A0		1	1	0	0	RB	RA	0	P0		W C R 7	W C R 6	W C R 5	W C R 4	W C R 3	W C R 2	W C R 1	W C R 0			
	0	1	0	1	A3	A2	A1	A0		1	1	0	0	RB	RA	0	P0		W C R 7	W C R 6	W C R 5	W C R 4	W C R 3	W C R 2	W C R 1	W C R 0			

Global XFR Data Register (DR) to Wiper Counter Register (WCR)

S T A R T	Device Type Identifier				Device Addresses				S A C K	Instruction Opcode				DR/WCR Addresses				S A C K	S T O P
	0	1	0	1	A3	A2	A1	A0		0	0	0	1	RB	RA	0	0		
	0	1	0	1	A3	A2	A1	A0		0	0	0	1	RB	RA	0	0		

Global XFR Wiper Counter Register (WCR) to Data Register (DR)

S T A R T	Device Type Identifier				Device Addresses				S A C K	Instruction Opcode				DR/WCR Addresses				S A C K	S T O P	HIGH-VOLTAGE WRITE CYCLE
	0	1	0	1	A3	A2	A1	A0		1	0	0	0	RB	RA	0	0			
	0	1	0	1	A3	A2	A1	A0		1	0	0	0	RB	RA	0	0			

Transfer Wiper Counter Register (WCR) to Data Register (DR)

S T A R T	Device Type Identifier				Device Addresses				S A C K	Instruction Opcode				DR/WCR Addresses				S A C K	S T O P	HIGH-VOLTAGE WRITE CYCLE
	0	1	0	1	A3	A2	A1	A0		1	1	1	0	RB	RA	0	P0			
	0	1	0	1	A3	A2	A1	A0		1	1	1	0	RB	RA	0	P0			

Transfer Data Register (DR) to Wiper Counter Register (WCR)

S T A R T	Device Type Identifier				Device Addresses				S A C K	Instruction Opcode				DR/WCR Addresses				S A C K	S T O P	
	0	1	0	1	A3	A2	A1	A0		1	1	0	1	RB	RA	0	P0			
	0	1	0	1	A3	A2	A1	A0		1	1	0	1	RB	RA	0	P0			

Increment/Decrement Wiper Counter Register (WCR)

S T A R T	Device Type Identifier				Device Addresses				S A C K	Instruction Opcode				DR/WCR Addresses				Increment/Decrement (Sent by Master on SDA)				S T O P				
	0	1	0	1	A3	A2	A1	A0		0	0	1	0	0	0	0	P0	I/D	I/D	I/D	I/D
	0	1	0	1	A3	A2	A1	A0		0	0	1	0	0	0	0	P0	I/D	I/D	I/D	I/D	

- Notes:** (1) "MACK"/"SACK": stands for the acknowledge sent by the master/slave.
 (2) "A3 ~ A0": stands for the device addresses sent by the master.
 (3) "X": indicates that it is a "0" for testing purpose but physically it is a "don't care" condition.
 (4) "I": stands for the increment operation, SDA held high during active SCL phase (high).
 (5) "D": stands for the decrement operation, SDA held low during active SCL phase (high).

X9269

ABSOLUTE MAXIMUM RATINGS

Temperature under bias-65°C to +135°C
 Storage temperature-65°C to +150°C
 Voltage on SCL, SDA any address input
 with respect to V_{SS}-1V to +7V
 $\Delta V = | (V_H - V_L) |$ 5.5V
 Lead temperature (soldering, 10 seconds).....300°C
 I_W (10 seconds) ± 6 mA

COMMENT

Stresses above those listed under “Absolute Maximum Ratings” may cause permanent damage to the device. This is a stress rating only; the functional operation of the device (at these or any other conditions above those listed in the operational sections of this specification) is not implied. Exposure to absolute maximum rating conditions for extended periods may affect device reliability.

RECOMMENDED OPERATING CONDITIONS

Temp	Min.	Max.
Commercial	0°C	+70°C
Industrial	-40°C	+85°C

Device	Supply Voltage (V_{CC}) ⁽⁴⁾ Limits
X9269	5V $\pm 10\%$
X9269-2.7	2.7V to 5.5V

POTENTIOMETER CHARACTERISTICS (Over recommended industrial (2.7V) operating conditions unless otherwise stated.)

Symbol	Parameter	Limits				Test Conditions
		Min.	Typ.	Max.	Units	
R_{TOTAL}	End to End Resistance		100		k Ω	T version
R_{TOTAL}	End to End Resistance		50		k Ω	U version
	End to End Resistance Tolerance			± 20	%	
	Power Rating			50	mW	25°C, each pot
I_W	Wiper Current			± 3	mA	
R_W	Wiper Resistance			300	Ω	$I_W = \pm 3$ mA @ $V_{CC} = 3$ V
R_W	Wiper Resistance			150	Ω	$I_W = \pm 3$ mA @ $V_{CC} = 5$ V
V_{TERM}	Voltage on any R_H or R_L Pin	V_{SS}		V_{CC}	V	$V_{SS} = 0$ V
	Noise		-120		dBV	Ref: 1V
	Resolution		0.4		%	
	Absolute Linearity ⁽¹⁾			± 1	MI ⁽³⁾	$R_{W(n)}(actual) - R_{W(n)}(expected)$ ⁽⁵⁾
	Relative Linearity ⁽²⁾			± 0.6	MI ⁽³⁾	$R_{W(n+1)} - [R_{W(n)} + MI]$ ⁽⁵⁾
	Temperature Coefficient of R_{TOTAL}		± 300		ppm/°C	
	Ratiometric Temp. Coefficient			20	ppm/°C	
$C_H/C_L/C_W$	Potentiometer Capacitances		10/10/25		pF	See Macro model
I_{al}	R_W, R_H, R_L Leakage		0.1	10.0	μ A	Device in stand by. $V_{in} = V_{SS}$ to V_{CC}

- Notes:** (1) Absolute linearity is utilized to determine actual wiper voltage versus expected voltage as determined by wiper position when used as a potentiometer.
 (2) Relative linearity is utilized to determine the actual change in voltage between two successive tap positions when used as a potentiometer. It is a measure of the error in step size.
 (3) $MI = R_{TOT} / 255$ or $(R_H - R_L) / 255$, single pot
 (4) During power up $V_{CC} > V_H, V_L$, and V_W .
 (5) $n = 0, 1, 2, \dots, 255$; $m = 0, 1, 2, \dots, 254$.

X9269

D.C. OPERATING CHARACTERISTICS (Over the recommended operating conditions unless otherwise specified.)

Symbol	Parameter	Limits				Test Conditions
		Min.	Typ.	Max.	Units	
I _{CC1}	V _{CC} supply current (active)			400	μA	f _{SCL} = 400KHz; V _{CC} = +6V; SDA = Open; (for 2-Wire, Active, Read and
I _{CC2}	V _{CC} supply current (nonvolatile write)		1	5	mA	f _{SCL} = 400KHz; V _{CC} = +6V; SDA = Open; (for 2-Wire, Active, Nonvolatile Write State only)
I _{SB}	V _{CC} current (standby)			5	μA	V _{CC} = +6V; V _{IN} = V _{SS} or V _{CC} ; SDA = V _{CC} ; (for 2-Wire, Standby State only)
I _{LI}	Input leakage current			10	μA	V _{IN} = V _{SS} to V _{CC}
I _{LO}	Output leakage current			10	μA	V _{OUT} = V _{SS} to V _{CC}
V _{IH}	Input HIGH voltage	V _{CC} × 0.7		V _{CC} + 1	V	
V _{IL}	Input LOW voltage	-1		V _{CC} × 0.3	V	
V _{OL}	Output LOW voltage			0.4	V	I _{OL} = 3mA
V _{OH}	Output HIGH voltage	V _{CC} - 0.8			V	I _{OH} = -1mA, V _{CC} ≥ +3V
V _{OH}	Output HIGH voltage	V _{CC} - 0.4			V	I _{OH} = -0.4mA, V _{CC} ≤ +3V

ENDURANCE AND DATA RETENTION

Parameter	Min.	Units
Minimum endurance	100,000	Data changes per bit per register
Data retention	100	years

CAPACITANCE

Symbol	Test	Max.	Units	Test Conditions
C _{IN/OUT} ⁽⁶⁾	Input / Output capacitance (SDA)	8	pF	V _{OUT} = 0V
C _{IN} ⁽⁶⁾	Input capacitance (SCL, \overline{WP} , A3, A2, A1 and A0)	6	pF	V _{IN} = 0V

POWER-UP TIMING

Symbol	Parameter	Min.	Max.	Units
t _r V _{CC} ⁽⁶⁾	V _{CC} Power-up rate	0.2	50	V/ms
t _{PUR} ⁽⁷⁾	Power-up to initiation of read operation		1	ms

POWER UP AND DOWN REQUIREMENTS

There are no restrictions on the power-up or power-down conditions of V_{CC} and the voltages applied to the potentiometer pins provided that V_{CC} is always more positive than or equal to V_H, V_L, and V_W, i.e., V_{CC} ≥ V_H, V_L, V_W. The V_{CC} power-up timing spec is always in effect.

A.C. TEST CONDITIONS

Input Pulse Levels	V _{CC} × 0.1 to V _{CC} × 0.9
Input rise and fall times	10ns
Input and output timing level	V _{CC} × 0.5

Notes: (6) This parameter is not 100% tested

(7) t_{PUR} and t_{PUD} are the delays required from the time the (last) power supply (V_{CC}) is stable until the specific instruction can be issued. These parameters are periodically sampled and not 100% tested.

X9269

EQUIVALENT A.C. LOAD CIRCUIT

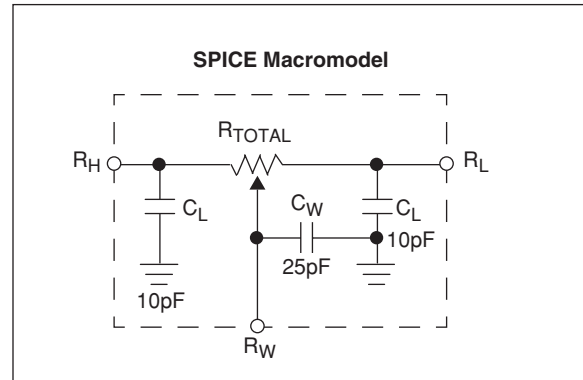
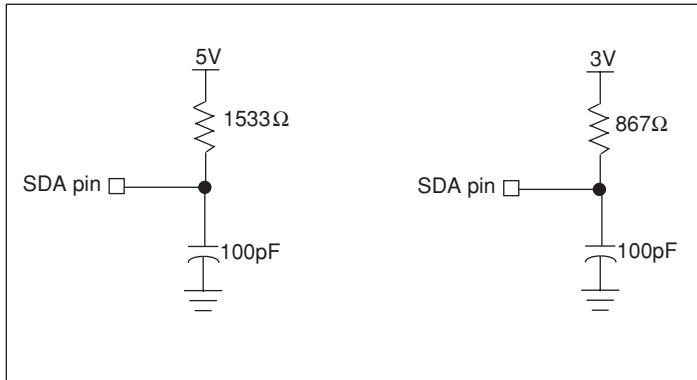

AC TIMING

Symbol	Parameter	Min.	Max.	Units
f_{SCL}	Clock Frequency		400	kHz
t_{CYC}	Clock Cycle Time	2500		ns
t_{HIGH}	Clock High Time	600		ns
t_{LOW}	Clock Low Time	1300		ns
$t_{SU:STA}$	Start Setup Time	600		ns
$t_{HD:STA}$	Start Hold Time	600		ns
$t_{SU:STO}$	Stop Setup Time	600		ns
$t_{SU:DAT}$	SDA Data Input Setup Time	100		ns
$t_{HD:DAT}$	SDA Data Input Hold Time	30		ns
t_R	SCL and SDA Rise Time		300	ns
t_F	SCL and SDA Fall Time		300	ns
t_{AA}	SCL Low to SDA Data Output Valid Time		0.9	μs
t_{DH}	SDA Data Output Hold Time	0		ns
T_I	Noise Suppression Time Constant at SCL and SDA inputs	50		ns
t_{BUF}	Bus Free Time (Prior to Any Transmission)	1200		ns
$t_{SU:WPA}$	A0, A1, A2, A3 Setup Time	0		ns
$t_{HD:WPA}$	A0, A1, A2, A3 Hold Time	0		ns

X9269





HIGH-VOLTAGE WRITE CYCLE TIMING

Symbol	Parameter	Typ.	Max.	Units
t_{WR}	High-voltage write cycle time (store instructions)	5	10	ms

XDCP TIMING

Symbol	Parameter	Min.	Max.	Units
t_{WRPO}	Wiper response time after the third (last) power supply is stable	5	10	μ s
t_{WRL}	Wiper response time after instruction issued (all load instructions)	5	10	μ s

SYMBOL TABLE

WAVEFORM	INPUTS	OUTPUTS
	Must be steady	Will be steady
	May change from Low to High	Will change from Low to High
	May change from High to Low	Will change from High to Low
	Don't Care: Changes Allowed	Changing: State Not Known
	N/A	Center Line is High Impedance

TIMING DIAGRAMS

Start and Stop Timing

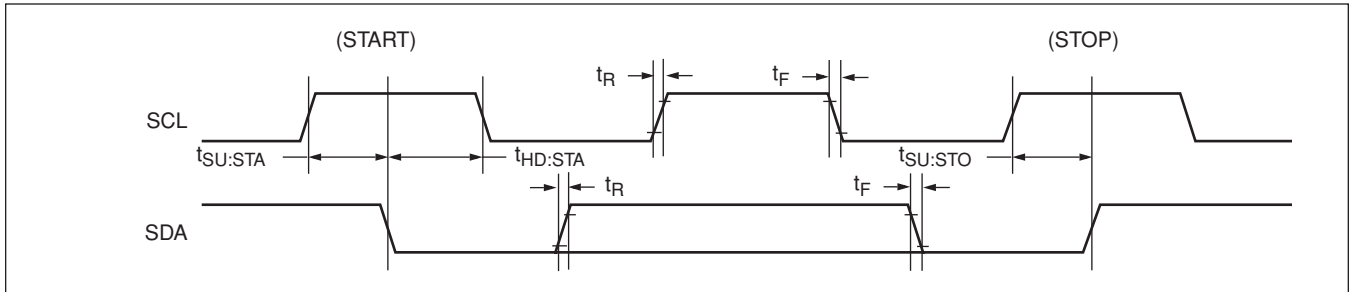

Input Timing

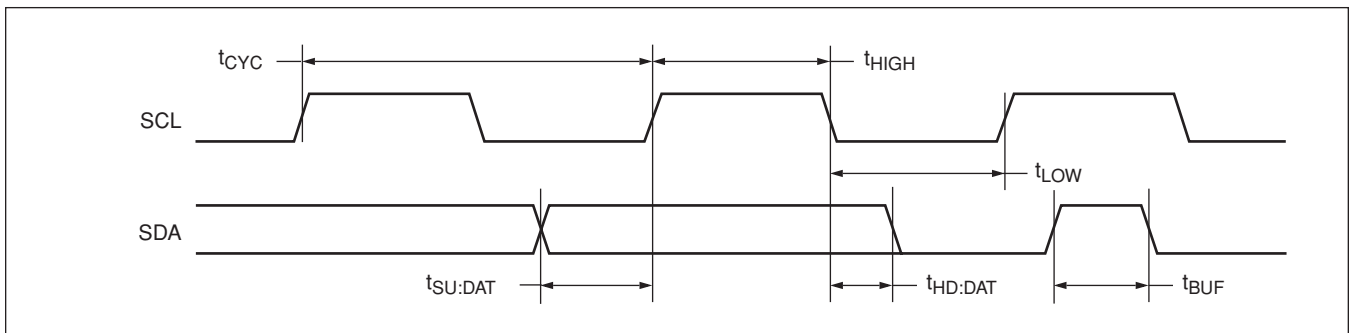

Output Timing

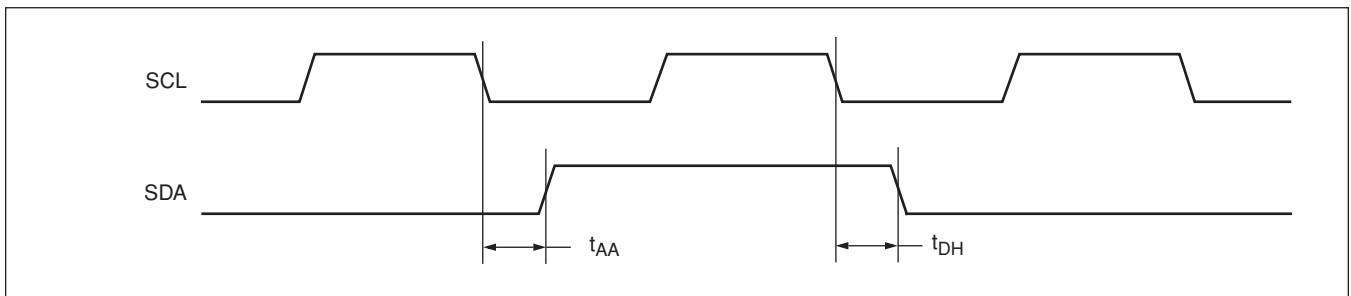

X9269

XDCP Timing (for All Load Instructions)

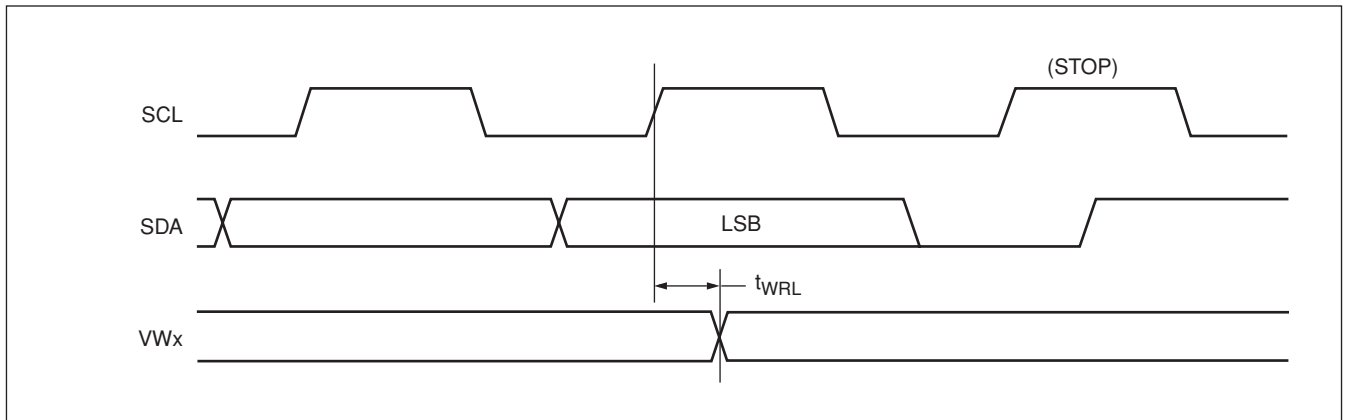

Write Protect and Device Address Pins Timing

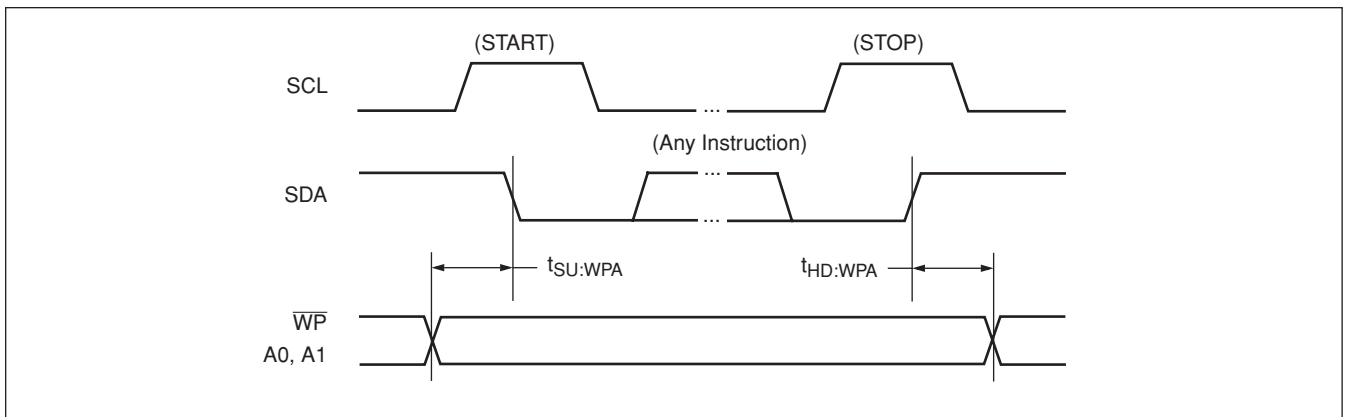

APPLICATIONS INFORMATION

Basic Configurations of Electronic Potentiometers

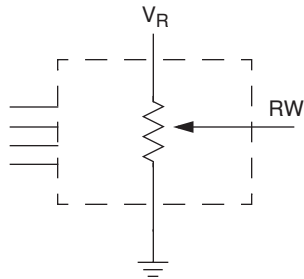

Three terminal Potentiometer;
Variable voltage divider

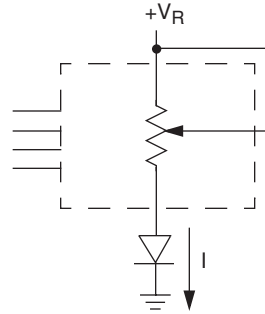

Two terminal Variable Resistor;
Variable current

Application Circuits

Noninverting Amplifier

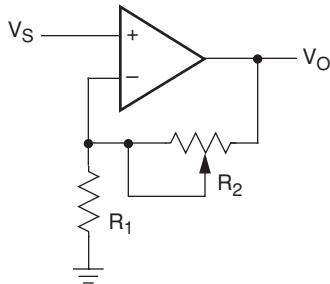

$$V_O = (1 + R_2/R_1) V_S$$

Voltage Regulator

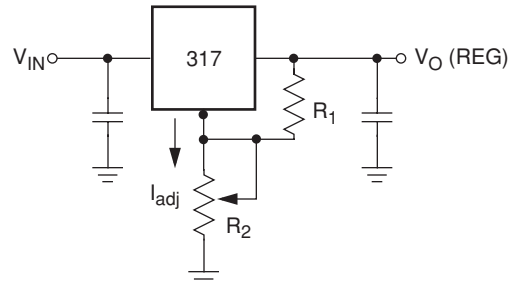

$$V_O (\text{REG}) = 1.25V (1 + R_2/R_1) + I_{\text{adj}} R_2$$

Offset Voltage Adjustment

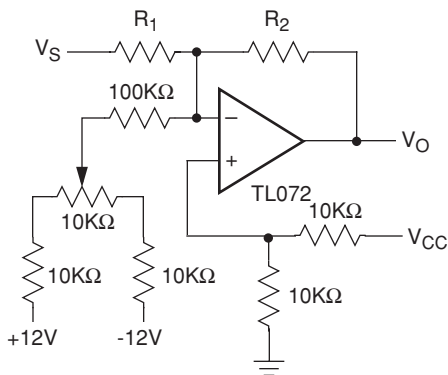

Comparator with Hysteresis

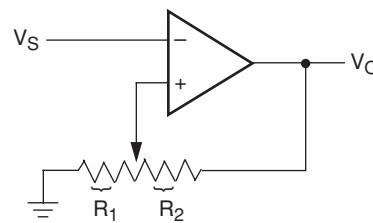

$$V_{UL} = \{R_1/(R_1 + R_2)\} V_O(\text{max})$$

$$R_{L_L} = \{R_1/(R_1 + R_2)\} V_O(\text{min})$$

Application Circuits (continued)

Attenuator

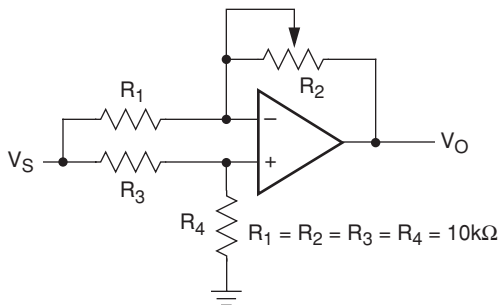

$$V_O = G V_S$$

$$-1/2 \leq G \leq +1/2$$

Filter

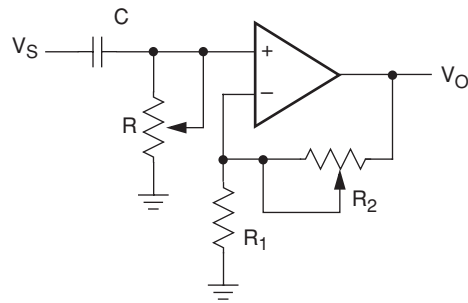

$$G_O = 1 + R_2/R_1$$

$$f_c = 1/(2\pi RC)$$

Inverting Amplifier

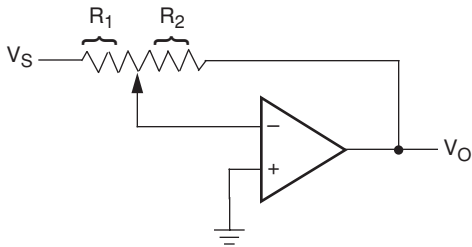

$$V_O = G V_S$$

$$G = -R_2/R_1$$

Equivalent L-R Circuit

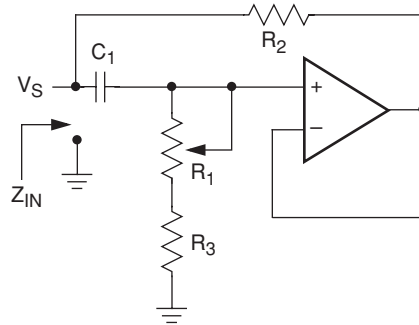

$$Z_{IN} = R_2 + s R_2 (R_1 + R_3) \quad C_1 = R_2 + s Leq$$

$$(R_1 + R_3) \gg R_2$$

Function Generator

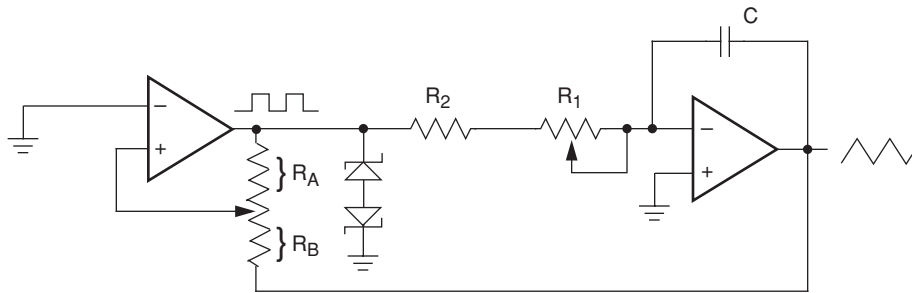

$$\text{frequency} \propto R_1, R_2, C$$

$$\text{amplitude} \propto R_A, R_B$$

PACKAGING INFORMATION

16-Bump Chip Scale Package (CSP B16)
Package Outline Drawing

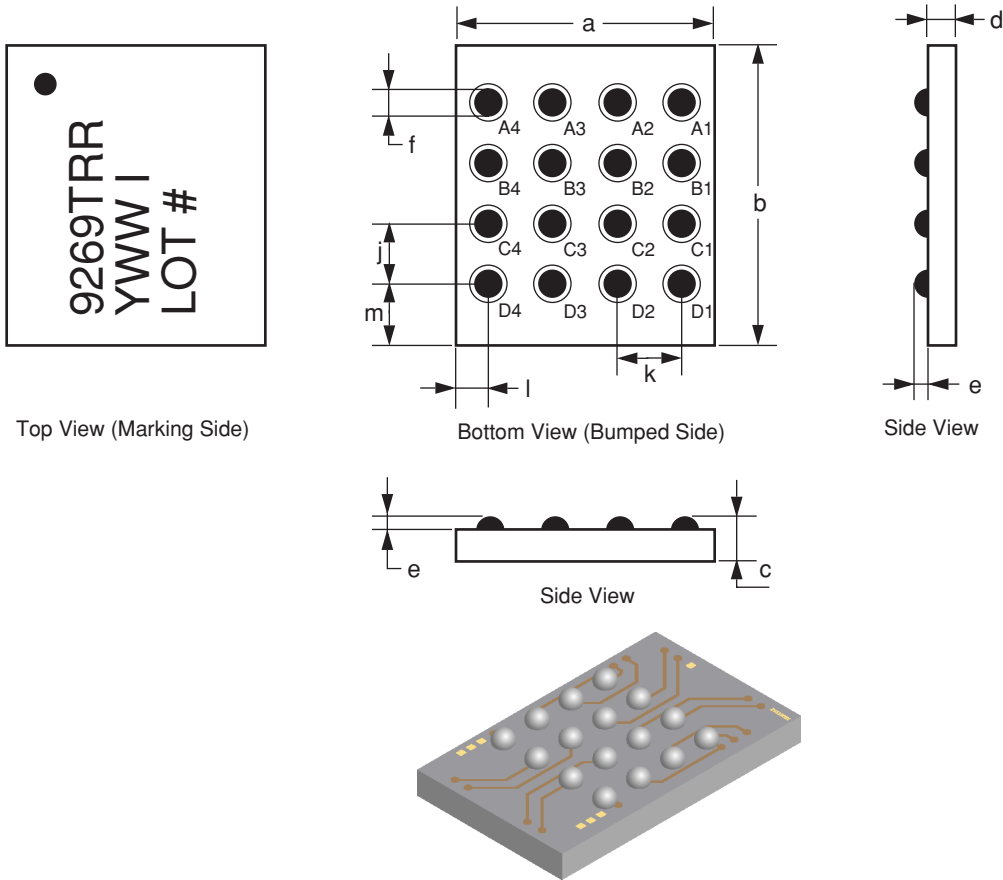

Top View (Marking Side)

Bottom View (Bumped Side)

Side View

Side View

Package Dimensions

	Symbol	Millimeters			Inches		
		Min	Nominal	Max	Min	Nominal	Max
Package Width	a	2.745	2.775	2.805			
Package Length	b	4.523	4.553	4.583			
Package Height	c	0.644	0.677	0.710			
Body Thickness	d	0.444	0.457	0.470			
Ball Height	e	0.200	0.220	0.240			
Ball Diameter	f	0.300	0.320	0.340			
Ball Pitch – Width	j		0.65				
Ball Pitch – Length	k		0.65				
Ball to Edge Spacing – Width	l	0.388	0.413	0.438			
Ball to Edge Spacing – Length	m	1.277	1.302	1.327			

Ball Matrix:

	4	3	2	1
A	R _{H1}	A1	A2	R _{H0}
B	R _{L1}	SDA	WP	R _{W0}
C	R _{W1}	A3	NC	R _{L0}
D	V _{ss}	SCL	A0	V _{cc}

X9269

PACKAGING INFORMATION

24-Lead Plastic, TSSOP, Package Code V24

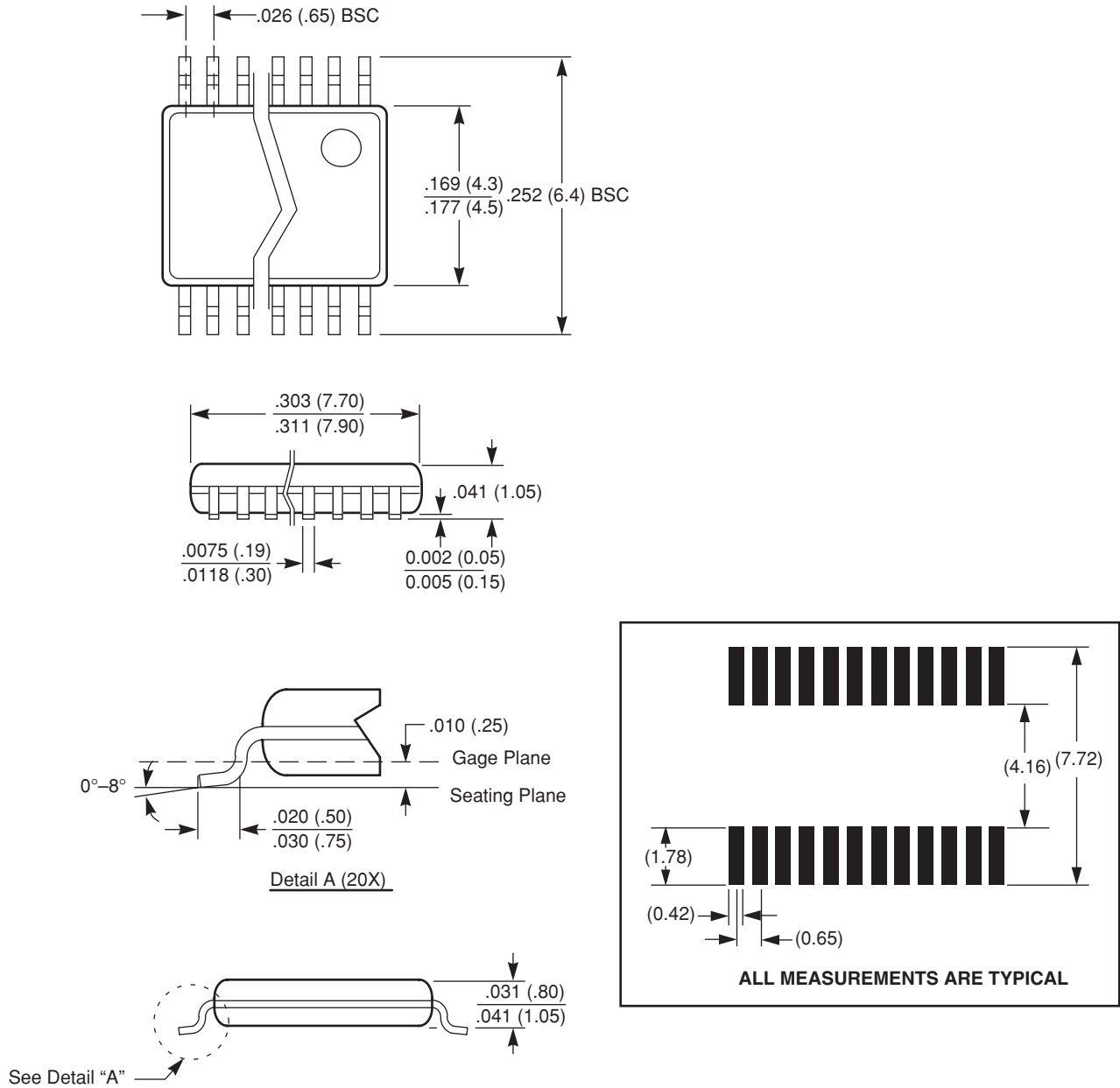

NOTE: ALL DIMENSIONS IN INCHES (IN PARENTHESES IN MILLIMETERS)

PACKAGING INFORMATION

24-Lead Plastic Small Outline Gull Wing Package Type S

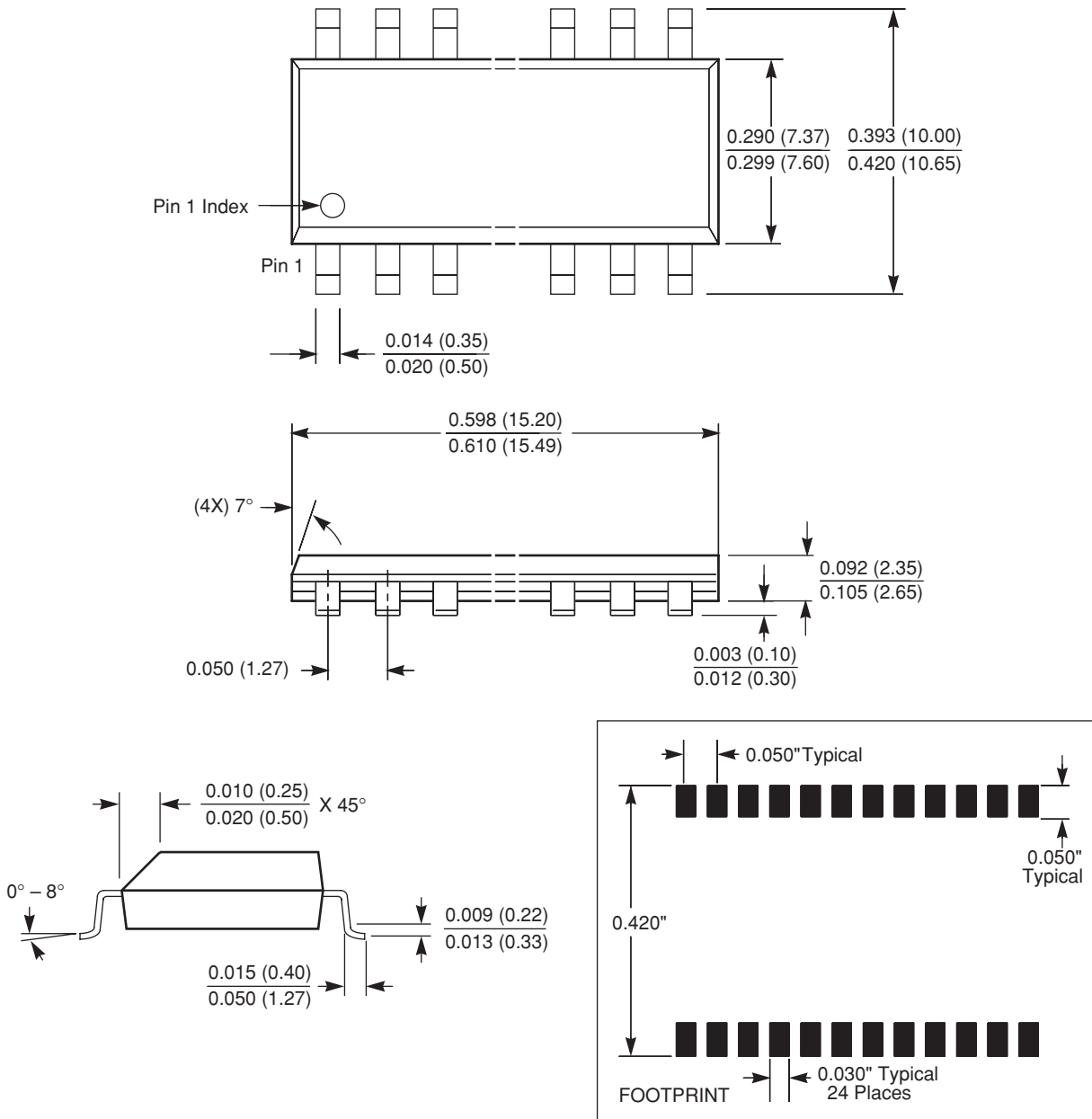

NOTE: ALL DIMENSIONS IN INCHES (IN PARENTHESES IN MILLIMETERS)

X9269

ORDERING INFORMATION

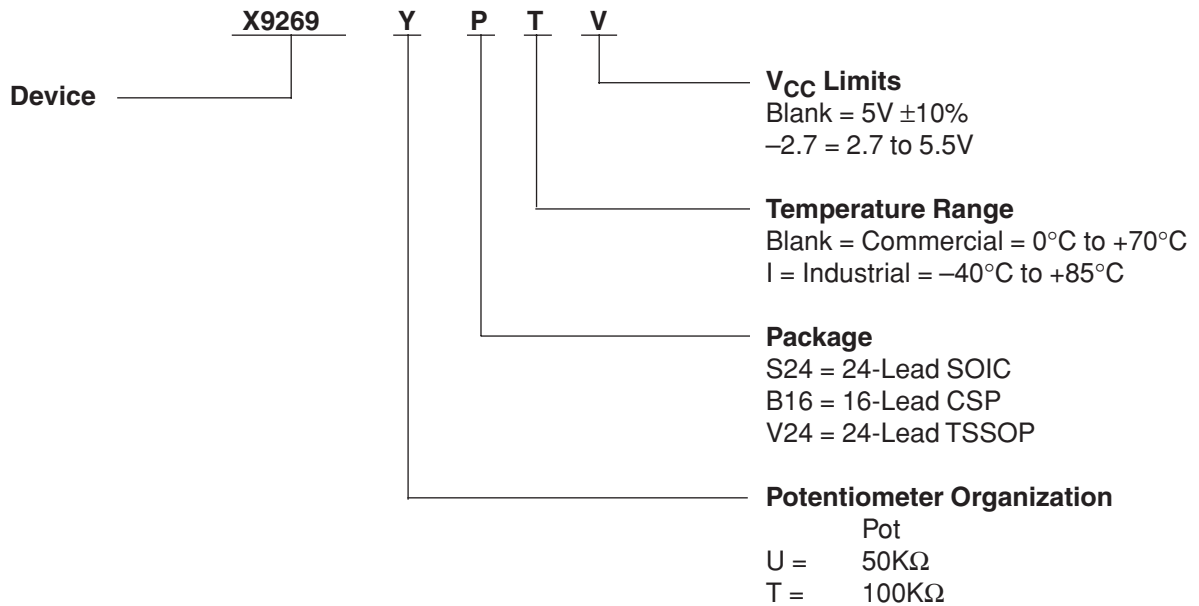

LIMITED WARRANTY

©Xicor, Inc. 2003 Patents Pending

Devices sold by Xicor, Inc. are covered by the warranty and patent indemnification provisions appearing in its Terms of Sale only. Xicor, Inc. makes no warranty, express, statutory, implied, or by description regarding the information set forth herein or regarding the freedom of the described devices from patent infringement. Xicor, Inc. makes no warranty of merchantability or fitness for any purpose. Xicor, Inc. reserves the right to discontinue production and change specifications and prices at any time and without notice.

Xicor, Inc. assumes no responsibility for the use of any circuitry other than circuitry embodied in a Xicor, Inc. product. No other circuits, patents, or licenses are implied.

COPYRIGHTS AND TRADEMARKS

Xicor, Inc., the Xicor logo, E²POT, XDCP, XBGA, AUTOSTORE, Direct Write cell, Concurrent Read-Write, PASS, MPS, PushPOT, Block Lock, IdentiPROM, E²KEY, X24C16, SecureFlash, and SerialFlash are all trademarks or registered trademarks of Xicor, Inc. All other brand and product names mentioned herein are used for identification purposes only, and are trademarks or registered trademarks of their respective holders.

U.S. PATENTS

Xicor products are covered by one or more of the following U.S. Patents: 4,326,134; 4,393,481; 4,404,475; 4,450,402; 4,486,769; 4,488,060; 4,520,461; 4,533,846; 4,599,706; 4,617,652; 4,668,932; 4,752,912; 4,829,482; 4,874,967; 4,883,976; 4,980,859; 5,012,132; 5,003,197; 5,023,694; 5,084,667; 5,153,880; 5,153,691; 5,161,137; 5,219,774; 5,270,927; 5,324,676; 5,434,396; 5,544,103; 5,587,573; 5,835,409; 5,977,585. Foreign patents and additional patents pending.

LIFE RELATED POLICY

In situations where semiconductor component failure may endanger life, system designers using this product should design the system with appropriate error detection and correction, redundancy and back-up features to prevent such an occurrence.

Xicor's products are not authorized for use in critical components in life support devices or systems.

1. Life support devices or systems are devices or systems which, (a) are intended for surgical implant into the body, or (b) support or sustain life, and whose failure to perform, when properly used in accordance with instructions for use provided in the labeling, can be reasonably expected to result in a significant injury to the user.
2. A critical component is any component of a life support device or system whose failure to perform can be reasonably expected to cause the failure of the life support device or system, or to affect its safety or effectiveness.