

AD845

FEATURES

Replaces Hybrid Amplifiers in Many Applications

AC PERFORMANCE:

Settles to 0.01% in 350 ns

100 V/ μ s Slew Rate

12.8 MHz min Unity-Gain Bandwidth

1.75 MHz Full-Power Bandwidth at 20 V p-p

DC PERFORMANCE:

0.25 mV max Input Offset Voltage

5 μ V/ $^{\circ}$ C max Offset Voltage Drift

0.5 nA Input Bias Current

250 V/mV min Open-Loop Gain

4 μ V p-p max Voltage Noise, 0.1 Hz to 10 Hz

94 dB min CMRR

Available in Plastic Mini-DIP, Hermetic Cerdip and SOIC Packages. Also Available in Tape and Reel in Accordance with EIA-481A Standard

PRODUCT DESCRIPTION

The AD845 is a fast, precise, N channel JFET input, monolithic operational amplifier. It is fabricated using Analog Devices' complementary bipolar (CB) process. Advanced laser-wafer trimming technology enables the very low input offset voltage and offset voltage drift performance to be realized. This precision, when coupled with a slew rate of 100 V/ μ s, a stable unity-gain bandwidth of 16 MHz, and a settling time of 350 ns 0.01%—while driving a parallel load of 100 pF and 500 Ω —represents a combination of features unmatched by any FET input IC amplifier. The AD845 can easily be used to upgrade many existing designs which use BiFET or FET input hybrid amplifiers and, in some cases, those which use bipolar input op amps.

The AD845 is ideal for use in applications such as active filters, high speed integrators, photo diode preamps, sample-and-hold amplifiers, log amplifiers, and in buffering A/D and D/A converters. The 250 μ V max input offset voltage makes offset nulling unnecessary in many applications. The common-mode rejection ratio of 110 dB over a ± 10 V input voltage range represents exceptional performance for a JFET input high speed op amp. This, together with a minimum open-loop gain of 250 V/mV ensures that 12-bit performance is achieved, even in unity-gain buffer circuits.

REV. D

Information furnished by Analog Devices is believed to be accurate and reliable. However, no responsibility is assumed by Analog Devices for its use, nor for any infringements of patents or other rights of third parties which may result from its use. No license is granted by implication or otherwise under any patent or patent rights of Analog Devices.

CONNECTION DIAGRAMS

Plastic Mini-DIP (N) Package
and Cerdip (Q) Package

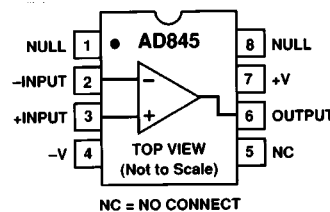

16-Pin SOIC
(R-16) Package

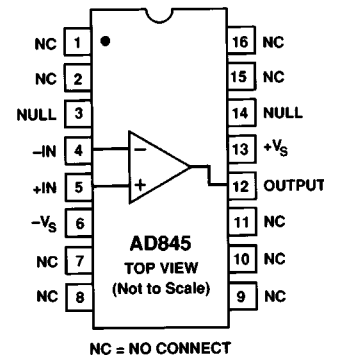

The AD845 conforms to the standard op amp pinout except that offset nulling is to V+. The AD845J and AD845K grade devices are available specified to operate over the commercial 0 $^{\circ}$ C to +70 $^{\circ}$ C temperature range. AD845A and AD845B devices are specified for operation over the -40 $^{\circ}$ C to +85 $^{\circ}$ C industrial temperature range. The AD845S is specified to operate over the full military temperature range of -55 $^{\circ}$ C to +125 $^{\circ}$ C. Both the industrial and military versions are available in 8-pin cerdip packages. The commercial version is available in an 8-pin plastic mini-DIP and 16-pin SOIC; "J" and "S" grade chips are also available.

PRODUCT HIGHLIGHTS

1. The high slew rate, fast settling time, and dc precision of the AD845 make it ideal for high speed applications requiring 12-bit accuracy.
2. The performance of circuits using the LF400, HA2520/2/5, HA2620/2/5, 3550, OPA605, and LH0062 can be upgraded in most cases.
3. The AD845 is unity-gain stable and internally compensated.
4. The AD845 is specified while driving 100 pF/500 Ω loads.

AD845–SPECIFICATIONS (@ +25°C and ±15 V dc, unless otherwise noted)

Model	Conditions	AD845J/A			AD845K/B			AD845S			Units
		Min	Typ	Max	Min	Typ	Max	Min	Typ	Max	
INPUT OFFSET VOLTAGE ¹											
Initial Offset	$T_{MIN}-T_{MAX}$		0.7	1.5		0.1	0.25		0.25	1.0	mV
Offset Drift					2.5			0.4			2.0
				20		1.5	5.0			10	$\mu\text{V}/^\circ\text{C}$
INPUT BIAS CURRENT ²											
Initial	$V_{CM} = 0\text{ V}$ $T_{MIN}-T_{MAX}$		0.75	2		0.5	1		0.75	2	nA
				45/75			18/38			500	nA
INPUT OFFSET CURRENT											
Initial	$V_{CM} = 0\text{ V}$ $T_{MIN}-T_{MAX}$		25	300		15	100		25	300	pA
				3/6.5			1.2/2.6			20	nA
INPUT CHARACTERISTICS											
Input Resistance				10^{11}		10^{11}			10^{11}		k Ω
Input Capacitance				4.0		4.0			4.0		pF
INPUT VOLTAGE RANGE											
Differential				± 20		± 20			± 20		V
Common Mode			± 10	+10.5/-13		± 10	+10.5/-13		± 10	+10.5/-13	V
Common-Mode Rejection	$V_{CM} = \pm 10\text{ V}$	86	110		94	113		86	110		dB
INPUT VOLTAGE NOISE	0.1 Hz to 10 Hz		4			4			4		$\mu\text{V p-p}$
	f = 10 Hz		80			80			80		$\text{nV}/\sqrt{\text{Hz}}$
	f = 100 Hz		60			60			60		$\text{nV}/\sqrt{\text{Hz}}$
	f = 1 kHz		25			25			25		$\text{nV}/\sqrt{\text{Hz}}$
	f = 10 kHz		18			18			18		$\text{nV}/\sqrt{\text{Hz}}$
	f = 100 kHz		12			12			12		$\text{nV}/\sqrt{\text{Hz}}$
INPUT CURRENT NOISE	f = 1 kHz		0.1			0.1			0.1		$\text{pA}/\sqrt{\text{Hz}}$
OPEN-LOOP GAIN	$V_O = \pm 10\text{ V}$ $R_{LOAD} \geq 2\text{ k}\Omega$ $R_{LOAD} \geq 500\ \Omega$ $T_{MIN}-T_{MAX}$	200	500		250	500		200	500		V/mV
		100	250		125	250		100	250		V/mV
		70			75			50			V/mV
OUTPUT CHARACTERISTICS											
Voltage	$R_{LOAD} \geq 500\ \Omega$	± 12.5			± 12.5			± 12.5			V
Current	Short Circuit		50			50			50		mA
Output Resistance	Open Loop		5			5			5		Ω
FREQUENCY RESPONSE											
Small Signal	Unity Gain	12.8	16		13.6	16		13.6	16		MHz
Full Power Bandwidth ³	$V_O = \pm 10\text{ V}$ $R_{LOAD} = 500\ \Omega$		1.75			1.75			1.75		MHz
Rise Time			20			20			20		ns
Overshoot			20			20			20		%
Slew Rate		80	100		94	100		94	100		V/ μs
Settling Time	10 V Step $C_{LOAD} = 100\text{ pF}$ $R_{LOAD} = 500\ \Omega$ to 0.01% to 0.1%		350			350	500		350	500	ns
			250			250			250		ns
DIFFERENTIAL GAIN	f = 4.4 MHz		0.04			0.04			0.04		%
DIFFERENTIAL PHASE	f = 4.4 MHz		0.02			0.02			0.02		Degree
POWER SUPPLY											
Rated Performance			± 15			± 15			± 15		V
Operating Range		± 4.75		± 18	± 4.75		± 18	± 4.75		± 18	V
Rejection Ratio	$V_S = \pm 5\text{ to } \pm 15\text{ V}$	88	110		95	113		88	110		dB
Quiescent Current	$T_{MIN}\text{ to }T_{MAX}$		10	12		10	12		10	12	mA

NOTES

¹Input offset voltage specifications are guaranteed after 5 minutes of operation at $T_A = +25^\circ\text{C}$.

²Bias current specifications are guaranteed maximum at either input after 5 minutes of operation at $T_A = +25^\circ\text{C}$.

³FPBW = slew rate/ 2π V peak.

⁴"S" grade $T_{MIN}-T_{MAX}$ are tested with automatic test equipment at $T_A = -55^\circ\text{C}$ and $T_A = +125^\circ\text{C}$.

All min and max specifications are guaranteed. Specifications shown in **boldface** are tested on all production units at final electrical test. Results from these tests are used to calculate outgoing quality levels.

Specifications subject to change without notice.

ABSOLUTE MAXIMUM RATINGS¹

Supply Voltage ±18 V

Internal Power Dissipation²

 Plastic Mini-DIP 1.6 Watts

 Cerdip 1.4 Watts

 16-Pin SOIC 1.5 Watts

Input Voltage +V_S

Output Short-Circuit Duration Indefinite

Differential Input Voltage +V_S and -V_S

Storage Temperature Range

 Q -65°C to +150°C

 N, R -65°C to +125°C

Lead Temperature Range (Soldering 60 sec) +300°C

NOTES

¹Stresses above those listed under "Absolute Maximum Ratings" may cause permanent damage to the device. This is a stress rating only, and functional operation of the device at these or any other conditions above those indicated in the operational sections of this specification is not implied. Exposure to absolute maximum rating conditions for extended periods may affect device reliability.

²Mini-DIP package: θ_{JA} = 100°C/watt; cerdip package: θ_{JA} = 110°C/watt. SOIC package: θ_{JA} = 100°C/W.

METALIZATION PHOTOGRAPH

Dimensions shown in inches and (mm).
Contact factory for latest dimensions.

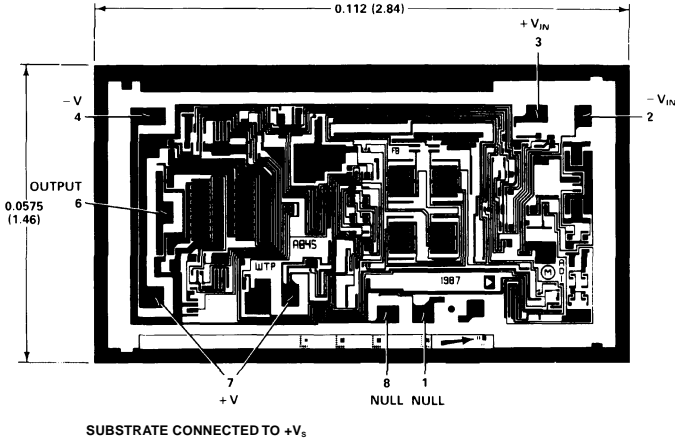

ORDERING GUIDE

Model	Temperature Range	Package Description	Package Option*
AD845JN	0°C to +70°C	8-Pin Plastic Mini-DIP	N-8
AD845KN	0°C to +70°C	8-Pin Plastic Mini-DIP	N-8
AD845JR-16	0°C to +70°C	16-Pin SOIC	R-16
AD845AQ	-40°C to +85°C	8-Pin Cerdip	Q-8
AD845BQ	-40°C to +85°C	8-Pin Cerdip	Q-8
AD845SQ	-55°C to +125°C	8-Pin Cerdip	Q-8
AD845SQ/883B	-55°C to +125°C	8-Pin Cerdip	Q-8
5962-8964501PA	-55°C to +125°C	8-Pin Cerdip	Q-8
AD845JCHIPS	0°C to +70°C	Die	
AD845SCHIPS	-55°C to +125°C	Die	
AD845JR-16-REEL	0°C to +70°C	Tape & Reel	
AD845JR-16-REEL7	0°C to +70°C	Tape & Reel	

AD845-Typical Characteristics

*N = Plastic DIP; Q = Cerdip; R = Small Outline IC (SOIC).

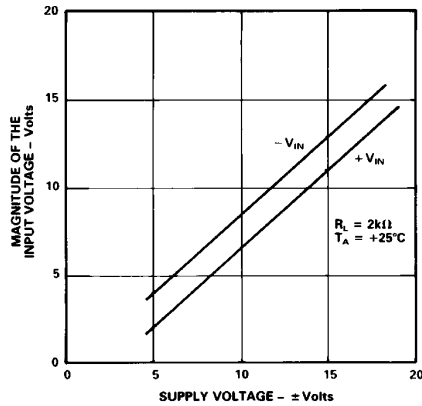

Figure 1. Input Voltage Swing vs. Supply Voltage

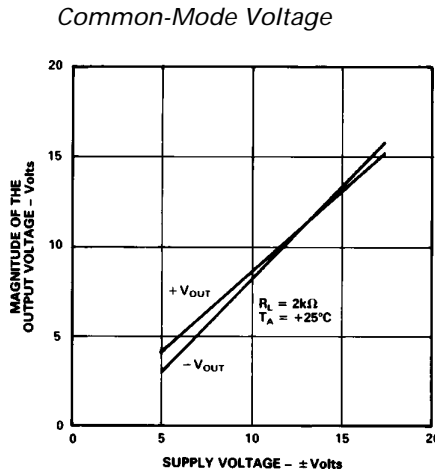

Figure 2. Output Voltage Swing vs. Supply Voltage

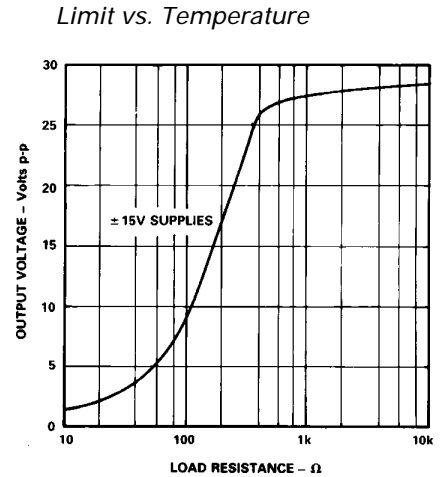

Figure 3. Output Voltage Swing vs. Resistive Load

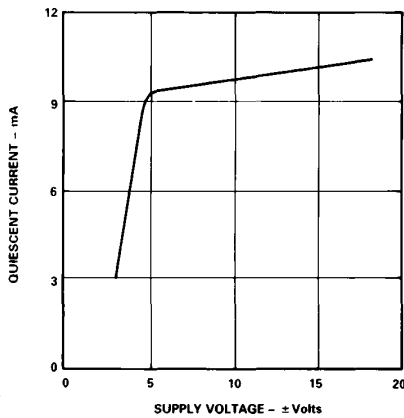

Figure 4. Quiescent Current vs. Supply Voltage

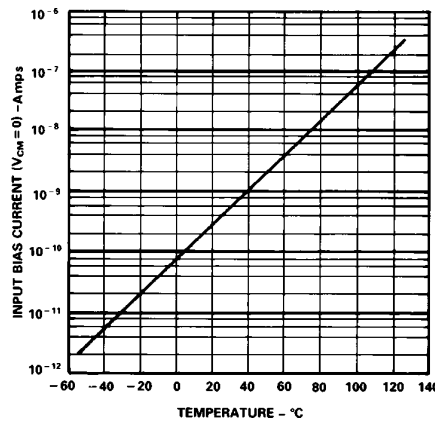

Figure 5. Input Bias Current vs. Temperature

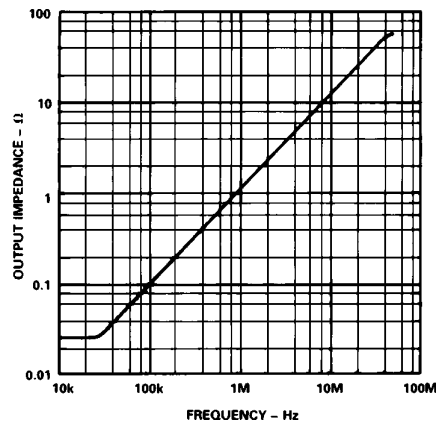

Figure 6. Magnitude of Output Impedance vs. Frequency

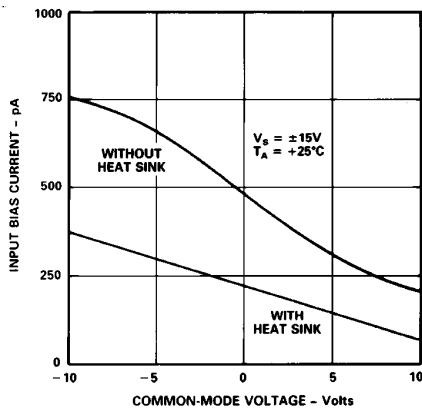

Figure 7. Input Bias Current vs. Common-Mode Voltage

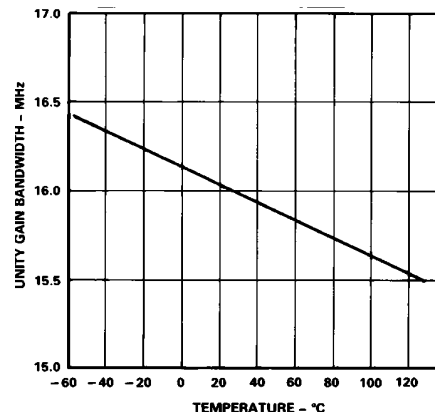

Figure 8. Short-Circuit Current vs. Temperature

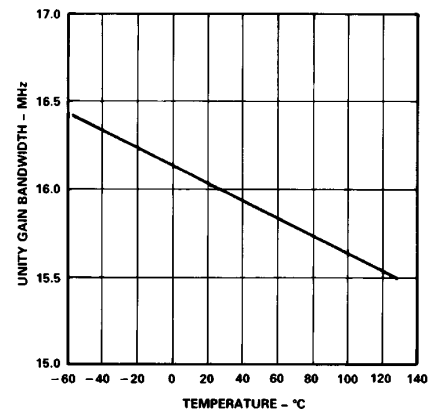

Figure 9. Unity-Gain Bandwidth vs. Temperature

vs. Temperature

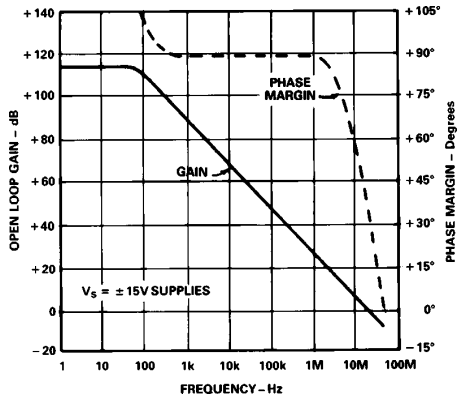

Figure 10. Open-Loop Gain and Phase Margin vs. Frequency

vs. Frequency

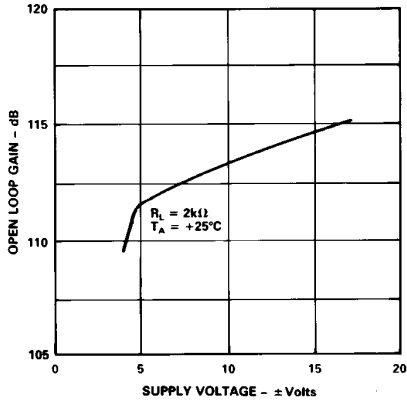

Figure 11. Open-Loop Gain vs. Supply Voltage

Spectral Density

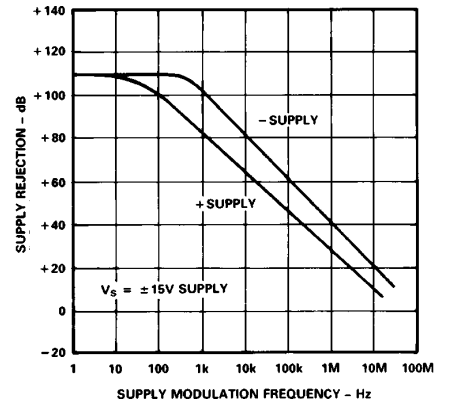

Figure 12. Power Supply Rejection vs. Frequency

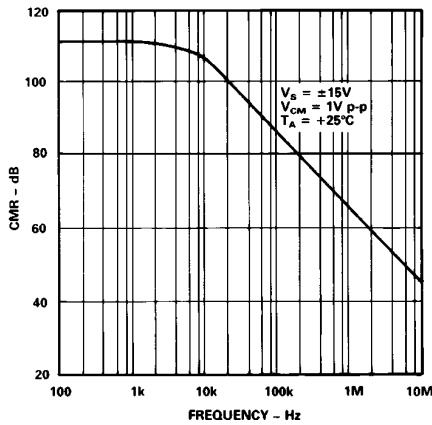

Figure 13. Common-Mode Rejection vs. Frequency

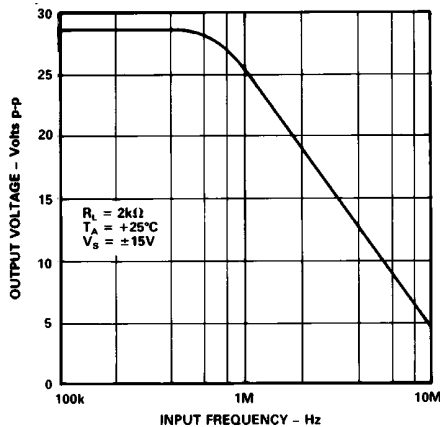

Figure 14. Large Signal Frequency Response

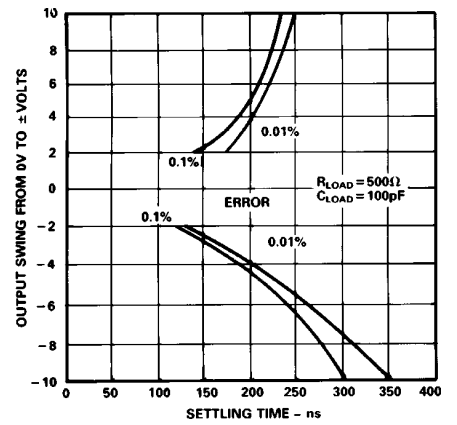

Figure 15. Output Swing and Error vs. Settling Time

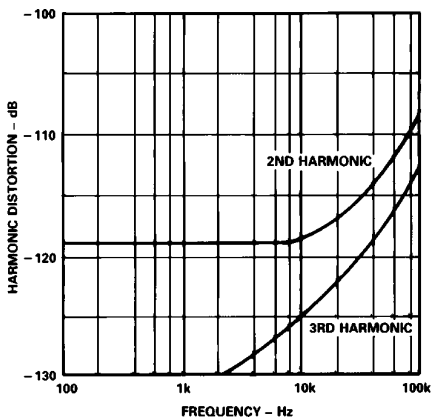

Figure 16. Harmonic Distortion

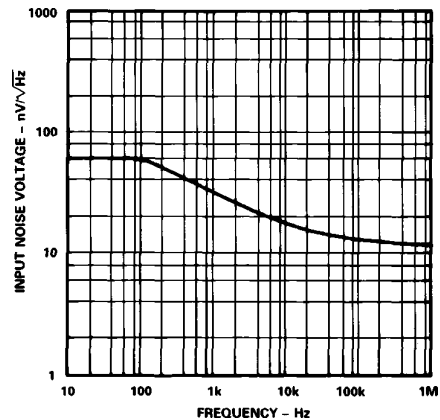

Figure 17. Input Noise Voltage

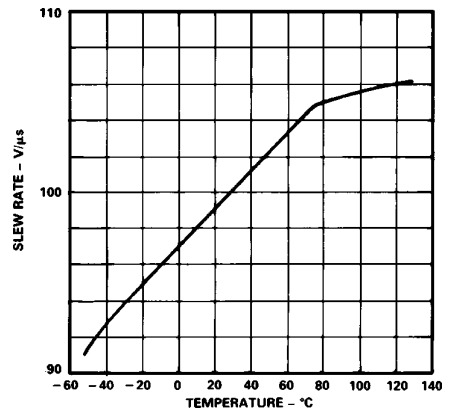

Figure 18. Slew Rate vs. Temperature

AD845

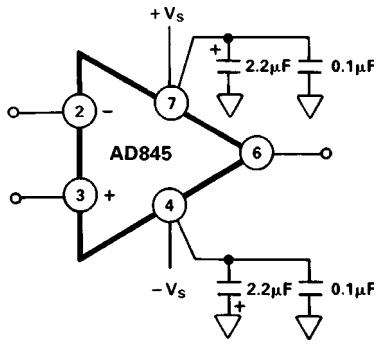

Figure 19. Recommended Power Supply Bypassing

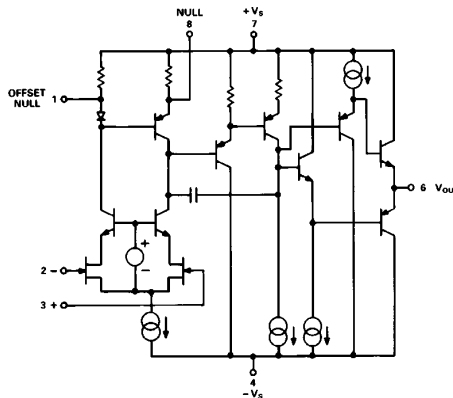

Figure 20. AD845 Simplified Schematic

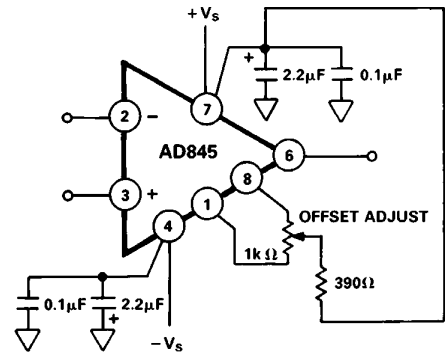

Figure 21. Offset Null Configuration

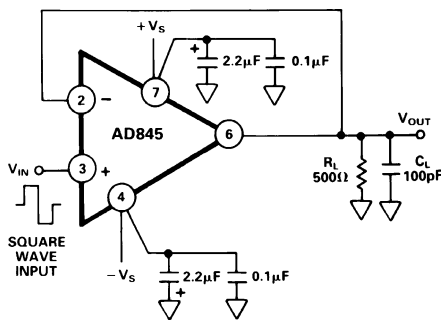

Figure 22a. Unity-Gain Follower

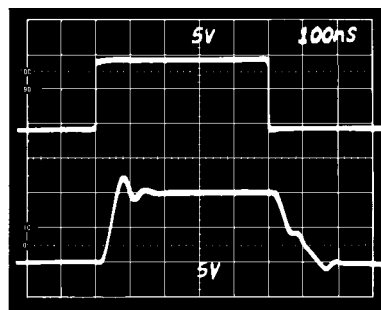

Figure 22b. Unity-Gain Follower Large Signal Pulse Response

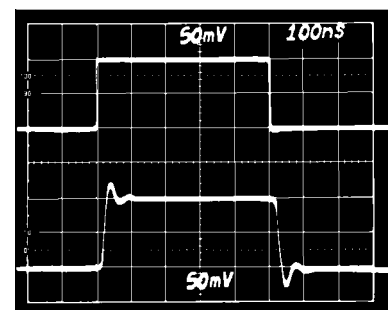

Figure 22c. Unity-Gain Follower Small Signal Pulse Response

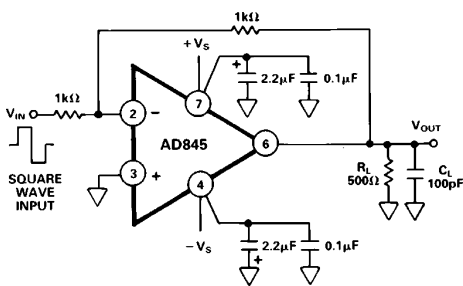

Figure 23a. Unity-Gain Inverter

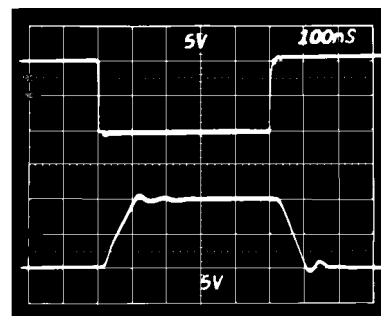

Figure 23b. Unity-Gain Inverter Large Signal Pulse Response

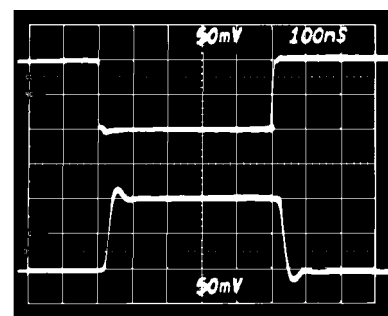

Figure 23c. Unity-Gain Inverter Small Signal Pulse Response

MEASURING AD845 SETTling TIME

The Figure 24 shows the AD845 settling time performance. This measurement was accomplished by driving the amplifier in the unity-gain inverting mode with a fast pulse generator. The input summing junction was measured using false nulling techniques.

Settling time is defined as:

The interval of time from the application of an ideal step function input until the closed-loop amplifier output has entered and remains within a specified error band.

Components of settling time include:

1. Propagation time through the amplifier
2. Slewing time to approach the final output value
3. Recovery time from overload associated with the slewing
4. Linear settling to within a specified error band.

These individual components can easily be seen in Figure 24. Settling time is extremely important in high speed applications where the current output of a DAC must be converted to a voltage. When driving a 500 Ω load in parallel with a 100 pF capacitor, the AD845 settles to 0.1% in 250 ns and to 0.01% in 310 ns.

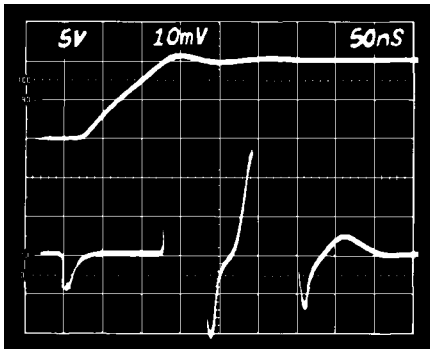

Figure 24. Settling Characteristics 0 V to 10 V Step
Upper Trace: Output of AD845 Under Test (5 V/Div)
Lower Trace: Error Voltage (1 mV/Div)

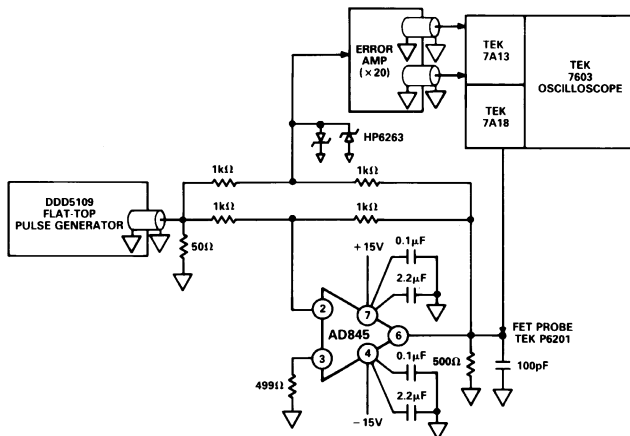

Figure 25. Settling Time Test Circuit

A HIGH SPEED INSTRUMENTATION AMP

The three op amp instrumentation amplifier circuit shown in Figure 26 can provide a range of gains from unity up to 1000 and higher. The instrumentation amplifier configuration features high common-mode rejection, balanced differential inputs

and stable, accurately defined gain. Low input bias currents and fast settling are achieved with the FET input AD845.

Most monolithic instrumentation amplifiers do not have the high frequency performance of the circuit in Figure 26. The circuit bandwidth is 10.9 MHz at a gain of 1 and 8.8 MHz at a gain of 10; settling time for the entire circuit is 900 ns to 0.01% for a 10 V step (Gain = 10).

The capacitors employed in this circuit greatly improve the amplifier's settling time and phase margin.

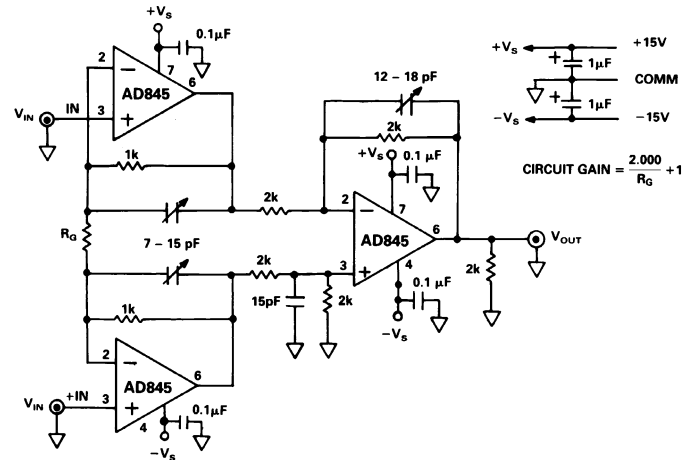

Figure 26. High Performance, High Speed Instrumentation Amplifier

Table I. Performance Summary for the Three Op Amp Instrumentation Amplifier Circuit

3 Op-Amp In-Amp			
Gain	R _G	Small Signal Bandwidth	Settling Time to 0.01%
1	Open	10.9 MHz	500 ns
2	2k	8.8 MHz	500 ns
10	226 Ω	2.6 MHz	900 ns
100	20 Ω	290 kHz	7.5 μs

Note: Resistors around the amplifiers' input pins need to be small enough in value so that the RC time constant they form, with stray circuit capacitance, does not reduce circuit bandwidth.

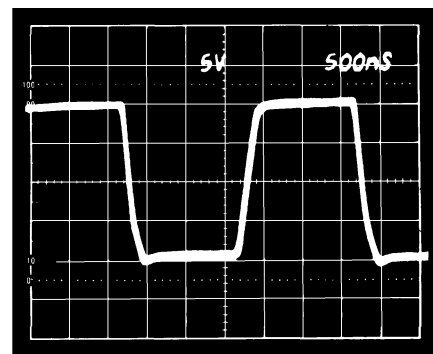

Figure 27. The Pulse Response of the Three Op Amp Instrumentation Amplifier. Gain = 1, Horizontal Scale: 0.5 ms/Div; Vertical Scale: 5 V/Div

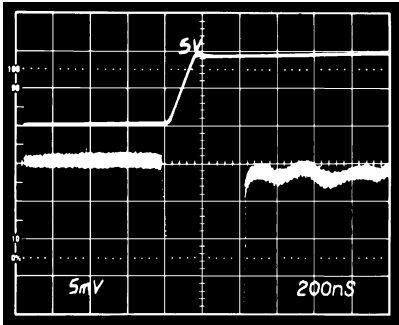

Figure 28a. Settling Time of the Three Op Amp Instrumentation Amplifier. Horizontal Scale: 200 ns/Div; Vertical Scale, Positive Pulse Input: 5 V/Div; Output Settling: 1 mV/Div

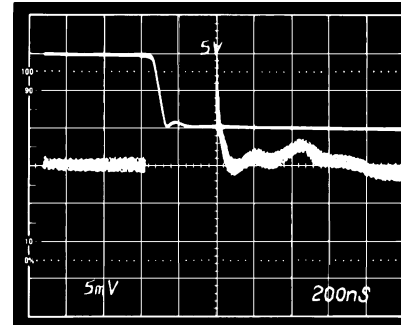

Figure 28b. Settling Time of the Three Op Amp Instrumentation Amplifier. Horizontal Scale: 200 ns/Div; Vertical Scale, Negative Pulse Input: 5 V/Div; Output Settling: 1 mV/Div

DRIVING THE ANALOG INPUT OF AN A/D CONVERTER

An op amp driving the analog input of an A/D converter, such as that shown in Figure 29, must be capable of maintaining a constant output voltage under dynamically changing load conditions. In successive approximation converters, the input current is compared to a series of switched trial currents. The comparison point is diode clamped but may deviate several hundred millivolts resulting in high frequency modulation of A/D input current. The output impedance of a feedback amplifier is made artificially low by the loop gain. At high frequencies, where the loop gain is low, the amplifier output impedance can approach its open-loop value. Most IC amplifiers exhibit a minimum open-loop output impedance of 25 Ω due to current limiting resistors. A few hundred microamps reflected from the change in converter loading can introduce errors in instantaneous input voltage. If the A/D conversion speed is not excessive and the bandwidth of the amplifier is sufficient, the amplifier's output will return to the nominal value before the converter makes its comparison. However, many amplifiers have relatively narrow bandwidth yielding slow recovery from output transients. The

AD845 is ideally suited to drive high resolution A/D converters with 5 μs on longer conversion times since it offers both wide bandwidth and high open-loop gain.

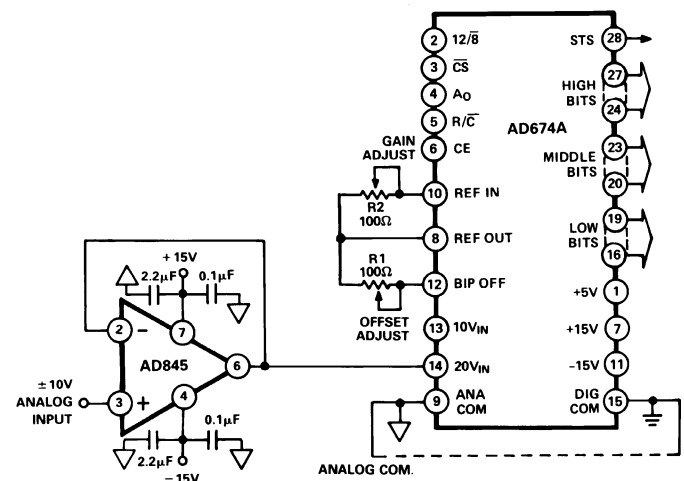
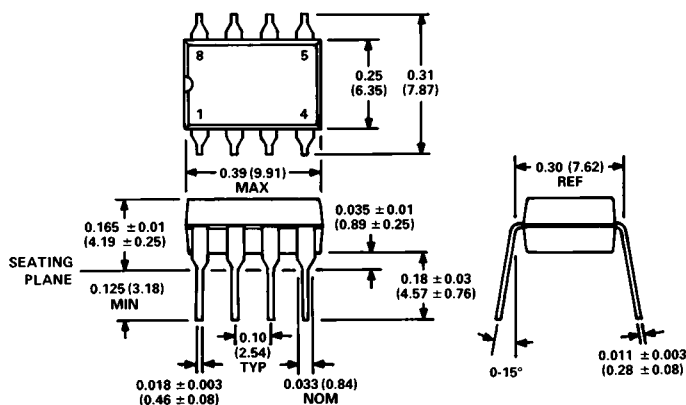

Figure 29. AD845 As ADC Unity Gain Buffer

OUTLINE DIMENSIONS

Dimensions shown in inches and (mm).

Mini-DIP (N) Package



Cerdip (Q) Package

