

TOSHIBA HALL SENSOR GaAs ION IMPLANTED PLANAR TYPE

# THS124

HIGH STABILITY MOTOR CONTROL.

DIGITAL TACHOMETER.

CRANK SHAFT POSITION SENSOR.

- Excellent Temperature Characteristics.
- Wide Operating Temperature Range. (; -55~125°C)
- Excellent Output Voltage Linearity.
- High Internal Resistance. :  $R_d = 1000\Omega$  (Min.)
- Low Residual Voltage Ratio. :  $V_{HO} / V_H = \pm 5\%$  (Max.)

MAXIMUM RATINGS (Ta = 25°C)

CHARACTERISTIC	SYMBOL	RATING	UNIT
Control Voltage	$V_C$	12	V
Power Dissipation	$P_D$	150	mW
Operating Temperature Range	$T_{opr}$	-55~125	°C
Storage Temperature Range	$T_{stg}$	-55~150	°C

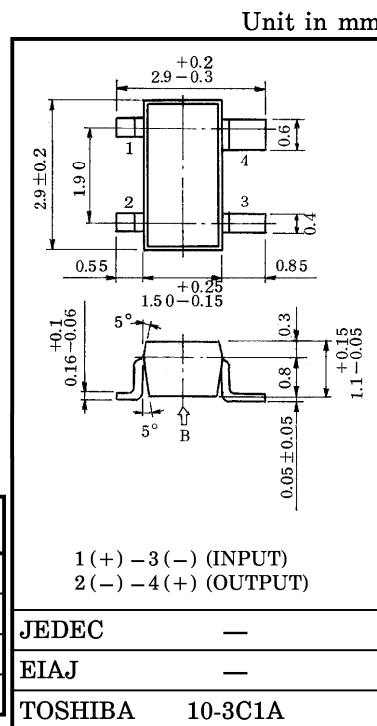

Weight : 0.013g

ELECTRICAL CHARACTERISTICS (Ta = 25°C)

CHARACTERISTIC	SYMBOL	TEST CONDITION	MIN.	TYP.	MAX.	UNIT
Internal Resistance (Input)	$R_d$	$I_C = 1mA$	1000	1250	1500	$\Omega$
Residual Voltage Ratio	$V_{HO} / V_H$	$V_C = 5V, B = 0 / B = 0.1T$	—	—	$\pm 5$	%
Hall Voltage (Note 1)	$V_H$	$V_C = 5V, B = 0.1T$	130	150	170	mV
Temperature Coefficient (Note 2)	$V_{HT}$	$I_C = 5mA, B = 0.1T$ $T_1 = 25^\circ C, T_2 = 125^\circ C$	—	—	-0.06	% / °C
Linearity (Note 3)	$\Delta K_H$	$V_C = 5V, B_1 = 0.05T, B_2 = 0.1T$	—	—	2	%
Specific Sensitivity (Note 4)	$K^*$	$V_C = 5V, B = 0.1T$	—	30	—	$\times 10^{-2} / T$
Internal Resistance (Output)	$R_{OUT}$	$I_C = 1mA$	1800	2375	3000	$\Omega$

Note 1 :  $V_H = V_{HM} - V_{HO}$  ( $V_{HM}$  is meter indication)

Note 2 :  $V_{HT} = \frac{1}{V_H(T_1)} \cdot \frac{V_H(T_2) - V_H(T_1)}{T_2 - T_1} \times 100$  (% / °C)  $V_{HO}$  : Residual Voltage

Note 3 :  $\Delta K_H = \frac{K_H(B_2) - K_H(B_1)}{1/2 \{ K_H(B_1) + K_H(B_2) \}} \times 100$  (%),  $K_H = \frac{V_H}{I_C \cdot B}$   $K_H$  : Product Sensitivity

Note 4 :  $K^* = V_H / (R_d \times I_C \times B) = K_H / R_d$

961001EAA2

- TOSHIBA is continually working to improve the quality and the reliability of its products. Nevertheless, semiconductor devices in general can malfunction or fail due to their inherent electrical sensitivity and vulnerability to physical stress. It is the responsibility of the buyer, when utilizing TOSHIBA products, to observe standards of safety, and to avoid situations in which a malfunction or failure of a TOSHIBA product could cause loss of human life, bodily injury or damage to property. In developing your designs, please ensure that TOSHIBA products are used within specified operating ranges as set forth in the most recent products specifications. Also, please keep in mind the precautions and conditions set forth in the TOSHIBA Semiconductor Reliability Handbook.
- The information contained herein is presented only as a guide for the applications of our products. No responsibility is assumed by TOSHIBA CORPORATION for any infringements of intellectual property or other rights of the third parties which may result from its use. No license is granted by implication or otherwise under any intellectual property or other rights of TOSHIBA CORPORATION or others.
- The information contained herein is subject to change without notice.

