

I<sup>2</sup> C-BUS COMPATIBLE REAL TIME CLOCK MODULE

# RTC-8583/8593 series

- Built-in crystal unit. Adjustment free with 10pF external capacitor.
- Small package (SOP 14-pin).
- Three mode operations: internal crystal oscillation, external 50 Hz clock and event counter.
- I<sup>2</sup>C-Bus interface compatible.
- Built-in 240 x 8 bit S-RAM available (RTC8583).
- Alarm and timer functions available.
- Wide operating voltage range 2.5V to 6.0V.
- Wide data hold voltage range 1.0V to 6.0V.
- Low current consumption (RTC8593, 1.0µA typical).

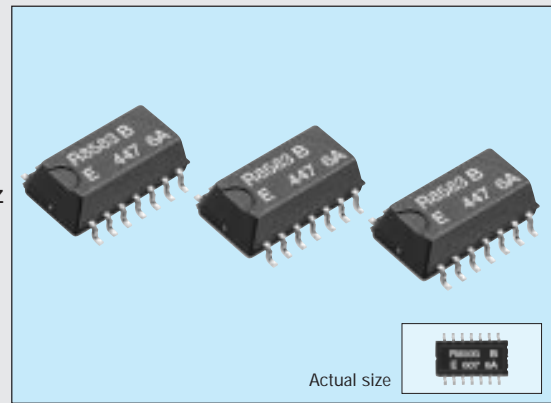

## Specifications (characteristics)

### Absolute Max. rating

Item	Symbol	Condition	Min.	Max.	Unit
Supply voltage	V <sub>DD</sub>	V <sub>DD</sub> -GND	-0.8	+7.0	V
Input voltage	V <sub>IN</sub>			V <sub>DD</sub> +0.8	
Input current	I <sub>I</sub>			10	mA
Output current	I <sub>O</sub>				
Storage temperature	T <sub>STG</sub>		-55	+125	°C

### Operating range

Item	Symbol	Condition	Min.	Max.	Unit
Operating voltage	V <sub>DD</sub>		2.5	6.0	V
Data holding voltage	V <sub>CLK</sub>		1.0		
Operating temperature	T <sub>OPR</sub>		-30	+70	°C
External capacitor	C <sub>G</sub>		10±5%		pF

### Frequency characteristics

Item	Symbol	Condition	Max.	Unit
Frequency tolerance	Δf/f <sub>0</sub>	T <sub>a</sub> =25°C, V <sub>DD</sub> =5V	A: 5±20 B: 5±50	ppm
Frequency temperature characteristics	T <sub>OP</sub>	T <sub>a</sub> =-10 to 70°C, V <sub>DD</sub> =5V	+10 -120	
Frequency voltage characteristics	f <sub>V</sub>	T <sub>a</sub> =25°C, V <sub>DD</sub> =2.0 to 6.0V	±3	
Oscillation start-up time	t <sub>OSC</sub>	T <sub>a</sub> =25°C, V <sub>DD</sub> =5V	3	s
Aging	f <sub>A</sub>	T <sub>a</sub> =25°C, V <sub>DD</sub> =5V first year	±5	ppm/year

### DC characteristics

Item	Symbol	Condition	Min.	Typ.	Max.	Unit	
"H" input voltage	V <sub>IH</sub>	—	0.7V <sub>DD</sub>		V <sub>DD</sub> +0.8	V	
"L" input voltage	V <sub>IL</sub>		-0.8		0.3		
"L" output current	I <sub>OL</sub>	V <sub>OL</sub> =0.4V	3			mA	
Input leak current					1	µA	
Leak current	I <sub>L</sub>	V <sub>IN</sub> =V <sub>DD</sub> or GND			250	nA	
Output current	I <sub>OL</sub>	V <sub>OL</sub> =0.4V	1			mA	
Leak current	I <sub>L</sub>	V <sub>IN</sub> =V <sub>DD</sub> or GND			1	µA	
Source current (access)	I <sub>DD0</sub>	f <sub>SCL</sub> =100 kHz			200	µA	
Current Consumption (non access)	8583	1	I <sub>DD1</sub>	V <sub>DD</sub> =5V, f <sub>SCL</sub> =0 Hz	10	50	µA
		2	I <sub>DD2</sub>	V <sub>DD</sub> =3V, f <sub>SCL</sub> =0 Hz	3.5	15	
		3	I <sub>DD3</sub>	V <sub>DD</sub> =2V, f <sub>SCL</sub> =0 Hz	2.0	10	
	8593	1	I <sub>DD1</sub>	V <sub>DD</sub> =5V, f <sub>SCL</sub> =0 Hz	3.0	15	
		2	I <sub>DD2</sub>	V <sub>DD</sub> =3V, f <sub>SCL</sub> =0 Hz	1.2	10	
		3	I <sub>DD3</sub>	V <sub>DD</sub> =2V, f <sub>SCL</sub> =0 Hz	1.0	8	

The I<sup>2</sup>C-Bus is a trademark of Philips Electronics N.V.

## Terminal connection

### RTC-8583/8593

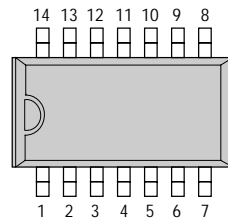

No.	8583	8593	8593SB
1	GND1	N.C	N.C
2	SCL	SCL	N.C
3	SDA	SDA	N.C
4	N.C	N.C	N.C
5	GND	GND	N.C
6	N.C	N.C	N.C
7	A0	RESET	N.C
8	OSC1	OSC1	RESET
9	N.C	N.C	GND
10	N.C	N.C	SDA
11	V <sub>DD</sub>	V <sub>DD</sub>	SCL
12	N.C	N.C	INT
13	N.C	N.C	V <sub>DD</sub>
14	INT	INT	OSC1
15			N.C
16			N.C
17			N.C
18			N.C

### RTC-8593SB

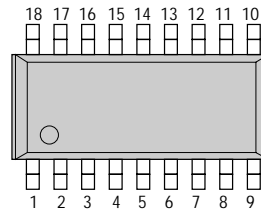

## External dimensions

(Unit: mm)

### RTC-8583/8593 (SOP 14-pin)

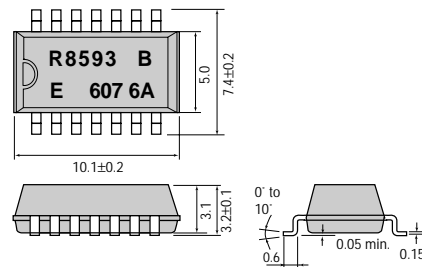

### RTC-8593SB (SOP 18-pin)

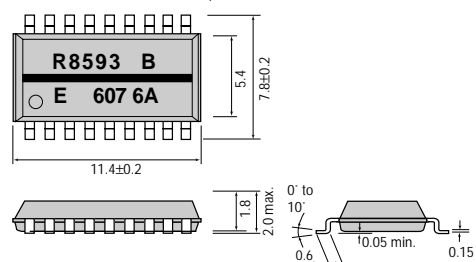

Register table

Address	Register name	count	bit 7	bit 6	bit 5	bit 4	bit 3	bit 2	bit 1	bit 0
00	CNT		STOP	HOLD	MODE1	MODE2	MASK	ALM	AF	TF
01	1/100SEC	0 to 99	8/10	4/10	2/10	1/10	8/100	4/100	2/100	1/100
02	SEC	0 to 59	10S8	10S4	10S2	10S1	S8	S4	S2	S1
03	MIN	0 to 59	10MIN8	10MIN4	10MIN2	10MIN1	MIN8	MIN4	MIN2	MIN1
04	HOUR	0 to 23	12/24	AM/PM	10HOUR2	10HOUR1	HOUR8	HOUR4	HOUR2	HOUR1
05	DAY	0 to 31	YEAR2	YEAR1	10DAY2	10DAY1	DAY8	DAY4	DAY2	DAY1
06	MONTH	0 to 12	W4	W2	W1	10MONTH1	MONTH8	MONTH4	MONTH2	MONTH1
07	TIMER	0 to 99	10TIMER8	10TIMER4	10TIMER2	10TIMER1	TIMER8	TIMER4	TIMER2	TIMER1
08	ALARM		AIE	TAIE	AS1	AS0	TIE	TCP2	TCP1	TCP0
09	A-1/100	0 to 99	A-8/10	A-4/10	A-2/10	A-1/10	A-8/100	A-4/100	A-2/100	A-1/100
0A	A-SEC	0 to 59	10A-SEC8	10A-SEC4	10A-SEC2	10A-SEC1	10A-SEC8	10A-SEC4	10A-SEC2	10A-SEC1
0B	A-MIN	0 to 59	10A-MIN8	10A-MIN4	10A-MIN2	10A-MIN1	10A-MIN8	10A-MIN4	10A-MIN2	10A-MIN1
0C	A-HR	0 to 23	A-12/24	A-AM/PM	10A-HR2	10A-HR1	A-HR8	A-HR4	A-HR2	A-HR1
0D	A-DAY	0 to 31	—		A-DAY2	A-DAY1	A-DAY8	A-DAY4	A-DAY2	A-DAY1
0E	A-MON	0 to 12	—			10A-MON1	10A-MON8	10A-MON4	10A-MON2	10A-MON1
0F	A-TIM	0 to 99	10A-TIM8	10A-TIM4	10A-TIM2	10A-TIM1	A-TIM8	A-TIM4	A-TIM2	A-TIM1
10 to FF		0 to FF	User's RAM (RTC-8583 is available)							

Switching characteristics

Item	Symbol	Min.	Max.	Unit	
SCL clock frequency	f <sub>SCL</sub>	—	100	KHz	
Spike tolerance on bus	t <sub>sw</sub>	—	100	ns	
Bus free time	t <sub>BUF</sub>	4.7	—	μs	
Start condition set-up time	t <sub>SU</sub> ; STA	4.0	—		
Hold time	t <sub>HD</sub> ; STA	4.0	—		
SCL "L" time	t <sub>LOW</sub>	4.7	—		
SCL "H" time	t <sub>HIGH</sub>	4.0	—		
SCL, SDA rise time	t <sub>RLH</sub>	—	1.0		
SCL, SDA fall time	t <sub>RHL</sub>	—	0.3		
Date set-up time	t <sub>SU</sub> ; DAT	250	—		ns
Date hold time	t <sub>HD</sub> ; DAT	0	—		
SCL low to data out valid	t <sub>VD</sub> ; DAT	—	3.4		μs
Stop condition set-up time	t <sub>SU</sub> ; STO	4.0	—		
Event counter frequency	f <sub>i</sub>	—	1.0	MHz	

Timing chart

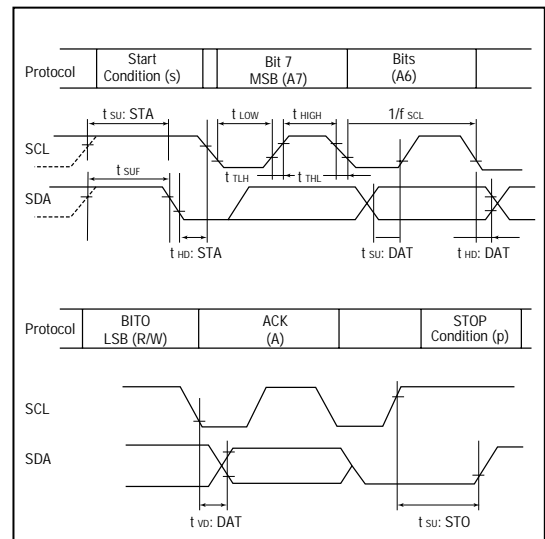

Block diagram

