

DUAL MONOSTABLE MULTIVIBRATOR

- RETRIGGERABLE/RESETTABLE CAPABILITY
- TRIGGER AND RESET PROPAGATION DELAYS INDEPENDENT OF R_X , C_X
- TRIGGERING FROM LEADING OR TRAILING EDGE
- Q AND \bar{Q} BUFFERED OUTPUTS AVAILABLE
- SEPARATE RESETS
- WIDE RANGE OF OUTPUT-PULSE WIDTHS
- QUIESCENT CURRENT SPECIFIED TO 20V FOR HCC DEVICE
- 5V, 10V, AND 15V PARAMETRIC RATINGS
- INPUT CURRENT OF 100nA AT 18V AND 25°C FOR HCC DEVICE
- 100% TESTED FOR QUIESCENT CURRENT
- MEETS ALL REQUIREMENTS OF JEDEC TENTATIVE STANDARD N° 13A, "STANDARD SPECIFICATIONS FOR DESCRIPTION OF "B" SERIES CMOS DEVICES"

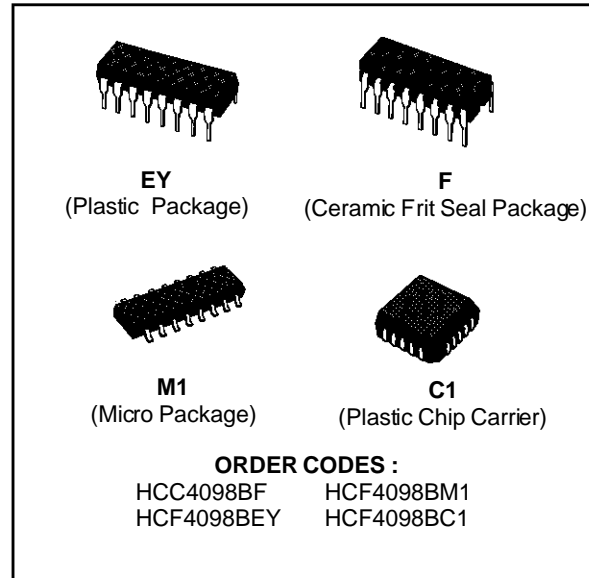

DESCRIPTION

The **HCC4098B** (extended temperature range) and **HCF4098B** (intermediate temperature range) are monolithic integrated circuit, available in 16-lead dual in-line plastic or ceramic package and plastic micropackage. The **HCC/HCF4098B** dual monostable multivibrator provides stable retriggerable/resettable one-shot operation for any fixed-voltage timing application. An external resistor (R_X) and an external capacitor (C_X) control the timing for the circuit. Adjustment of R_X and C_X provides a wide range of output pulse widths from the Q and \bar{Q} terminals. The time delay from trigger input to output transition (trigger propagation delay) and the time delay from reset input to output transition (reset propagation delay) are independent of R_X and C_X . Leading-edge-triggering (+ TR) and trailing-edge-triggering (- TR) inputs are provided for triggering from either edge of an input pulse. An unused + TR input should be tied to V_{SS} . An unused - TR input should be tied to V_{DD} . A RESET (on low level) is provided for immediate termination of the output pulse or to prevent output pulses when power is turned on. An unused RESET input should be tied to V_{DD} . However, if an entire section of the **4098B** is not used, its RESET should be tied to V_{SS} . See table I. In normal operation the circuit triggers (extends the output

PIN CONNECTIONS

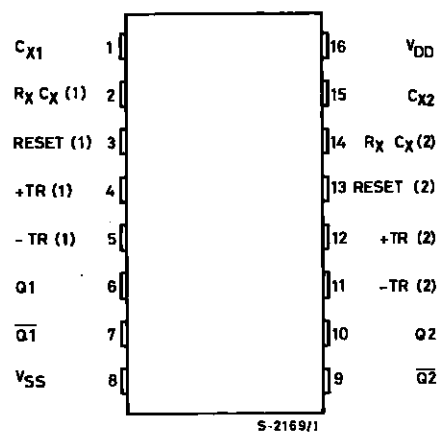

HCC/HCF4098B

pulse one period) on the application of each new trigger pulse. For operation in the non-triggerable mode, Q is connected to $-TR$ when leading-edge triggering (+ TR) is used or Q is connected to + TR when trailing-edge triggering ($-TR$) is used. The time period (T) for this multivibrator can be approximated by $T_X = 1/2 R_X C_X$ for $C_X \geq 0.01 \mu\text{F}$. Time periods as a function of R_X for values of C_X and V_{DD} are given in fig. 8. Values of T vary from unit to unit and as a function of voltage, temperature, and $R_X C_X$. The minimum value of external resistance, R_X , is 5 k Ω . The maxi-

imum value of external capacitance, C_X , is 100 μF . Fig.9 shows time periods as a function of C_X for values of R_X and V_{DD} . The output pulse width has variations of $\pm 2.5\%$ typically, over the temperature range of -55°C to 125°C for $C_X = 1000\text{pF}$ and $R_X = 100\text{k}\Omega$. For power supply variations of $\pm 5\%$, the output pulse width has variations of $\pm 0.5\%$ typically, for $V_{DD} = 10\text{V}$ and 15V and $\pm 1\%$ typically, for $V_{DD} = 5\text{V}$ at $C_X = 1000\text{pF}$ and $R_X = 5\text{k}\Omega$.

FUNCTIONAL DIAGRAM

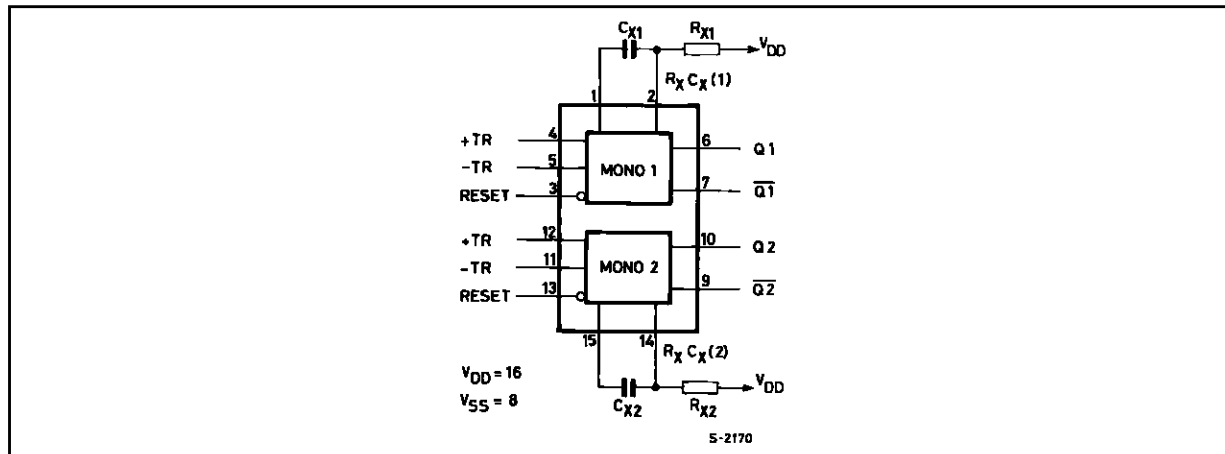

ABSOLUTE MAXIMUM RATINGS

Symbol	Parameter	Value	Unit
V_{DD}^*	Supply Voltage : HCC Types HCF Types	- 0.5 to + 20 - 0.5 to + 18	V
V_i	Input Voltage	- 0.5 to $V_{DD} + 0.5$	V
I_i	DC Input Current (any one input)	± 10	mA
P_{tot}	Total Power Dissipation (per package) Dissipation per Output Transistor for $T_{op} = \text{Full Package-temperature Range}$	200 100	mW
T_{op}	Operating Temperature : HCC Types HCF Types	- 55 to + 125 - 40 to + 85	$^\circ\text{C}$
T_{stg}	Storage Temperature	- 65 to + 150	$^\circ\text{C}$

Stresses above those listed under "Absolute Maximum Ratings" may cause permanent damage to the device. This is a stress rating only and functional operation of the device at these or any other conditions above those indicated in the operational sections of this specification is not implied. Exposure to absolute maximum rating conditions for external periods may affect device reliability.

* All voltage values are referred to V_{SS} pin voltage.

RECOMMENDED OPERATING CONDITIONS

Symbol	Parameter	Value	Unit
V_{DD}	Supply Voltage : HCC Types HCF Types	3 to 18 3 to 15	V
V_i	Input Voltage	0 to V_{DD}	V
T_{op}	Operating Temperature : HCC Types HCF Types	- 55 to + 125 - 40 to + 85	$^\circ\text{C}$

LOGIC DIAGRAMS

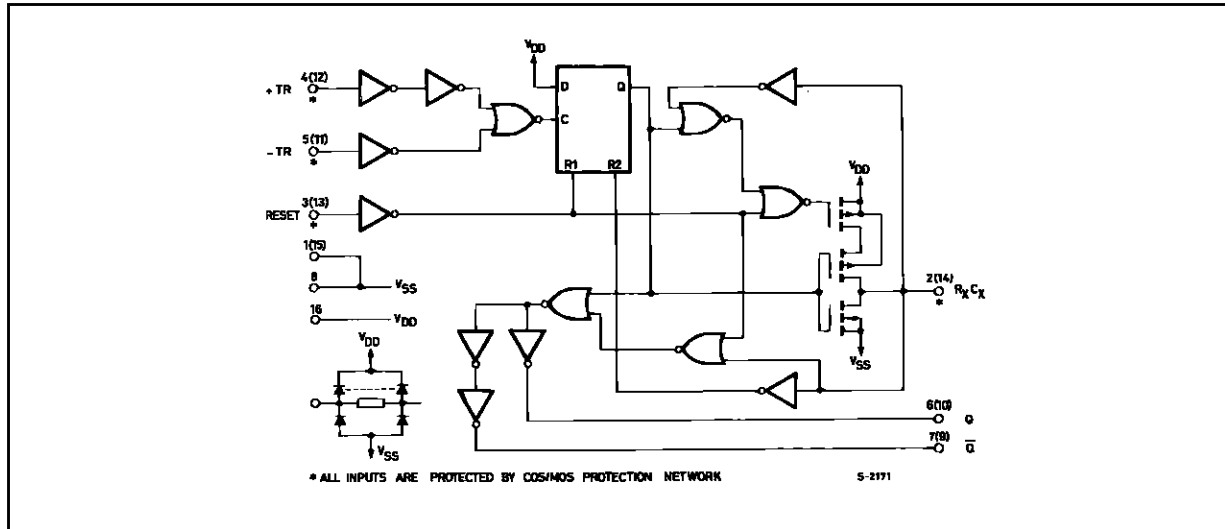
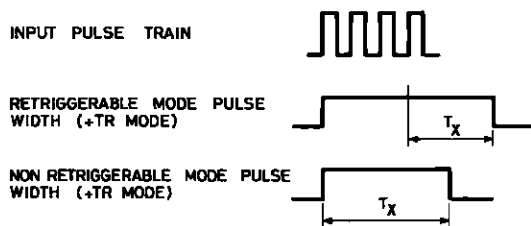

Table 1 : Functional Terminal Connections.

Function	Terminal Connections						Other Connections	
	to V _{DD}		to V _{SS}		Input Pulse to		Mono (1)	Mono (2)
	Mono (1)	Mono (2)	Mono (1)	Mono (2)	Mono (1)	Mono (2)		
Leading - Edge Trigger/Retriggerable	3,5	11,13			4	12		
Leading - Edge Trigger/Non - retriggerable	3	13			4	12	5,7	11,9
Trailing - Edge Trigger/Retriggerable	3	13	4	12	5	11		
Trailing - Edge Trigger/Non - retriggerable	3	13			5	11	4,6	12,10
Unused Section	5	11	3,4	12,13				

Notes : 1. A Retriggerable one-shot multivibrator has an output pulse width which is extended one full time period (T_x) after application of the last trigger pulse.

2. A non-retriggerable one-shot multivibrator has a time period T_x referenced from the application of the first trigger pulse.



5-2172

STATIC ELECTRICAL CHARACTERISTICS (over recommended operating conditions)

Symbol	Parameter		Test Conditions				Value						Unit	
			V _I (V)	V _O (V)	I _O (μ A)	V _{DD} (V)	T _{Low} *		25°C			T _{High} *		
							Min.	Max.	Min.	Typ.	Max.	Min.		Max.
I _L	Quiescent Current	HCC Types	0/ 5			5		1		0.02	1		30	μ A
			0/10			10		2		0.02	2		60	
			0/15			15		4		0.02	4		120	
		0/20			20		20		0.04	20		600		
		HCF Types	0/ 5			5		4		0.02	4		30	
			0/10			10		8		0.02	8		60	
0/15				15		16		0.02	16		120			
V _{OH}	Output High Voltage	0/ 5		< 1	5	4.95		4.95			4.95		V	
		0/10		< 1	10	9.95		9.95			9.95			
		0/15		< 1	15	14.95		14.95			14.95			
V _{OL}	Output Low Voltage	5/0		< 1	5		0.05			0.05		0.05	V	
		10/0		< 1	10		0.05			0.05		0.05		
		15/0		< 1	15		0.05			0.05		0.05		
V _{IH}	Input High Voltage		0.5/4.5	< 1	5	3.5		3.5			3.5		V	
			1/9	< 1	10	7		7			7			
			1.5/13.5	< 1	15	11		11			11			
V _{IL}	Input Low Voltage		4.5/0.5	< 1	5		1.5			1.5		1.5	V	
			9/1	< 1	10		3			3		3		
			13.5/1.5	< 1	15		4			4		4		
I _{OH}	Output Drive Current	HCC Types	0/ 5	2.5		5	- 2		- 1.6	- 3.2		- 1.15	mA	
			0/ 5	4.6		5	- 0.64		- 0.51	- 1		- 0.36		
			0/10	9.5		10	- 1.6		- 1.3	- 2.6		- 0.9		
		0/15	13.5		15	- 4.2		- 3.4	- 6.8		- 2.4			
		HCF Types	0/ 5	2.5		5	- 1.53		- 1.36	- 3.2		- 1.1		
			0/ 5	4.6		5	- 0.52		- 0.44	- 1		- 0.36		
0/10	9.5			10	- 1.3		- 1.1	- 2.6		- 0.9				
0/15	13.5		15	- 3.6		- 3.0	- 6.8		- 2.4					
I _{OL}	Output Sink Current	HCC Types	0/ 5	0.4		5	0.64		0.51	1		0.36	mA	
			0/10	0.5		10	1.6		1.3	2.6		0.9		
			0/15	1.5		15	4.2		3.4	6.8		2.4		
		HCF Types	0/ 5	0.4		5	0.52		0.44	1		0.36		
			0/10	0.5		10	1.3		1.1	2.6		0.9		
			0/15	1.5		15	3.6		3.0	6.8		2.4		
I _{IH} , I _{IL}	Input Leakage Current	HCC Types	0/18	Any Input	18		\pm 0.1		\pm 10 ⁻⁵	\pm 0.1		\pm 1	μ A	
		HCF Types	0/15		15		\pm 0.3		\pm 10 ⁻⁵	\pm 0.3		\pm 1		
C _I	Input Capacitance			Any Input					5	7.5			pF	

* T_{Low} = - 55°C for HCC device : - 40°C for HCF device.

* T_{High} = + 125°C for HCC device : + 85°C for HCF device.

The Noise Margin for both "1" and "0" level is : 1V min. with V_{DD} = 5V, 2V min. with V_{DD} = 10V, 2.5 V min. with V_{DD} = 15V.

DYNAMIC ELECTRICAL CHARACTERISTICS ($T_{amb} = 25^{\circ}\text{C}$, $C_L = 50\text{pF}$, $R_L = 200\text{k}\Omega$, typical temperature coefficient for all V_{DD} values is $0.3\%/^{\circ}\text{C}$, all input rise and fall times = 20ns)

Symbol	Parameter	Test Conditions			Value			Unit
		R_X (k Ω)	C_X (pF)	V_{DD} (V)	Min.	Typ.	Max.	
t_{PLH} , t_{PHL}	Trigger Propagation Delay Time (+ TR, - TR to Q, \bar{Q})	5 to 10.000	≥ 15	5		250	500	ns
				10		125	250	
				15		100	200	
t_{WH} , t_{WL}	Trigger Pulse Width	5 to 10.000	≥ 15	5	140	70		ns
				10	60	30		
				15	40	20		
t_{TLH}	Transition Time	5 to 10.000	≥ 15	5		100	200	
				10		50	100	
				15		40	80	
t_{THL}	Transition Time	5 to 10.000	15 to 10.000	5		100	200	ns
				10		50	100	
				15		40	80	
		5 to 10.000	0.01 μF to 0.1 μF	5		150	300	
				10		75	150	
				15		65	130	
		5 to 10.000	0.1 μF to 1 μF	5		250	500	
				10		150	300	
				15		80	160	
t_{PLH} , t_{PHL}	Propagation Delay Time (reset)	5 to 10.000	≥ 15	5		225	450	ns
				10		125	250	
				15		75	150	
t_{WR}	Pulse Width (reset)	100	15	5	200	100		ns
				10	80	40		
				15	60	30		
			1000	5	1200	600		
				10	600	300		
				15	500	250		
		0.1 μF	5	50	250		μs	
			10	30	15			
			15	20	10			
t_r , t_f (TR)	Rise or Fall Time (trigger)		5 to 15				100	μs
	Pulse Width Match Between Circuits in Same Package	10	10.000	5		5	10	%
				10		7.5	15	
				15		7.5	15	

Figure 2 : Typical Output Low (sink) Current Characteristics.

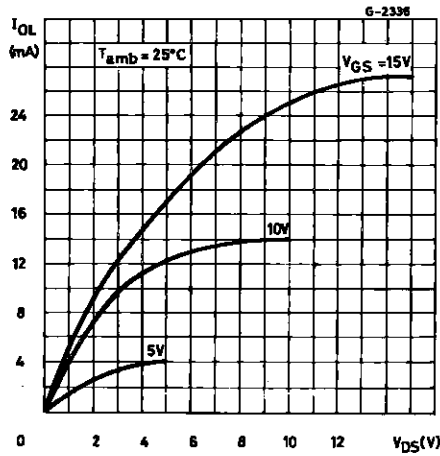

Figure 3 : Minimum Output Low (sink) Current Characteristics.

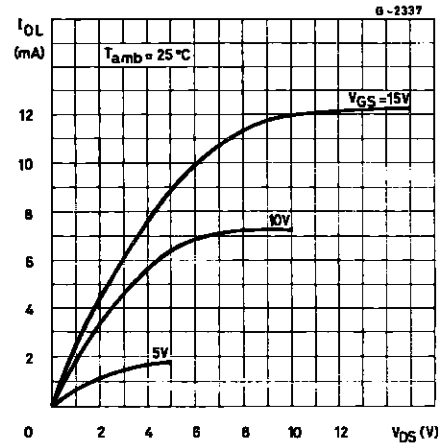

Figure 4 : Typical Output High (source) Current Characteristics.

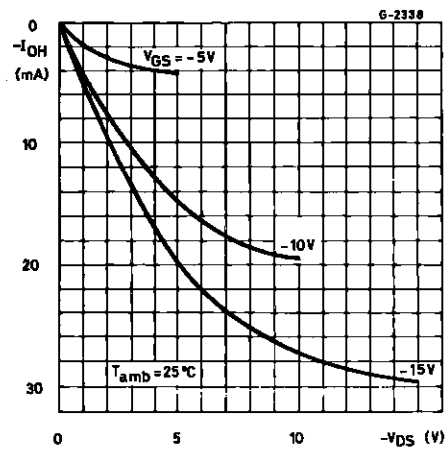

Figure 5 : Minimum Output High (source) Current Characteristics.

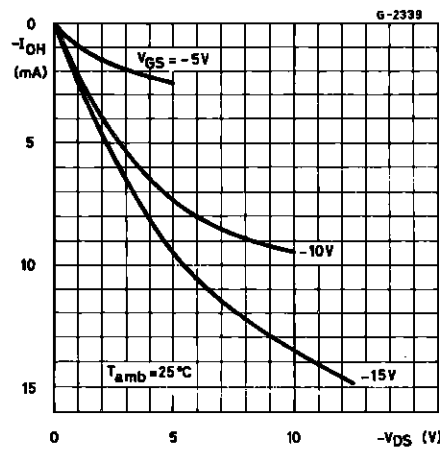

Figure 6 : Typical Propagation Delay Times vs. Load Capacitance, Trigger in to Q out. (All values of C_x and R_x).

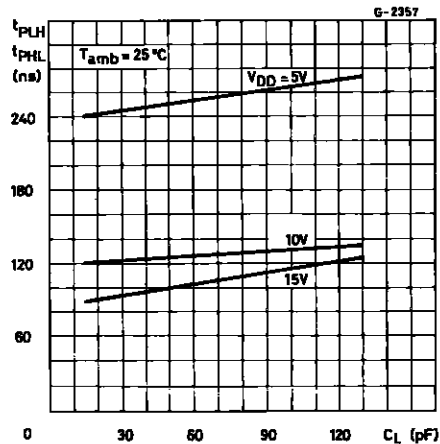

Figure 7 : Transition Time vs. Load Capacitance for $R_x = 5k\Omega$, $10000 k\Omega$ and $C_x = 15pF$, $10000pF$.

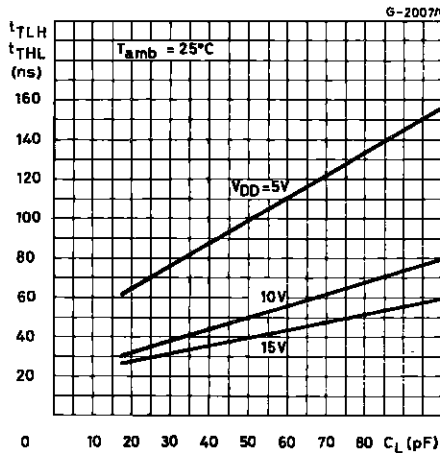

Figure 8 : Typical External Resistance vs. Pulse Width at Various V_{DD} and C_X .

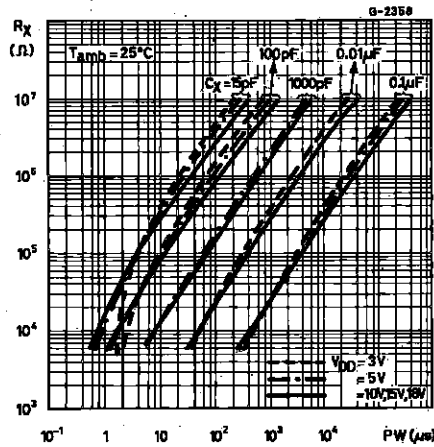

Figure 9 : Typical External Capacitance vs. Pulse Width at Various V_{DD} and R_X .

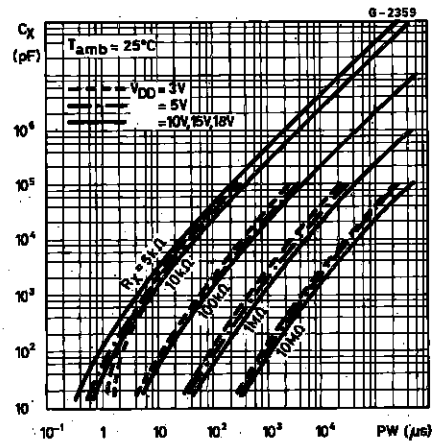

Figure 10 : Typical Minimum Reset Pulse Width vs. External Capacitance.

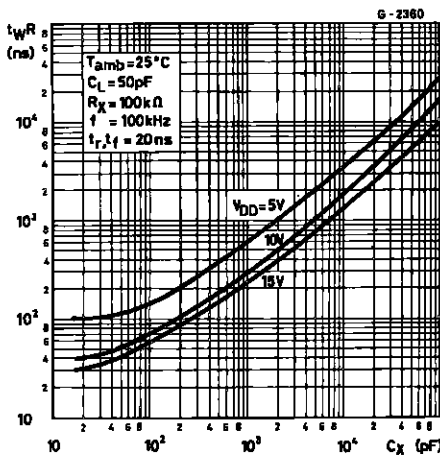
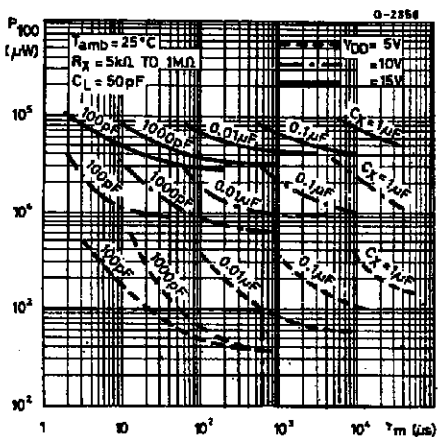

Figure 11 : Average Power Dissipation for 100% Duty Cycle vs. One-shot Pulse width.



To calculate average power dissipation (P) for less than 100% duty cycle :

P_{100} = average power for 100% duty cycle

$$P = \left(\frac{\tau_m}{\tau_T} \right) P_{100}$$

where τ_m = one-shot pulse width
 τ_T = trigger pulse period

e.g. : For $\tau_m = 600\text{ms}$ $\tau_T = 1000\text{ms}$,
 $C_X = 0.01\mu\text{F}$, $V_{DD} = 5\text{V}$

$$P = \left(\frac{600}{1000} \right) 103\mu\text{W} = 600\mu\text{W}$$

(see dotted line on graph)

5-2172

TEST CIRCUITS

Figure 12 : Quiescent -Device Current.

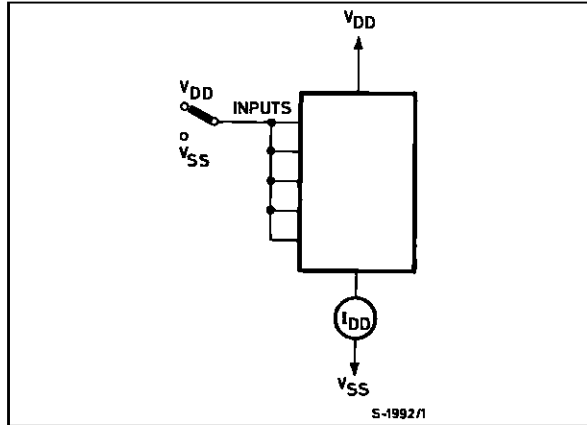

Figure 13 : Input-Voltage.

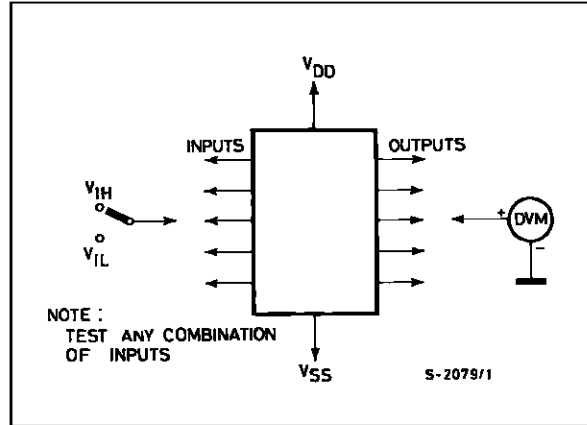
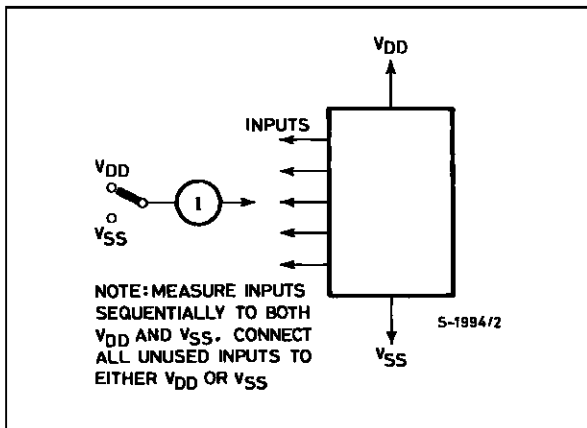

Figure 14 : Input Leakage.



TYPICAL APPLICATIONS

Figure 15 : Astable Multivibrator with Restart after Reset Capability.

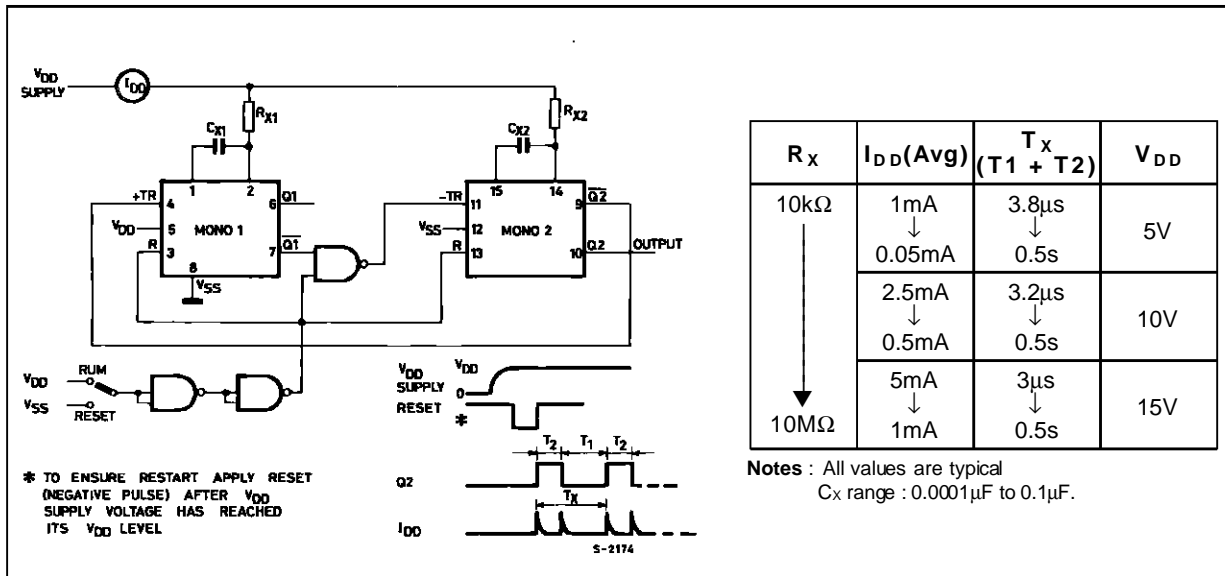
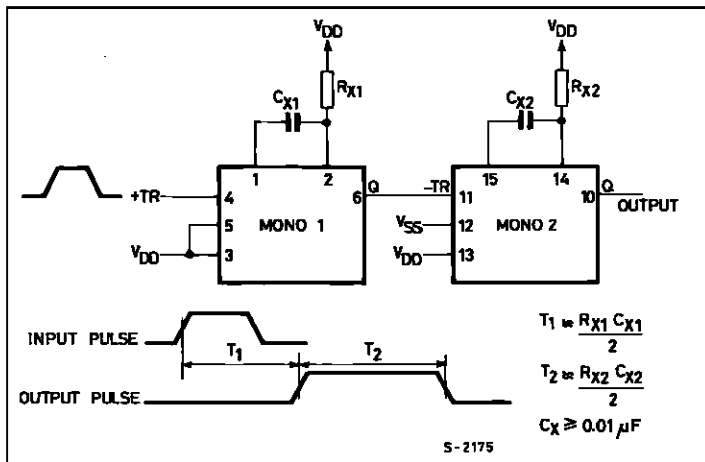
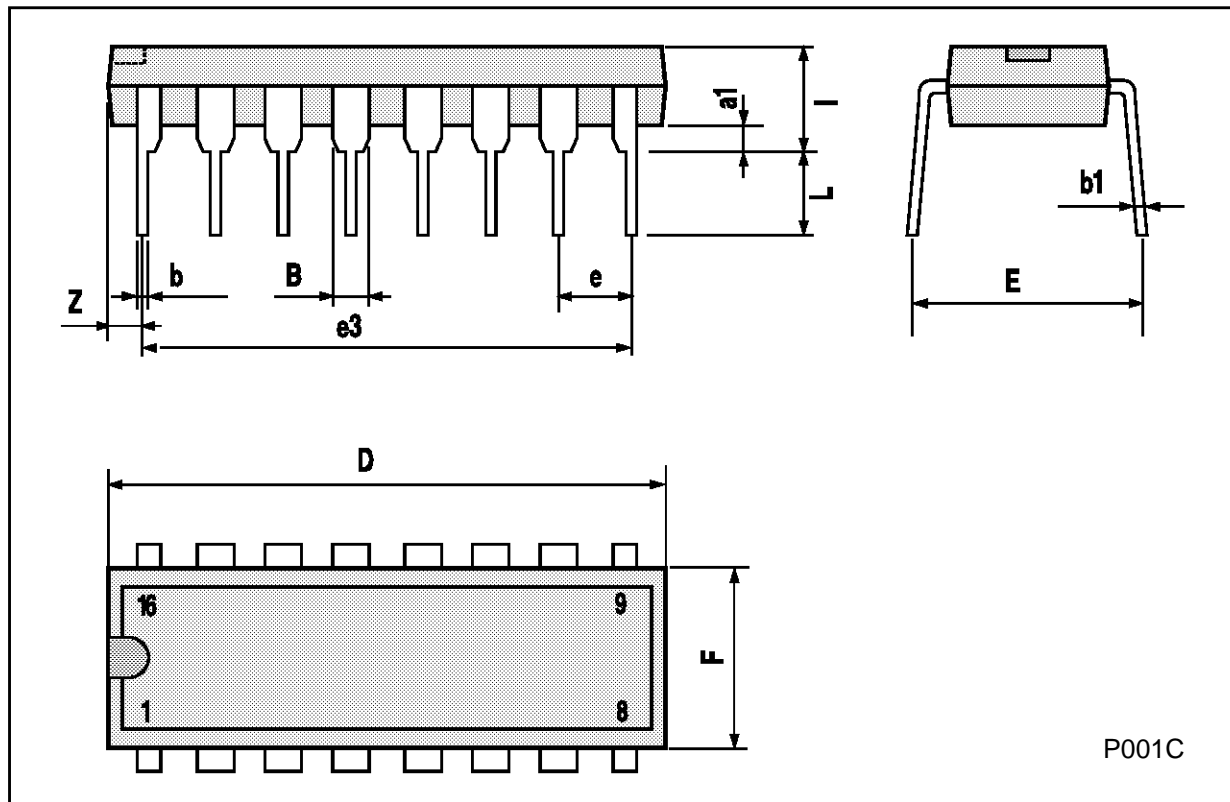

Figure 16 : Pulse Delay.



Plastic DIP16 (0.25) MECHANICAL DATA

DIM.	mm			inch		
	MIN.	TYP.	MAX.	MIN.	TYP.	MAX.
a1	0.51			0.020		
B	0.77		1.65	0.030		0.065
b		0.5			0.020	
b1		0.25			0.010	
D			20			0.787
E		8.5			0.335	
e		2.54			0.100	
e3		17.78			0.700	
F			7.1			0.280
I			5.1			0.201
L		3.3			0.130	
Z			1.27			0.050



P001C

Ceramic DIP16/1 MECHANICAL DATA

DIM.	mm			inch		
	MIN.	TYP.	MAX.	MIN.	TYP.	MAX.
A			20			0.787
B			7			0.276
D		3.3			0.130	
E	0.38			0.015		
e3		17.78			0.700	
F	2.29		2.79	0.090		0.110
G	0.4		0.55	0.016		0.022
H	1.17		1.52	0.046		0.060
L	0.22		0.31	0.009		0.012
M	0.51		1.27	0.020		0.050
N			10.3			0.406
P	7.8		8.05	0.307		0.317
Q			5.08			0.200

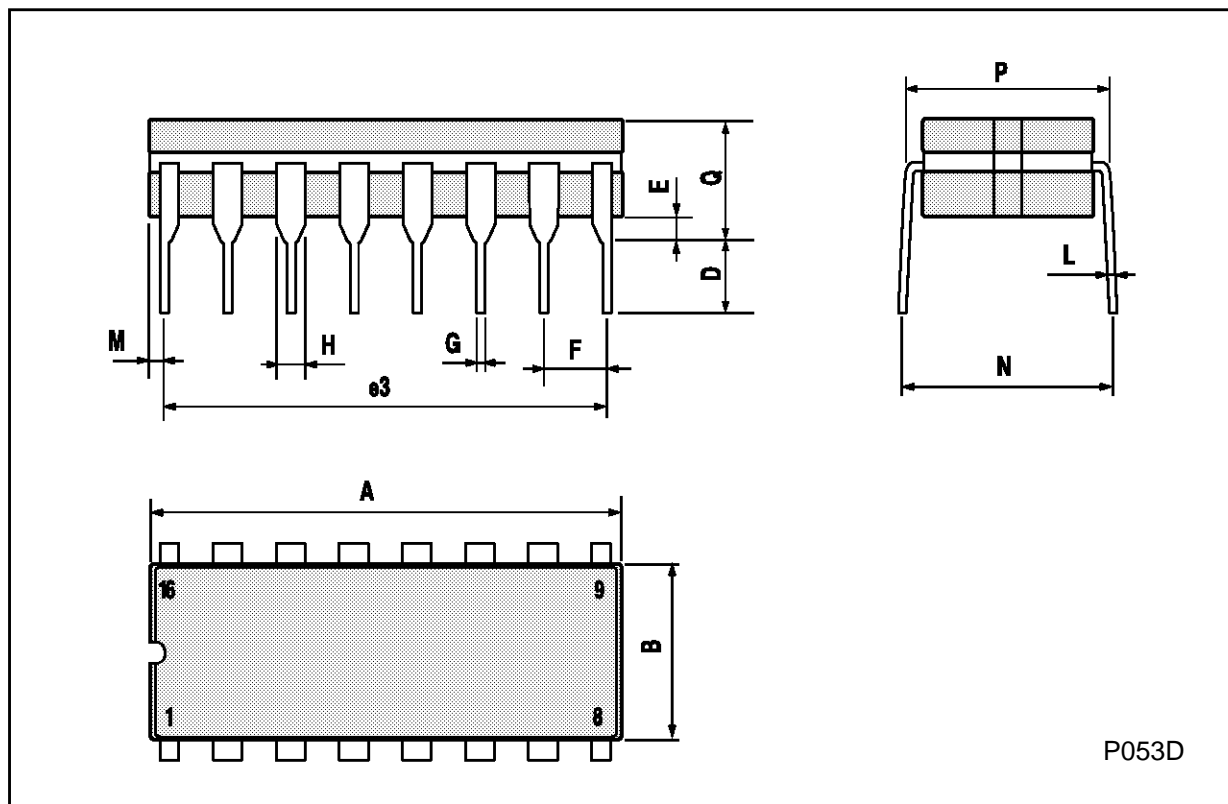

SO16 (Narrow) MECHANICAL DATA

DIM.	mm			inch		
	MIN.	TYP.	MAX.	MIN.	TYP.	MAX.
A			1.75			0.068
a1	0.1		0.2	0.004		0.007
a2			1.65			0.064
b	0.35		0.46	0.013		0.018
b1	0.19		0.25	0.007		0.010
C		0.5			0.019	
c1	45° (typ.)					
D	9.8		10	0.385		0.393
E	5.8		6.2	0.228		0.244
e		1.27			0.050	
e3		8.89			0.350	
F	3.8		4.0	0.149		0.157
G	4.6		5.3	0.181		0.208
L	0.5		1.27	0.019		0.050
M			0.62			0.024
S	8° (max.)					



P013H

PLCC20 MECHANICAL DATA

DIM.	mm			inch		
	MIN.	TYP.	MAX.	MIN.	TYP.	MAX.
A	9.78		10.03	0.385		0.395
B	8.89		9.04	0.350		0.356
D	4.2		4.57	0.165		0.180
d1		2.54			0.100	
d2		0.56			0.022	
E	7.37		8.38	0.290		0.330
e		1.27			0.050	
e3		5.08			0.200	
F		0.38			0.015	
G			0.101			0.004
M		1.27			0.050	
M1		1.14			0.045	

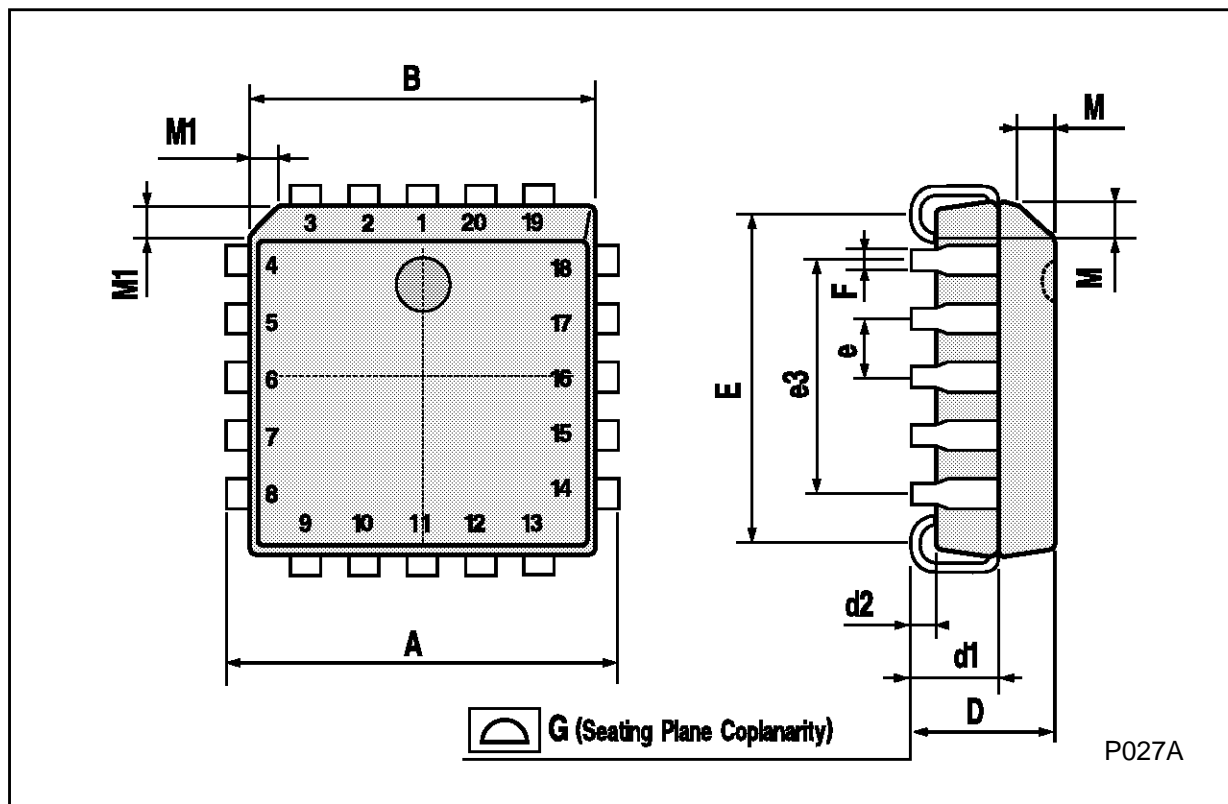

Information furnished is believed to be accurate and reliable. However, SGS-THOMSON Microelectronics assumes no responsibility for the consequences of use of such information nor for any infringement of patents or other rights of third parties which may result from its use. No license is granted by implication or otherwise under any patent or patent rights of SGS-THOMSON Microelectronics. Specifications mentioned in this publication are subject to change without notice. This publication supersedes and replaces all information previously supplied. SGS-THOMSON Microelectronics products are not authorized for use as critical components in life support devices or systems without express written approval of SGS-THOMSON Microelectronics.

© 1994 SGS-THOMSON Microelectronics - All Rights Reserved

SGS-THOMSON Microelectronics GROUP OF COMPANIES
Australia - Brazil - France - Germany - Hong Kong - Italy - Japan - Korea - Malaysia - Malta - Morocco - The Netherlands -
Singapore - Spain - Sweden - Switzerland - Taiwan - Thailand - United Kingdom - U.S.A