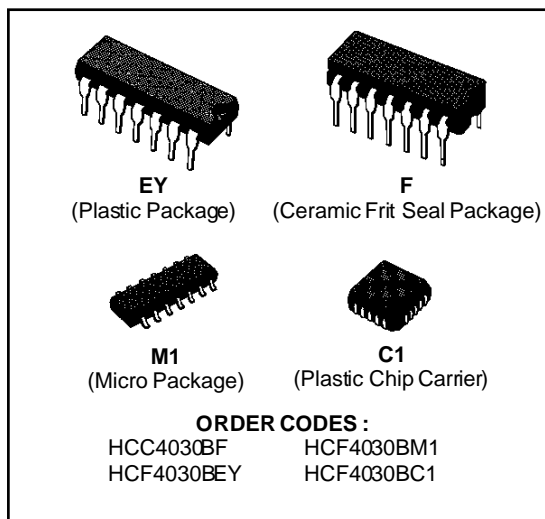

**QUAD EXCLUSIVE-OR GATE**

- MEDIUM-SPEED OPERATION –  $t_{PHL} = t_{PLH} = 60\text{ns}$  (typ.) @  $C_L = 50\text{pF}$  and  $V_{DD} - V_{SS} = 10\text{V}$
- LOW OUTPUT IMPEDANCE :  $500\Omega$  (typ.) @  $V_{DD} - V_{SS} = 10\text{V}$
- QUIESCENT CURRENT SPECIFIED TO 20V FOR HCC DEVICE
- STANDARDIZED SYMMETRICAL OUTPUT CHARACTERISTICS
- 5V, 10V, AND 15V PARAMETRIC RATINGS
- INPUT CURRENT OF 100nA AT 18V AND 25°C FOR HCC DEVICE
- 100% TESTED FOR QUIESCENT CURRENT
- MEETS ALL REQUIREMENTS OF JEDEC TENTATIVE STANDARD N° 13A, "STANDARD SPECIFICATIONS FOR DESCRIPTION OF "B" SERIES CMOS DEVICES"

**DESCRIPTION**

The **HCC4030B** (extended temperature range) and **HCF4030B** (intermediate temperature range) are monolithic integrated circuit, available in 14-lead dual in-line plastic or ceramic package and plastic micro package.

The **HCC/HCF4030B** types consist of four independent exclusive-OR gates integrated on a single monolithic silicon chip. Each exclusive-OR gate consists of four n-channel and four p-channel enhancement-type transistors. All inputs and outputs are protected against electrostatic effects.

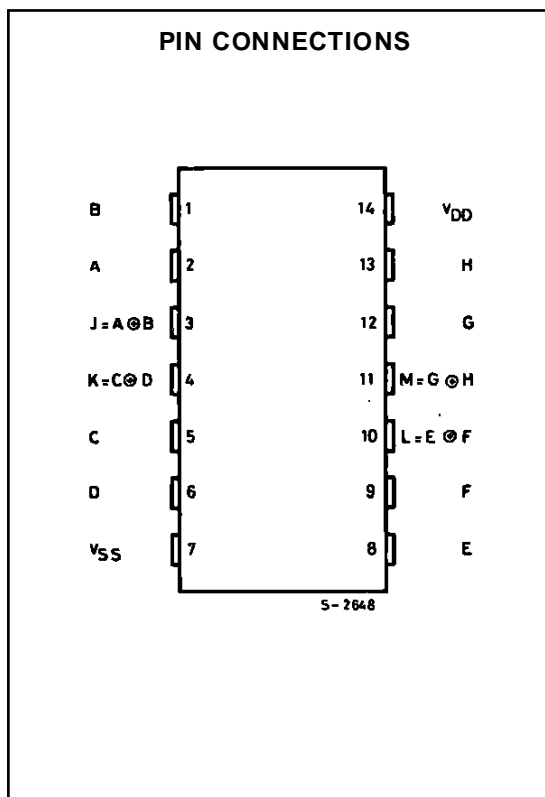

# HCC/HCF4030B

## FUNCTIONAL DIAGRAM

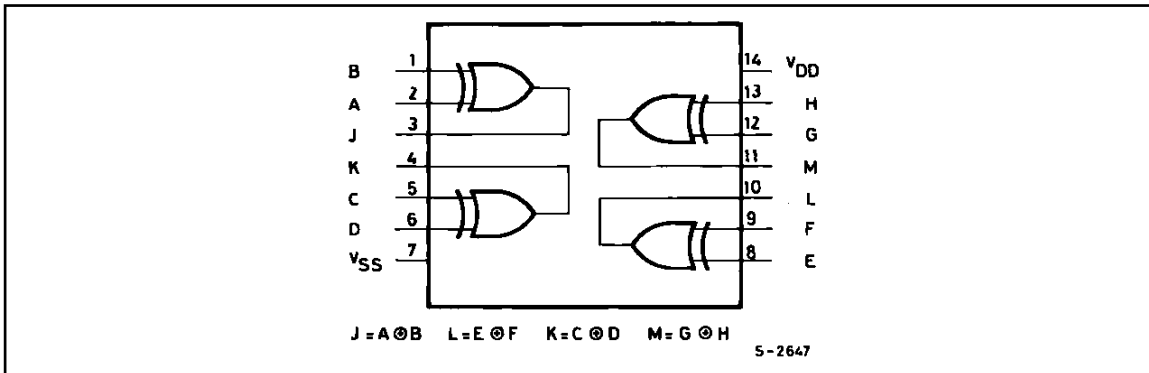

## ABSOLUTE MAXIMUM RATINGS

Symbol	Parameter	Value	Unit
$V_{DD}^*$	Supply Voltage : <b>HCC</b> Types <b>HCF</b> Types	- 0.5 to + 20 - 0.5 to + 18	V V
$V_i$	Input Voltage	- 0.5 to $V_{DD} + 0.5$	V
$I_i$	DC Input Current (any one input)	$\pm 10$	mA
$P_{tot}$	Total Power Dissipation (per package) Dissipation per Output Transistor for $T_{op}$ = Full Package-temperature Range	200	mW
		100	mW
$T_{op}$	Operating Temperature : <b>HCC</b> Types <b>HCF</b> Types	- 55 to + 125	$^{\circ}C$
		- 40 to + 85	$^{\circ}C$
$T_{stg}$	Storage Temperature	- 65 to + 150	$^{\circ}C$

Stresses above those listed under "Absolute Maximum Ratings" may cause permanent damage to the device. This is a stress rating only and functional operation of the device at these or any other conditions above those indicated in the operational sections of this specification is not implied. Exposure to absolute maximum rating conditions for external periods may affect device reliability.

## RECOMMENDED OPERATING CONDITIONS

Symbol	Parameter	Value	Unit
$V_{DD}$	Supply Voltage : <b>HCC</b> Types <b>HCF</b> Types	3 to 18	V
		3 to 15	V
$V_i$	Input Voltage	0 to $V_{DD}$	V
$T_{op}$	Operating Temperature : <b>HCC</b> Types <b>HCF</b> Types	- 55 to + 125	$^{\circ}C$
		- 40 to + 85	$^{\circ}C$

## TRUTH TABLE

One of Four Identical Gates

A	B	J
0	0	0
1	0	1
0	1	1
1	0	0

Where "1" = High level  
      "0" = Low level.

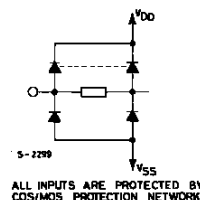

## STATIC ELECTRICAL CHARACTERISTICS (over recommended operating conditions)

Symbol	Parameter		Test Conditions				Value						Unit	
			V <sub>I</sub> (V)	V <sub>O</sub> (V)	I <sub>o</sub>   ( $\mu$ A)	V <sub>DD</sub> (V)	T <sub>Low</sub> *		25°C			T <sub>High</sub> *		
							Min.	Max.	Min.	Typ.	Max.	Min.		Max.
I <sub>L</sub>	Quiescent Current	HCC Types	0/ 5			5		1		0.02	1		30	$\mu$ A
			0/10			10		2		0.02	2		60	
			0/15			15		4		0.02	4		120	
			0/20			20		20		0.04	20		600	
		HCF Types	0/ 5			5		4		0.02	4		30	
			0/10			10		8		0.02	8		60	
			0/15			15		16		0.02	16		120	
V <sub>OH</sub>	Output High Voltage	0/ 5		< 1	5	4.95		4.95			4.95		V	
		0/10		< 1	10	9.95		9.95			9.95			
		0/15		< 1	15	14.95		14.95			14.95			
V <sub>OL</sub>	Output Low Voltage	5/0		< 1	5		0.05			0.05		0.05	V	
		10/0		< 1	10		0.05			0.05		0.05		
		15/0		< 1	15		0.05			0.05		0.05		
V <sub>IH</sub>	Input High Voltage		0.5/4.5	< 1	5	3.5		3.5			3.5		V	
			1/9	< 1	10	7		7			7			
			1.5/13.5	< 1	15	11		11			11			
V <sub>IL</sub>	Input Low Voltage		4.5/0.5	< 1	5		1.5			1.5		1.5	V	
			9/1	< 1	10		3			3		3		
			13.5/1.5	< 1	15		4			4		4		
I <sub>OH</sub>	Output Drive Current	HCC Types	0/ 5	2.5		5	- 2		- 1.6	- 3.2		- 1.15	mA	
			0/ 5	4.6		5	- 0.64		- 0.51	- 1		- 0.36		
			0/10	9.5		10	- 1.6		- 1.3	- 2.6		- 0.9		
			0/15	13.5		15	- 4.2		- 3.4	- 6.8		- 2.4		
		HCF Types	0/ 5	2.5		5	- 1.53		- 1.36	- 3.2		- 1.1		
			0/ 5	4.6		5	- 0.52		- 0.44	- 1		- 0.36		
			0/10	9.5		10	- 1.3		- 1.1	- 2.6		- 0.9		
	0/15	13.5		15	- 3.6		- 3.0	- 6.8		- 2.4				
I <sub>OL</sub>	Output Sink Current	HCC Types	0/ 5	0.4		5	0.64		0.51	1		0.36	mA	
			0/10	0.5		10	1.6		1.3	2.6		0.9		
			0/15	1.5		15	4.2		3.4	6.8		2.4		
		HCF Types	0/ 5	0.4		5	0.52		0.44	1		0.36		
			0/10	0.5		10	1.3		1.1	2.6		0.9		
			0/15	1.5		15	3.6		3.0	6.8		2.4		
I <sub>IH</sub> , I <sub>IL</sub>	Input Leakage Current	HCC Types	0/18	Any Input		18		$\pm$ 0.1		$\pm$ 10 <sup>-5</sup>	$\pm$ 0.1		$\pm$ 1	$\mu$ A
		HCF Types	0/15											
C <sub>I</sub>	Input Capacitance		Any Input						5	7.5			pF	

\* T<sub>Low</sub> = - 55°C for HCC device : - 40°C for HCF device.\* T<sub>High</sub> = + 125°C for HCC device : + 85°C for HCF device.The Noise Margin for both "1" and "0" level is : 1V min. with V<sub>DD</sub> = 5V, 2V min. with V<sub>DD</sub> = 10V, 2.5 V min. with V<sub>DD</sub> = 15V.

# HCC/HCF4030B

**DYNAMIC ELECTRICAL CHARACTERISTICS** ( $T_{amb} = 25^{\circ}\text{C}$ ,  $C_L = 50\text{pF}$ ,  $R_L = 200\text{k}\Omega$ , typical temperature coefficient for all  $V_{DD} = 0.3\%/^{\circ}\text{C}$  values, all input rise and fall time = 20ns)

Symbol	Parameter	Test Conditions		Value			Unit
			$V_{CC}$ (V)	Min.	Typ.	Max.	
$t_{PLH}$ , $t_{PHL}$	Propagation Delay Time		5		140	280	ns
			10		65	130	
			15		50	100	
$t_{TLH}$ , $t_{THL}$	Transition Time		5		100	200	ns
			10		50	100	
			15		40	80	

Typical Output Low (sink) Current Characteristics.

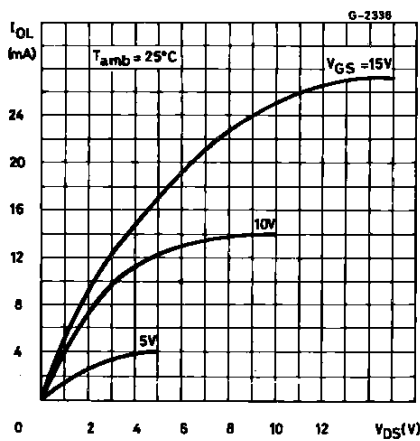

Minimum Output Low (sink) Current Characteristics.

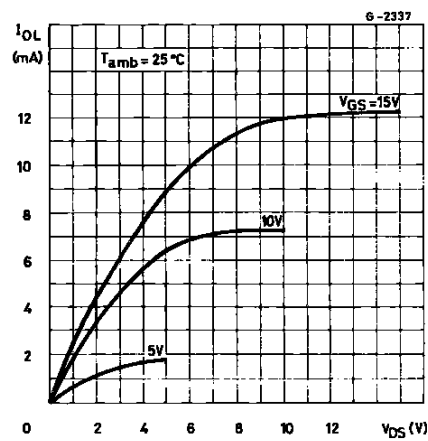

Typical Output High (source) Current Characteristics.

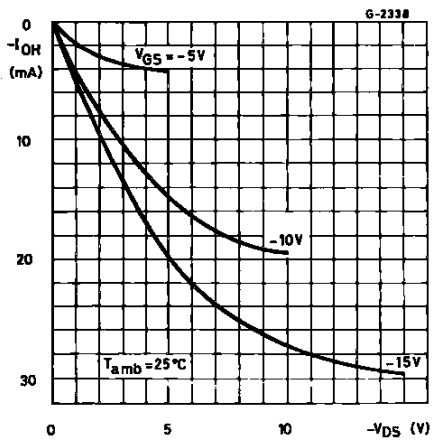

Minimum Output High (source) Current Characteristics.

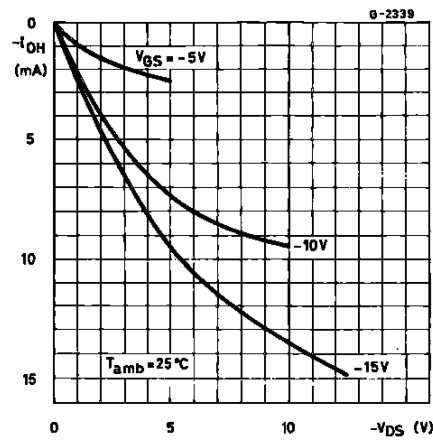

TYPICAL APPLICATIONS

EVEN-PARITY-BIT GENERATOR  
(1-3/4 x HCC/HCF4030B).

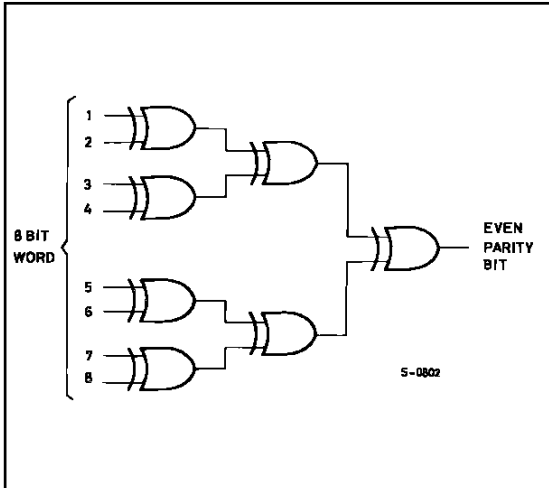

EVEN-PARITY-CHECKER  
(2 x HCC/HCF4030B).

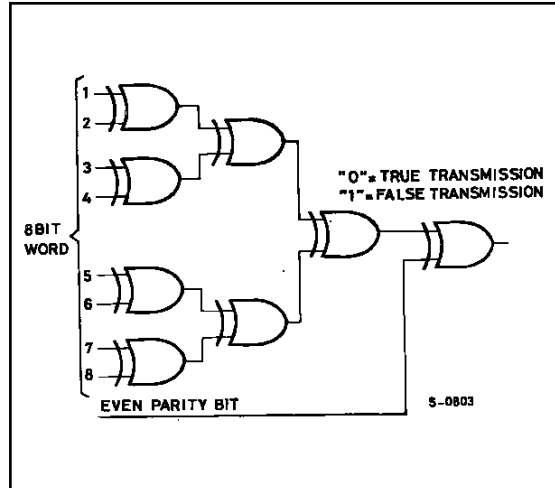

ODD-PARITY-BIT GENERATOR  
(2 x HCC/HCF4030B).

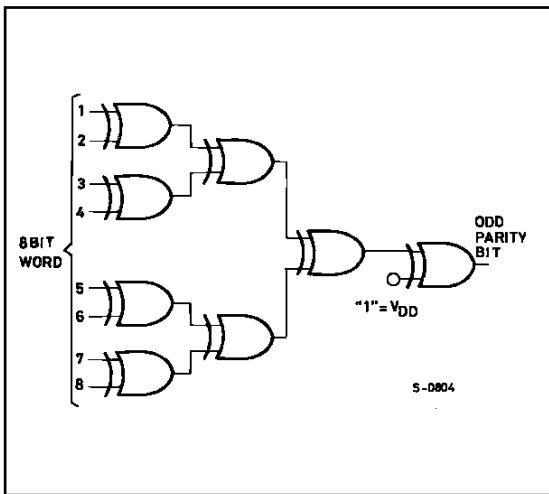

ODD-PARITY CHECKER  
(2 x HCC/HCF4030B).

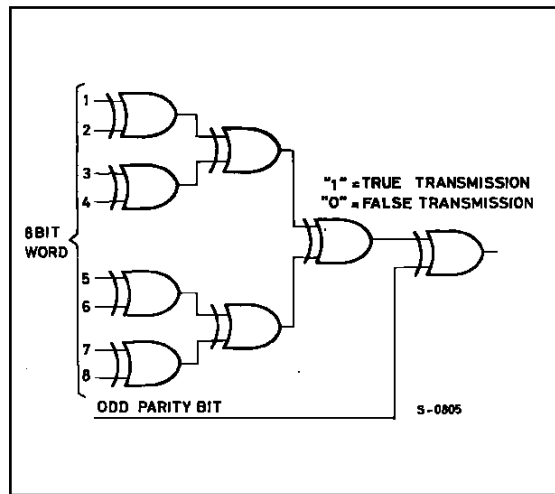

# HCC/HCF4030B

## TYPICAL APPLICATIONS (continued)

### 8-BIT COMPARATOR

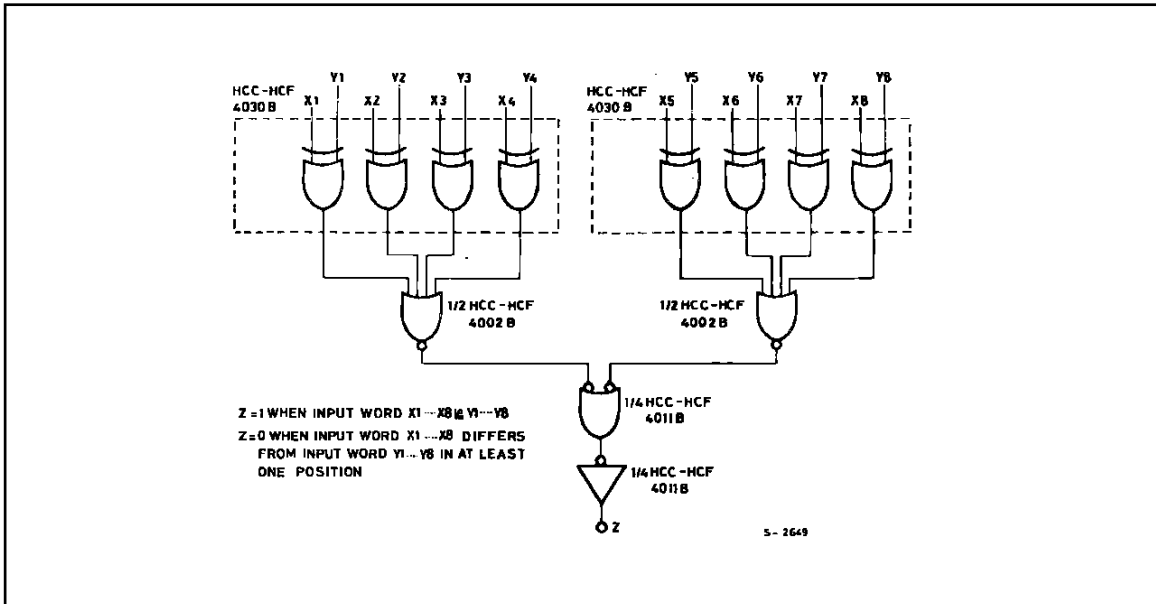

### 8-BIT TWO'S COMPLEMENT ADDER-SUBTRACTOR

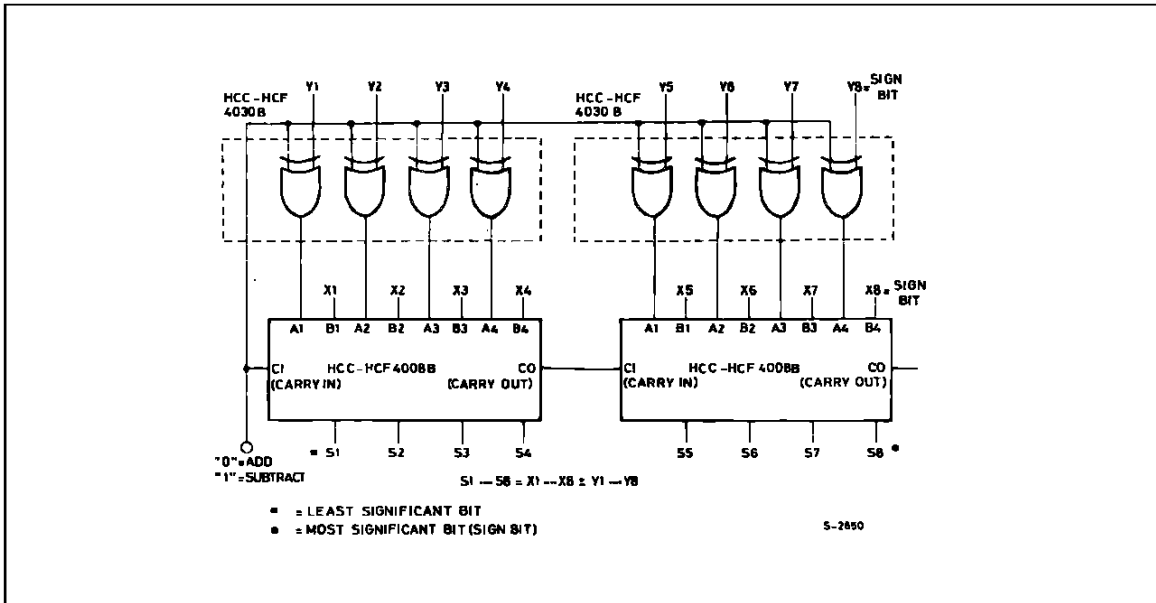

**Table 1 :** Two's Complement Numbers and Their Equivalent Decimal Values.

X8	X7	X6	X5	X4	X3	X2	X1		X8	X7	X6	X5	X4	X3	X2	X1	
0	0	0	0	0	0	0	0	= 0	1	1	1	1	1	1	1	1	= -1
0	0	0	0	0	0	0	1	= 1	1	1	1	1	1	1	1	0	= -2
0	0	0	0	0	0	1	0	= 2	1	1	1	1	1	1	0	1	= -3
0	0	0	0	0	0	1	1	= 3	1	1	1	1	1	1	0	0	= -4
									1	1	1	1	1	0	1	1	= -5
0	1	1	1	1	1	1	0	= 126	1	0	0	0	0	0	0	1	= -127
0	1	1	1	1	1	1	1	= 127	1	0	0	0	0	0	0	0	= -128

The two's complement adder-subtractor can add or subtract any two of the numbers in table 1. For example :

a)  $2 + (-5) = -3$

		SIGN								
+	=	BIT								
-5	X	0	0	0	0	0	1	0	2 +	
	Y	1	1	1	1	1	0	1	-5 +	
	CI								0	
	S	0	1	1	1	1	1	0	1 = -3	
	CO									

b)  $-2 + (-5) = -7$

		SIGN								
-	=	BIT								
-2	X	1	1	1	1	1	1	0	-2 +	
-5	Y	1	1	1	1	0	1	1	-5 +	
	Y	0	0	0	0	1	0	0	+	
	CL								1	
	S	1	0	0	0	0	0	1	1 = -7	
	CO									

**TEST CIRCUITS**

Quiescent Device Current

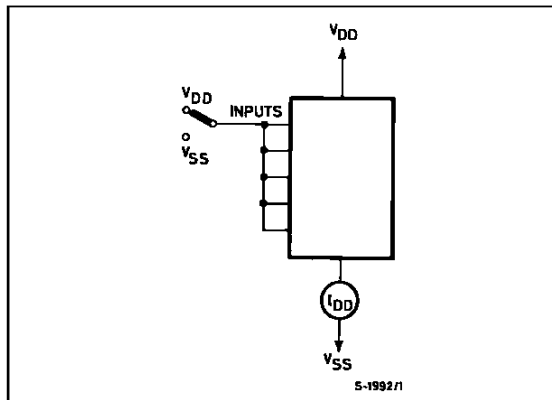

Input Voltage

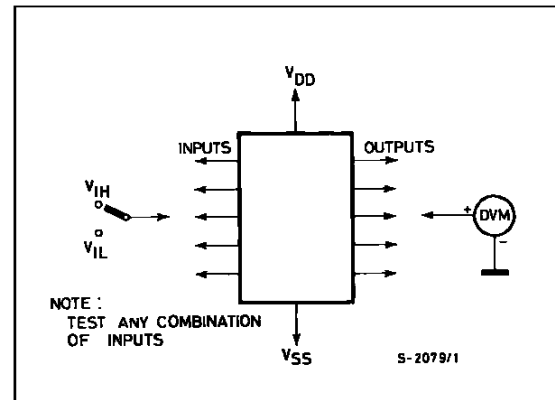

Input Leakage Current

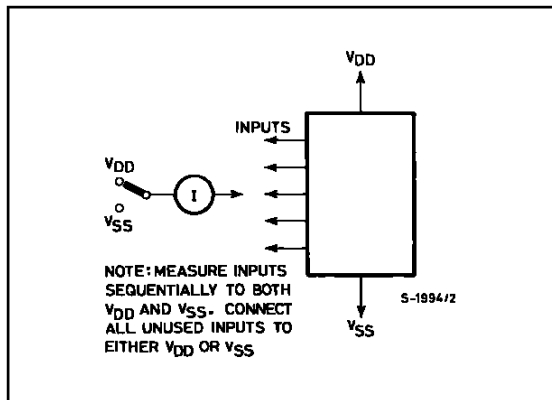

**Plastic DIP14 MECHANICAL DATA**

DIM.	mm			inch		
	MIN.	TYP.	MAX.	MIN.	TYP.	MAX.
a1	0.51			0.020		
B	1.39		1.65	0.055		0.065
b		0.5			0.020	
b1		0.25			0.010	
D			20			0.787
E		8.5			0.335	
e		2.54			0.100	
e3		15.24			0.600	
F			7.1			0.280
l			5.1			0.201
L		3.3			0.130	
Z	1.27		2.54	0.050		0.100

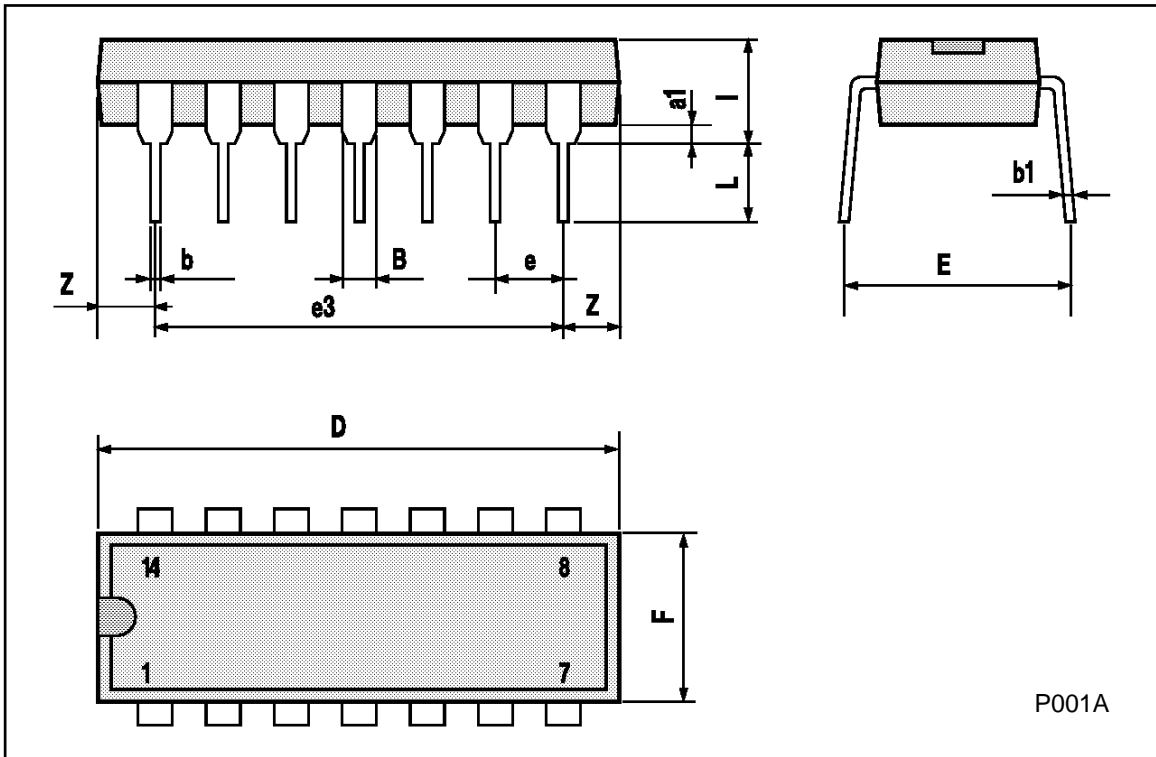



## Ceramic DIP14/1 MECHANICAL DATA

DIM.	mm			inch		
	MIN.	TYP.	MAX.	MIN.	TYP.	MAX.
A			20			0.787
B			7.0			0.276
D		3.3			0.130	
E	0.38			0.015		
e3		15.24			0.600	
F	2.29		2.79	0.090		0.110
G	0.4		0.55	0.016		0.022
H	1.17		1.52	0.046		0.060
L	0.22		0.31	0.009		0.012
M	1.52		2.54	0.060		0.100
N			10.3			0.406
P	7.8		8.05	0.307		0.317
Q			5.08			0.200

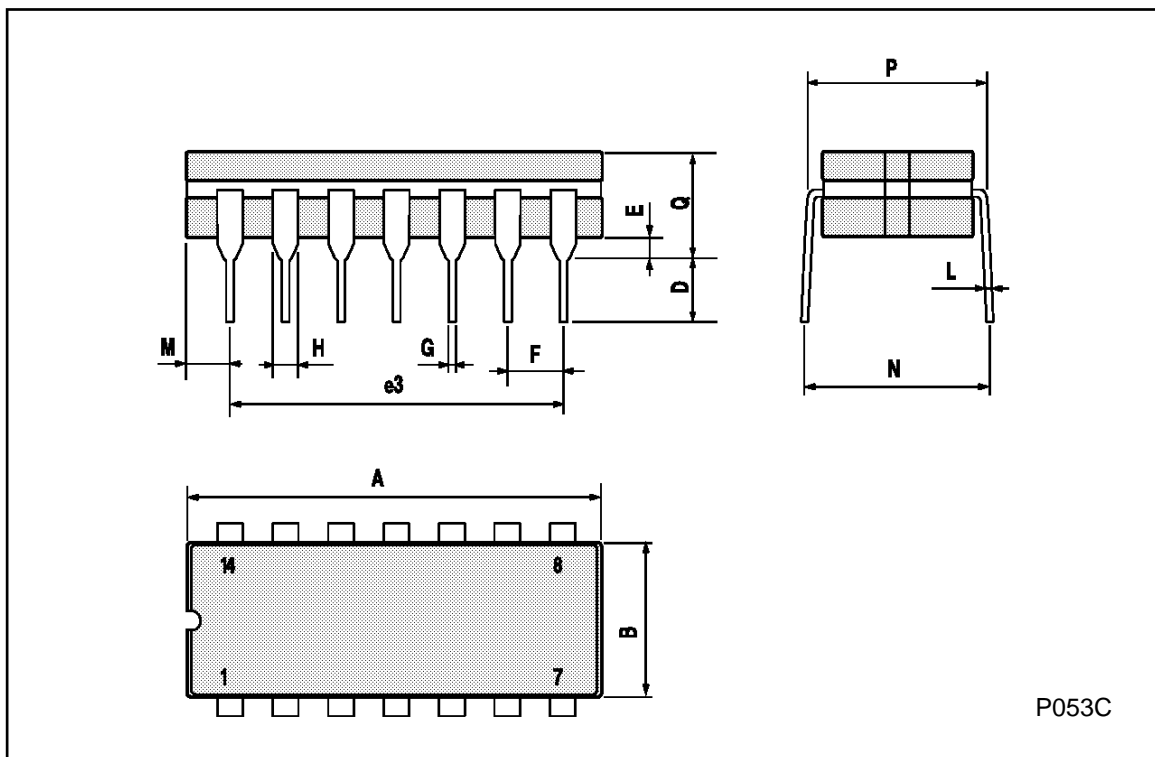

**SO14 MECHANICAL DATA**

DIM.	mm			inch		
	MIN.	TYP.	MAX.	MIN.	TYP.	MAX.
A			1.75			0.068
a1	0.1		0.2	0.003		0.007
a2			1.65			0.064
b	0.35		0.46	0.013		0.018
b1	0.19		0.25	0.007		0.010
C		0.5			0.019	
c1	45° (typ.)					
D	8.55		8.75	0.336		0.344
E	5.8		6.2	0.228		0.244
e		1.27			0.050	
e3		7.62			0.300	
F	3.8		4.0	0.149		0.157
G	4.6		5.3	0.181		0.208
L	0.5		1.27	0.019		0.050
M			0.68			0.026
S	8° (max.)					

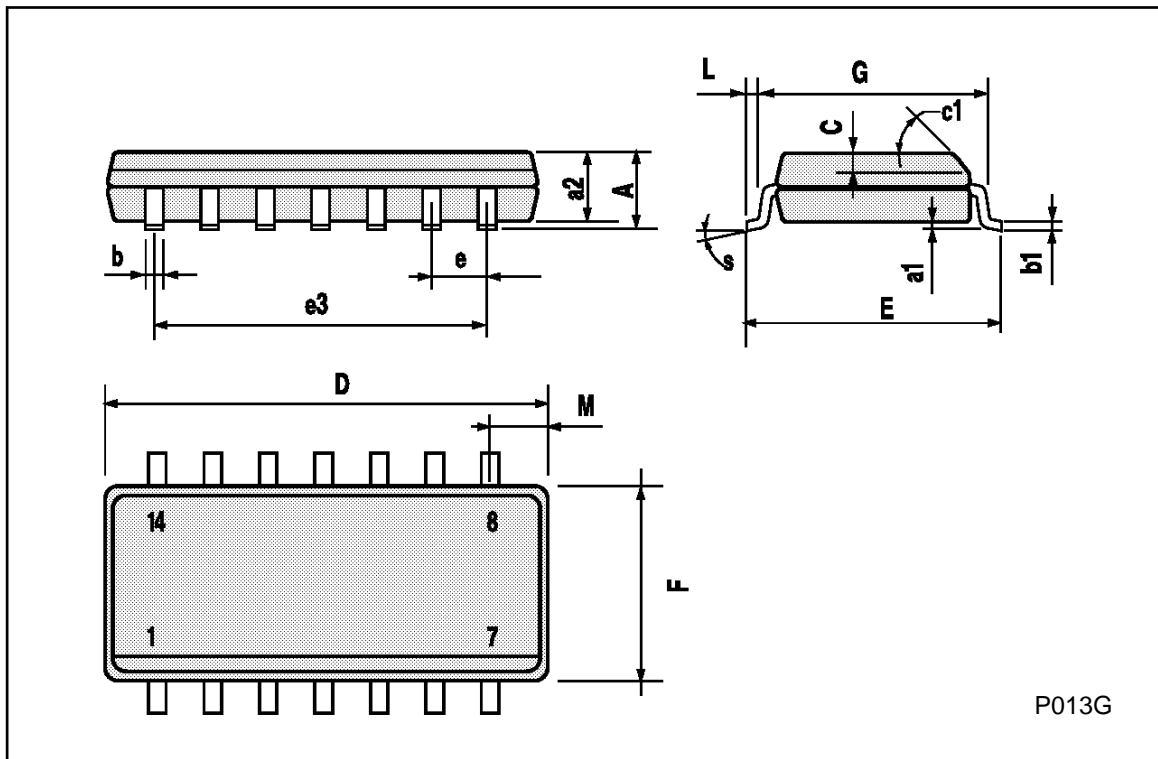

P013G

## PLCC20 MECHANICAL DATA

DIM.	mm			inch		
	MIN.	TYP.	MAX.	MIN.	TYP.	MAX.
A	9.78		10.03	0.385		0.395
B	8.89		9.04	0.350		0.356
D	4.2		4.57	0.165		0.180
d1		2.54			0.100	
d2		0.56			0.022	
E	7.37		8.38	0.290		0.330
e		1.27			0.050	
e3		5.08			0.200	
F		0.38			0.015	
G			0.101			0.004
M		1.27			0.050	
M1		1.14			0.045	

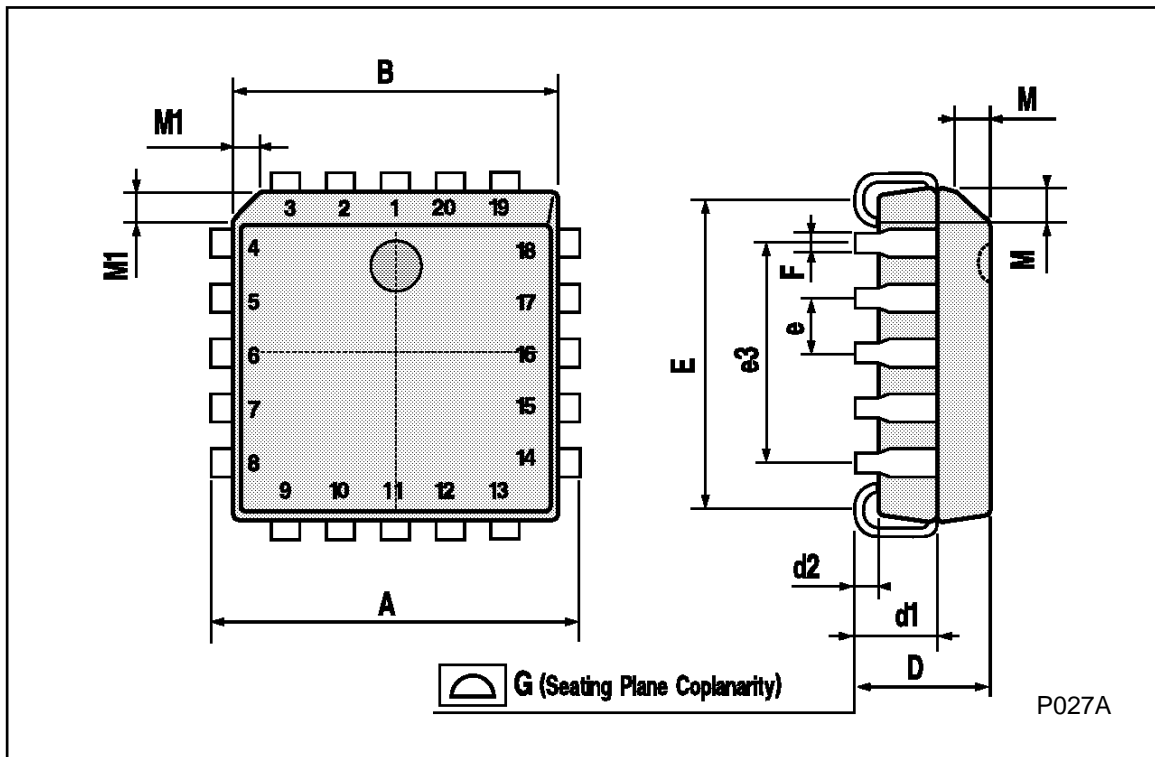

Information furnished is believed to be accurate and reliable. However, SGS-THOMSON Microelectronics assumes no responsibility for the consequences of use of such information nor for any infringement of patents or other rights of third parties which may result from its use. No license is granted by implication or otherwise under any patent or patent rights of SGS-THOMSON Microelectronics. Specifications mentioned in this publication are subject to change without notice. This publication supersedes and replaces all information previously supplied. SGS-THOMSON Microelectronics products are not authorized for use as critical components in life support devices or systems without express written approval of SGS-THOMSON Microelectronics.

© 1996 SGS-THOMSON Microelectronics - Printed in Italy - All Rights Reserved

SGS-THOMSON Microelectronics GROUP OF COMPANIES

Australia - Brazil - Canada - China - France - Germany - Hong Kong - Italy - Japan - Korea - Malaysia - Malta - Morocco - The Netherlands - Singapore - Spain - Sweden - Switzerland - Taiwan - Thailand - United Kingdom - U.S.A