



74VHC374

OCTAL D-TYPE FLIP FLOP WITH 3 STATE OUTPUT NON INVERTING

- HIGH SPEED:
 - $f_{MAX} = 270 \text{ MHz}$ (TYP.) at $V_{CC} = 5 \text{ V}$
- LOW POWER DISSIPATION:
 - $I_{CC} = 4 \mu\text{A}$ (MAX.) at $T_A = 25 \text{ }^\circ\text{C}$
- HIGH NOISE IMMUNITY:
 - $V_{NIH} = V_{NIL} = 28\% V_{CC}$ (MIN.)
- POWER DOWN PROTECTION ON INPUTS
- SYMMETRICAL OUTPUT IMPEDANCE:
 - $|I_{OH}| = I_{OL} = 8 \text{ mA}$ (MIN)
- BALANCED PROPAGATION DELAYS:
 - $t_{PLH} \cong t_{PHL}$
- OPERATING VOLTAGE RANGE:
 - V_{CC} (OPR) = 2V to 5.5V
- PIN AND FUNCTION COMPATIBLE WITH 74 SERIES 374
- IMPROVED LATCH-UP IMMUNITY
- LOW NOISE $V_{OLP} = 0.9 \text{ V}$ (Max.)

DESCRIPTION

The 74VHC374 is an advanced high-speed CMOS OCTAL D-TYPE FLIP FLOP with 3 STATE OUTPUT NON INVERTING fabricated with sub-micron silicon gate and double-layer metal wiring C²MOS technology.

This 8 bit D-Type flip-flop is controlled by a clock input (CK) and an output enable input (\overline{OE}).

On the positive transition of the clock, the Q outputs will be set to the logic state that were

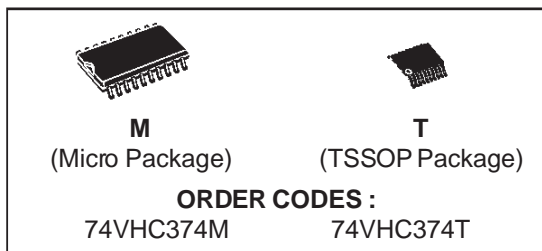

setup at the D inputs.

While the (\overline{OE}) input is low, the 8 outputs will be in a normal logic state (high or low logic level) and while high level the outputs will be in a high impedance state.

The output control does not affect the internal operation of flip flops; that is, the old data can be retained or the new data can be entered even while the outputs are off.

Power down protection is provided on all inputs and 0 to 7V can be accepted on inputs with no regard to the supply voltage. This device can be used to interface 5V to 3V.

All inputs and outputs are equipped with protection circuits against static discharge, giving them 2KV ESD immunity and transient excess voltage.

PIN CONNECTION AND IEC LOGIC SYMBOLS

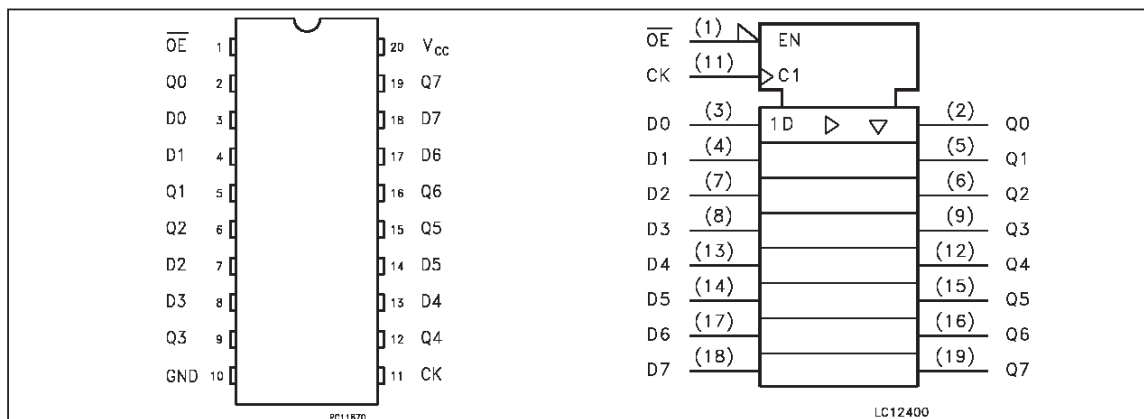

INPUT EQUIVALENT CIRCUIT

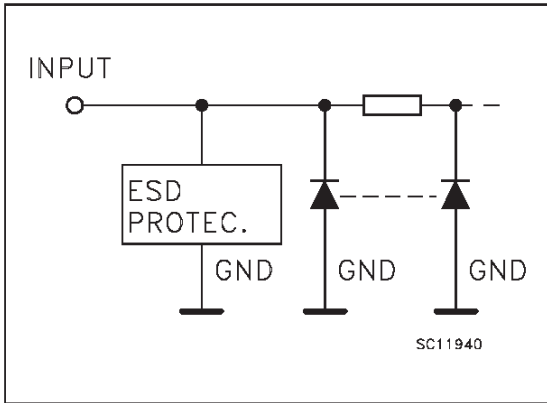

PIN DESCRIPTION

PIN No	SYMBOL	NAME AND FUNCTION
1	\overline{OE}	3 State Output Enable Input (Active LOW)
2, 5, 6, 9, 12, 15, 16, 19	Q0 to Q7	3 State Outputs
3, 4, 7, 8, 13, 14, 17, 18	D0 to D7	Data Inputs
11	CLOCK	Clock Input (LOW to HIGH, edge triggered)
10	GND	Ground (0V)
20	V _{CC}	Positive Supply Voltage

TRUTH TABLE

INPUTS			OUTPUTS
\overline{OE}	CK	D	Q
H	X	X	Z
L		X	NO CHANGE
L		L	L
L		H	H

X: Don't care
Z: High impedance

LOGIC DIAGRAM

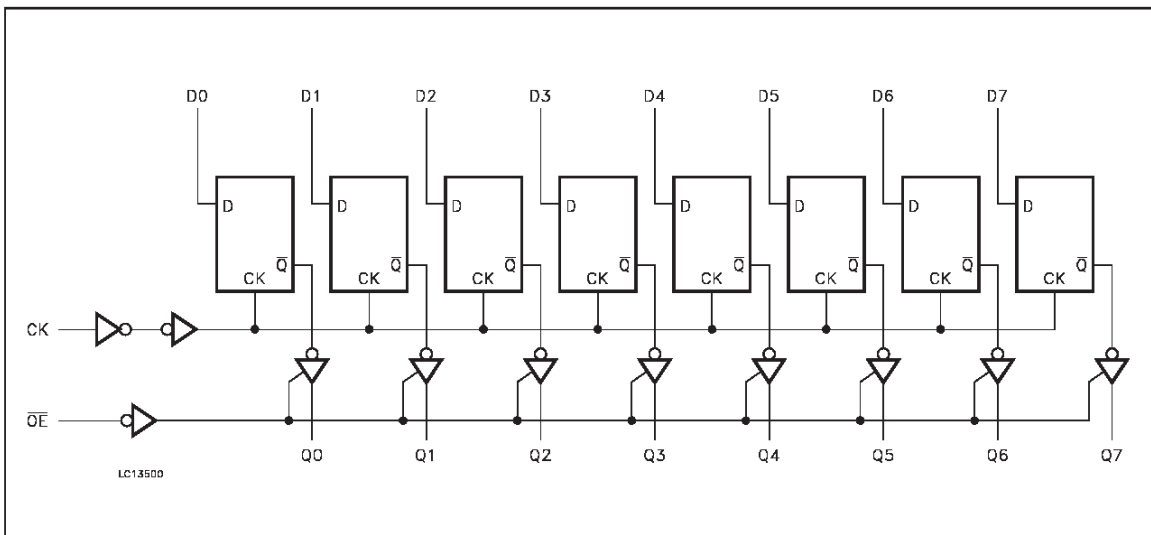

ABSOLUTE MAXIMUM RATINGS

Symbol	Parameter	Value	Unit
V_{CC}	Supply Voltage	-0.5 to +7.0	V
V_I	DC Input Voltage	-0.5 to +7.0	V
V_O	DC Output Voltage	-0.5 to $V_{CC} + 0.5$	V
I_{IK}	DC Input Diode Current	- 20	mA
I_{OK}	DC Output Diode Current	± 20	mA
I_O	DC Output Current	± 25	mA
I_{CC} or I_{GND}	DC V_{CC} or Ground Current	± 75	mA
T_{stg}	Storage Temperature	-65 to +150	$^{\circ}C$
T_L	Lead Temperature (10 sec)	300	$^{\circ}C$

Absolute Maximum Ratings are those values beyond which damage to the device may occur. Functional operation under these condition is not implied.

RECOMMENDED OPERATING CONDITIONS

Symbol	Parameter	Value	Unit
V_{CC}	Supply Voltage	2.0 to 5.5	V
V_I	Input Voltage	0 to 5.5	V
V_O	Output Voltage	0 to V_{CC}	V
T_{op}	Operating Temperature	-40 to +85	$^{\circ}C$
dt/dv	Input Rise and Fall Time (see note 1) ($V_{CC} = 3.3 \pm 0.3V$) ($V_{CC} = 5.0 \pm 0.5V$)	0 to 100 0 to 20	ns/V ns/V

1) V_{IN} from 30% to 70% of V_{CC}

DC SPECIFICATIONS

Symbol	Parameter	Test Conditions		Value					Unit	
				V_{CC} (V)	$T_A = 25^{\circ}C$			-40 to $85^{\circ}C$		
					Min.	Typ.	Max.	Min.		Max.
V_{IH}	High Level Input Voltage	2.0		1.5			1.5		V	
		3.0 to 5.5		$0.7V_{CC}$			$0.7V_{CC}$			
V_{IL}	Low Level Input Voltage	2.0				0.5		0.5	V	
		3.0 to 5.5				$0.3V_{CC}$		$0.3V_{CC}$		
V_{OH}	High Level Output Voltage	2.0	$I_O = -50 \mu A$	1.9	2.0		1.9		V	
		3.0	$I_O = -50 \mu A$	2.9	3.0		2.9			
		4.5	$I_O = -50 \mu A$	4.4	4.5		4.4			
		3.0	$I_O = -4 mA$	2.58			2.48			
		4.5	$I_O = -8 mA$	3.94			3.8			
V_{OL}	Low Level Output Voltage	2.0	$I_O = 50 \mu A$		0.0	0.1		0.1	V	
		3.0	$I_O = 50 \mu A$		0.0	0.1		0.1		
		4.5	$I_O = 50 \mu A$		0.0	0.1		0.1		
		3.0	$I_O = 4 mA$			0.36		0.44		
		4.5	$I_O = 8 mA$			0.36		0.44		
I_{OZ}	High Impedance Output Leakage Current	5.5	$V_I = V_{IH}$ or V_{IL} $V_O = V_{CC}$ or GND			± 0.25		± 2.5	μA	
I_I	Input Leakage Current	0 to 5.5	$V_I = 5.5V$ or GND			± 0.1		± 1.0	μA	
I_{CC}	Quiescent Supply Current	5.5	$V_I = V_{CC}$ or GND			4		40	μA	

AC ELECTRICAL CHARACTERISTICS (Input $t_r = t_f = 3$ ns)

Symbol	Parameter	Test Condition			Value					Unit
		V _{CC} (V)	C _L (pF)		T _A = 25 °C			-40 to 85 °C		
					Min.	Typ.	Max.	Min.	Max.	
t _{PLH} t _{PHL}	Propagation Delay Time CK to Q	3.3 ^(*)	15			8.1	12.7	1.0	15.0	ns
		3.3 ^(*)	50			10.6	16.2	1.0	18.5	
		5.0 ^(**)	15			5.4	8.1	1.0	9.5	
		5.0 ^(**)	50			6.9	10.1	1.0	11.5	
t _{PZL} t _{PZH}	Output Enable Time	3.3 ^(*)	15	R _L = 1KΩ		7.1	11.0	1.0	13.0	ns
		3.3 ^(*)	50	R _L = 1KΩ		9.6	14.5	1.0	16.5	
		5.0 ^(**)	15	R _L = 1KΩ		5.1	7.6	1.0	9.0	
		5.0 ^(**)	50	R _L = 1KΩ		6.6	9.6	1.0	11.0	
t _{PLZ} t _{PHZ}	Output Disable Time	3.3 ^(*)	50	R _L = 1KΩ		10.2	14.0	1.0	16.0	ns
		5.0 ^(**)	50	R _L = 1KΩ		6.1	8.8	1.0	10.0	
t _w	Clock Pulse Width HIGH or LOW	3.3 ^(*)					5.0		5.5	ns
		5.0 ^(**)						5.0	5.0	
t _s	Setup Time D to CK HIGH or LOW	3.3 ^(*)					4.5		4.5	ns
		5.0 ^(**)						3.0	3.0	
t _h	Hold Time D to CK HIGH or LOW	3.3 ^(*)					2.0		2.0	ns
		5.0 ^(**)						2.0	2.0	
f _{MAX}	Maximum Clock Frequency	3.3 ^(*)			60	250		60		MHz
		5.0 ^(**)			100	270		100		
t _{OSLH} t _{OSHL}	Output to Output Skew Time (note 1)	3.3 ^(*)	50				1.5		1.5	ns
		5.0 ^(**)	50					1.0	1.0	

(*) Voltage range is 3.3V ± 0.3V

(**) Voltage range is 5V ± 0.5V

Note 1: Parameter guaranteed by design. t_{SO LH} = |t_{PLHm} - t_{PLHr}|, t_{SO HL} = |t_{PHLm} - t_{PHLr}|

CAPACITIVE CHARACTERISTICS

Symbol	Parameter	Test Conditions	Value					Unit
			T _A = 25 °C			-40 to 85 °C		
			Min.	Typ.	Max.	Min.	Max.	
C _{IN}	Input Capacitance			4	10		10	pF
C _{OUT}	Output Capacitance			6				pF
C _{PD}	Power Dissipation Capacitance (note 1)			32				pF

1) C_{PD} is defined as the value of the IC's internal equivalent capacitance which is calculated from the operating current consumption without load. (Refer to Test Circuit). Average operating current can be obtained by the following equation. I_{CC(OPR)} = C_{PD} • V_{CC} • f_{IN} + I_{CC}/8 (per Flip-Flop)

DYNAMIC SWITCHING CHARACTERISTICS

Symbol	Parameter	Test Conditions		Value					Unit
		V _{CC} (V)		T _A = 25 °C			-40 to 85 °C		
				Min.	Typ.	Max.	Min.	Max.	
V _{OLP}	Dynamic Low Voltage Quiet Output (note 1, 2)	5.0	C _L = 50 pF		0.6	0.9			V
V _{OLV}				-0.9	-0.6				
V _{IHD}	Dynamic High Voltage Input (note 1, 3)	5.0		3.5					
V _{ILD}	Dynamic Low Voltage Input (note 1, 3)	5.0				1.5			

1) Worst case package.

2) Max number of outputs defined as (n). Data inputs are driven 0V to 5.0V, (n-1) outputs switching and one output at GND.

3) Max number of data inputs (n) switching. (n-1) switching 0V to 5.0V. Inputs under test switching: 5.0V to threshold (V_{ILD}), 0V to threshold (V_{IHD}), f=1MHz.

TEST CIRCUIT

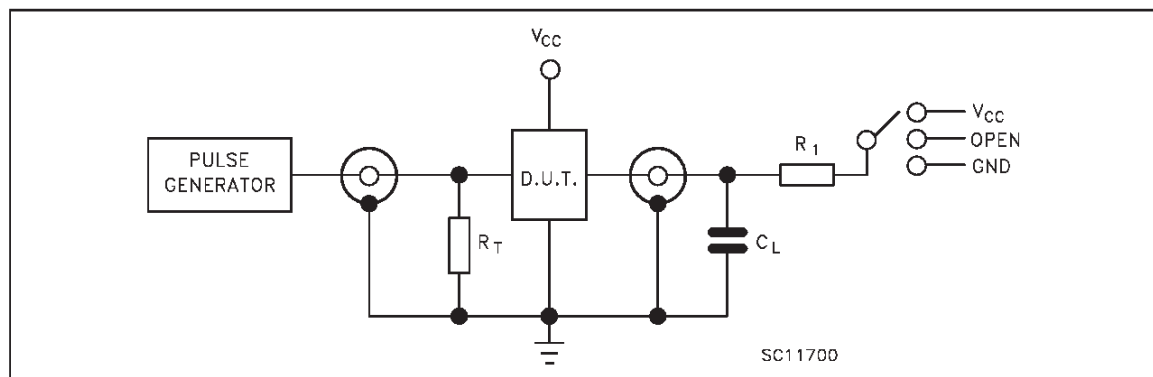

TEST	SWITCH
t _{PLH} , t _{PHL}	Open
t _{PZL} , t _{PLZ}	V _{CC}
t _{PZH} , t _{PHZ}	GND

C_L = 15/50 pF or equivalent (includes jig and probe capacitance)

R_L = R₁ = 1KΩ or equivalent

R_T = Z_{OUT} of pulse generator (typically 50Ω)

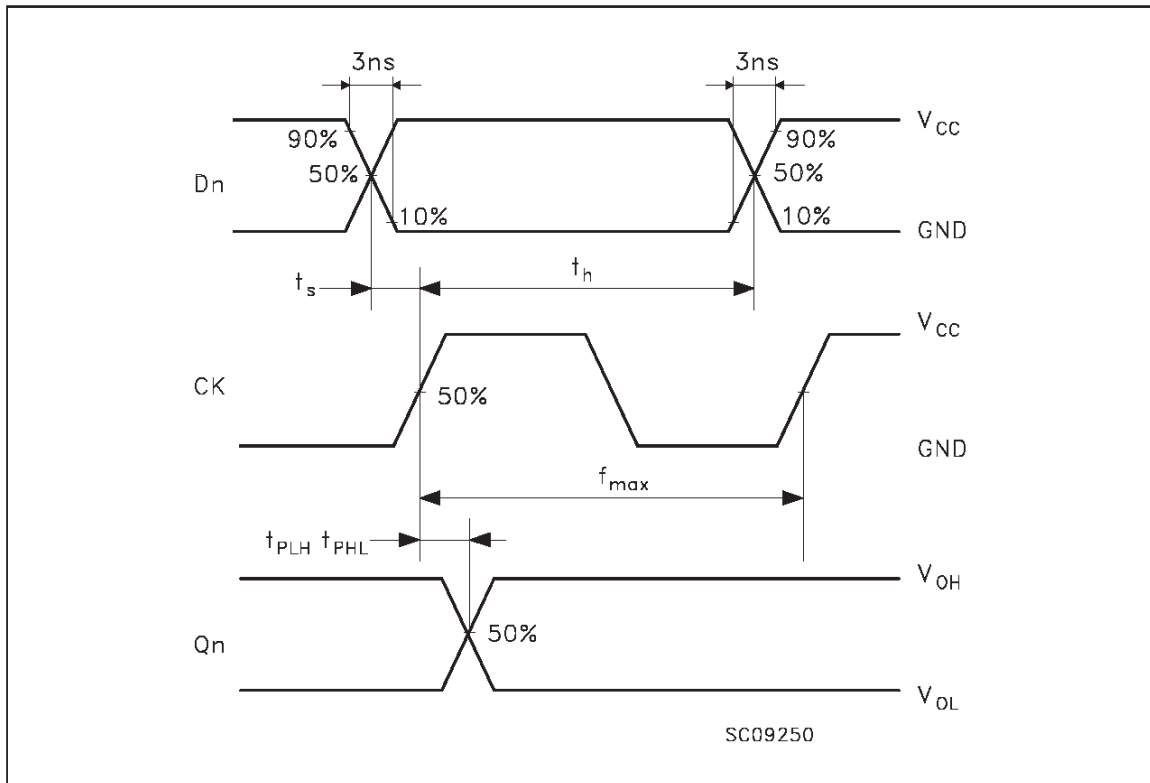
WAVEFORM 1: PROPAGATION DELAYS, SETUP AND HOLD TIMES ($f=1\text{MHz}$; 50% duty cycle)

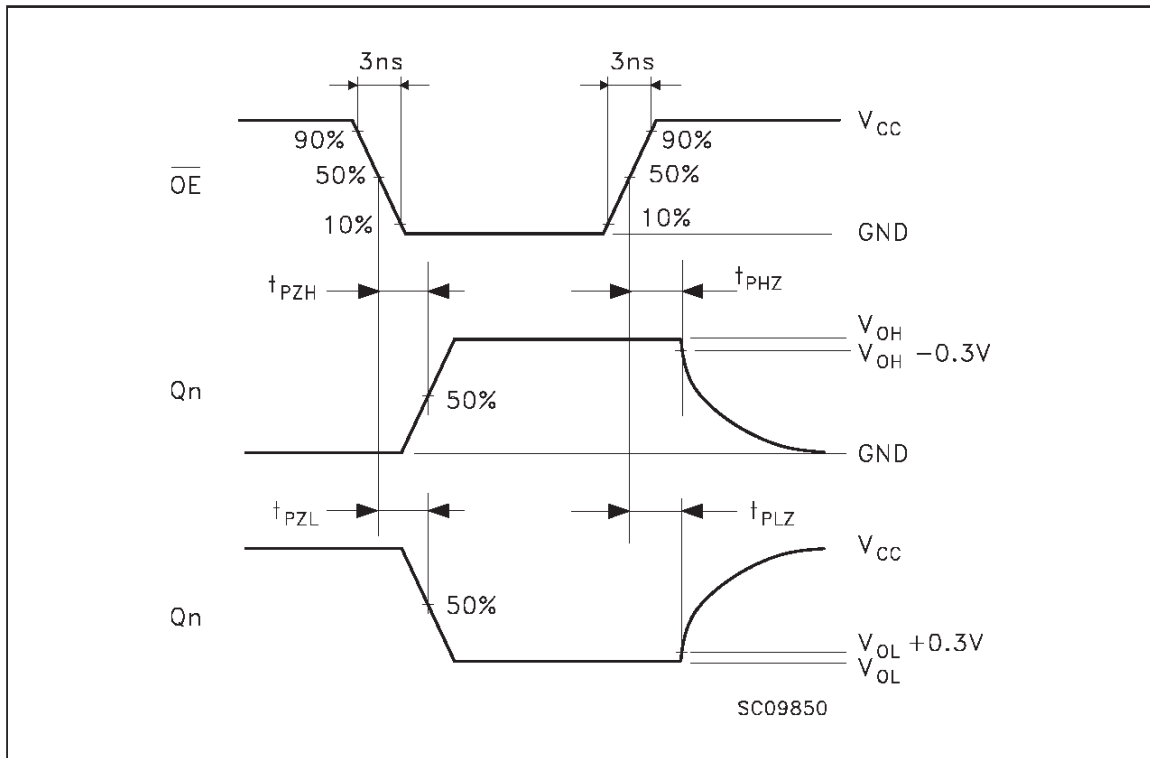
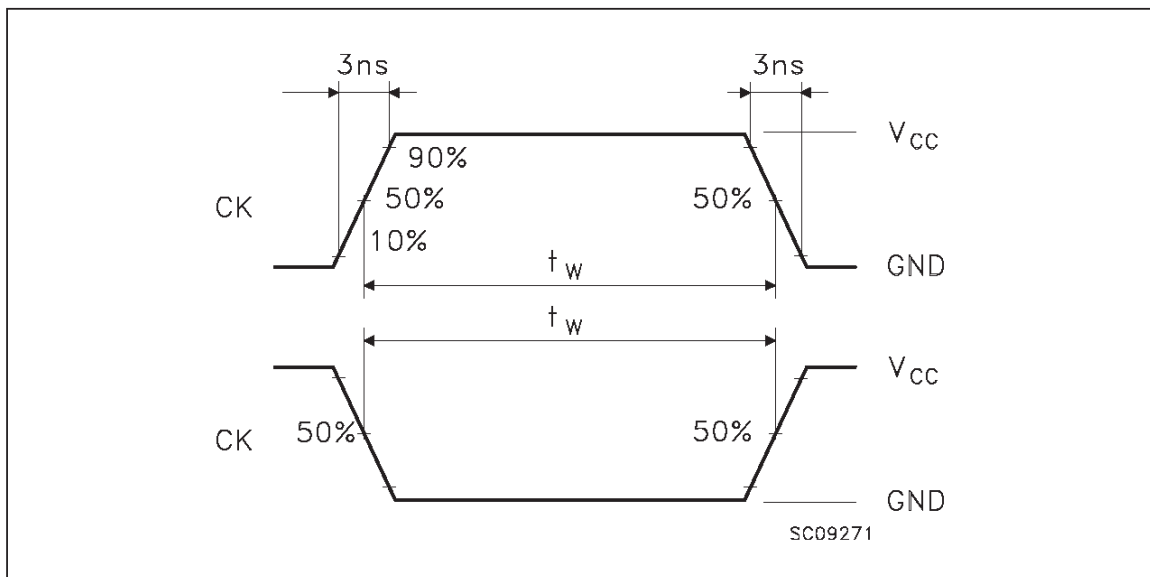
WAVEFORM 2: OUTPUT ENABLE AND DISABLE TIMES ($f=1\text{MHz}$; 50% duty cycle)**WAVEFORM 3: PULSE WIDTH**

SO-20 MECHANICAL DATA

DIM.	mm			inch		
	MIN.	TYP.	MAX.	MIN.	TYP.	MAX.
A			2.65			0.104
a1	0.10		0.20	0.004		0.007
a2			2.45			0.096
b	0.35		0.49	0.013		0.019
b1	0.23		0.32	0.009		0.012
C		0.50			0.020	
c1	45 (typ.)					
D	12.60		13.00	0.496		0.512
E	10.00		10.65	0.393		0.419
e		1.27			0.050	
e3		11.43			0.450	
F	7.40		7.60	0.291		0.299
L	0.50		1.27	0.19		0.050
M			0.75			0.029
S	8 (max.)					

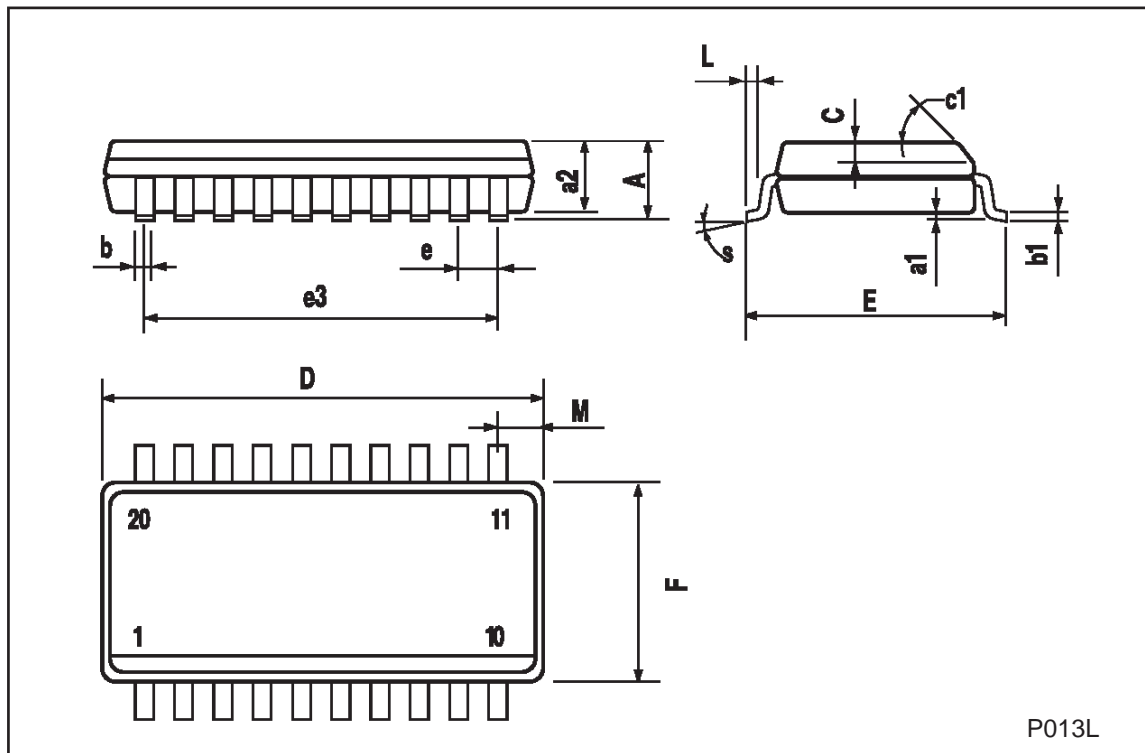

P013L

TSSOP20 MECHANICAL DATA

DIM.	mm			inch		
	MIN.	TYP.	MAX.	MIN.	TYP.	MAX.
A			1.1			0.433
A1	0.05	0.10	0.15	0.002	0.004	0.006
A2	0.85	0.9	0.95	0.335	0.354	0.374
b	0.19		0.30	0.0075		0.0118
c	0.09		0.2	0.0035		0.0079
D	6.4	6.5	6.6	0.252	0.256	0.260
E	6.25	6.4	6.5	0.246	0.252	0.256
E1	4.3	4.4	4.48	0.169	0.173	0.176
e		0.65 BSC			0.0256 BSC	
K	0°	4°	8°	0°	4°	8°
L	0.50	0.60	0.70	0.020	0.024	0.028

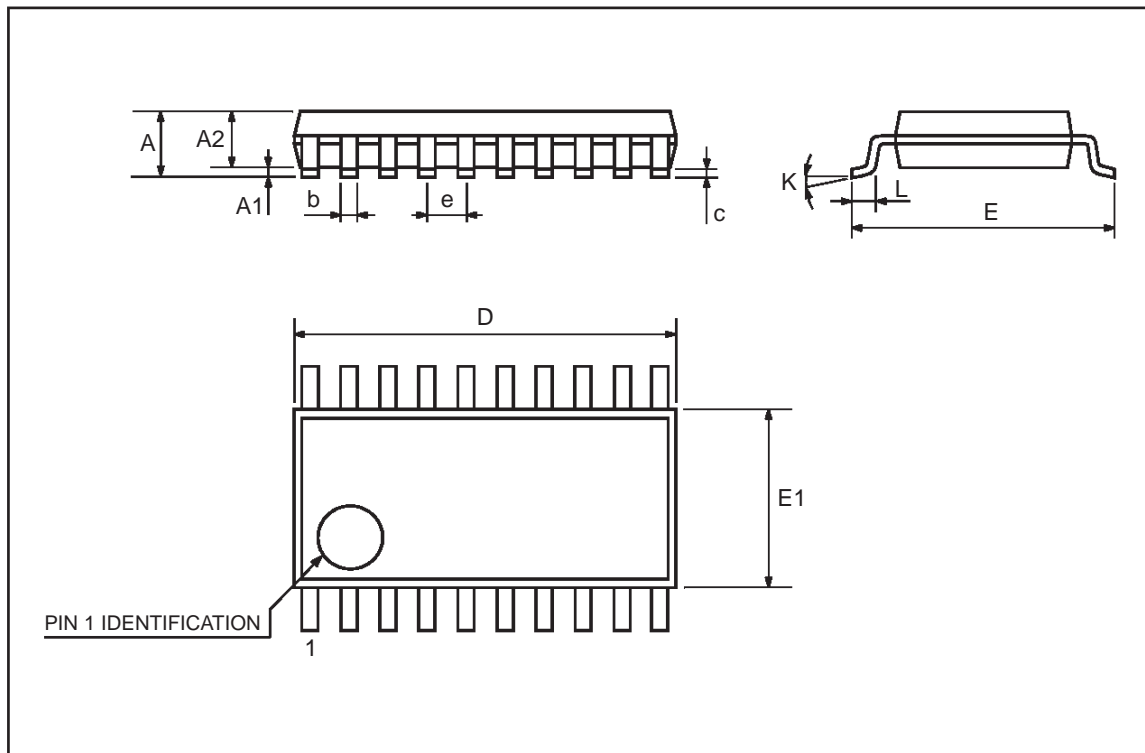

Information furnished is believed to be accurate and reliable. However, STMicroelectronics assumes no responsibility for the consequences of use of such information nor for any infringement of patents or other rights of third parties which may result from its use. No license is granted by implication or otherwise under any patent or patent rights of STMicroelectronics. Specification mentioned in this publication are subject to change without notice. This publication supersedes and replaces all information previously supplied. STMicroelectronics products are not authorized for use as critical components in life support devices or systems without express written approval of STMicroelectronics.

The ST logo is a trademark of STMicroelectronics

© 1999 STMicroelectronics – Printed in Italy – All Rights Reserved
STMicroelectronics GROUP OF COMPANIES

Australia - Brazil - Canada - China - France - Germany - Italy - Japan - Korea - Malaysia - Malta - Mexico - Morocco - The Netherlands -
Singapore - Spain - Sweden - Switzerland - Taiwan - Thailand - United Kingdom - U.S.A.
<http://www.st.com>