

DATA SHEET

For a complete data sheet, please also download:

- The IC06 74HC/HCT/HCU/HCMOS Logic Family Specifications

74HC/HCT74

Dual D-type flip-flop with set and reset; positive-edge trigger

Product specification
Supersedes data of September 1993
File under Integrated Circuits, IC06

1998 Feb 23

Dual D-type flip-flop with set and reset; positive-edge trigger

74HC/HCT74

FEATURES

- Output capability: standard
- I_{CC} category: flip-flops

GENERAL DESCRIPTION

The 74HC/HCT74 are high-speed Si-gate CMOS devices and are pin compatible with low power Schottky TTL (LSTTL). They are specified in compliance with JEDEC standard no. 7A.

The 74HC/HCT74 are dual positive-edge triggered, D-type flip-flops with individual data (D) inputs, clock (CP) inputs, set (\overline{S}_D) and reset (\overline{R}_D) inputs; also complementary Q and \overline{Q} outputs.

The set and reset are asynchronous active LOW inputs and operate independently of the clock input. Information on the data input is transferred to the Q output on the LOW-to-HIGH transition of the clock pulse. The D inputs must be stable one set-up time prior to the LOW-to-HIGH clock transition for predictable operation.

Schmitt-trigger action in the clock input makes the circuit highly tolerant to slower clock rise and fall times.

QUICK REFERENCE DATA

GND = 0 V; T_{amb} = 25 °C; t_r = t_f = 6 ns

SYMBOL	PARAMETER	CONDITIONS	TYPICAL		UNIT
			HC	HCT	
t _{PHL} / t _{PLH}	propagation delay nCP to nQ, n \overline{Q}	C _L = 15 pF; V _{CC} = 5 V	14	15	ns
	n \overline{S}_D to nQ, n \overline{Q}		15	18	ns
	n \overline{R}_D to nQ, n \overline{Q}		16	18	ns
f _{max}	maximum clock frequency		76	59	MHz
C _I	input capacitance		3.5	3.5	pF
C _{PD}	power dissipation capacitance per flip-flop	notes 1 and 2	24	29	pF

Notes

1. C_{PD} is used to determine the dynamic power dissipation (P_D in μ W):

$$P_D = C_{PD} \times V_{CC}^2 \times f_i + \sum (C_L \times V_{CC}^2 \times f_o) \text{ where:}$$

f_i = input frequency in MHz

f_o = output frequency in MHz

$\sum (C_L \times V_{CC}^2 \times f_o)$ = sum of outputs

C_L = output load capacitance in pF

V_{CC} = supply voltage in V

2. For HC the condition is V_I = GND to V_{CC}
For HCT the condition is V_I = GND to V_{CC} - 1.5 V

Dual D-type flip-flop with set and reset; positive-edge trigger

74HC/HCT74

ORDERING INFORMATION

TYPE NUMBER	PACKAGE		
	NAME	DESCRIPTION	VERSION
74HC(T)74N	DIP14	plastic dual in-line package; 14 leads (300 mil)	SOT27-1
74HC(T)74D	SO14	plastic small outline package; 14 leads; body width 3.9 mm	SOT108-1
74HCT74DB	SSOP14	plastic shrink small outline package; 14 leads; body width 5.3 mm	SOT337-1
74HCT74PW	TSSOP14	plastic thin shrink small outline package; 14 leads; body width 4.4 mm	SOT402-1

PIN DESCRIPTION

PIN NO.	SYMBOL	NAME AND FUNCTION
1, 13	$1\bar{R}_D, 2\bar{R}_D$	asynchronous reset-direct input (active LOW)
2, 12	1D, 2D	data inputs
3, 11	1CP, 2CP	clock input (LOW-to-HIGH, edge-triggered)
4, 10	$1\bar{S}_D, 2\bar{S}_D$	asynchronous set-direct input (active LOW)
5, 9	1Q, 2Q	true flip-flop outputs
6, 8	$1\bar{Q}, 2\bar{Q}$	complement flip-flop outputs
7	GND	ground (0 V)
14	V_{CC}	positive supply voltage

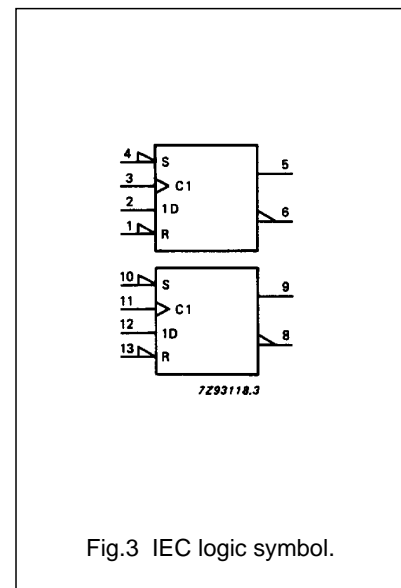
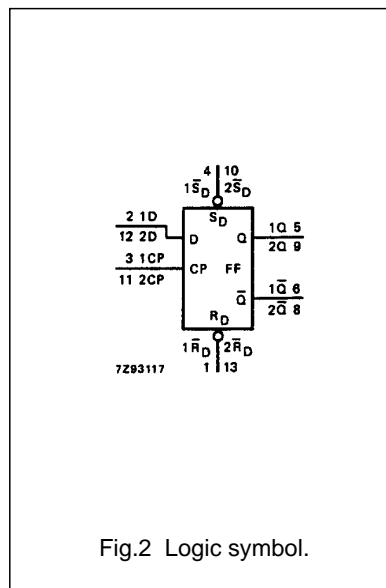
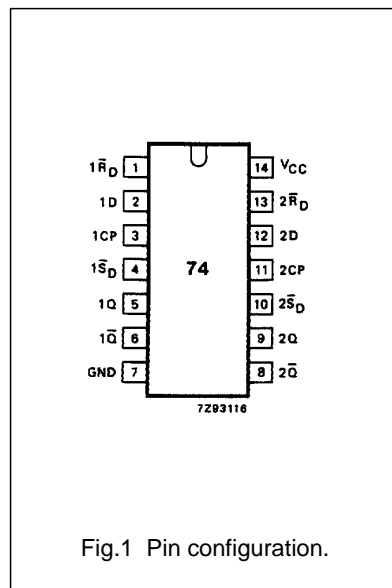

Dual D-type flip-flop with set and reset;
positive-edge trigger

74HC/HCT74

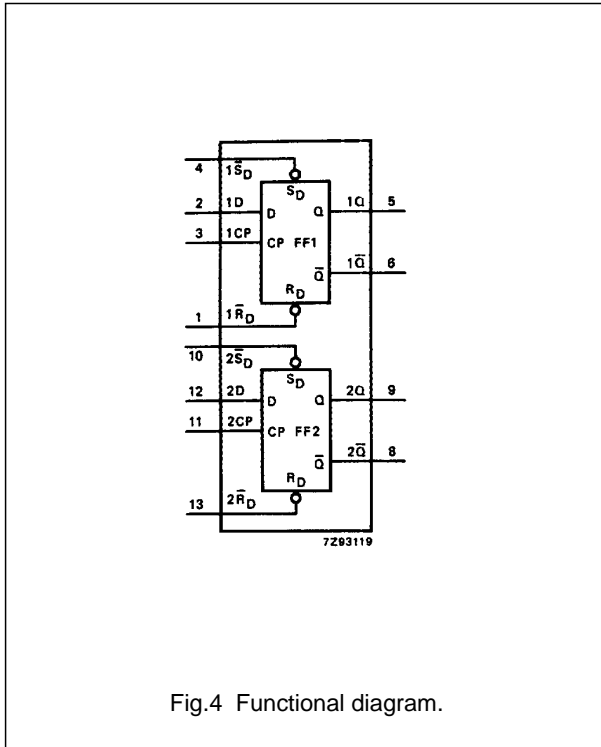

Fig.4 Functional diagram.

FUNCTION TABLE

INPUTS				OUTPUTS	
\bar{S}_D	\bar{R}_D	CP	D	Q	\bar{Q}
L	H	X	X	H	L
H	L	X	X	L	H
L	L	X	X	H	H

INPUTS				OUTPUTS	
\bar{S}_D	\bar{R}_D	CP	D	Q_{n+1}	\bar{Q}_{n+1}
H	H	↑	L	L	H
H	H	↑	H	H	L

Note

- 1. H = HIGH voltage level
- L = LOW voltage level
- X = don't care
- ↑ = LOW-to-HIGH CP transition
- Q_{n+1} = state after the next LOW-to-HIGH CP transition

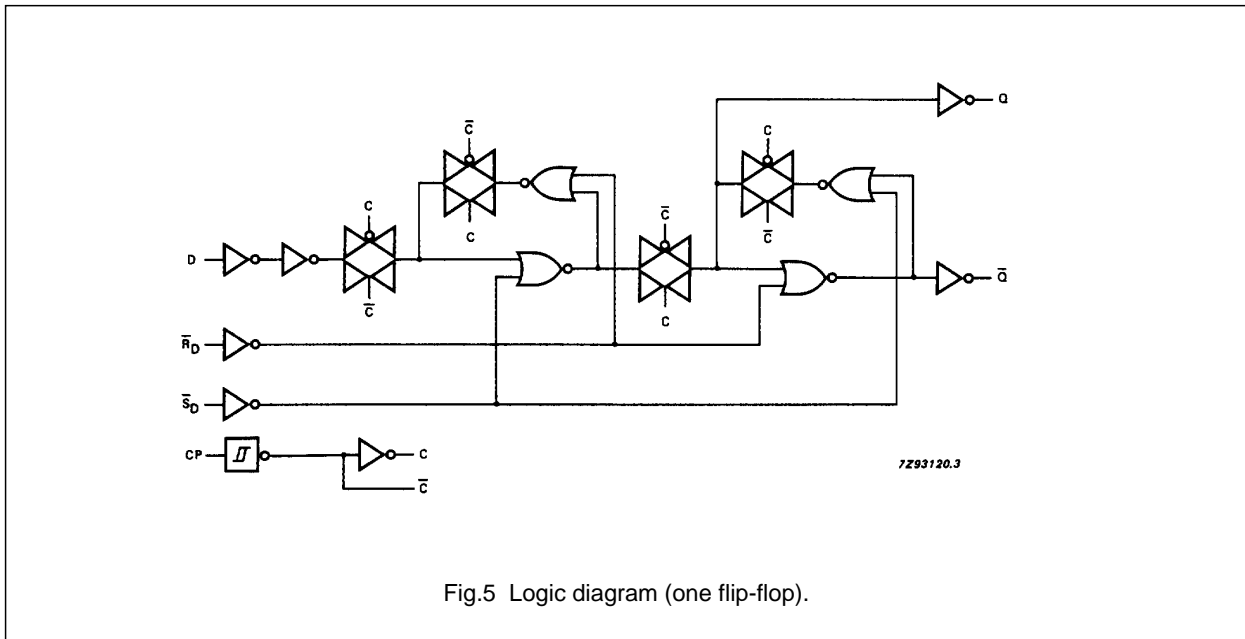

Fig.5 Logic diagram (one flip-flop).

Dual D-type flip-flop with set and reset; positive-edge trigger

74HC/HCT74

DC CHARACTERISTICS FOR 74HC

For the DC characteristics see *"74HC/HCT/HCU/HCMOS Logic Family Specifications"*.

Output capability: standard

I_{CC} category: flip-flops

AC CHARACTERISTICS

GND = 0 V; t_r = t_f = 6 ns; C_L = 50 pF

SYMBOL	PARAMETER	T _{amb} (°C)						UNIT	TEST CONDITIONS		
		74HC							V _{CC} (V)	WAVEFORMS	
		+25			-40 to +85		-40 to +125				
		min.	typ.	max.	min.	max.	min.				max.
t _{PHL} / t _{PLH}	propagation delay nCP to nQ, nQ̄		47 17 14	175 35 30		220 44 37		265 53 45	ns	2.0 4.5 6.0	Fig.6
t _{PHL} / t _{PLH}	propagation delay nS _D to nQ, nQ̄		50 18 14	200 40 34		250 50 43		300 60 51	ns	2.0 4.5 6.0	Fig.7
t _{PHL} / t _{PLH}	propagation delay nR _D to nQ, nQ̄		52 19 15	200 40 34		250 50 43		300 60 51	ns	2.0 4.5 6.0	Fig.7
t _{THL} / t _{TLH}	output transition time		19 7 6	75 15 13		95 19 16		110 22 19	ns	2.0 4.5 6.0	Fig.6
t _w	clock pulse width HIGH or LOW	80 16 14	19 7 6		100 20 17		120 24 20		ns	2.0 4.5 6.0	Fig.6
t _w	set or reset pulse width LOW	80 16 14	19 7 6		100 20 17		120 24 20		ns	2.0 4.5 6.0	Fig.7
t _{rem}	removal time set or reset	30 6 5	3 1 1		40 8 7		45 9 8		ns	2.0 4.5 6.0	Fig.7
t _{su}	set-up time nD to nCP	60 12 10	6 2 2		75 15 13		90 18 15		ns	2.0 4.5 6.0	Fig.6
t _h	hold time nCP to nD	3 3 3	-6 -2 -2		3 3 3		3 3 3		ns	2.0 4.5 6.0	Fig.6
f _{max}	maximum clock pulse frequency	6.0 30 35	23 69 82		4.8 24 28		4.0 20 24		MHz	2.0 4.5 6.0	Fig.6

Dual D-type flip-flop with set and reset; positive-edge trigger

74HC/HCT74

DC CHARACTERISTICS FOR 74HCT

For the DC characteristics see *"74HC/HCT/HCU/HCMOS Logic Family Specifications"*.

Output capability: standard

I_{CC} category: flip-flops

Note to HCT types

The value of additional quiescent supply current (ΔI_{CC}) for a unit load of 1 is given in the family specifications. To determine ΔI_{CC} per input, multiply this value by the unit load coefficient shown in the table below.

INPUT	UNIT LOAD COEFFICIENT
nD	0.70
n \bar{R}_D	0.70
n \bar{S}_D	0.80
nCP	0.80

AC CHARACTERISTICS FOR 74HCT

GND = 0 V; t_r = t_f = 6 ns; C_L = 50 pF

SYMBOL	PARAMETER	T _{amb} (°C)								UNIT	TEST CONDITIONS	
		74HCT									V _{CC} (V)	WAVEFORMS
		+25			-40 to +85		-40 to +125					
		min.	typ.	max.	min.	max.	min.	max.				
t _{PHL} / t _{PLH}	propagation delay nCP to nQ, n \bar{Q}		18	35		44		53	ns	4.5	Fig.6	
t _{PHL} / t _{PLH}	propagation delay n \bar{S}_D to nQ, n \bar{Q}		23	40		50		60	ns	4.5	Fig.7	
t _{PHL} / t _{PLH}	propagation delay n \bar{R}_D to nQ, n \bar{Q}		24	40		50		60	ns	4.5	Fig.7	
t _{THL} / t _{TLH}	output transition time		7	15		19		22	ns	4.5	Fig.6	
t _W	clock pulse width HIGH or LOW	18	9		23		27		ns	4.5	Fig.6	
t _W	set or reset pulse width LOW	16	9		20		24		ns	4.5	Fig.7	
t _{rem}	removal time set or reset	6	1		8		9		ns	4.5	Fig.7	
t _{su}	set-up time nD to nCP	12	5		15		18		ns	4.5	Fig.6	
t _h	hold time nCP to nD	3	-3		3		3		ns	4.5	Fig.6	
f _{max}	maximum clock pulse frequency	27	54		22		18		MHz	4.5	Fig.6	

Dual D-type flip-flop with set and reset;
positive-edge trigger

74HC/HCT74

AC WAVEFORMS

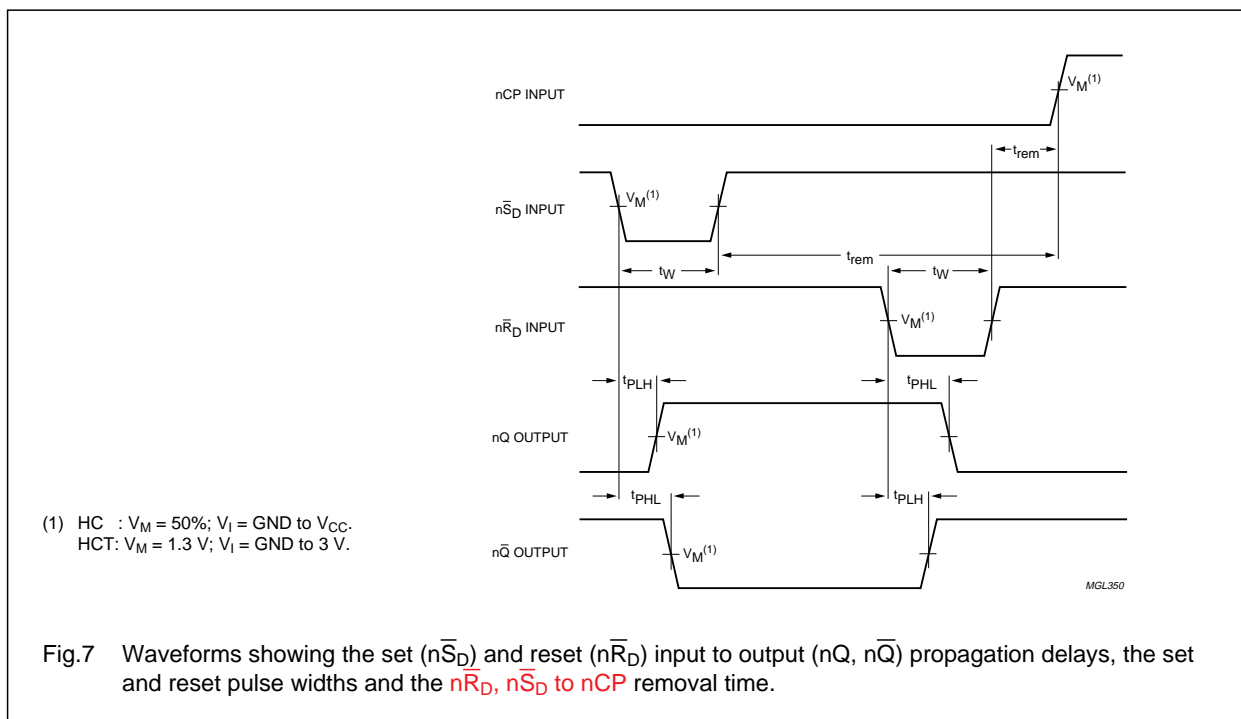
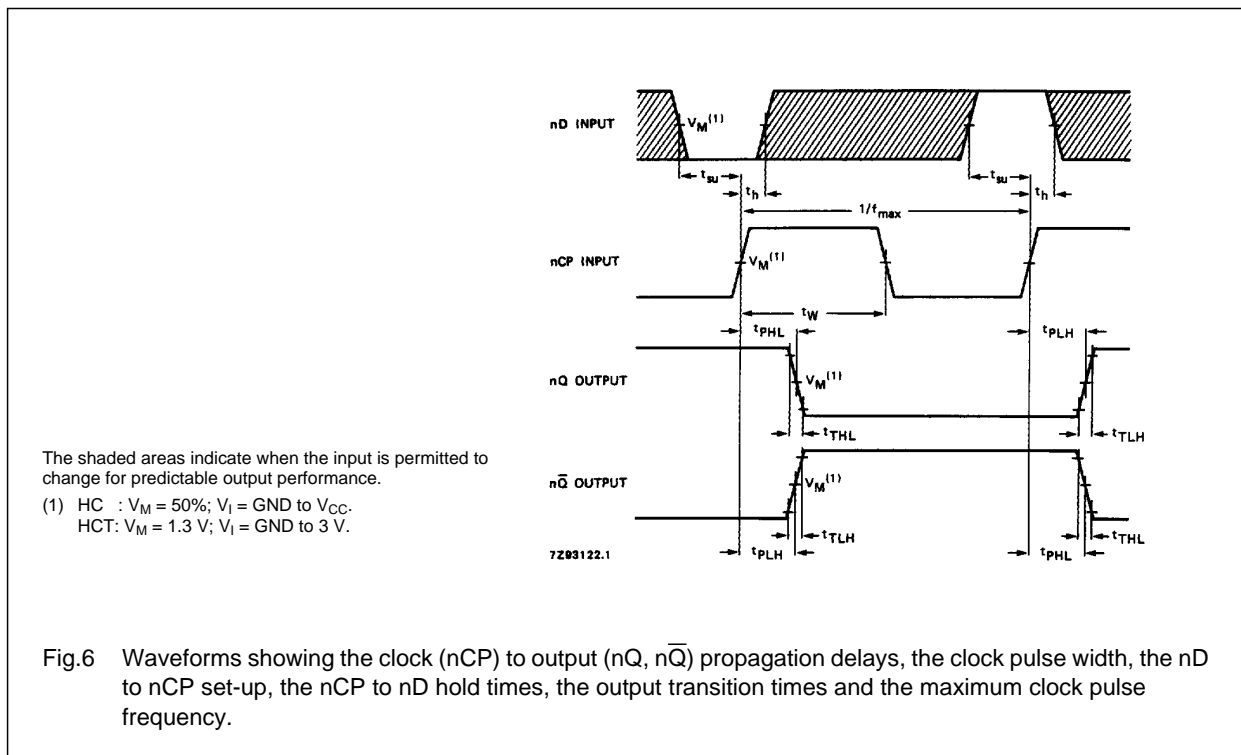

Dual D-type flip-flop with set and reset;
positive-edge trigger

74HC/HCT74

PACKAGE OUTLINES

DIP14: plastic dual in-line package; 14 leads (300 mil)

SOT27-1

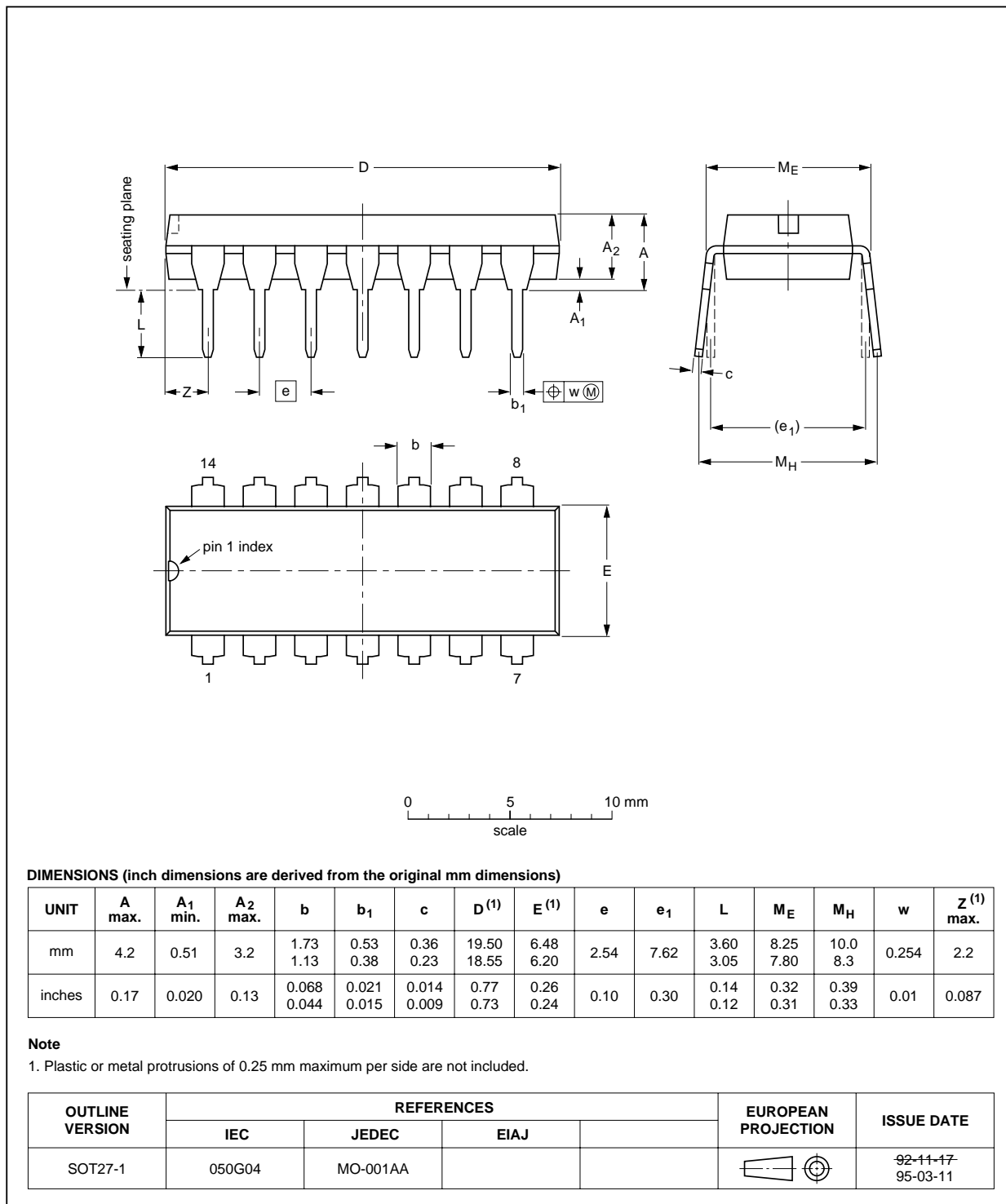

Dual D-type flip-flop with set and reset;
positive-edge trigger

74HC/HCT74

SO14: plastic small outline package; 14 leads; body width 3.9 mm

SOT108-1

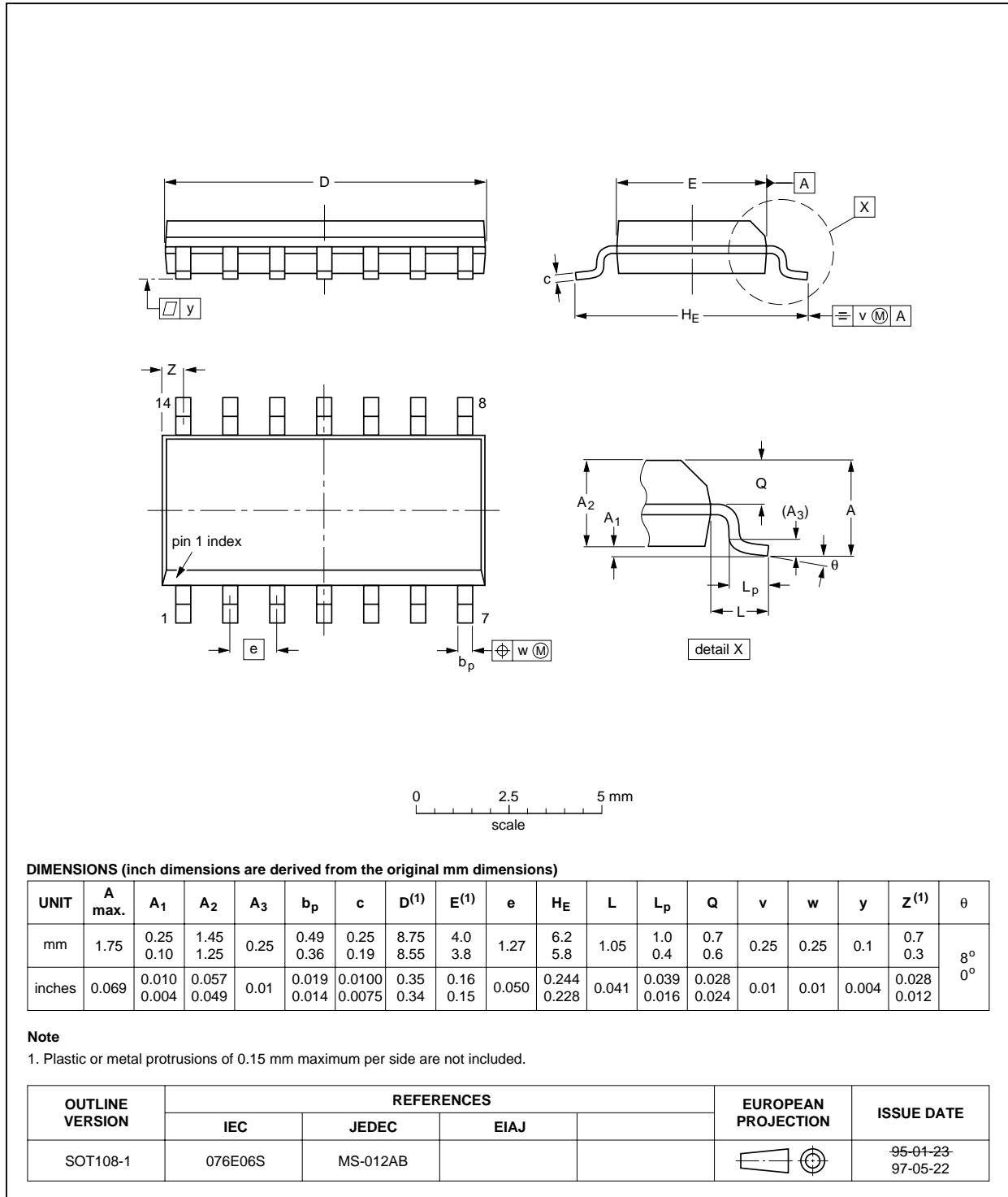

Dual D-type flip-flop with set and reset;
positive-edge trigger

74HC/HCT74

SSOP14: plastic shrink small outline package; 14 leads; body width 5.3 mm

SOT337-1

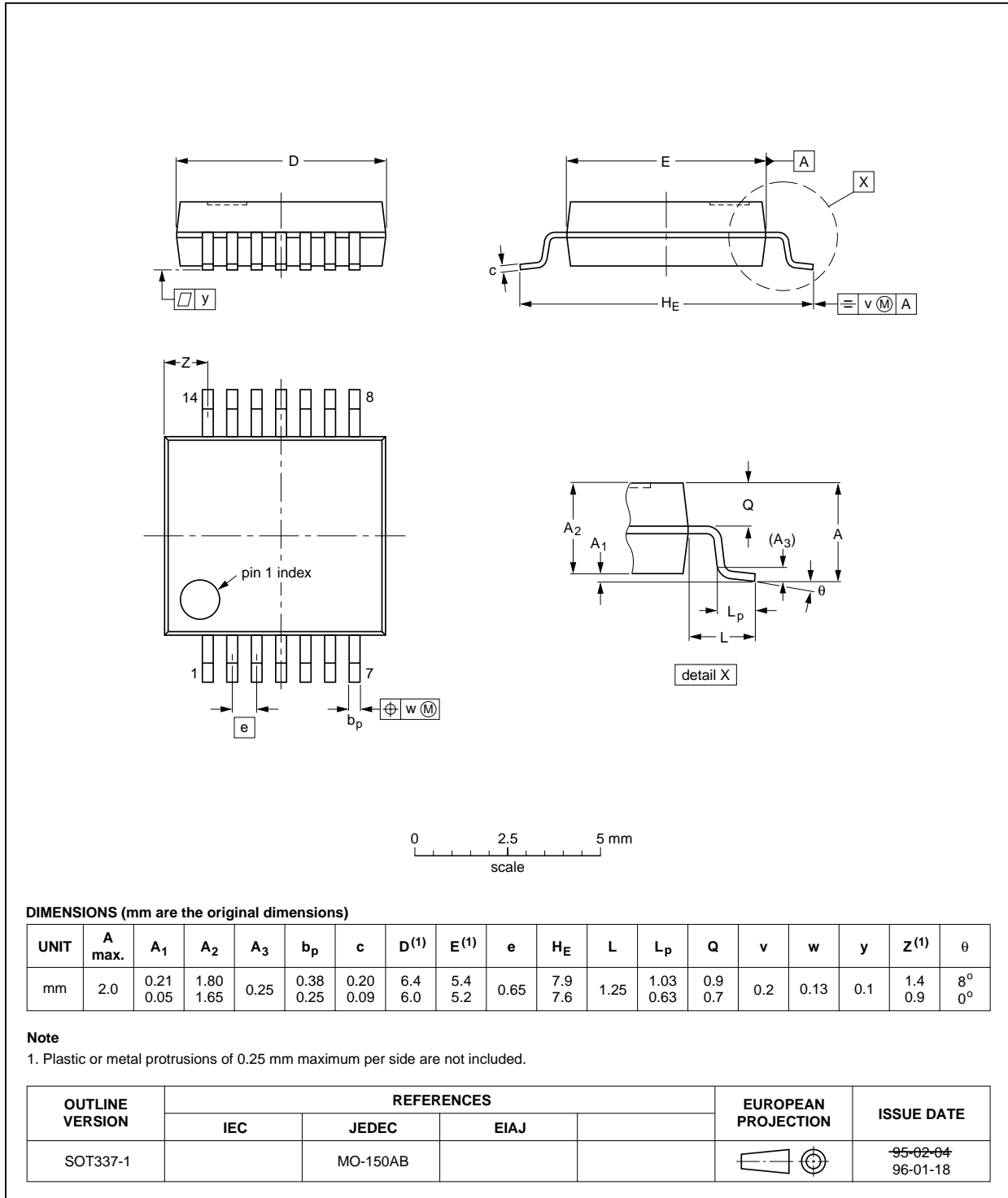

Dual D-type flip-flop with set and reset;
positive-edge trigger

74HC/HCT74

TSSOP14: plastic thin shrink small outline package; 14 leads; body width 4.4 mm

SOT402-1

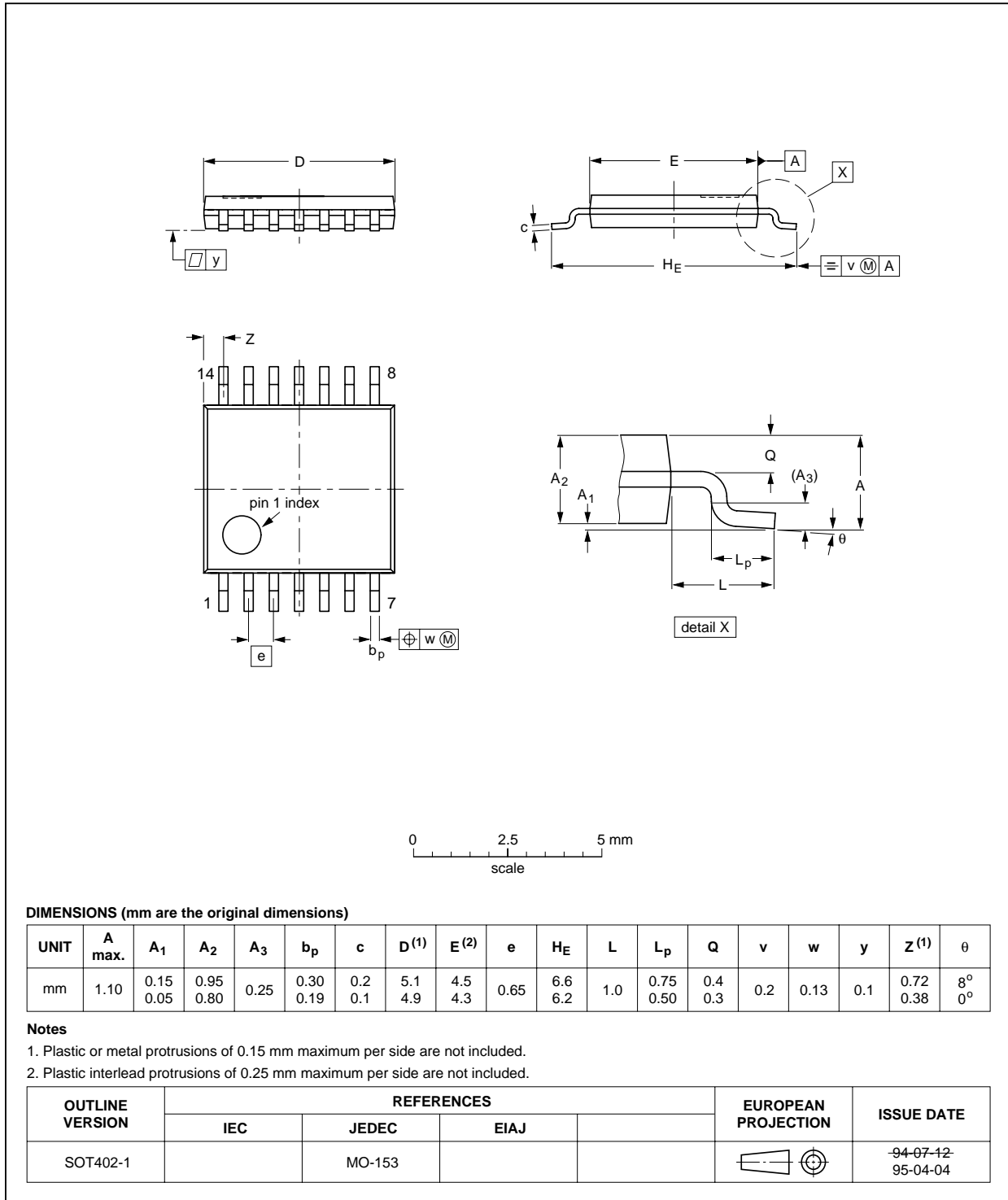

Dual D-type flip-flop with set and reset; positive-edge trigger

74HC/HCT74

SOLDERING

Introduction

There is no soldering method that is ideal for all IC packages. Wave soldering is often preferred when through-hole and surface mounted components are mixed on one printed-circuit board. However, wave soldering is not always suitable for surface mounted ICs, or for printed-circuits with high population densities. In these situations reflow soldering is often used.

This text gives a very brief insight to a complex technology. A more in-depth account of soldering ICs can be found in our "IC Package Databook" (order code 9398 652 90011).

DIP

SOLDERING BY DIPPING OR BY WAVE

The maximum permissible temperature of the solder is 260 °C; solder at this temperature must not be in contact with the joint for more than 5 seconds. The total contact time of successive solder waves must not exceed 5 seconds.

The device may be mounted up to the seating plane, but the temperature of the plastic body must not exceed the specified maximum storage temperature ($T_{stg\ max}$). If the printed-circuit board has been pre-heated, forced cooling may be necessary immediately after soldering to keep the temperature within the permissible limit.

REPAIRING SOLDERED JOINTS

Apply a low voltage soldering iron (less than 24 V) to the lead(s) of the package, below the seating plane or not more than 2 mm above it. If the temperature of the soldering iron bit is less than 300 °C it may remain in contact for up to 10 seconds. If the bit temperature is between 300 and 400 °C, contact may be up to 5 seconds.

SO, SSOP and TSSOP

REFLOW SOLDERING

Reflow soldering techniques are suitable for all SO, SSOP and TSSOP packages.

Reflow soldering requires solder paste (a suspension of fine solder particles, flux and binding agent) to be applied to the printed-circuit board by screen printing, stencilling or pressure-syringe dispensing before package placement.

Several techniques exist for reflowing; for example, thermal conduction by heated belt. Dwell times vary between 50 and 300 seconds depending on heating method.

Typical reflow temperatures range from 215 to 250 °C. Preheating is necessary to dry the paste and evaporate the binding agent. Preheating duration: 45 minutes at 45 °C.

WAVE SOLDERING

Wave soldering can be used for all SO packages. Wave soldering is **not** recommended for SSOP and TSSOP packages, because of the likelihood of solder bridging due to closely-spaced leads and the possibility of incomplete solder penetration in multi-lead devices.

If wave soldering is used - **and cannot be avoided for SSOP and TSSOP packages** - the following conditions must be observed:

- A double-wave (a turbulent wave with high upward pressure followed by a smooth laminar wave) soldering technique should be used.
- The longitudinal axis of the package footprint must be parallel to the solder flow and must incorporate solder thieves at the downstream end.

Even with these conditions:

- **Only consider wave soldering SSOP packages that have a body width of 4.4 mm, that is SSOP16 (SOT369-1) or SSOP20 (SOT266-1).**
- **Do not consider wave soldering TSSOP packages with 48 leads or more, that is TSSOP48 (SOT362-1) and TSSOP56 (SOT364-1).**

During placement and before soldering, the package must be fixed with a droplet of adhesive. The adhesive can be applied by screen printing, pin transfer or syringe dispensing. The package can be soldered after the adhesive is cured.

Maximum permissible solder temperature is 260 °C, and maximum duration of package immersion in solder is 10 seconds, if cooled to less than 150 °C within 6 seconds. Typical dwell time is 4 seconds at 250 °C.

A mildly-activated flux will eliminate the need for removal of corrosive residues in most applications.

REPAIRING SOLDERED JOINTS

Fix the component by first soldering two diagonally-opposite end leads. Use only a low voltage soldering iron (less than 24 V) applied to the flat part of the lead. Contact time must be limited to 10 seconds at up to 300 °C. When using a dedicated tool, all other leads can be soldered in one operation within 2 to 5 seconds between 270 and 320 °C.

**Dual D-type flip-flop with set and reset;
positive-edge trigger**

74HC/HCT74**DEFINITIONS**

Data sheet status	
Objective specification	This data sheet contains target or goal specifications for product development.
Preliminary specification	This data sheet contains preliminary data; supplementary data may be published later.
Product specification	This data sheet contains final product specifications.
Limiting values	
Limiting values given are in accordance with the Absolute Maximum Rating System (IEC 134). Stress above one or more of the limiting values may cause permanent damage to the device. These are stress ratings only and operation of the device at these or at any other conditions above those given in the Characteristics sections of the specification is not implied. Exposure to limiting values for extended periods may affect device reliability.	
Application information	
Where application information is given, it is advisory and does not form part of the specification.	

LIFE SUPPORT APPLICATIONS

These products are not designed for use in life support appliances, devices, or systems where malfunction of these products can reasonably be expected to result in personal injury. Philips customers using or selling these products for use in such applications do so at their own risk and agree to fully indemnify Philips for any damages resulting from such improper use or sale.