

# DATA SHEET

For a complete data sheet, please also download:

- The IC04 LOCMOS HE4000B Logic Family Specifications HEF, HEC
- The IC04 LOCMOS HE4000B Logic Package Outlines/Information HEF, HEC

## **HEF4081B** **gates** Quadruple 2-input AND gate

Product specification  
File under Integrated Circuits, IC04

January 1995

# Quadruple 2-input AND gate

# HEF4081B gates

### DESCRIPTION

The HEF4081B provides the positive quadruple 2-input AND function. The outputs are fully buffered for highest noise immunity and pattern insensitivity of output impedance.

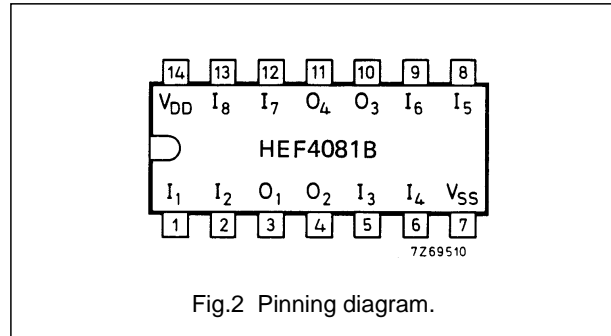
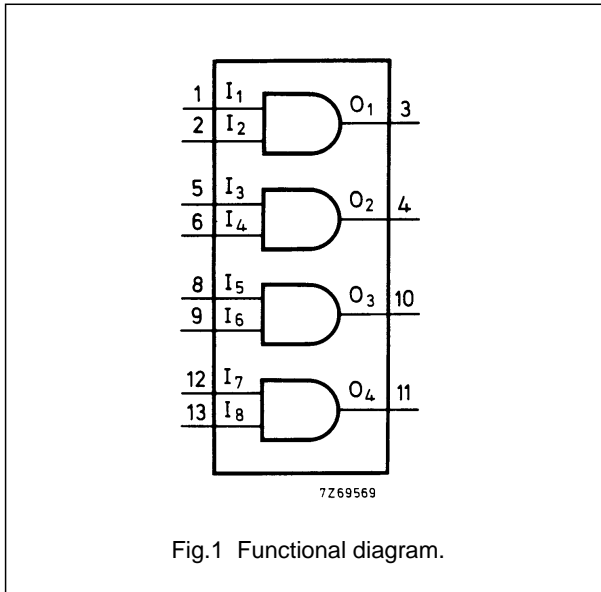

- HEF4081BP(N): 14-lead DIL; plastic (SOT27-1)
- HEF4081BD(F): 14-lead DIL; ceramic (cerdip) (SOT73)
- HEF4081BT(D): 14-lead SO; plastic (SOT108-1)
- ( ): Package Designator North America

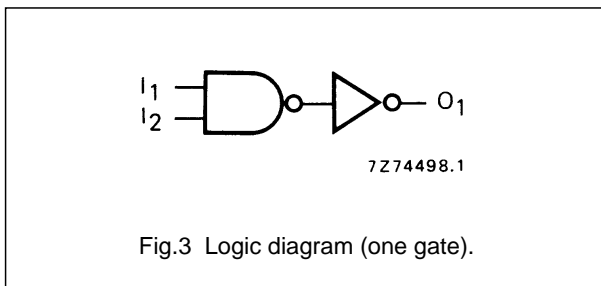

### FAMILY DATA, I<sub>DD</sub> LIMITS category GATES

See Family Specifications

# Quadruple 2-input AND gate

# HEF4081B gates

## AC CHARACTERISTICS

$V_{SS} = 0$  V;  $T_{amb} = 25$  °C;  $C_L = 50$  pF; input transition times  $\leq 20$  ns

	$V_{DD}$ V	SYMBOL	TYP.	MAX.		TYPICAL EXTRAPOLATION FORMULA	
Propagation delays $I_n \rightarrow O_n$ HIGH to LOW	5	$t_{PHL}$	55	110	ns	28 ns + (0,55 ns/pF) $C_L$	
	10		25	50	ns	14 ns + (0,23 ns/pF) $C_L$	
	15		20	40	ns	12 ns + (0,16 ns/pF) $C_L$	
	LOW to HIGH	5	$t_{PLH}$	45	90	ns	18 ns + (0,55 ns/pF) $C_L$
		10		20	40	ns	9 ns + (0,23 ns/pF) $C_L$
		15		15	30	ns	7 ns + (0,16 ns/pF) $C_L$
Output transition times HIGH to LOW	5	$t_{THL}$	60	120	ns	10 ns + (1,0 ns/pF) $C_L$	
	10		30	60	ns	9 ns + (0,42 ns/pF) $C_L$	
	15		20	40	ns	6 ns + (0,28 ns/pF) $C_L$	
	LOW to HIGH	5	$t_{TLH}$	60	120	ns	10 ns + (1,0 ns/pF) $C_L$
		10		30	60	ns	9 ns + (0,42 ns/pF) $C_L$
		15		20	40	ns	6 ns + (0,28 ns/pF) $C_L$

	$V_{DD}$ V	TYPICAL FORMULA FOR P ( $\mu$ W)	
Dynamic power dissipation per package (P)	5	$450 f_i + \sum (f_o C_L) \times V_{DD}^2$	where $f_i$ = input freq. (MHz) $f_o$ = output freq. (MHz) $C_L$ = load capacitance (pF) $\sum (f_o C_L)$ = sum of outputs $V_{DD}$ = supply voltage (V)
	10	$2\,900 f_i + \sum (f_o C_L) \times V_{DD}^2$	
	15	$11\,700 f_i + \sum (f_o C_L) \times V_{DD}^2$	