

# DATA SHEET

For a complete data sheet, please also download:

- The IC04 LOCMOS HE4000B Logic Family Specifications HEF, HEC
- The IC04 LOCMOS HE4000B Logic Package Outlines/Information HEF, HEC

## **HEF4053B**

### **MSI**

Triple 2-channel analogue  
multiplexer/demultiplexer

Product specification  
File under Integrated Circuits, IC04

January 1995

# Triple 2-channel analogue multiplexer/demultiplexer

**HEF4053B**  
**MSI**

## DESCRIPTION

The HEF4053B is a triple 2-channel analogue multiplexer/demultiplexer with a common enable input ( $\bar{E}$ ). Each multiplexer/demultiplexer has two independent inputs/outputs ( $Y_0$  and  $Y_1$ ), a common input/output ( $Z$ ), and select inputs ( $S_n$ ). Each also contains two-bidirectional analogue switches, each with one side connected to an independent input/output ( $Y_0$  and  $Y_1$ ) and the other side connected to a common input/output ( $Z$ ).

With  $\bar{E}$  LOW, one of the two switches is selected (low impedance ON-state) by  $S_n$ . With  $\bar{E}$  HIGH, all switches are in the high impedance OFF-state, independent of  $S_A$  to  $S_C$ .

$V_{DD}$  and  $V_{SS}$  are the supply voltage connections for the digital control inputs ( $S_A$  to  $S_C$  and  $\bar{E}$ ).

The  $V_{DD}$  to  $V_{SS}$  range is 3 to 15 V. The analogue inputs/outputs ( $Y_0$ ,  $Y_1$  and  $Z$ ) can swing between  $V_{DD}$  as a positive limit and  $V_{EE}$  as a negative limit.  $V_{DD}-V_{EE}$  may not exceed 15 V.

For operation as a digital multiplexer/demultiplexer,  $V_{EE}$  is connected to  $V_{SS}$  (typically ground).

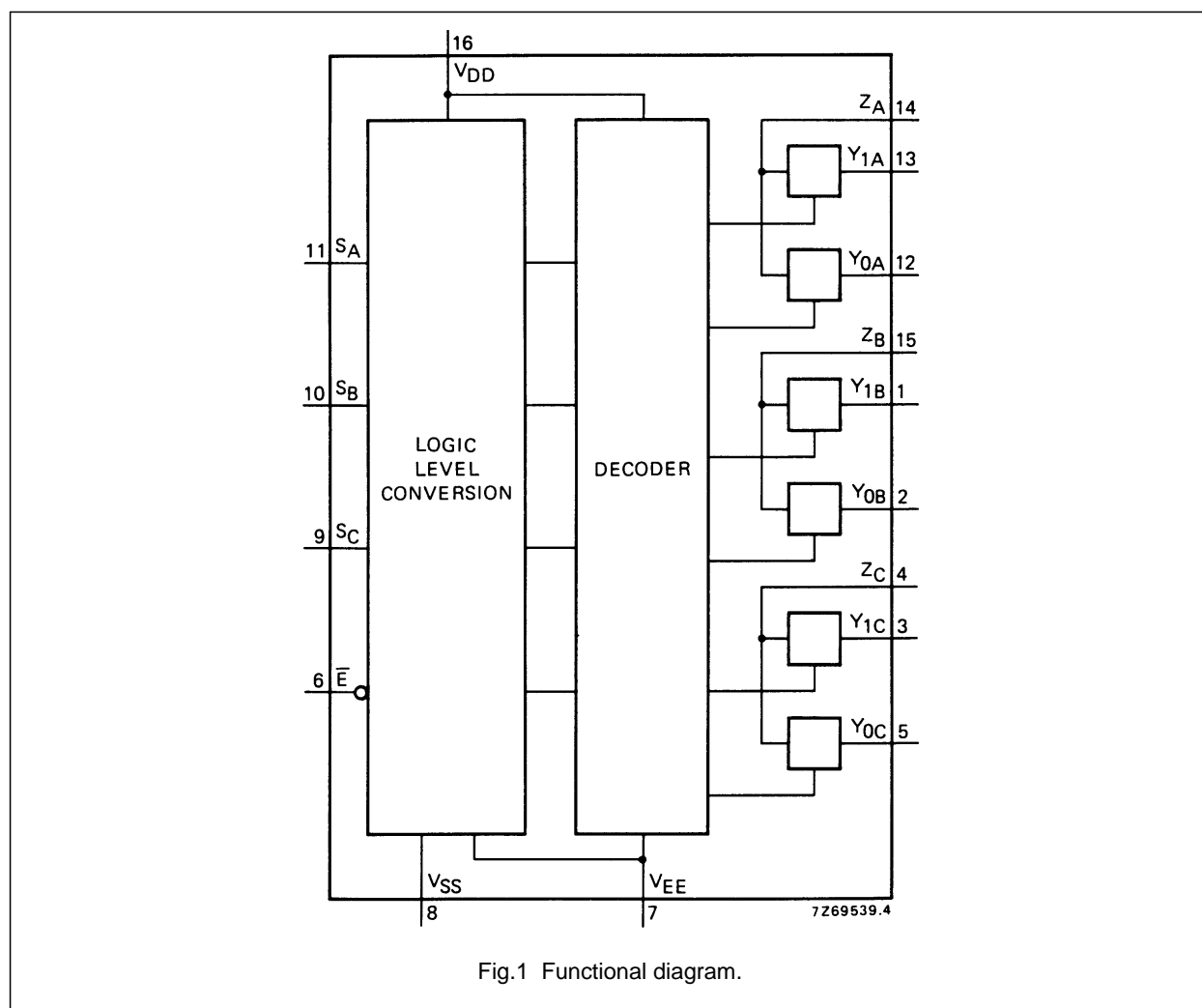

Fig.1 Functional diagram.

## FAMILY DATA, $I_{DD}$ LIMITS category MSI

See Family Specifications

Triple 2-channel analogue  
multiplexer/demultiplexer

HEF4053B  
MSI

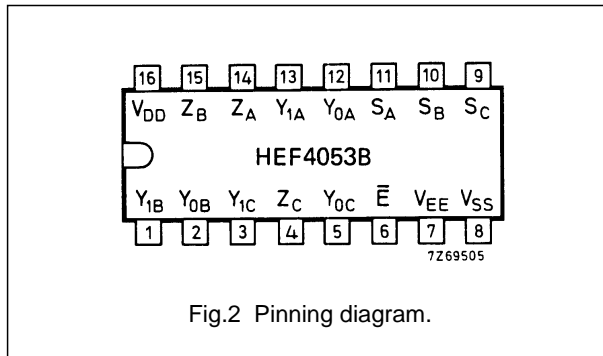

Fig.2 Pinning diagram.

**PINNING**

Y<sub>0A</sub> to Y<sub>0C</sub> independent inputs/outputs  
 Y<sub>1A</sub> to Y<sub>1C</sub> independent inputs/outputs  
 S<sub>A</sub> to S<sub>C</sub> select inputs  
 $\bar{E}$  enable input (active LOW)  
 Z<sub>A</sub> to Z<sub>C</sub> common inputs/outputs

**FUNCTION TABLE**

INPUTS		CHANNEL ON
$\bar{E}$	S <sub>n</sub>	
L	L	Y <sub>0n</sub> -Z <sub>n</sub>
L	H	Y <sub>1n</sub> -Z <sub>n</sub>
H	X	none

**Notes**

- H = HIGH state (the more positive voltage)  
 L = LOW state (the less positive voltage)  
 X = state is immaterial

HEF4053BP(N): 16-lead DIL; plastic (SOT38-1)  
 HEF4053BD(F): 16-lead DIL; ceramic (cerdip) (SOT74)  
 HEF4053BT(D): 16-lead SO; plastic (SOT109-1)  
 ( ): Package Designator North America

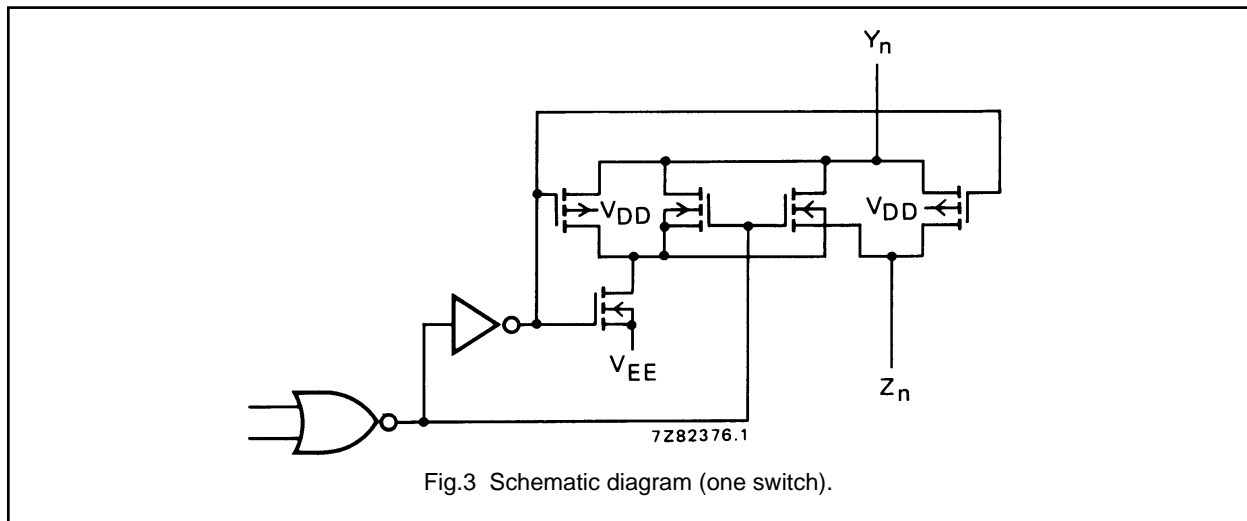

Fig.3 Schematic diagram (one switch).

**RATINGS**

Limiting values in accordance with the Absolute Maximum System (IEC 134)

Supply voltage (with reference to V<sub>DD</sub>) V<sub>EE</sub> -18 to +0,5 V

**Note**

- To avoid drawing V<sub>DD</sub> current out of terminal Z, when switch current flows into terminals Y, the voltage drop across the bidirectional switch must not exceed 0,4 V. If the switch current flows into terminal Z, no V<sub>DD</sub> current will flow out of terminals Y, in this case there is no limit for the voltage drop across the switch, but the voltages at Y and Z may not exceed V<sub>DD</sub> or V<sub>EE</sub>.

Triple 2-channel analogue  
multiplexer/demultiplexer

HEF4053B  
MSI

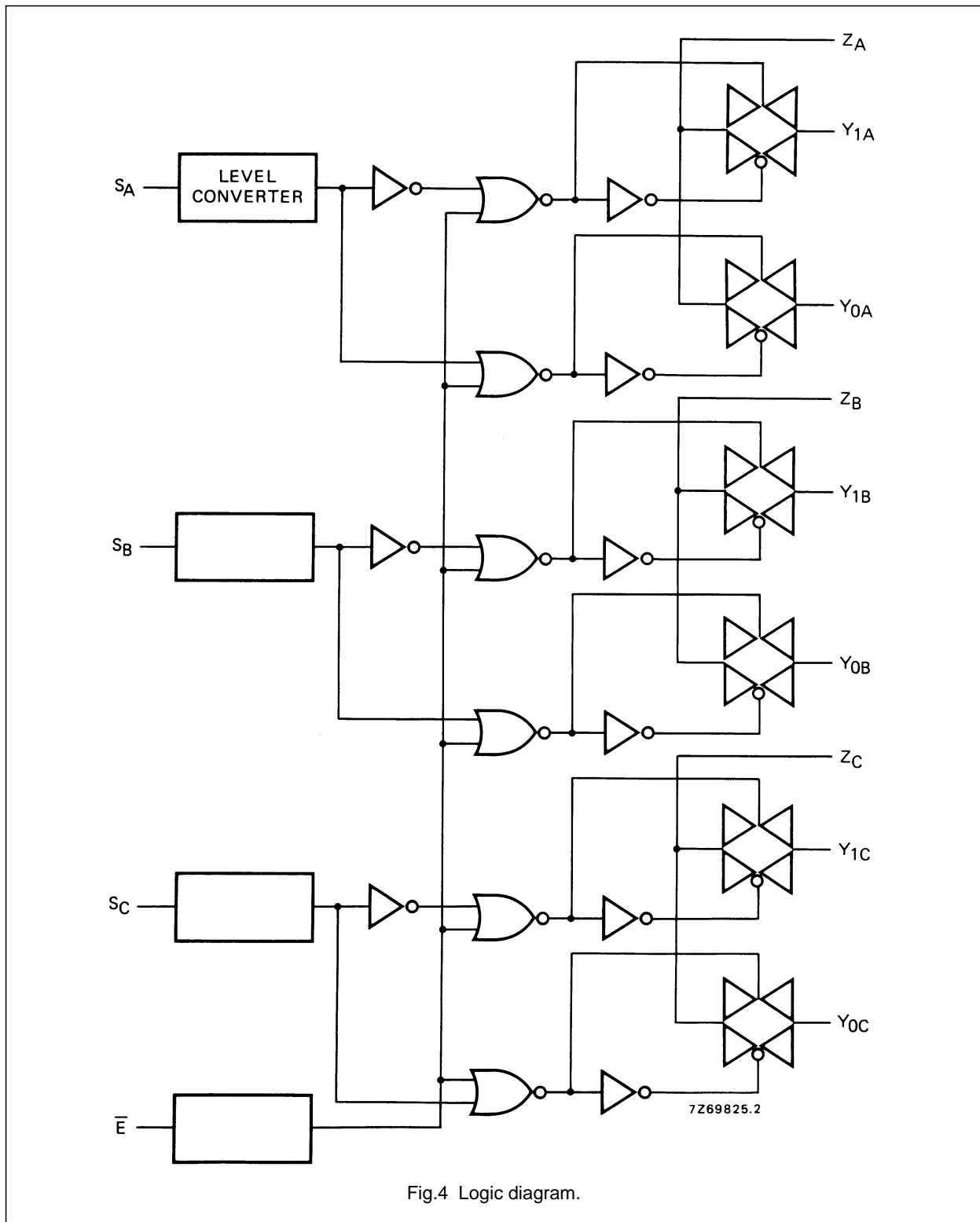

Fig.4 Logic diagram.

# Triple 2-channel analogue multiplexer/demultiplexer

# HEF4053B MSI

## DC CHARACTERISTICS

 $T_{amb} = 25\text{ }^{\circ}\text{C}$ 

	$V_{DD}-V_{EE}$ V	SYMBOL	TYP.	MAX.		CONDITIONS
ON resistance	5	$R_{ON}$	350	2500	$\Omega$	$V_{is} = 0$ to $V_{DD}-V_{EE}$ see Fig.6
	10		80	245	$\Omega$	
	15		60	175	$\Omega$	
ON resistance	5	$R_{ON}$	115	340	$\Omega$	$V_{is} = 0$ see Fig.6
	10		50	160	$\Omega$	
	15		40	115	$\Omega$	
ON resistance	5	$R_{ON}$	120	365	$\Omega$	$V_{is} = V_{DD}-V_{EE}$ see Fig.6
	10		65	200	$\Omega$	
	15		50	155	$\Omega$	
' $\Delta$ ' ON resistance between any two channels	5	$\Delta R_{ON}$	25	-	$\Omega$	$V_{is} = 0$ to $V_{DD}-V_{EE}$ see Fig.6
	10		10	-	$\Omega$	
	15		5	-	$\Omega$	
OFF-state leakage current, all channels OFF	5	$I_{OZZ}$	-	-	nA	$\bar{E}$ at $V_{DD}$
	10		-	-	nA	
	15		-	1000	nA	
OFF-state leakage current, any channel	5	$I_{OZY}$	-	-	nA	$\bar{E}$ at $V_{SS}$
	10		-	-	nA	
	15		-	200	nA	

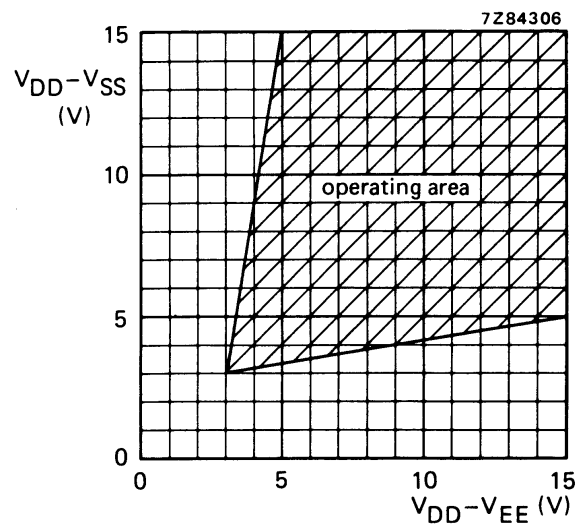

Fig.5 Operating area as a function of the supply voltages.

Triple 2-channel analogue  
multiplexer/demultiplexer

HEF4053B  
MSI

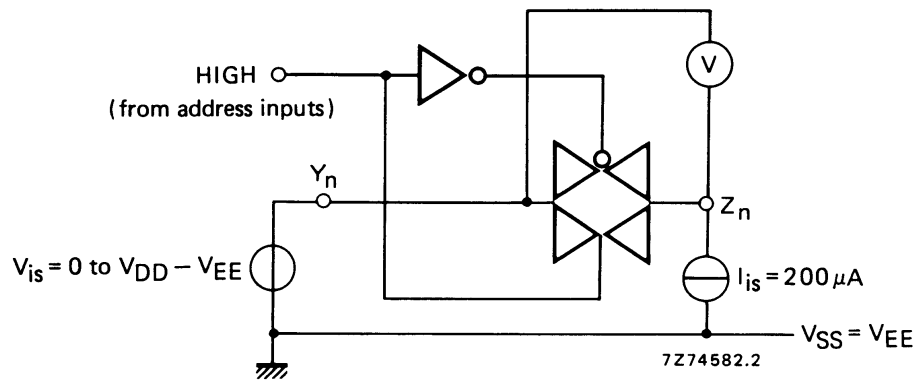
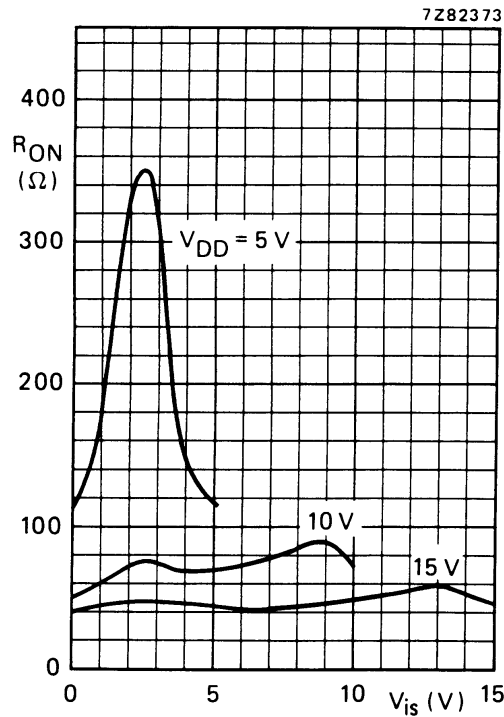

Fig.6 Test set-up for measuring  $R_{ON}$ .



$I_{is} = 200 \mu A$   
 $V_{SS} = V_{EE} = 0 V$

Fig.7 Typical  $R_{ON}$  as a function of input voltage.

# Triple 2-channel analogue multiplexer/demultiplexer

# HEF4053B MSI

## AC CHARACTERISTICS

 $V_{EE} = V_{SS} = 0 \text{ V}; T_{amb} = 25 \text{ }^\circ\text{C}; \text{input transition times} \leq 20 \text{ ns}$ 

	$V_{DD}$ V	TYPICAL FORMULA FOR P ( $\mu\text{W}$ )	
Dynamic power dissipation per package (P)	5 10 15	$2\,500 f_i + \sum(f_o C_L) \times V_{DD}^2$ $11\,500 f_i + \sum(f_o C_L) \times V_{DD}^2$ $29\,000 f_i + \sum(f_o C_L) \times V_{DD}^2$	where $f_i$ = input freq. (MHz) $f_o$ = output freq. (MHz) $C_L$ = load capacitance (pF) $\sum(f_o C_L)$ = sum of outputs $V_{DD}$ = supply voltage (V)

## AC CHARACTERISTICS

 $V_{EE} = V_{SS} = 0 \text{ V}; T_{amb} = 25 \text{ }^\circ\text{C}; \text{input transition times} \leq 20 \text{ ns}$ 

	$V_{DD}$ V	SYMBOL	TYP.	MAX.			
Propagation delays $V_{is} \rightarrow V_{os}$ HIGH to LOW	5	$t_{PHL}$	10	20	ns	note 1	
	10		5	10	ns		
	15		5	10	ns		
	LOW to HIGH	5	$t_{PLH}$	15	30	ns	note 1
		10		5	10	ns	
		15		5	10	ns	
$S_n \rightarrow V_{os}$ HIGH to LOW	5	$t_{PHL}$	200	400	ns	note 2	
	10		85	170	ns		
	15		65	130	ns		
	LOW to HIGH	5	$t_{PLH}$	275	555	ns	note 2
		10		100	200	ns	
		15		65	130	ns	
Output disable times $\bar{E} \rightarrow V_{os}$ HIGH	5	$t_{PHZ}$	200	400	ns	note 3	
	10		115	230	ns		
	15		110	220	ns		
	LOW	5	$t_{PLZ}$	200	400	ns	note 3
		10		120	245	ns	
		15		110	215	ns	
Output enable times $\bar{E} \rightarrow V_{os}$ HIGH	5	$t_{PZH}$	260	525	ns	note 3	
	10		95	190	ns		
	15		65	130	ns		
	LOW	5	$t_{PZL}$	280	565	ns	note 3
		10		105	205	ns	
		15		70	140	ns	

# Triple 2-channel analogue multiplexer/demultiplexer

# HEF4053B MSI

	V <sub>DD</sub> V	SYMBOL	TYP.	MAX.	
Distortion, sine-wave response	5		0,25	%	note 4
	10		0,04	%	
	15		0,04	%	
Crosstalk between any two channels	5		–	MHz	note 5
	10		1	MHz	
	15		–	MHz	
Crosstalk; enable or address input to output	5		–	mV	note 6
	10		50	mV	
	15		–	mV	
OFF-state feed-through	5		–	MHz	note 7
	10		1	MHz	
	15		–	MHz	
ON-state frequency response	5		13	MHz	note 8
	10		40	MHz	
	15		70	MHz	

## Notes

V<sub>is</sub> is the input voltage at a Y or Z terminal, whichever is assigned as input.

V<sub>os</sub> is the output voltage at a Y or Z terminal, whichever is assigned as output.

- R<sub>L</sub> = 10 kΩ to V<sub>EE</sub>; C<sub>L</sub> = 50 pF to V<sub>EE</sub>;  $\bar{E} = V_{SS}$ ; V<sub>is</sub> = V<sub>DD</sub> (square-wave); see Fig.8.
- R<sub>L</sub> = 10 kΩ; C<sub>L</sub> = 50 pF to V<sub>EE</sub>;  $\bar{E} = V_{SS}$ ; S<sub>n</sub> = V<sub>DD</sub> (square-wave); V<sub>is</sub> = V<sub>DD</sub> and R<sub>L</sub> to V<sub>EE</sub> for t<sub>PLH</sub>; V<sub>is</sub> = V<sub>EE</sub> and R<sub>L</sub> to V<sub>DD</sub> for t<sub>PHL</sub>; see Fig.8.
- R<sub>L</sub> = 10 kΩ; C<sub>L</sub> = 50 pF to V<sub>EE</sub>;  $\bar{E} = V_{DD}$  (square-wave);  
V<sub>is</sub> = V<sub>DD</sub> and R<sub>L</sub> to V<sub>EE</sub> for t<sub>PHZ</sub> and t<sub>PZH</sub>;  
V<sub>is</sub> = V<sub>EE</sub> and R<sub>L</sub> to V<sub>DD</sub> for t<sub>PLZ</sub> and t<sub>PZL</sub>; see Fig.8.
- R<sub>L</sub> = 10 kΩ; C<sub>L</sub> = 15 pF; channel ON; V<sub>is</sub> = 1/2 V<sub>DD (p-p)</sub> (sine-wave, symmetrical about 1/2 V<sub>DD</sub>);  
f<sub>is</sub> = 1 kHz; see Fig.9.
- R<sub>L</sub> = 1 kΩ; V<sub>is</sub> = 1/2 V<sub>DD (p-p)</sub> (sine-wave, symmetrical about 1/2 V<sub>DD</sub>);  
 $20 \log \frac{V_{os}}{V_{is}} = -50 \text{ dB}$ ; see Fig. 10.
- R<sub>L</sub> = 10 kΩ to V<sub>EE</sub>; C<sub>L</sub> = 15 pF to V<sub>EE</sub>;  $\bar{E}$  or S<sub>n</sub> = V<sub>DD</sub> (square-wave); crosstalk is |V<sub>os</sub>| (peak value); see Fig.8.
- R<sub>L</sub> = 1 kΩ; C<sub>L</sub> = 5 pF; channel OFF; V<sub>is</sub> = 1/2 V<sub>DD (p-p)</sub> (sine-wave, symmetrical about 1/2 V<sub>DD</sub>);  
 $20 \log \frac{V_{os}}{V_{is}} = -50 \text{ dB}$ ; see Fig. 9.
- R<sub>L</sub> = 1 kΩ; C<sub>L</sub> = 5 pF; channel ON; V<sub>is</sub> = 1/2 V<sub>DD (p-p)</sub> (sine-wave, symmetrical about 1/2 V<sub>DD</sub>);  
 $20 \log \frac{V_{os}}{V_{is}} = -3 \text{ dB}$ ; see Fig. 9.



# Triple 2-channel analogue multiplexer/demultiplexer

# HEF4053B MSI

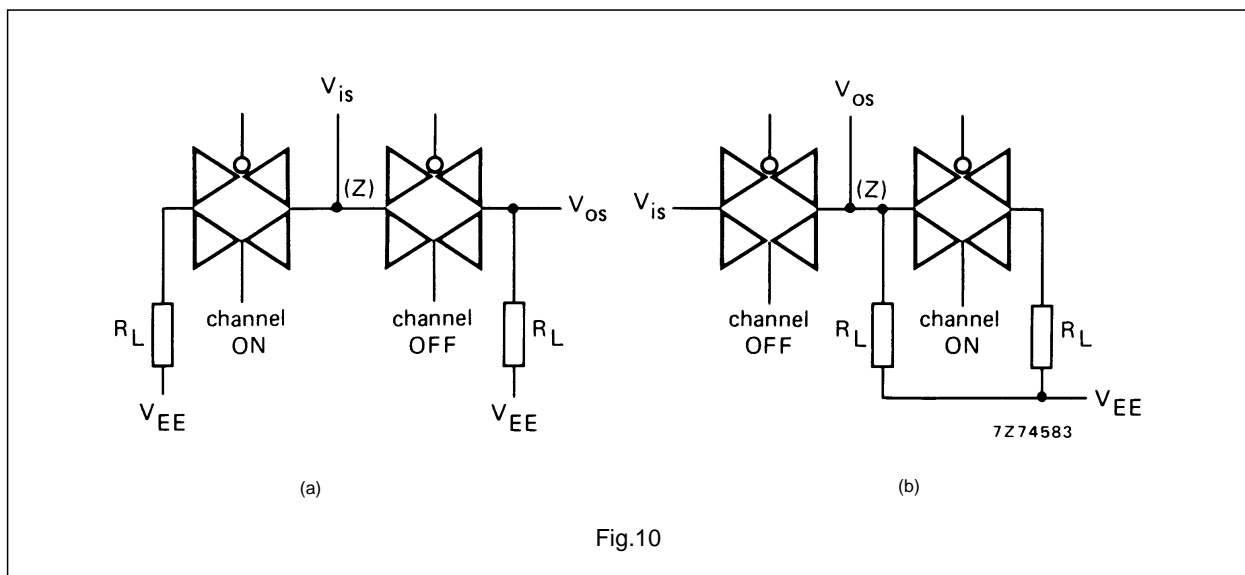
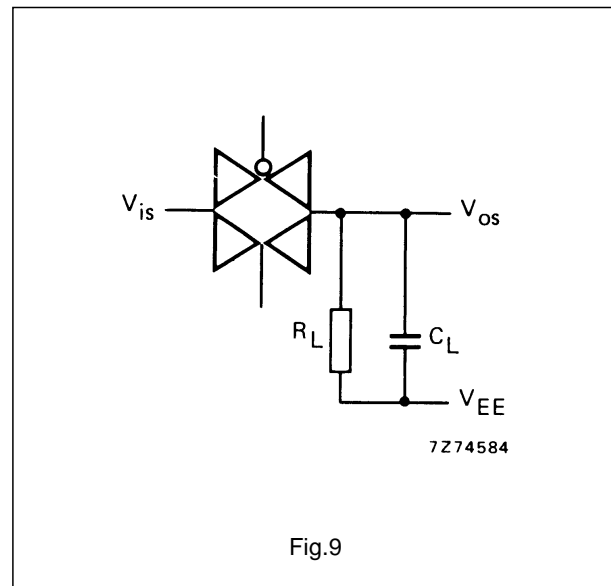
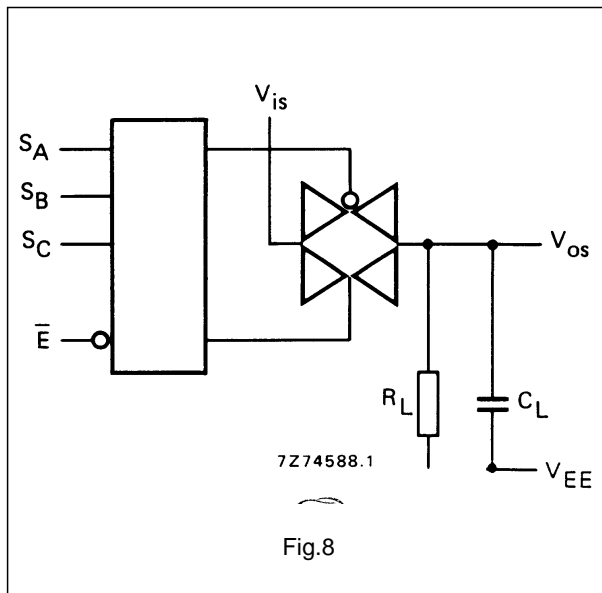

## APPLICATION INFORMATION

Some examples of applications for the HEF4053B are:

- Analogue multiplexing and demultiplexing.
- Digital multiplexing and demultiplexing.
- Signal gating.

## NOTE

If break before make is needed, then it is necessary to use the enable input.