

DATA SHEET

For a complete data sheet, please also download:

- The IC04 LOCMOS HE4000B Logic Family Specifications HEF, HEC
- The IC04 LOCMOS HE4000B Logic Package Outlines/Information HEF, HEC

HEF4040B

MSI

12-stage binary counter

Product specification
File under Integrated Circuits, IC04

January 1995

12-stage binary counter

HEF4040B MSI

DESCRIPTION

The HEF4040B is a 12-stage binary ripple counter with a clock input (\overline{CP}), an overriding asynchronous master reset input (MR) and twelve fully buffered outputs (O_0 to O_{11}). The counter advances on the HIGH to LOW transition of \overline{CP} . A HIGH on MR clears all counter stages and forces all outputs LOW, independent of \overline{CP} . Each counter stage is a static toggle flip-flop. Schmitt-trigger action in the clock input makes the circuit highly tolerant to slower clock rise and fall times.

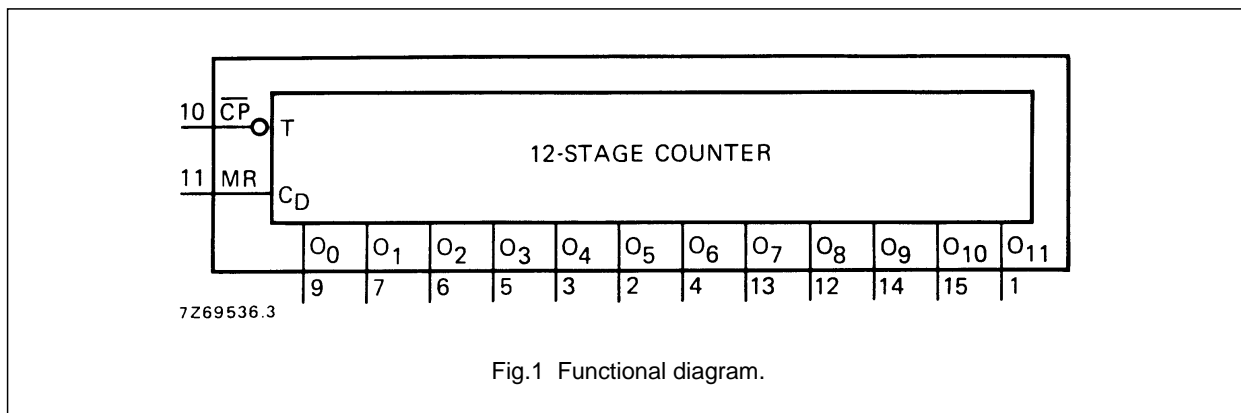

Fig.1 Functional diagram.

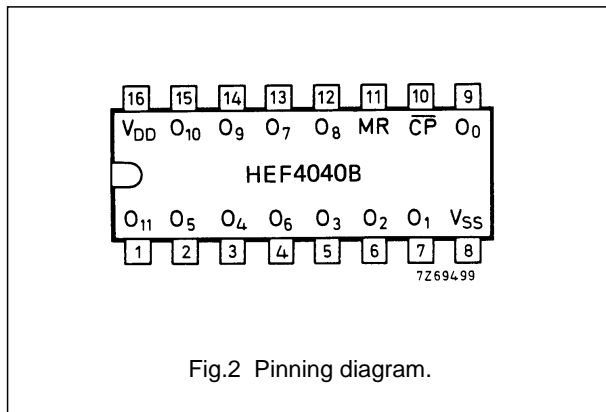

Fig.2 Pinning diagram.

PINNING

- \overline{CP} clock input (HIGH to LOW edge-triggered)
- MR master reset input (active HIGH)
- O_0 to O_{11} parallel outputs

APPLICATION INFORMATION

Some examples of applications for the HEF4040B are:

- Frequency dividing circuits
- Time delay circuits
- Control counters

FAMILY DATA, I_{DD} LIMITS category MSI

See Family Specifications

- HEF4040BP(N): 16-lead DIL; plastic (SOT38-1)
- HEF4040BD(F): 16-lead DIL; ceramic (cerdip) (SOT74)
- HEF4040BT(D): 16-lead SO; plastic (SOT109-1)
- (): Package Designator North America

12-stage binary counter

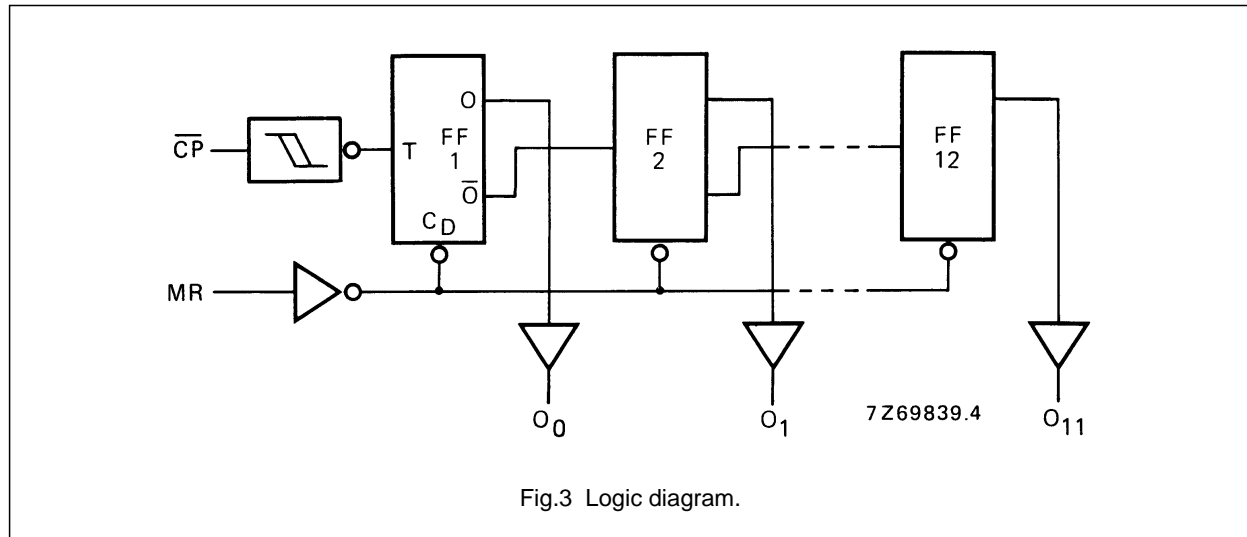
HEF4040B
MSI**AC CHARACTERISTICS** $V_{SS} = 0\text{ V}$; $T_{amb} = 25\text{ }^{\circ}\text{C}$; $C_L = 50\text{ pF}$; input transition times $\leq 20\text{ ns}$

	V_{DD} V	SYMBOL	MIN.	TYP.	MAX.	TYPICAL EXTRAPOLATION FORMULA		
Propagation delays $\overline{CP} \rightarrow O_0$ HIGH to LOW	5	t_{PHL}		105	210	ns	78 ns + (0,55 ns/pF) C_L	
	10		45	90	ns	34 ns + (0,23 ns/pF) C_L		
	15		35	70	ns	27 ns + (0,16 ns/pF) C_L		
	LOW to HIGH	5	t_{PLH}		85	170	ns	58 ns + (0,55 ns/pF) C_L
		10		40	80	ns	29 ns + (0,23 ns/pF) C_L	
		15		30	60	ns	22 ns + (0,16 ns/pF) C_L	
	$O_n \rightarrow O_{n+1}$ HIGH to LOW	5	t_{PHL}		35	70	ns	note 1 (0,55 ns/pF) C_L
		10		15	30	ns	note 1 (0,23 ns/pF) C_L	
		15		10	20	ns	note 1 (0,16 ns/pF) C_L	
LOW to HIGH		5	t_{PLH}		35	70	ns	note 1 (0,55 ns/pF) C_L
		10		15	30	ns	note 1 (0,23 ns/pF) C_L	
		15		10	20	ns	note 1 (0,16 ns/pF) C_L	
MR $\rightarrow O_n$ HIGH to LOW	5	t_{PHL}		90	180	ns	63 ns + (0,55 ns/pF) C_L	
	10		40	80	ns	29 ns + (0,23 ns/pF) C_L		
	15		30	60	ns	22 ns + (0,16 ns/pF) C_L		
Output transition times HIGH to LOW	5	t_{THL}		60	120	ns	10 ns + (1,0 ns/pF) C_L	
	10		30	60	ns	9 ns + (0,42 ns/pF) C_L		
	15		20	40	ns	6 ns + (0,28 ns/pF) C_L		
	LOW to HIGH	5	t_{TLH}		60	120	ns	10 ns + (1,0 ns/pF) C_L
		10		30	60	ns	9 ns + (0,42 ns/pF) C_L	
		15		20	40	ns	6 ns + (0,28 ns/pF) C_L	

12-stage binary counter

HEF4040B
MSI

	V _{DD} V	SYMBOL	MIN.	TYP.	MAX.	TYPICAL EXTRAPOLATION FORMULA
Minimum clock pulse width; HIGH	5	t _{WCPH}	50	25	ns	see also waveforms Fig.4
	10		30	15	ns	
	15		20	10	ns	
Minimum MR pulse width; HIGH	5	t _{WMRH}	40	20	ns	
	10		30	15	ns	
	15		20	10	ns	
Recovery time for MR	5	t _{RMR}	40	20	ns	
	10		30	15	ns	
	15		20	10	ns	
Maximum clock pulse frequency	5	f _{max}	10	20	MHz	
	10		15	30	MHz	
	15		25	50	MHz	

Note

- For other loads than 50 pF at the nth output, use the slope given.

	V _{DD} V	TYPICAL FORMULA FOR P (μW)	
Dynamic power dissipation per package (P)	5	$400 f_i + \sum (f_o C_L) \times V_{DD}^2$	where f _i = input freq. (MHz) f _o = output freq. (MHz) C _L = load cap. (pF) ∑ (f _o C _L) = sum of outputs V _{DD} = supply voltage (V)
	10	$2\,000 f_i + \sum (f_o C_L) \times V_{DD}^2$	
	15	$5\,200 f_i + \sum (f_o C_L) \times V_{DD}^2$	

12-stage binary counter

HEF4040B
MSI