

1.1 Scope.

This specification covers the detail requirements for a monolithic CMOS 10-bit multiplying digital-to-analog converter with an input buffer and a holding register, allowing direct interface with microprocessors.

1.2 Part Number.

The complete part number per Table 1 of this specification is as follows:

Device	Part Number
-1	AD7522SQ/883B
-2	AD7522TQ/883B
-3	AD7522UQ/883B

1.2.3 Case Outline.

See Appendix 1 of General Specification ADI-M-1000: package outline: Q-28

1.3 Absolute Maximum Ratings. ($T_A = 25^\circ\text{C}$ unless otherwise noted)

V_{REF} to GND	±25V
V_{DD} to DGND	0V, +17V
V_{CC} to GND	±17V
V_{CC} to V_{DD}	±0.4V
Output Voltage (Pins 6 and 7)	-0.3V, V_{DD}
Digital Input Voltage Range	V_{DD} to GND
Power Dissipation	
Up to +50°C	1000mW
Derates above +75°C	10mW/°C
Operating Temperature Range	-55°C to +125°C
Storage Temperature Range	-65°C to +150°C

1.5 Thermal Characteristics.

Thermal Resistance $\theta_{\text{JC}} = 35^\circ\text{C/W}$
 $\theta_{\text{JA}} = 120^\circ\text{C/W}$

AD7522 – SPECIFICATIONS

Test	Symbol	Device	Design Limit $T_{min}-T_{max}$	Sub Group 1	Sub Group 2, 3	Sub Group 4	Test Condition ¹	Units
Resolution	RES	-1, 2, 3	10				SC8 = "1"	Bits
Nonlinearity	NL	-1 -2 -3	2 1 1/2	2 2 2	2 1 1/2	1 1/2		± LSB max
Nonlinearity Tempco	TC _{NL}	-1, 2, 3	2					± ppm/°C max
Gain Tempco	TC _{GA}	-1, 2, 3	30					± ppm/°C max
Output Leakage Current Pin 6 Pin 7	I _{OUT1} I _{OUT2}	-1, 2, 3 -1, 2, 3	200 200	200 200	200 200		DB0 thru DB9 = 0 DB0 thru DB9 = 1	± nA max ± nA max
Feedthrough Error	FT	-1, 2, 3	10				V _{REF} = 20V p-p, 10kHz @ +25°C	mV p-p max
Reference Input Resistance	R _{IN}	-1, 2, 3	5 20	5 20	5 20			kΩ min kΩ max
Digital Input High Voltage	V _{IH}	-1, 2, 3	2.4 13.5	2.4 13.5	2.4 13.5		V _{CC} = +5V V _{CC} = +15V	V min V min
Digital Input Low Voltage	V _{IL}	-1, 2, 3	0.8 1.5	0.8 1.5	0.8 1.5		V _{CC} = +5V V _{CC} = +15V	V max V max
LDAC Pulse Width	t _{LD}	-1, 2, 3	500				LDAC: 0 to +3V	ns min
HBS, LBS Pulse Width	t _{BS}	-1, 2, 3	500				HBS, LBS: 0 to +3V	ns min
Serial Clock Frequency	f _{CLK}	-1, 2, 3	1					MHz max
HBS, LBS Data Setup ²	t _{DS}	-1, 2, 3	250					ns min
Data Hold Time ³	t _{DH}	-1, 2, 3	500					ns min
Supply Current from V _{DD}	I _{DD}	-1, 2, 3	2	2	2		In Quiescent State at +25°C All Logic Input V _{IL} or V _{IH} .	mA max
Supply Current from V _{CC}	I _{CC}	-1, 2, 3	2	2	2		In Quiescent State at +25°C All Logic Input V _{IL} or V _{IH} .	mA max

NOTES

¹V_{DD} = +15V; V_{CC} = +5V, V_{REF} = +10V unless otherwise stated.

²Data setup time is the minimum amount of time required for DB0–DB9 to be stable prior to strobing HBS, LBS.

³Data hold time is the minimum amount of time required for DB0–DB9 to be stable after strobing HBS, LBS.

Table 1.

3.2.1 Functional Block Diagram and Terminal Assignments.

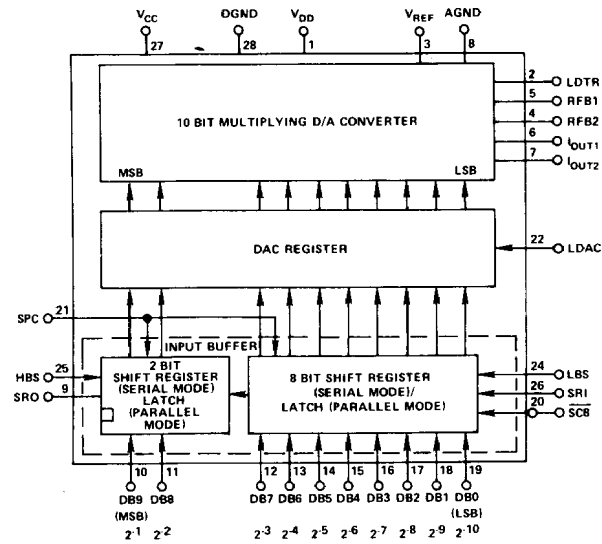

3.2.4 Microcircuit Technology Group.

This microcircuit is covered by technology group (80).

4.2.1 Life Test/Burn-In Circuit.

Steady state life test is per MIL-STD-883 Method 1005. Burn-in is per MIL-STD-883 Method 1015 test condition (B).

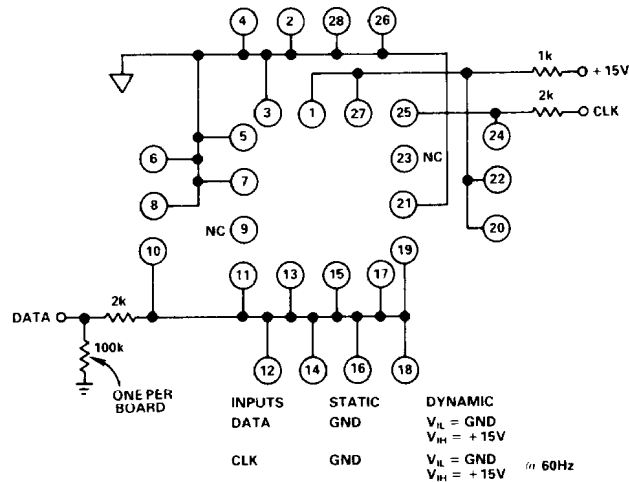

NOTE:
IF CLK INPUT IS USED, THEN DATA INPUT MAY BE TIED TO GROUND OR TO +15V. OR MAY BE EXERCISED DYNAMICALLY BY PRESENTING A LOGIC DIVISION BY TWO OF THE CLK INPUT.

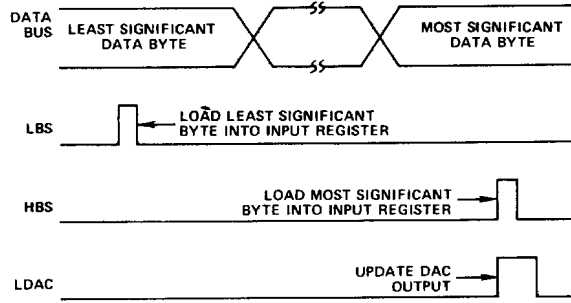

Figure 1. Timing Diagram

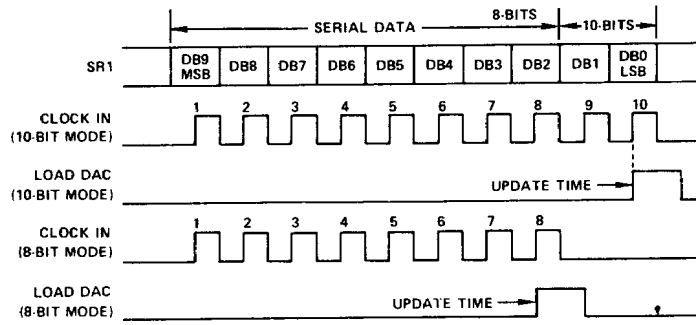

Figure 2. Timing Diagram for Serial 8- and 10-Bit Loading