

## BIPOLAR ANALOG INTEGRATED CIRCUIT $\mu$ PC1335V

T-74-05-01

### AUDIO POWER AMPLIFIER

#### DESCRIPTION

The  $\mu$ PC1335V is a class B dual audio power amplifier designed for a music center and a radio cassette, and is encapsulated in a new 14 Pins vertical dual in line plastic package.

#### FEATURES

- High output power.
  - 20 W (TYP.) @  $V_{CC} = 18$  V,  $R_L = 8 \Omega$  (BTL)
  - 5.5 W/ch (TYP.) @  $V_{CC} = 18$  V,  $R_L = 8 \Omega$
  - 7 W/ch (TYP.) @  $V_{CC} = 15$  V,  $R_L = 4 \Omega$
  - 5.7 W/ch (TYP.) @  $V_{CC} = 12$  V,  $R_L = 3 \Omega$
  - 4.6 W/ch (TYP.) @  $V_{CC} = 12$  V,  $R_L = 4 \Omega$
- Wide operating voltage range.  $V_{CC} = 6$  to 20 V
- Low quiescent current.  $I_{CC} = 23$  mA (TYP.) @  $V_{CC} = 15$  V
- Low noise.  $N_L = 0.25$  mV<sub>r.m.s.</sub> (TYP.)
- High supply voltage rejection. SVR = 55 dB (TYP.)
- No shock noise at power supply switch on and off.
- Soft clipping wave form.
- Thermal shut down circuit is built in.
- Low thermal resistance :  $R_{th(j-c)} = 3^\circ\text{C/W}$
- Very low number of external components, very simple mounting system with no electrical isolation between the package and the heat sink. (one screw only)

#### BLOCK DIAGRAM

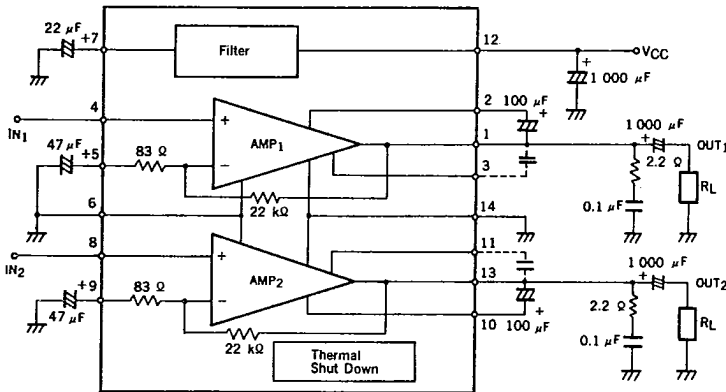

T-74-05-01

**CONNECTION DIAGRAM**

PIN NO.	CONNECTION
1	Output <sub>1</sub>
2	Boot Strap <sub>1</sub>
3	Compensation <sub>1</sub>
4	Input <sub>1</sub>
5	NFB <sub>1</sub>
6	GND (Input)
7	Filter
8	Input <sub>2</sub>
9	NFB <sub>2</sub>
10	Boot Strap <sub>2</sub>
11	Compensation <sub>2</sub>
12	V <sub>CC</sub>
13	Output <sub>2</sub>
14	GND (Output)

**ABSOLUTE MAXIMUM RATINGS (T<sub>a</sub> = 25 °C)**

Supply Voltage (No Signal)	V <sub>CC1</sub>	28	V
Supply Voltage (Operating)	V <sub>CC2</sub>	25	V
Power Dissipation	P <sub>D</sub>	14*	W
Operating Temperature	T <sub>opt</sub>	-20 to +70	°C
Storage Temperature	T <sub>stg</sub>	-40 to +150	°C

\* 100 x 100 x 2 mm Al heat sink

5

**RECOMMENDED OPERATING CONDITIONS (T<sub>a</sub> = 25 °C)**

ITEM	SYMBOL	MIN.	TYP.	MAX.	UNIT
Supply Voltage	V <sub>CC</sub>	6	12, 15	20	V
Load Impedance (DUAL)	R <sub>L</sub>	3	4	8	Ω
Load Impedance (BTL)	R <sub>L</sub>	4		8	Ω
Voltage Gain	A <sub>v</sub>	36	48		dB

7-79-05-01

**ELECTRICAL CHARACTERISTICS** ( $V_{CC} = 15\text{ V}$ ,  $R_L = 4\ \Omega$ ,  $f = 1\text{ kHz}$ ,  $T_a = 25\ ^\circ\text{C}$ ,  $100 \times 100 \times 2\text{ mm Al Panel Heat Sink}$ )

CHARACTERISTIC	SYMBOL	MIN.	TYP.	MAX.	UNIT	TEST CONDITION
Circuit Current	$I_{CC}$		23	36	mA	No Signal
Voltage Gain	$A_v$	46	48	50	dB	
Output Power	$P_O$		4.6		W	THD = 10 % $V_{CC} = 12\text{ V}$ , $R_L = 4\ \Omega$
			5.7		W	THD = 10 % $V_{CC} = 12\text{ V}$ , $R_L = 3\ \Omega$
		6	7		W	THD = 10 % $V_{CC} = 15\text{ V}$ , $R_L = 4\ \Omega$
			5.5		W	THD = 10 % $V_{CC} = 18\text{ V}$ , $R_L = 8\ \Omega$
			20		W	THD = 10 %, BTL $V_{CC} = 18\text{ V}$ , $R_L = 8\ \Omega$
Total Harmonic Distortion	THD		0.2	1	%	$P_O = 1\text{ W}$
Output Noise Voltage	NL		0.25	0.6	mV <sub>r.m.s.</sub>	DIN AUDIO $R_G = 0$
Cross Talk	C.T.	45	55		dB	$P_O = 2\text{ W}$ other Ch. $R_G = 0$
Channel Balance	Ch. B.	-1	0	+1	dB	$P_O = 4\text{ W}$
Ripple Rejection	SVR	45	55		dB	$R_G = 0$ , $f = 100\text{ Hz}$ $V = 0.3\text{ V}_{r.m.s.}$
Input impedance	$Z_{in}$	20	30		k $\Omega$	

**SWITCH POSITION**

ITEM	SYMBOL	SW <sub>1</sub>	SW <sub>2</sub>	SW <sub>3</sub>
(DUAL OPERATION)				
Circuit Current	$I_{CC}$	2	2	2
Voltage Gain	$A_v$	1	1	1
Output Power	$P_O$	1	1	1
Total Harmonic Distortion	THD	1	1	1
Output Noise Voltage	NL	2	2	1
Cross Talk	C.T.	1/2	2/1	1
Channel Balance	Ch.B.	1	1	1
Supply Voltage Rejection	SVR	2	2	1
(BTL OPERATION)				
Output Power	$P_O$	-	-	-

**TEST CIRCUIT  
(DUAL OPERATION)**

T-74-05-01

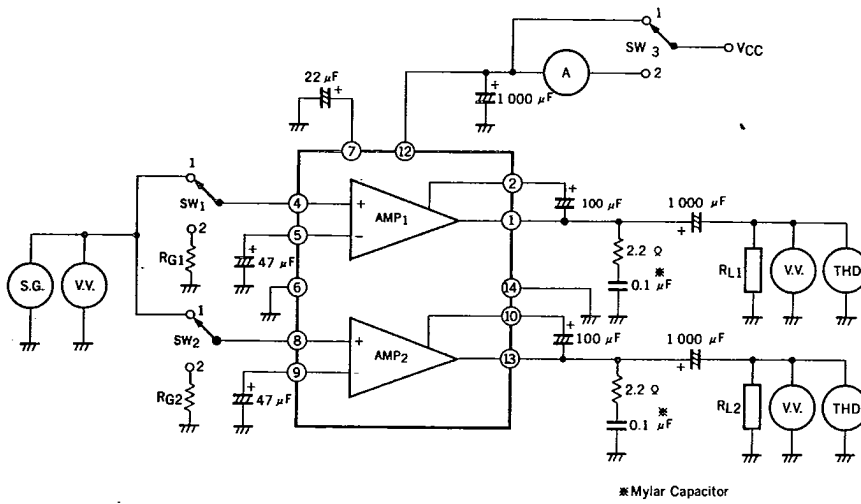

**(BTL OPERATION)**

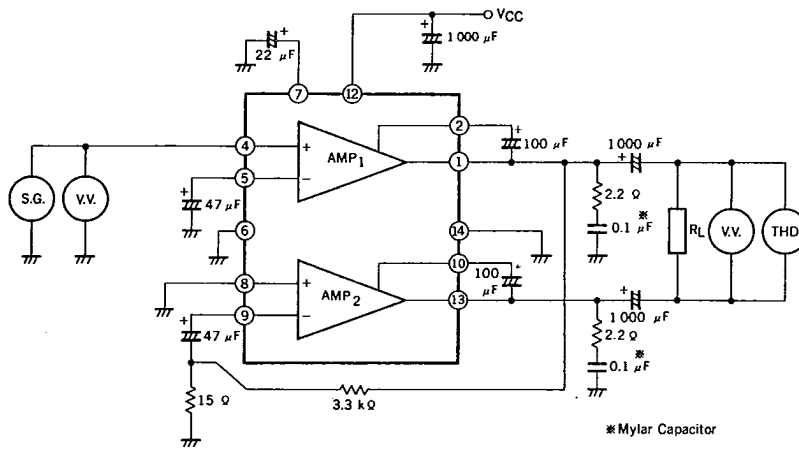

5

**TYPICAL APPLICATION**  
(DUAL OPERATION)

T-74-05-01

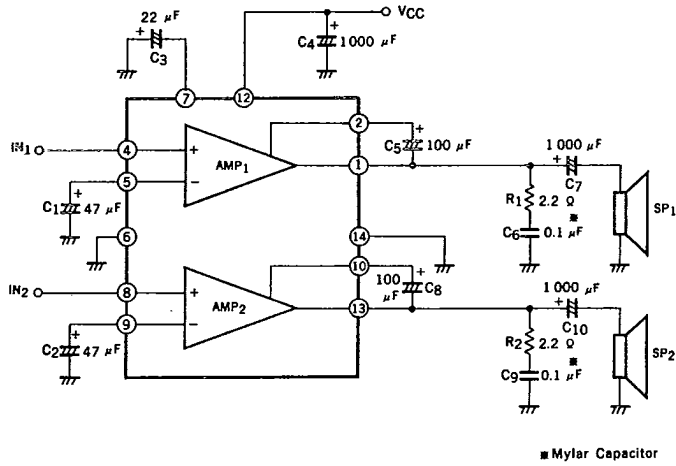

(BTL OPERATION)

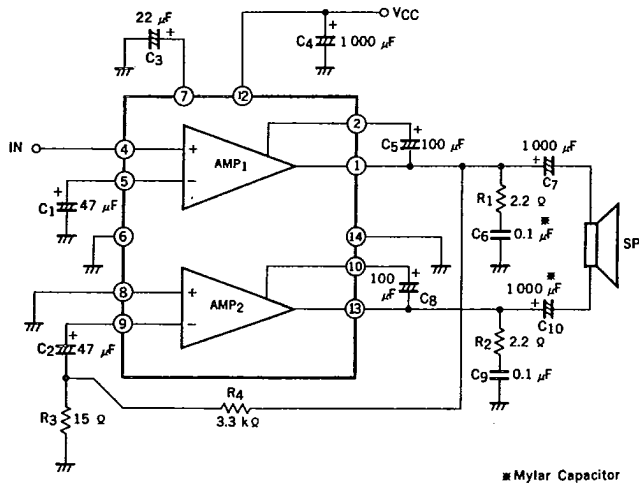

(MUTING CIRCUIT)

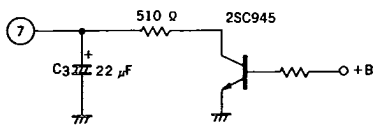

TYPICAL CHARACTERISTICS ( $T_a = 25^\circ\text{C}$ )

T-74-05-01

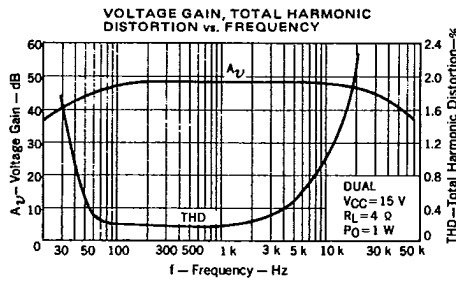
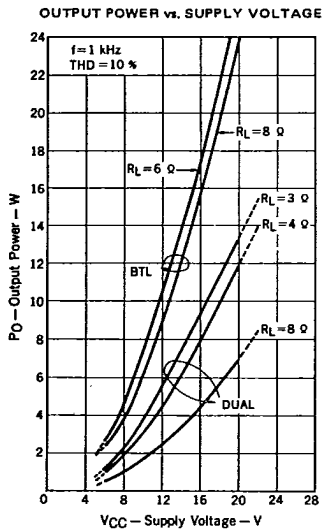
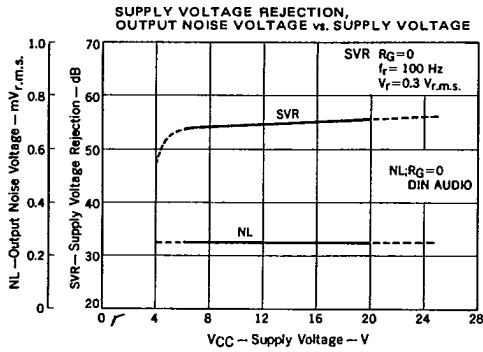
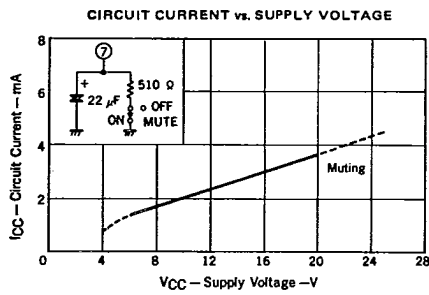
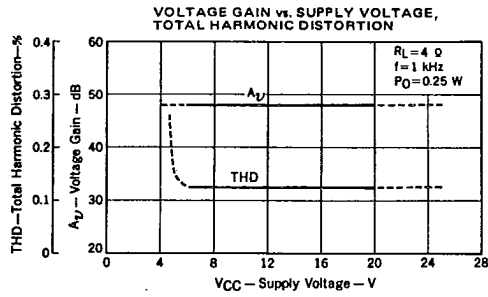
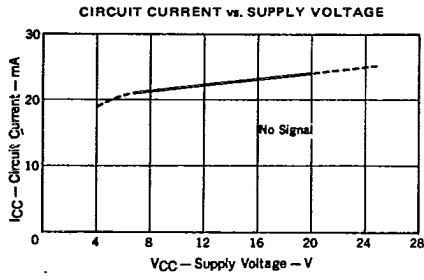

5

T-74-05-01

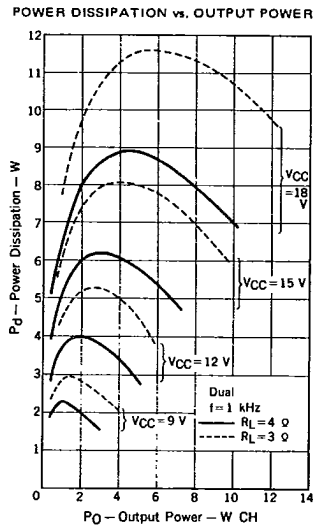
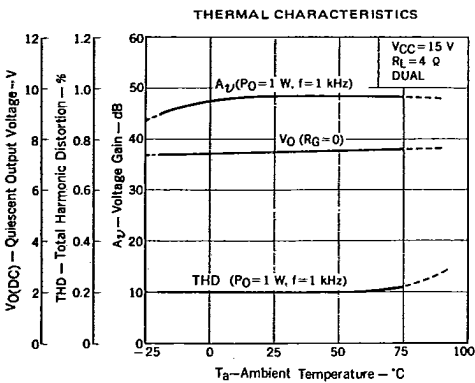
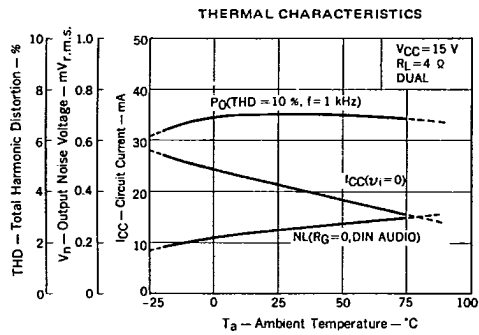
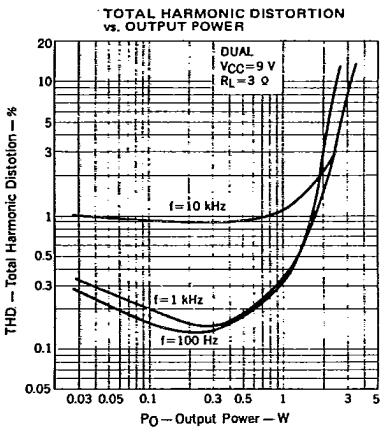
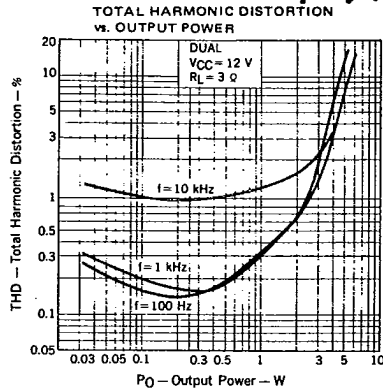
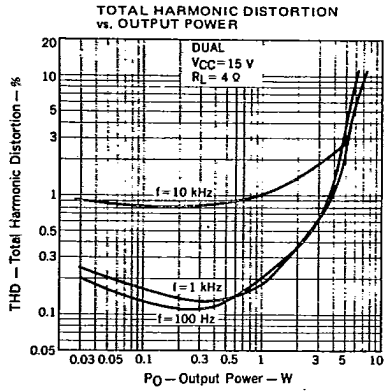

T-74-05-01

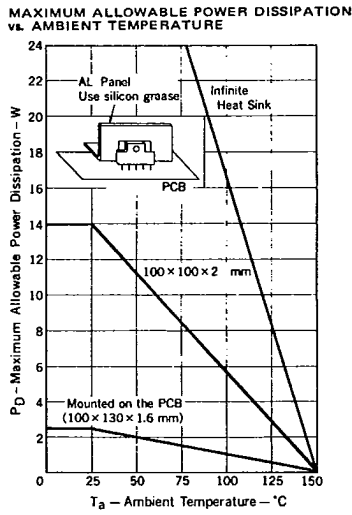
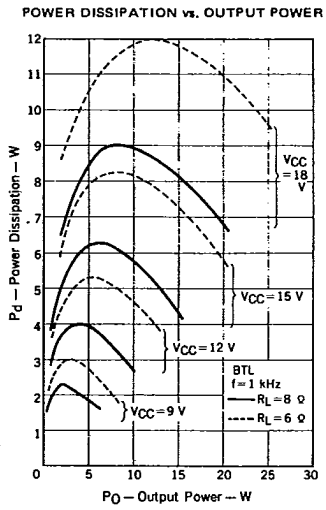
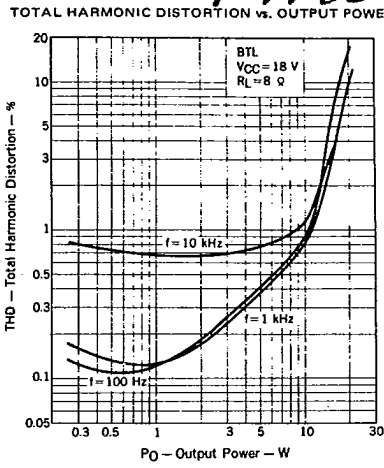
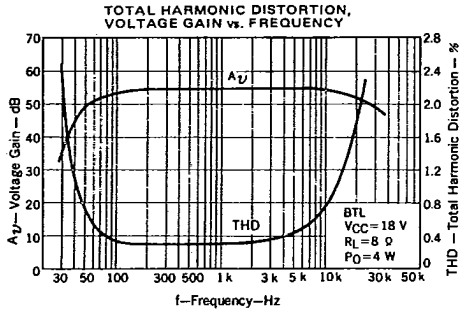



T-74-05-01

## NOTES FOR USE

- (1) Adding a capacitor for phase compensation between Pin 1 (13) to Pin 3 (11), its value less than 47 pF is recommended, and the value of  $R_1$  ( $R_2$ ) and of  $C_6$  ( $C_9$ ) have to be chosen as follows.

$$R_1 (R_2) = 1 \Omega$$

$$C_6 (C_9) = 0.15 \mu F$$

- (2) At muting by shortage of Pin 7 to GND, ripple rejection is determined by following equation.

$$SVR = \left| 20 \log \frac{R_L}{200+R_L} \right|$$

- (3) Keep the  $\mu PC1335V$ 's heat sink in shortage to GND or floating condition.  
(4) Direct shortage between Pin 1 (13) to  $V_{CC}$  or GND will damage the  $\mu PC1335V$ .  
(5) Keep some margin at design of external heat sink size.  
(6) Use silicon grease and keep the torque of screw driver less than 10 kg·cm in attachment of a external heat sink.

14 PIN V-DIP (Unit: mm)

T-74-05-01

