

TA84002F

PWM CHOPPER TYPE 2-PHASE BIPOLAR STEPPING MOTOR DRIVER

The TA84002F is designed to drive both windings of a two-phase bipolar stepping motor.

FEATURES

- Internal PWM current control
- Wide range of operating supply voltage
 V_M (motor) : 10 V to 30 V
 V_{CC} (control) : 4.5 V to 5.5 V
- Output current : 1.0 A (peak)
- Multichip IC consisting of four P-channel MOSFETs and one main chip.
- Full-step and half-step are available
- Internal thermal-shutdown circuit
- Package : HSOP20-P-450-1.00

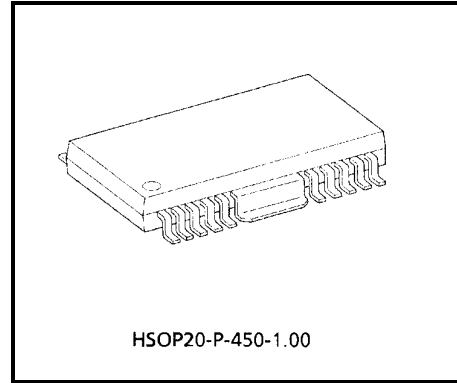

Weight : 0.79 g (Typ.)

Note1: This product has a multichip (MCP) structure utilizing Pch MOS technology. Take care when handling because Pch MOS has low electrostatic resistance.

PIN ASSIGNMENT

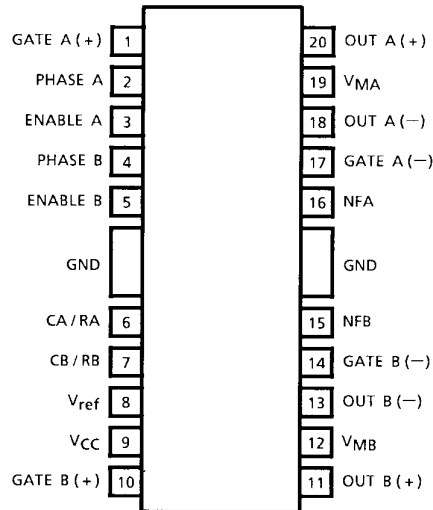

BLOCK DIAGRAM

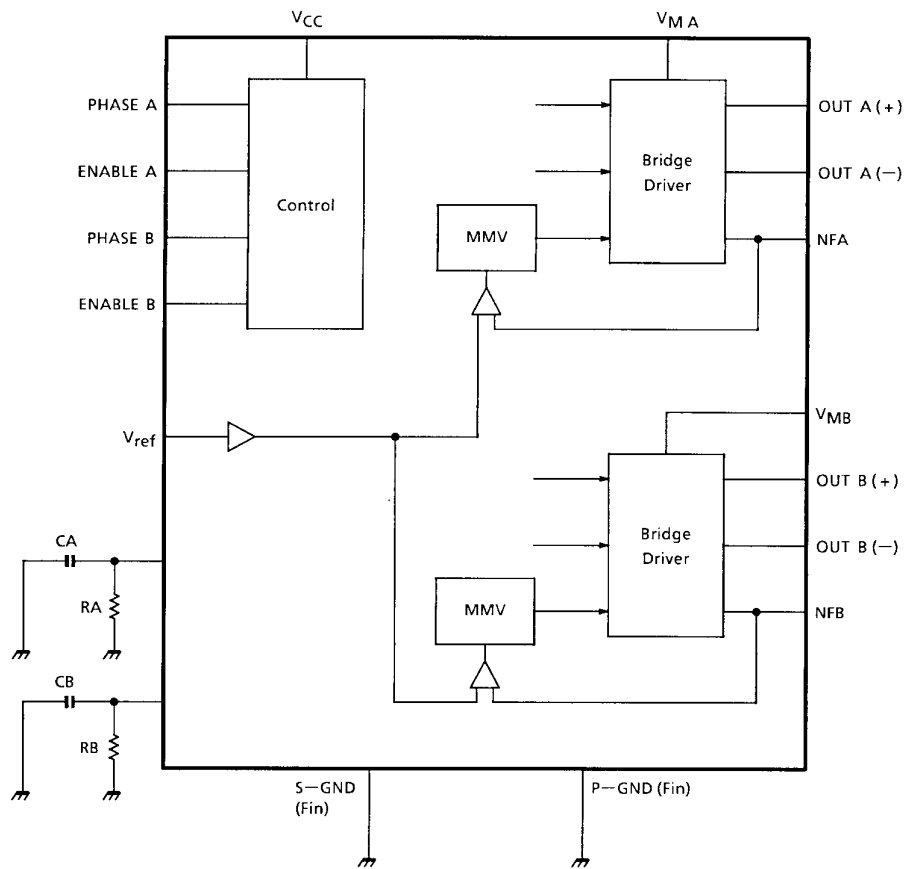

TRUTH TABLE

PHASE	ENABLE	OUT (+)	OUT (-)
X	H	OFF	OFF
H	L	H	L
L	L	L	H

X: Don't care

OUTPUT STAGE

- The TA84002F is Multichip IC consisting of four P-channel MOSFETs and one main chip.
- Four P-channel MOSFETs are used as upper-side power transistors.
- Output current is controlled by switching lower-side transistor.
- During CHOP ON, the current flows through P-channel MOS, The motor winding, sink transistor and sense resistor.
- During CHOP OFF, the current circulates the motor winding, P-channel MOS and the diode of P-channel MOS.
- Power dissipation is divided by the five chips.

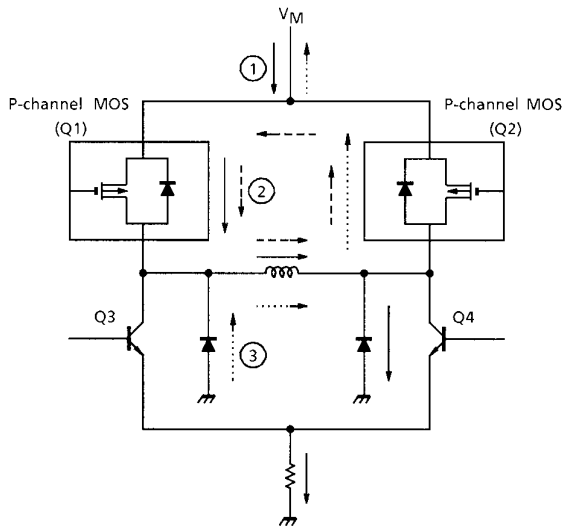

- : (1) CHOP ON
(Drive Mode)
Q1: ON, Q2: OFF
Q3: OFF, Q4: ON
- - → : (2) CHOP OFF
(Slow Decay)
Q1: ON, Q2: OFF
Q3: OFF, Q4: OFF
-→ : (3) ALL OFF
(Fast Decay)

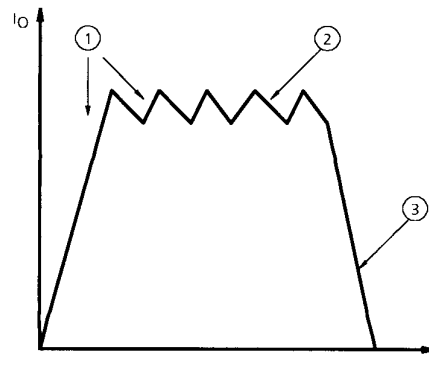

PWM CURRENT CONTROL

Output current is sensed and controlled independently in each bridge by an external sense resistor (RNF), internal comparator, and mono-stable multi-vibrator.

When the bridge is turn ON, current increases in the motor winding and flows through the external sense resistor until the sense voltage (VNF) reaches the level set at the comparator's input: $V_{ref} / 5$

The comparator then triggers the mono-stable, which turn OFF the lower transistor of the bridge.

The OFF time is determined by the mono-stable's external RC timing components.

$$t_{OFF} \approx 1.1 CR$$

The value of the current limiting (I_O) is approximated by

$$I_O = (V_{ref} / 5) / RNF - 0.05$$

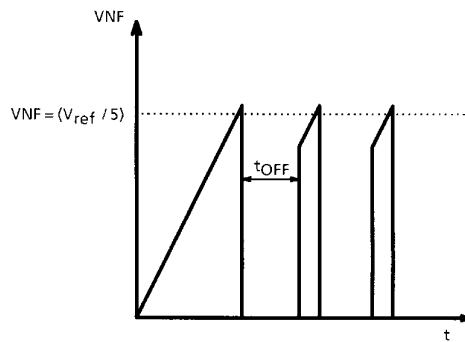
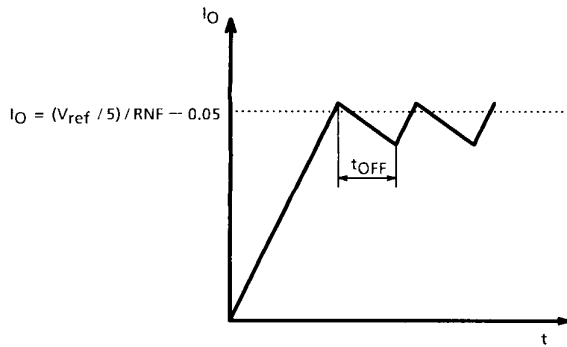
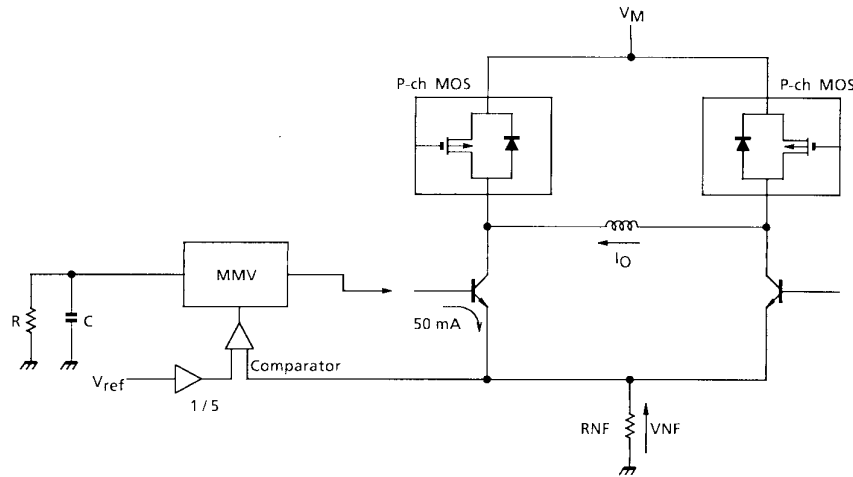

TIMING CHART

(1) Full Step

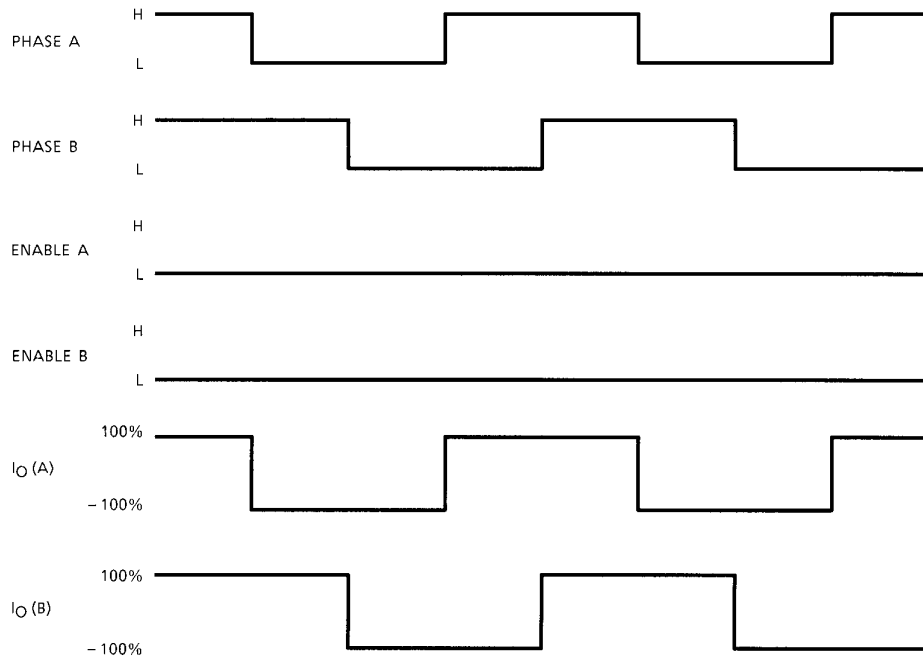

(2) Half Step

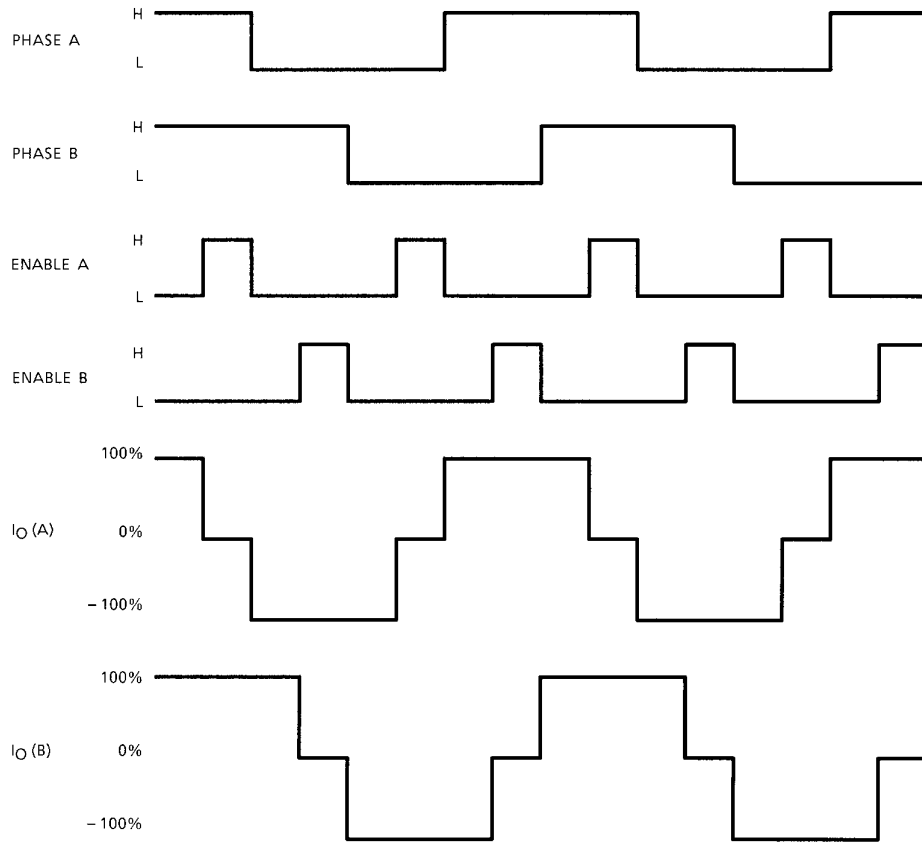

MAXIMUM RATINGS (Ta = 25°C)

CHARACTERISTIC	SYMBOL	RATING	UNIT
Supply Voltage (Motor)	V _M	35	V
Supply Voltage (Control)	V _{CC}	7	V
Output Current	I _O	1.0	A / ch
Input Voltage	V _{IN}	GND - 0.4 to V _{CC} + 0.4 V	V
Power Dissipation	P _D	2.5 (Note)	W
Operating Temperature	T _{opr}	-30 to 85	°C
Storage Temperature	T _{stg}	-55 to 150	°C

Note: This rating is obtained by mounting on 50 × 50 × 1.6 mm PCB that occupied above 60% of copper.

RECOMMENDED OPERATION CONDITION (Ta = -30 to 85°C)

CHARACTERISTIC	SYMBOL	TEST CIR-CUIT	TEST CONDITION	MIN	TYP.	MAX	UNIT
Supply Voltage (Control)	V _{CC}	—		4.5	5.0	5.5	V
Supply Voltage (Motor)	V _M	—		10	24	30	V
Output Current	I _O	—		—	—	0.8	A / ch
Input Voltage	V _{IN}	—	PHASE, ENABLE	GND	—	V _{CC}	V
Reference Voltage	V _{ref}	—		1.2	2.5	V _{CC} - 0.5	V
PWM Frequency	f _{PWM}	—		15	30	50	kHz

ELECTRICAL CHARACTERISTICS (Ta = 25°C, VCC = 5 V, VM = 24 V)

CHARACTERISTIC	SYMBOL	TEST CIR-CUIT	TEST CONDITION	MIN	TYP.	MAX	UNIT
Input Voltage	V _{IN(H)}	1	PHASE, ENABLE	2.0	—	V _{CC} + 0.3 V	V
	V _{IN(L)}			GND - 0.3 V	—	0.8	
Input Current	I _{IN(H)}	2	PHASE, ENABLE, V _{IN} = 5 V	—	2	20	μA
	I _{IN(L)}		PHASE, V _{IN} = GND	—	0	1	
	I _{IN(L)}		ENABLE, V _{IN} = GND	—	55	100	
Supply Current	I _{CC1}	3	ENABLE A / B = Low 2-Phase 100% ON	—	110	180	mA
	I _{CC2}	4	ENABLE A / B = Low 2-Phase 100% OFF	—	6	14	
	I _{CC3}	3	ENABLE A = Low, B = High 1-Phase 100% ON	—	55	90	
	I _{CC4}	4	ENABLE A = Low, B = High 1-Phase 100% OFF	—	6	14	
	I _{CC5}	3	ENABLE A / B = High 2-Phase OFF	—	6	14	
	I _{M1}	5	ENABLE A / B = Low 2-Phase ON	—	5	13	
	I _{M2}		ENABLE A = Low, B = High 1-Phase ON	—	4.5	11	
I _{M3}	ENABLE A / B = High 2-Phase OFF		—	4	9		
Output Saturation Voltage (Lower-side)	V _{SAT1}	6	I _O = 0.5 A	—	0.35	0.8	V
	V _{SAT2}		I _O = 1.0 A	—	0.65	2.0	
ON Resistor (Upper-side)	R _{on1}	7	I _O = 0.5 A	—	0.6	1.0	Ω
Diode Forward Voltage (Lower-side)	V _{F(L)}	8	I _F = 1.0 A	—	1.4	2.0	V
Diode Forward Voltage (Upper-side)	V _{F(H)}	9	I _F = 1.0 A	—	0.95	1.8	V
Reference Voltage Range	V _{ref}	—		1.0	2.5	V _{CC} - 0.5	V
Reference Current	I _{ref}	10	V _{ref} = 2.5 V	—	0.2	5	μA
Reference Divider Ratio	GAIN	11	V _{NF} / V _{ref}	0.17	0.2	0.23	
Setting Current	I _{set}	—	V _{ref} = 2.5 V, R _{NF} = 1 Ω	0.35	0.45	0.55	A
Thermal Shutdown Temperature	TSD	—	T _j	—	165	—	°C
Thermal Shutdown Hysteresis	ΔT	—		—	15	—	°C
Output Leakage Current	I _{L (H)}	12	P-channel MOS	—	0	100	μA
	I _{L (L)}			—	0	50	
Pch MOS Drive Current	I _G	13		330	530	730	μA

TEST CIRCUIT

1. V_{IN} (H), V_{IN} (L)

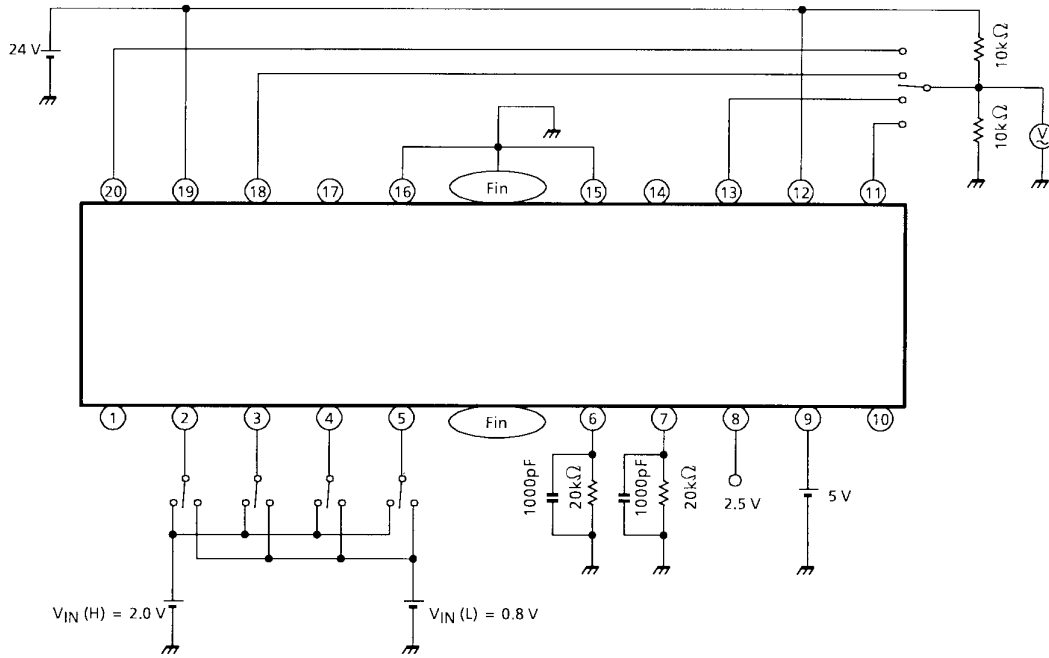

2. I_{IN} (H), I_{IN} (L)

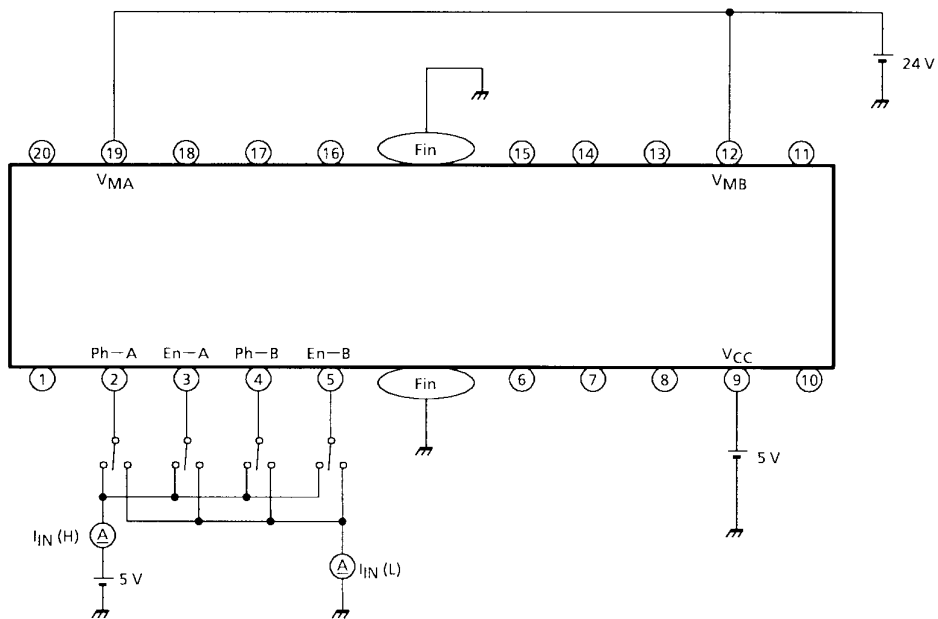

3. Icc1, Icc3, Icc5

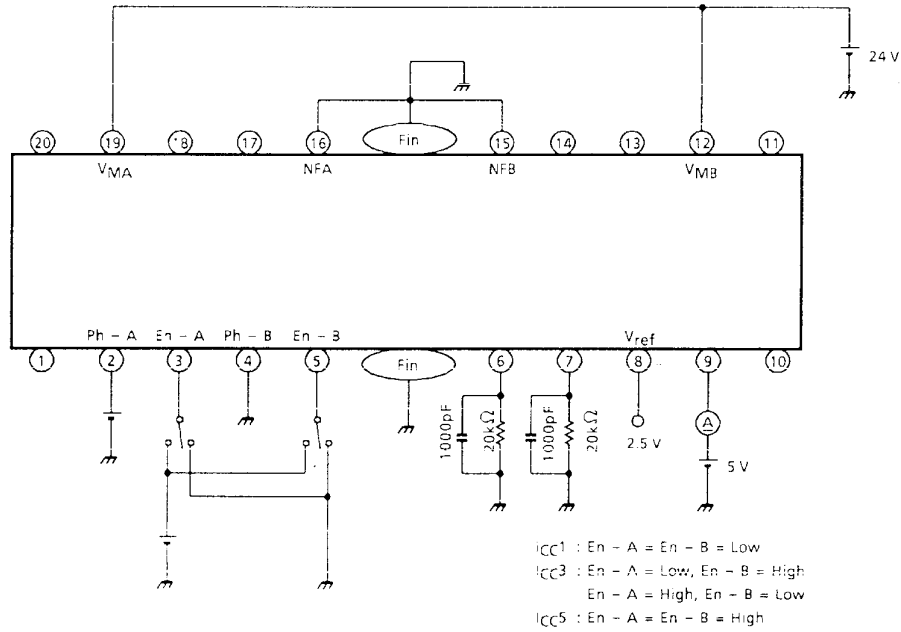

4. Icc2, Icc4

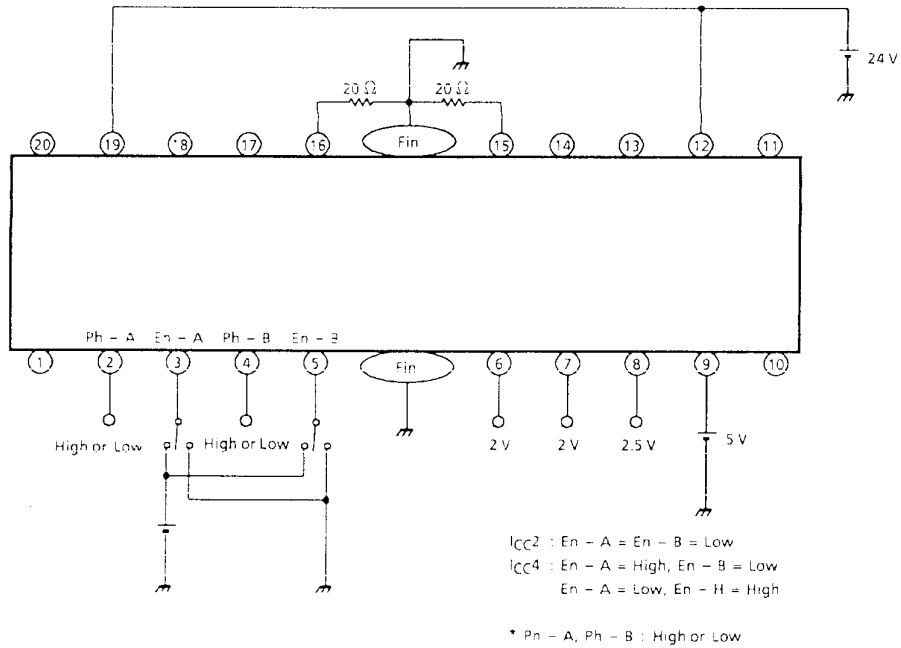

5. I_{M1}, I_{M2}, I_{M3}

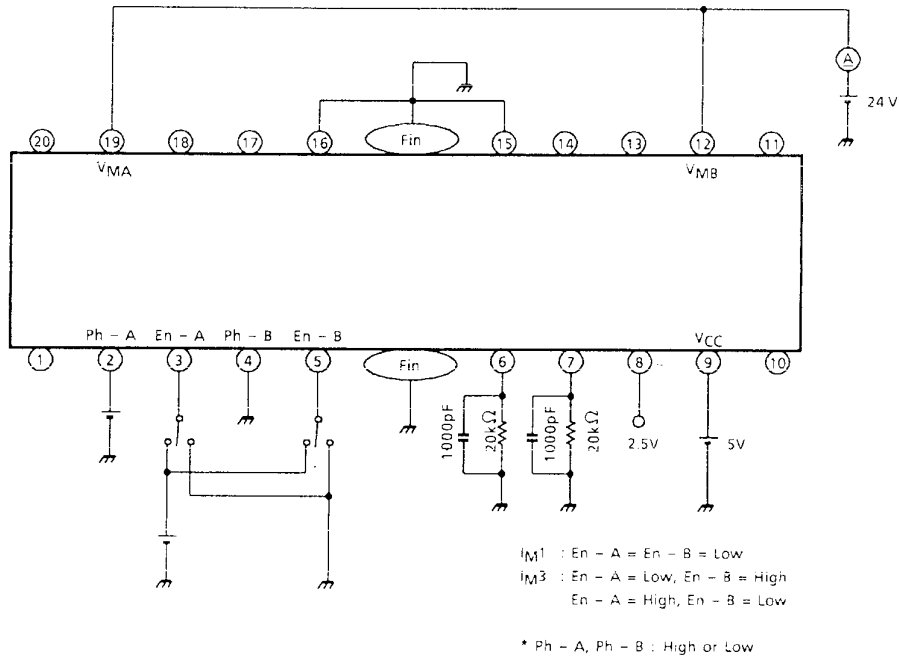

6. V_{SAT1}, V_{SAT2}

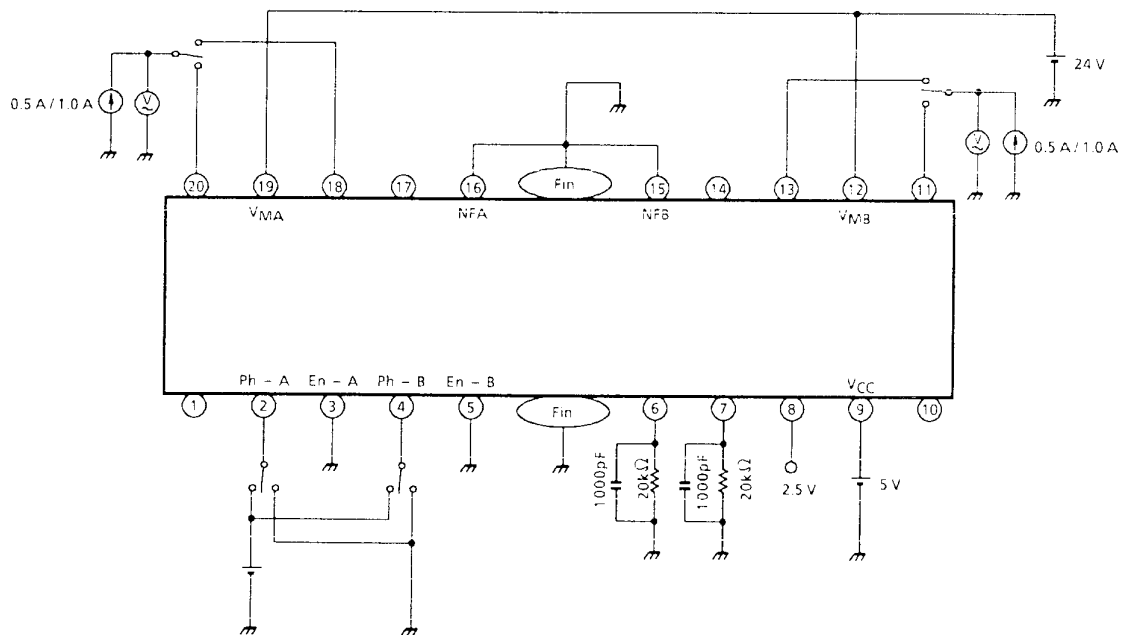

7. Ron1

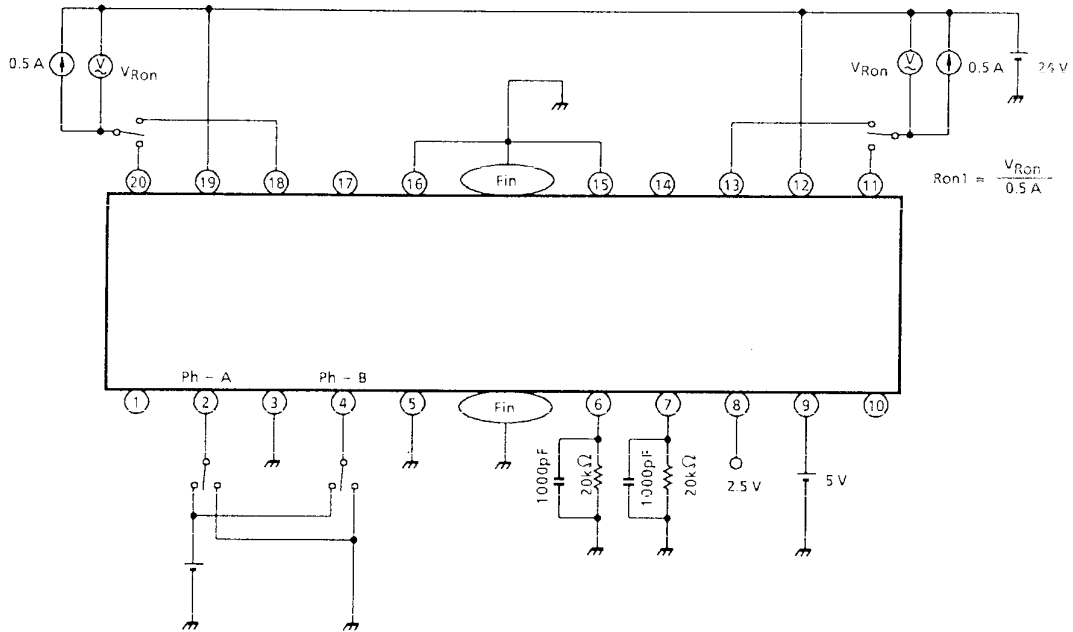

8. VF (L)

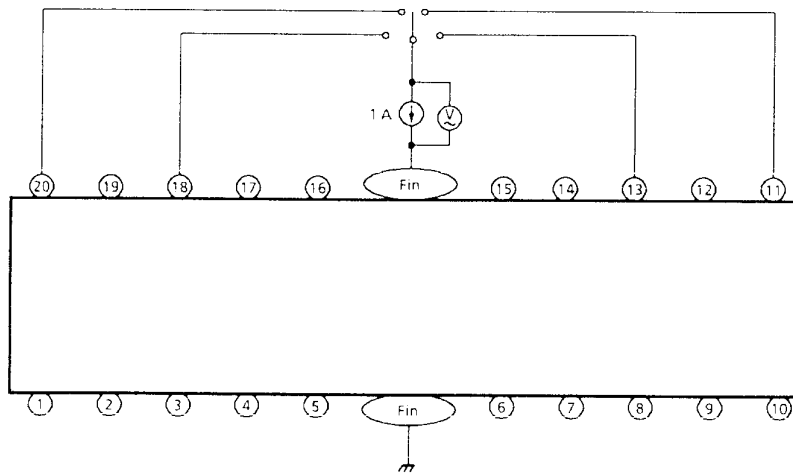

9. VF (H)

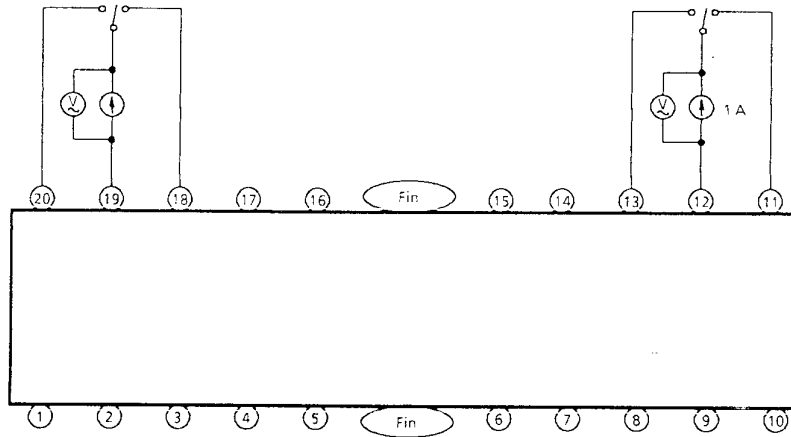

10. I_{ref}

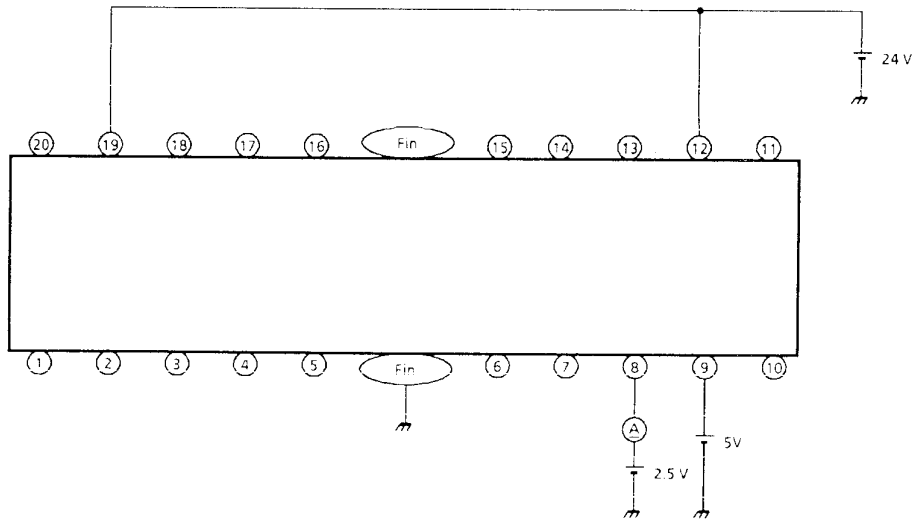

11. I_{set}

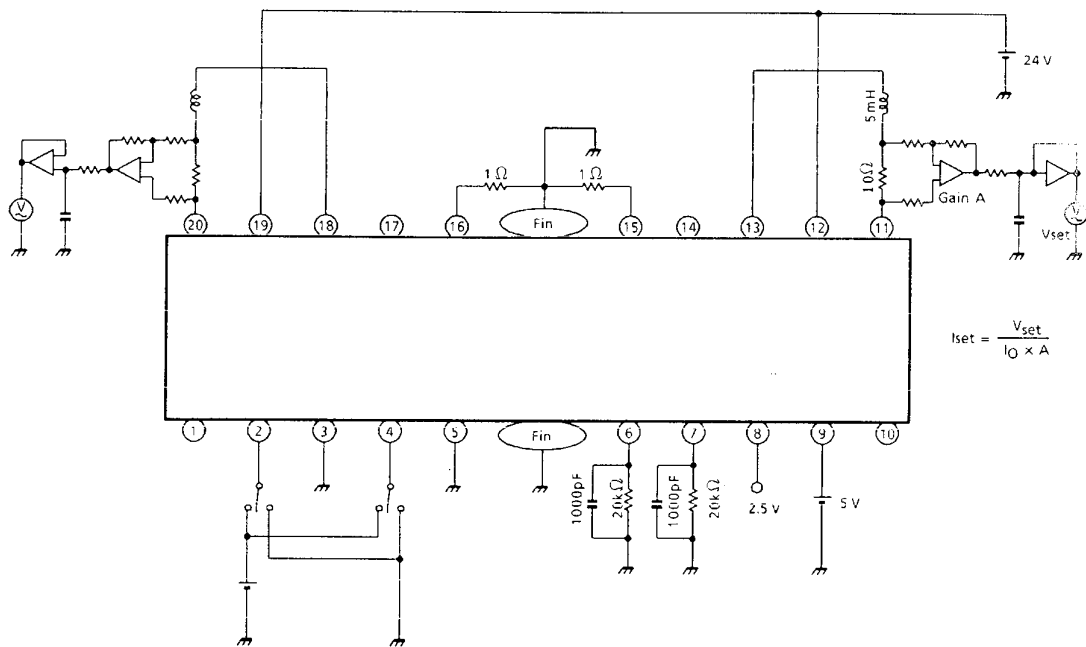

12. I_L (H), I_L (L)

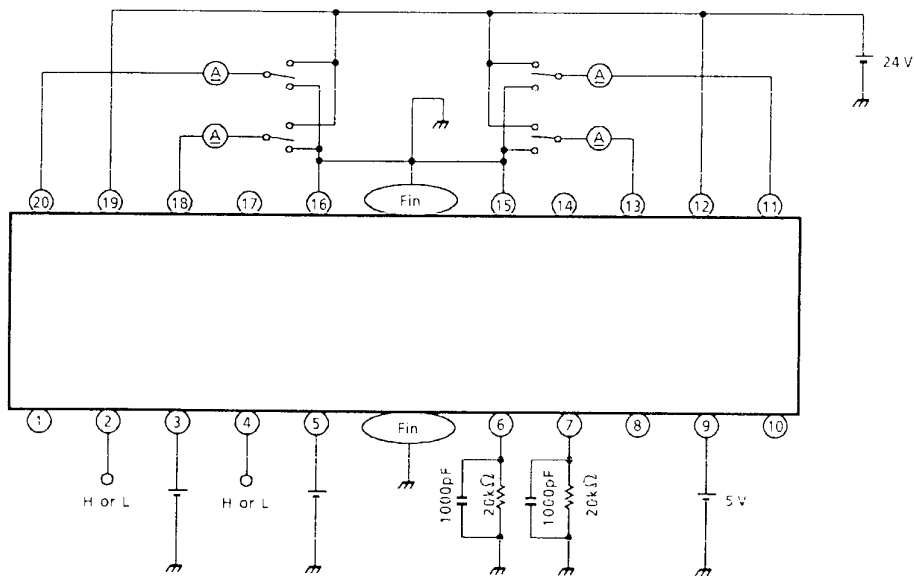

13. I_G

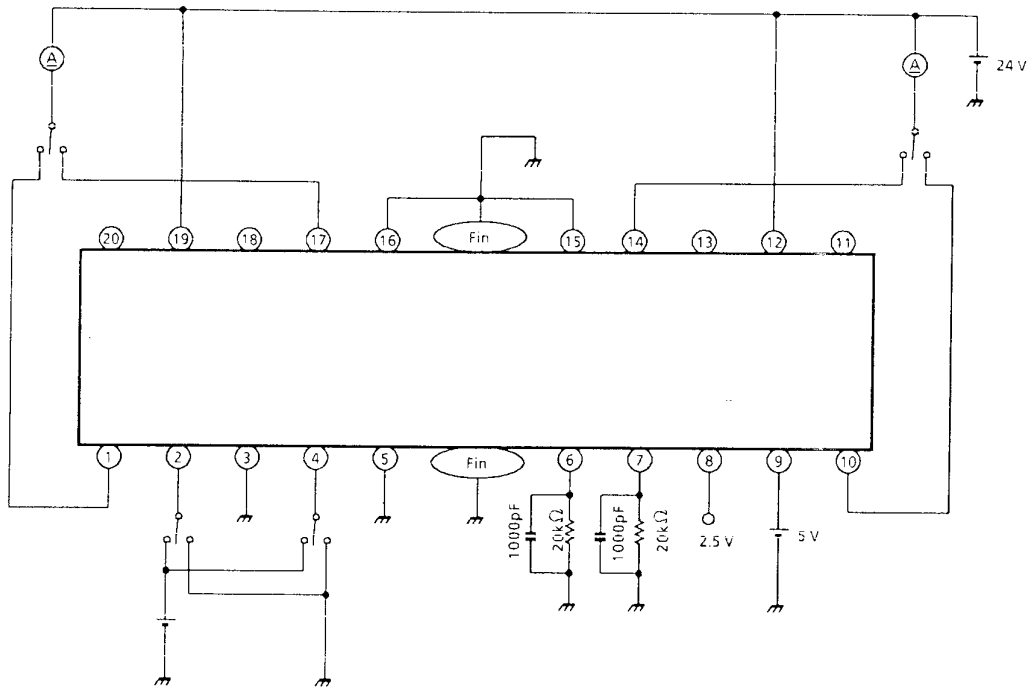

APPLICATION CIRCUIT

In case of $I_{OUT} = 0.5\text{ A}$

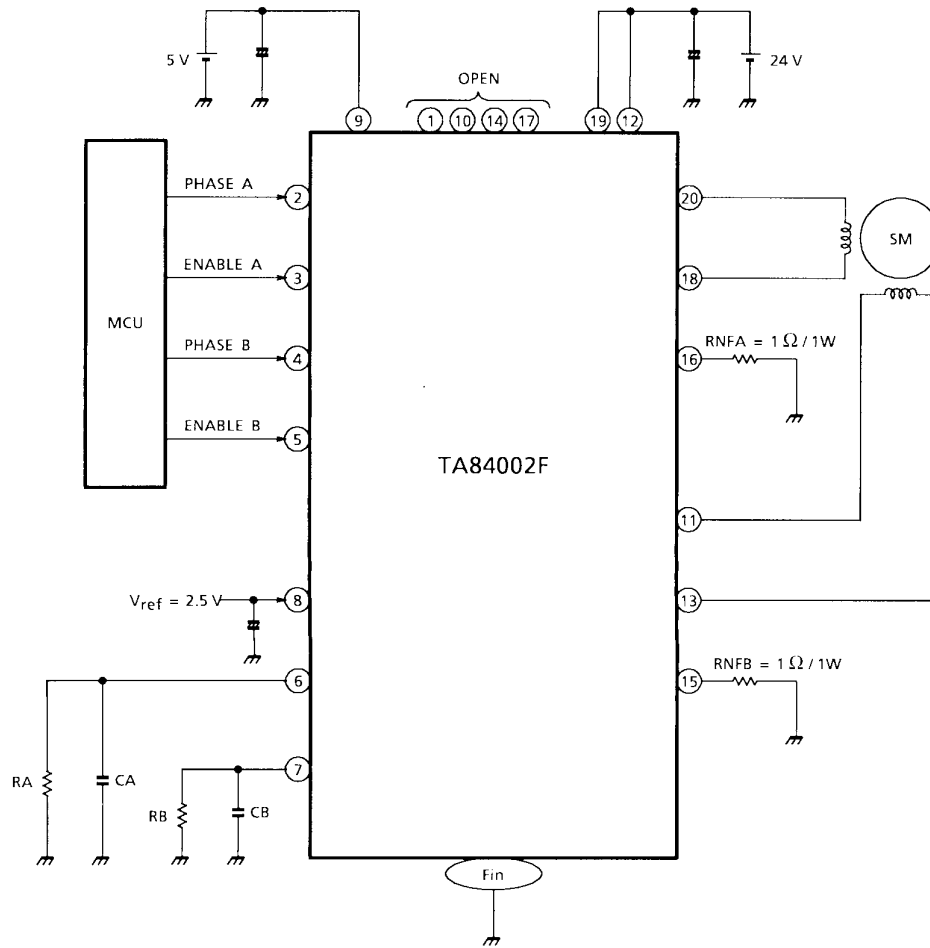

Note 1: Capacitor for noise suppression to be connected between the Power Supply (V_{CC} , V_M , V_{ref}) and GND to stabilize the operation.

Note 2: Utmost care is necessary in the design of the output line, V_M and GND line since IC may be destroyed due to short-circuit between outputs, air contamination fault, or fault by improper grounding.

PACKAGE DIMENSIONS

HSOP20-P-450-1.00

Unit : mm

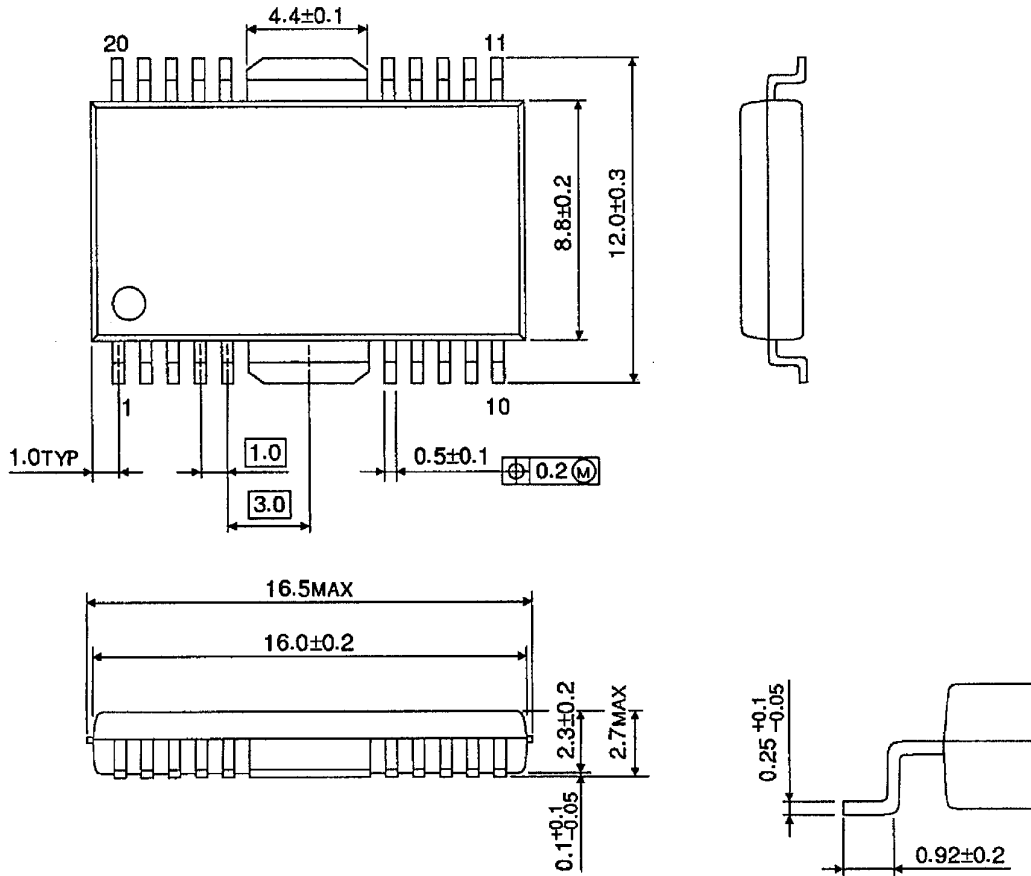

Weight : 0.79 g (Typ.)

RESTRICTIONS ON PRODUCT USE

000707EBA

- TOSHIBA is continually working to improve the quality and reliability of its products. Nevertheless, semiconductor devices in general can malfunction or fail due to their inherent electrical sensitivity and vulnerability to physical stress. It is the responsibility of the buyer, when utilizing TOSHIBA products, to comply with the standards of safety in making a safe design for the entire system, and to avoid situations in which a malfunction or failure of such TOSHIBA products could cause loss of human life, bodily injury or damage to property.
In developing your designs, please ensure that TOSHIBA products are used within specified operating ranges as set forth in the most recent TOSHIBA products specifications. Also, please keep in mind the precautions and conditions set forth in the "Handling Guide for Semiconductor Devices," or "TOSHIBA Semiconductor Reliability Handbook" etc..
- The TOSHIBA products listed in this document are intended for usage in general electronics applications (computer, personal equipment, office equipment, measuring equipment, industrial robotics, domestic appliances, etc.). These TOSHIBA products are neither intended nor warranted for usage in equipment that requires extraordinarily high quality and/or reliability or a malfunction or failure of which may cause loss of human life or bodily injury ("Unintended Usage"). Unintended Usage include atomic energy control instruments, airplane or spaceship instruments, transportation instruments, traffic signal instruments, combustion control instruments, medical instruments, all types of safety devices, etc.. Unintended Usage of TOSHIBA products listed in this document shall be made at the customer's own risk.
- The products described in this document are subject to the foreign exchange and foreign trade laws.
- The information contained herein is presented only as a guide for the applications of our products. No responsibility is assumed by TOSHIBA CORPORATION for any infringements of intellectual property or other rights of the third parties which may result from its use. No license is granted by implication or otherwise under any intellectual property or other rights of TOSHIBA CORPORATION or others.
- The information contained herein is subject to change without notice.