

TA8000F

5V VOLTAGE REGULATOR WITH WATCHDOG TIMER

The TA8000F is an IC specially designed for micro-computer systems. It produces an output voltage of $5 \pm 0.25V$ without need for adjustment from its accurate reference voltage and amplifier circuit. At power-on, it outputs a reset signal to reset the system. It will also output a reset signal when the 5V output voltage drops below 85% because of external disturbance or other problem. It also incorporates a watchdog timer for self-diagnosing the system. When the system malfunctions, the IC generates reset pulses intermittently to prevent the system from running away.

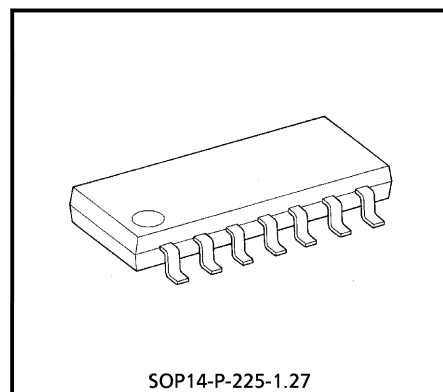

Weight : 0.2g (Typ.)

FEATURES

- Accurate output : $5 \pm 0.25V$
- Output voltage adjusting pin attached
- Power-on reset timer incorporated
- Watchdog timer incorporated
- Wide operating voltage range : 40V (max.)
- Operating temperature range : from -40 to $85^{\circ}C$
- Load dump protection : 80V (max.) (1 second)
- SOP-14 pin

BLOCK DIAGRAM AND PIN LAYOUT

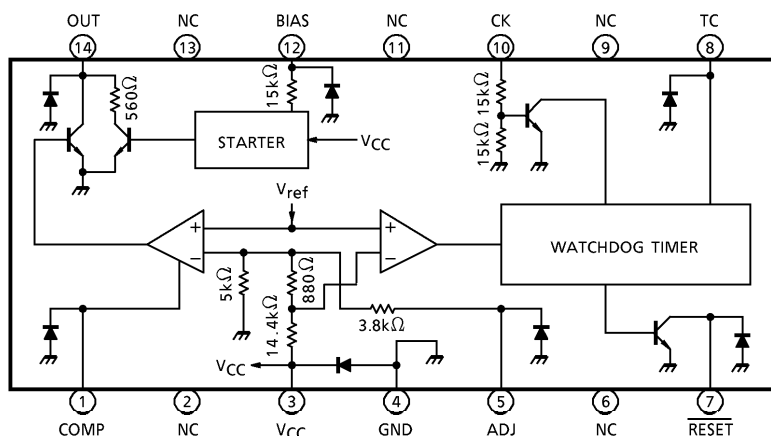

961001EBA2

● TOSHIBA is continually working to improve the quality and the reliability of its products. Nevertheless, semiconductor devices in general can malfunction or fail due to their inherent electrical sensitivity and vulnerability to physical stress. It is the responsibility of the buyer, when utilizing TOSHIBA products, to observe standards of safety, and to avoid situations in which a malfunction or failure of a TOSHIBA product could cause loss of human life, bodily injury or damage to property. In developing your designs, please ensure that TOSHIBA products are used within specified operating ranges as set forth in the most recent products specifications. Also, please keep in mind the precautions and conditions set forth in the TOSHIBA Semiconductor Reliability Handbook.

● The products described in this document are subject to foreign exchange and foreign trade control laws.

● The information contained herein is presented only as a guide for the applications of our products. No responsibility is assumed by TOSHIBA CORPORATION for any infringement of intellectual property or other rights of the third parties which may result from its use. No license is granted by implication or otherwise under any intellectual property or other rights of TOSHIBA CORPORATION or others.

● The information contained herein is subject to change without notice.

PIN DESCRIPTION

PIN No.	SYMBOL	DESCRIPTION
1	COMP	Phase compensation pin for output stabilization
3	V _{CC}	Power supply pin for internal circuit. The output voltage can also be detected at this pin.
4	GND	Grounded
5	ADJ	Output voltage adjusting pin. The voltage will increase when a resistor is inserted between ADJ and GND. It will reduce when a resistor is inserted between ADJ and V _{CC} . It will become 10V when ADJ and GND are directly connected.
7	$\overline{\text{RESET}}$	NPN transistor open-collector output. (1) The signal goes low when the output drops below 85% of the specified level. (2) The pin supplies a reset signal determined by the CR combination connected to the TC pin. (3) The pin supplies reset pulses intermittently if no clock is given to the CK pin. This function is useful when the IC is used as a watchdog timer for a microcomputer system.
8	TC	Time setting pin for the reset and watchdog timers
10	CK	Input pin for watchdog timer. The pin is pulled up to V _{CC} if the IC is used only as a power-on reset timer.
12	BIAS	Power supply starting pin. The starting current is supplied through a resistor to which the input voltage is applied. The output current from this starting current is as follows : $I_{\text{OUT}}(\text{pin } 12) \geq 30 \times (V_{\text{IN}} - 0.7) / (15 + R_1) \text{ (mA)}$ where R ₁ is the external resistance attached to pin 12 (k Ω). When V _{CC} rises above 2.7V, the starting current is absorbed in the internal circuit ; instead, I _{OUT} is supplied via V _{CC} .
14	OUT	Connected to the base of an external PNP transistor so that the output voltage is stabilized. Power supply design suitable for particular load capacities is thus possible. Since the recommended maximum I _{OUT} is 8mA, an output current of 300mA is assured if the external transistor has an H _{FE} of 40 or more.
2, 6, 9, 11, 13	N.C	Not connected

TIMING CHART

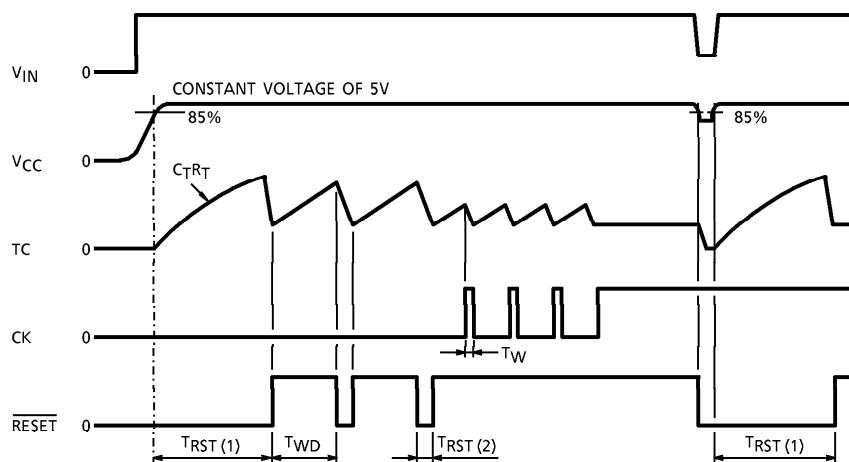

MAXIMUM RATINGS ($T_a = 25^\circ\text{C}$)

CHARACTERISTIC	SYMBOL	RATING	UNIT
Input Voltage	V_{IN1}	80 (1s)	V
	V_{IN2}	- 5~16	
Output Current	I_{OUT1}	10	mA
	I_{OUT2}	4	
Output Voltage	V_{OUT1}	80 (1s)	V
	V_{OUT2}	16	
Power Dissipation	P_D	280	mW
Operating Temperature	T_{opr}	- 40~85	$^\circ\text{C}$
Storage Temperature	T_{stg}	- 55~150	$^\circ\text{C}$
Lead Temperature-time	T_{sol}	260 (10s)	$^\circ\text{C}$

(Note) V_{IN1} : BIAS input
 V_{IN2} : CK input
 I_{OUT1} , V_{OUT1} : OUT output
 I_{OUT2} , V_{OUT2} : \overline{RESET} output

ELECTRICAL CHARACTERISTICS ($V_{IN} = 6$ to $17V$, $T_a = -40$ to $85^\circ C$)

CHARACTERISTIC	SYMBOL	PIN	TEST CIRCUIT	TEST CONDITION	MIN.	TYP.	MAX.	UNIT
Output Voltage	V_{REG}	V_{CC}	—	—	4.75	5.0	5.25	V
Line Regulation	—	V_{CC}	—	$V_{IN} = 6 \sim 40V$	—	0.1	0.5	%
Load Regulation	—	V_{CC}	—	$I_{LOAD} = 1 \sim 50mA$	—	0.1	0.5	%
Temperature Coefficient	—	V_{CC}	—	—	—	0.01	—	% / $^\circ C$
Output Voltage	V_{OL}	\overline{RESET}	—	$I_{OL} = 2mA$	—	—	0.5	V
Output Leakage Current	I_{LEAK}	\overline{RESET}	—	$V_{OUT} = 10V$	—	—	5	μA
Input Current	I_{IN}	TC	—	$V_{IN} = 0 \sim 3.5V$	-3	—	3	μA
Threshold Voltage	V_{IH}	TC	—	\overline{RESET} High to Low	—	$80\% \times V_{REG}$	—	V
	V_{IL}		—	\overline{RESET} Low to High	—	$40\% \times V_{REG}$	—	
Input Current	I_{IN}	CK	—	$V_{IN} = 5V$	—	0.3	0.7	mA
Input Voltage	V_{IH}	CK	—	—	2	—	—	V
	V_{IL}	CK	—	—	—	—	0.5	
Reset Detect Voltage	—	V_{CC}	—	—	$82\% \times V_{REG}$	$85\% \times V_{REG}$	$88\% \times V_{REG}$	V
Standby Current	I_S	V_{CC}	—	$V_{IN} = 14V$	—	5	6.5	mA
Watchdog Timer	T_{WD}	\overline{RESET}	—	—	$0.9 \times C_{TRT}$	$1.1 \times C_{TRT}$	$1.3 \times C_{TRT}$	—
Reset Timer (1)	$T_{RST(1)}$	\overline{RESET}	—	—	$1.3 \times C_{TRT}$	$1.6 \times C_{TRT}$	$1.9 \times C_{TRT}$	—
Reset Timer (2)	$T_{RST(2)}$	\overline{RESET}	—	—	$150 \times C_T$	$300 \times C_T$	$600 \times C_T$	—
Clock Pulse Width	T_W	CK	—	—	3	—	—	μs

Note : Reset timer (1) : Power-on reset time
Reset timer (2) : Watchdog reset time

TYPICAL CHARACTERISTICS

1. Input-output characteristic
($R_L = 25\Omega$, external transistor 2SA968-Y)

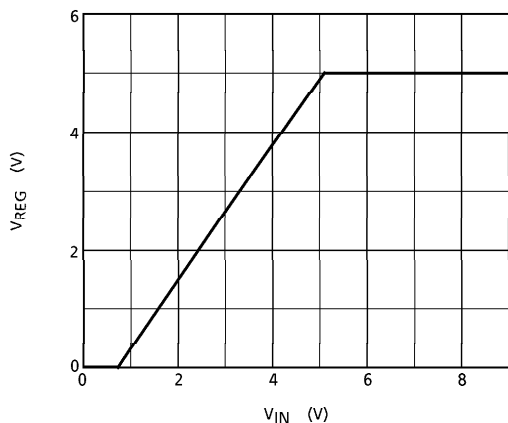

2. Reset Output Characteristic

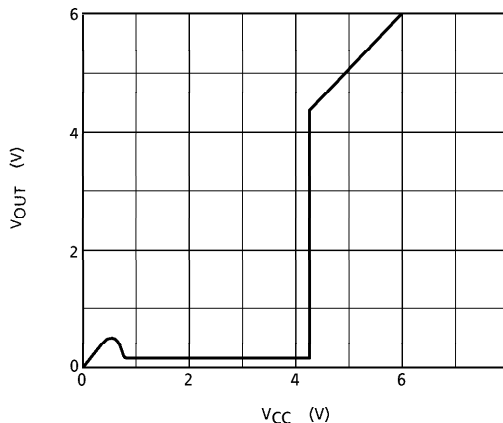

EXAMPLE OF APPLICATION CIRCUIT

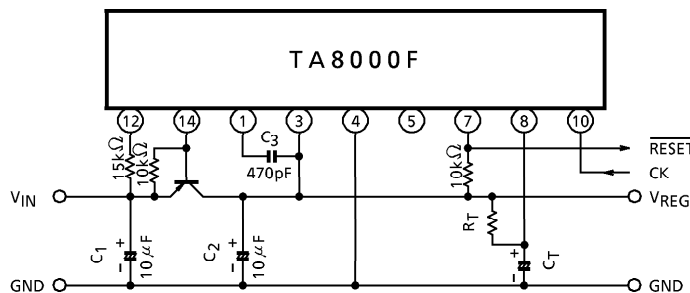

- * Cautions for Wiring
 1. C₁ and C₂ are for absorbing disturbance, noise, etc. Connect them as close to the IC as possible.
 2. C₃ is for phase compensation. Also, connect C₃ close to the IC.

APPLICATION CIRCUIT OF WATCHDOG / RESET TIMERS

1. T_{RST} (1) ≐ 10ms……Power-On Reset Timer

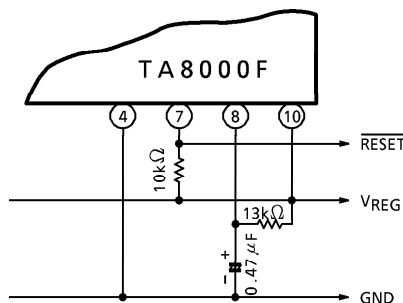

2. $T_{RST(1)} \doteq 1.5T_{WD}$

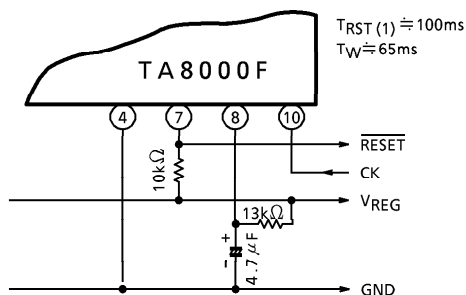

3. $T_{RST(1)} \doteq 100\text{ms}$, $T_{WD} \doteq 300\text{ms}$

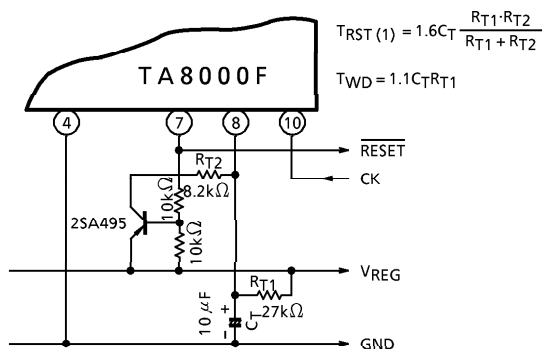

4. Recommended Conditions

PART NAME	MIN.	MAX.	UNIT
C_T	0.01	100	μF
R_T	5	100	$\text{k}\Omega$
R_{T1}	—	100	$\text{k}\Omega$
$R_{T1} // R_{T2}$ (Note)	5	—	$\text{k}\Omega$

(Note : $R_{T1} // R_{T2} = (R_{T1} \times R_{T2}) / (R_{T1} + R_{T2})$)

CK INPUT APPLICATION CIRCUIT

Capacitor Coupling

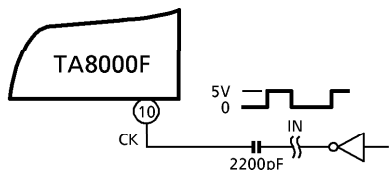

Timing Chart

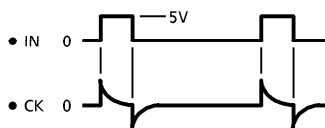

The capacitor coupling allows reset pulses to be supplied intermittently from the $\overline{\text{RESET}}$ pin whether the input level (IN) is high or low.

OUTLINE DRAWING
SOP14-P-225-1.27

Unit : mm

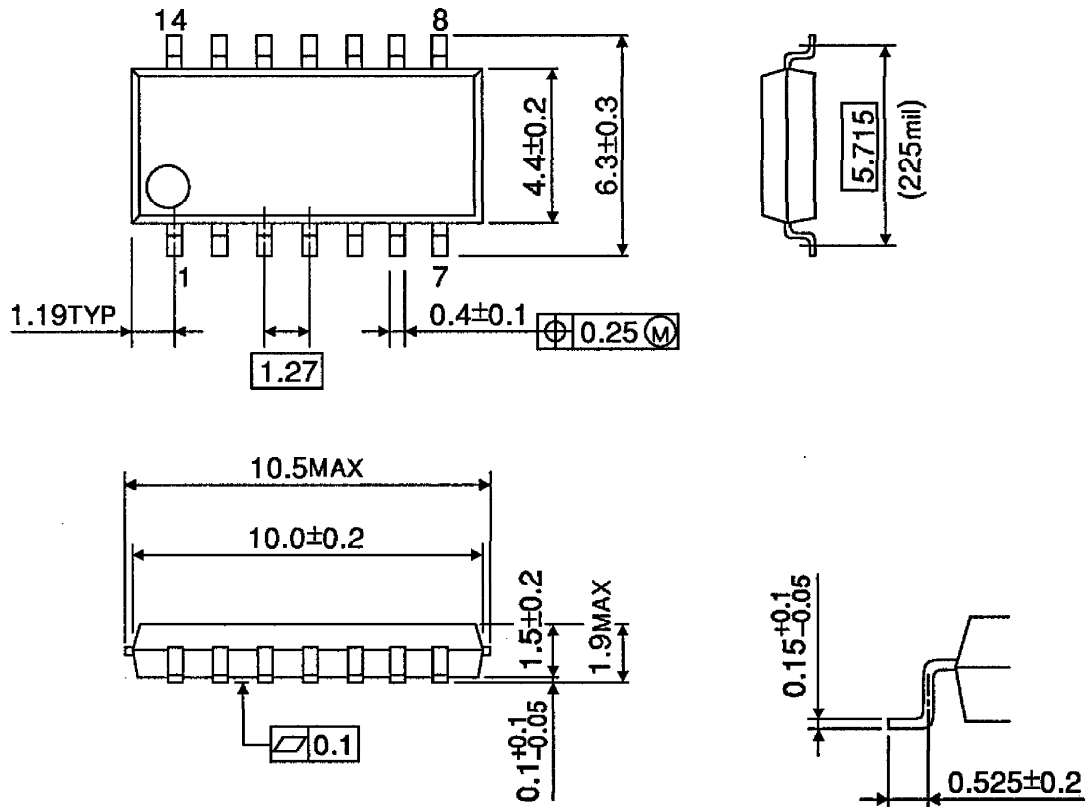

Weight : 0.2g (Typ.)