

THE DRAWINGS AND INFORMATION CONTAINED HEREIN ARE THE EXCLUSIVE PROPERTY OF ACTEL.
 THE INFORMATION, DRAWINGS AND DESIGN CONCEPTS CONTAINED HEREIN ARE CONFIDENTIAL/PROPRIETARY. SHALL
 BE MAINTAINED IN STRICT CONFIDENCE, AND SHALL NOT BE RELEASED TO ANY THIRD PARTY WITHOUT THE EXPRESS
 WRITTEN PERMISSION OF ACTEL.

REV. NO.	REV.	DESCRIPTION OF CHANGE	EFFECTIVE DATE	ORIGINATOR
000144	0	Initial	6/6/99	Ray Kuang
2000004	1	change E-tec number to BPW272-1270-20AC11	1/6/2000	Ray Kuang
2000200	2	change socket thickness to 0.10	06/16/2000	Lijie Zhao
2001392	3	add torque limiting screw driver info on page 2, 3 and 4	09/12/2001	Lijie Zhao

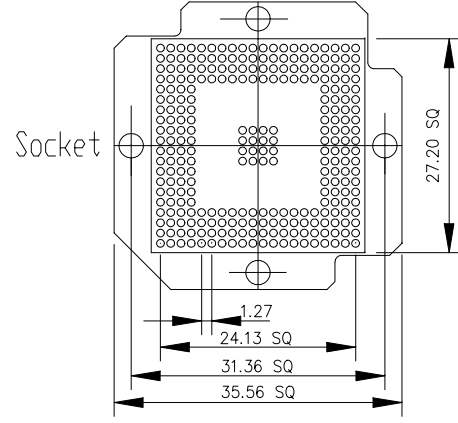
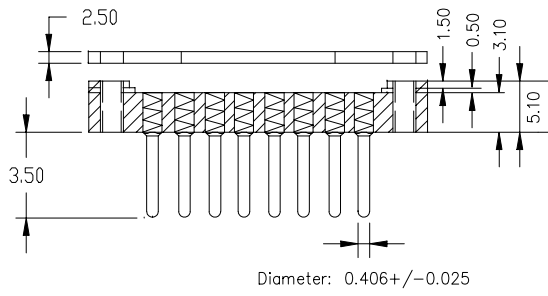

E-TEC PART#: BPW272-1270-20AC11
 E-TEC PATENTS PENDING

NOTES: Dim: mm

- PIN MATERIAL: BRASS ALLOY 360, 1/2 HARD.
- PIN FINISH: 10μ" GOLD OVER 50μ" NICKEL.
- INSULATOR MATERIAL: FR-4 GLASS EPOXY
- Contact: BeCu with gold plated

UNLESS OTHERWISE SPECIFIED DIMENSIONS ARE IN MILLIMETERS		PROJECTION		ACTEL CORP 955 E ARGUES AVE SUNNYVALE CA 94086	
DECIMAL	ANGULAR	APPROVALS		TITLE	
X.X ±0.10	±1°	DATE		272-27 x 27mm, 1.27mm E-TEC BGA SOCKET	
X.XX ±0.05		DRAWN Ray Kuang		VENDOR NAME: E-TEC	
X.XXX ±0.03		CHECKED		ACTEL DWG. NUMBER 1-07-09038	
MATERIAL	SEE NOTES	ENG'R		VENDOR SEQ(PART) NUMBER	
FINISH	SEE NOTES	RELEASED		VENDOR DWG. NUMBER	
DO NOT SCALE DRAWING				Actel Part#: BPW272-1270-20AC11	
				Actel Part#: SE-BG272-A	
				SCALE: NONE	
				SHEET 1 OF 2	

ACTEL CONFIDENTIAL

THE DRAWINGS AND INFORMATION CONTAINED HEREIN ARE THE EXCLUSIVE PROPERTY OF ACTEL.
 THE INFORMATION, DRAWINGS AND DESIGN CONCEPTS CONTAINED HEREIN ARE CONFIDENTIAL/PROPRIETARY, SHALL
 BE MAINTAINED IN STRICT CONFIDENCE, AND SHALL NOT BE RELEASED TO ANY THIRD PARTY WITHOUT THE EXPRESS
 WRITTEN PERMISSION OF ACTEL.

ECN NO.	REV.	DESCRIPTION OF CHANGE	EFFECTIVE DATE	ORIGINATOR
990144	0	Initial	8/8/99	Ray Kiang
9900004	1	change E-tec number to BWP72-1270-22AC11	1/6/2000	Ray Kiang
9900200	2	change socket thickness to 6.10	06/18/2000	Lijie Zhao
2001896	3	add torque limiting screw driver info on page 2, 3 and 4	09/19/2001	Lijie Zhao

ASSEMBLY FLOW

- Retention Frame
- BGA PACKAGE
- BGA SOCKET
SE-BG272-A
- BGA ADAPTER
SOCKET
(see Sn-BG272-B)
- PCB BOARD

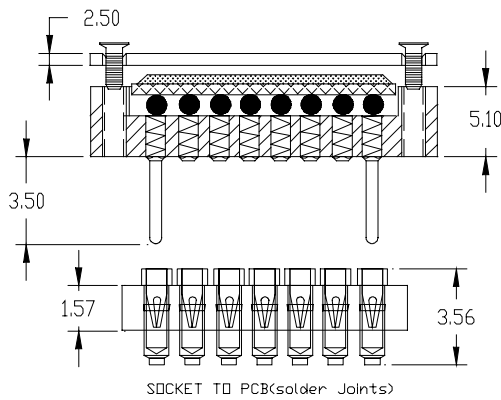

Torque Limiting Screw Driver

Solder past thickness need to be at least 0.20mm(or0.008 inch)
 in order to have reliable solder joint

Note: Dim: mm Please see detail drawing for part number

1. To remove BGA socket from adapter socket, Use removal tool from Mill-Max
2. Mill-Max phone: 516-922-6000
3. Refer E-Tec 'Screw Lock Type Instruction' (on page 3) for more information.
4. Must use torque limiting screw driver to tighten screws (refer Mountz minihaster 020074 gold, preset 7cN.m/10ozf.in on page 4).
 Under torque limit tighten could fall continuity and over torque limit tighten could crack package .

UNLESS OTHERWISE SPECIFIED DIMENSIONS ARE IN MILLIMETERS DECIMAL ANGULAR X.X ±0.10 ±1° X.XX ±0.05 X.XXX ±0.03	PRODUCTION	ACTEL CORP 956 E ARQUES AVE SUNNYVALE CA 94088		
	APPROVALS DATE DRAWN Ray Kiang 4/27/99	TITLE 272-27x27mm, 1.27mm E-TEC BGA SOCKET (272 BGA E-TEC Socket Assembly)		
MATERIAL	CHECKED	VENDOR NAME e-tec	ACTEL DWG NUMBER 1-07-09038	REV 3
FINISH	ENG'D	VENDOR SID(PART) NUMBER	VENDOR DWG NUMBER	REV
SEE NOTES DO NOT SCALE DRAWING	RELEASED	Actel Part#: SE-BG272-A	SCALE: NONB	SHEET 2 OF 2

ACTEL CONFIDENTIAL

Ball / Land Grid Array Sockets

Screw Lock Type

EP patents 0829188, 0897655
 Patents pending in other countries.



E-tec is now the leading BGA socket manufacturer.

Sockets range from 5 x 5 upwards contacts with even larger parts currently in design. Some of the existing patterns are shown on the following pages, many more exist and your exact requirements can easily be added to our extensive product library. The SMD socket is simply placed and reflowed onto the PCB in the same way as the chip and occupies only a small amount of additional board space. The screw lock socket extends $\approx 6,00$ mm beyond the outer ballrow with no fixing holes. We aim to solve your requirements - many different terminals and configurations are available. Your custom sets our standards!

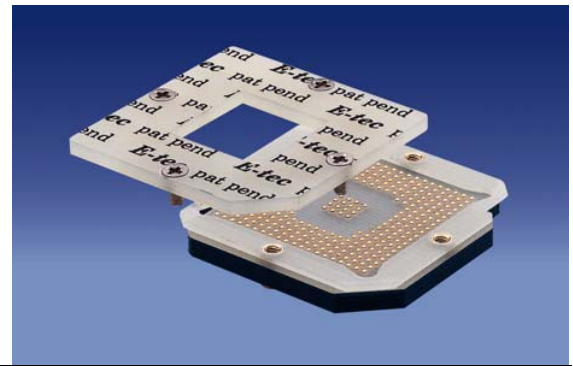

Please note, we will always request the chip data to ensure we offer a compatible socket.

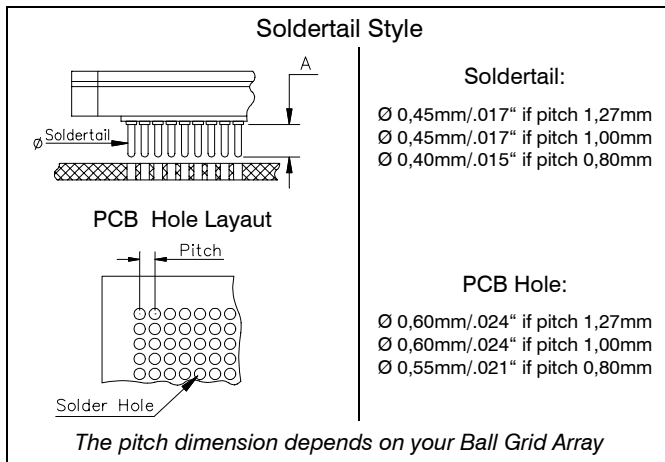
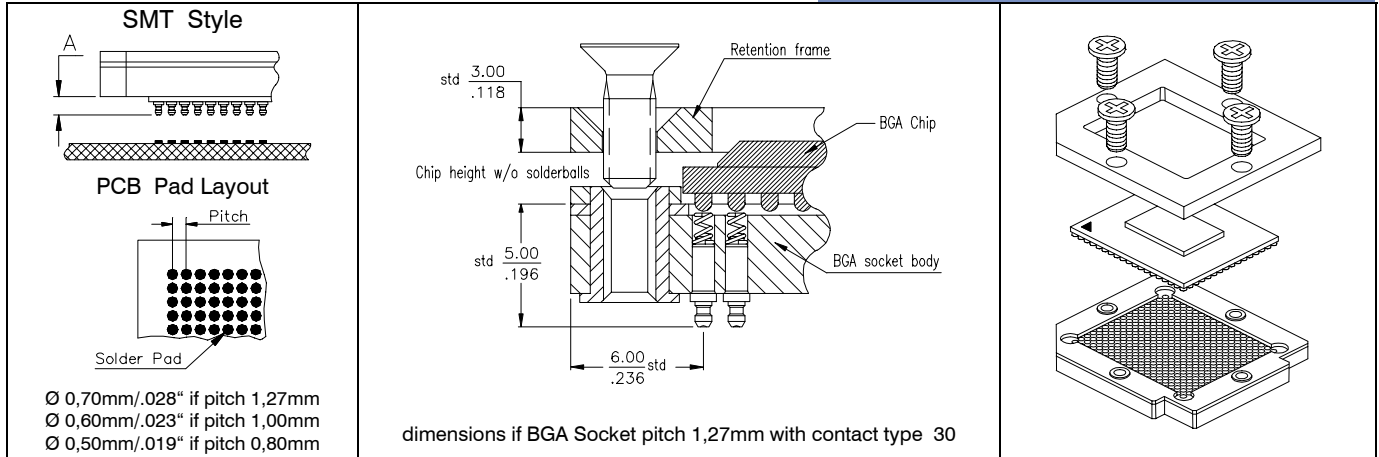

Solder-tail:
 $\varnothing 0,45\text{mm}/.017''$ if pitch 1,27mm
 $\varnothing 0,45\text{mm}/.017''$ if pitch 1,00mm
 $\varnothing 0,40\text{mm}/.015''$ if pitch 0,80mm

PCB Hole:
 $\varnothing 0,60\text{mm}/.024''$ if pitch 1,27mm
 $\varnothing 0,60\text{mm}/.024''$ if pitch 1,00mm
 $\varnothing 0,55\text{mm}/.021''$ if pitch 0,80mm

Specifications	
Mechanical data	
Contact life	100000 cycles min.
Retention System life	100 cycles min.
Solderability	exceeds MIL-STD-202 Method 208
Individual contact force	40 grams max.
Max. torque for retention screws	7 cN per meter, or 10oz per inch
Material	
Insulator	Glass Epoxy FR 4
Terminal	Brass
Contact	BeCu
Electrical data	
Contact resistance	< 30 m Ω
Current rating	1 A max.
Insulation resistance at 500V DC	> 10 ⁴ M Ω
Breakdown voltage at 60 Hz	1 KV min.
Inductance	< 5 nH
Operating temperature	-55°C to +130°C ; 220°C for 10 sec.

How to order

X X W x x x x - x x x x - x x x x x x

Device Type B = Ball Grid L = Land Grid C = Column Grid	Device Material C = Ceramic P = Plastic	Pitch 07 = 0,75mm 08 = 0,80mm 10 = 1,00mm 12 = 1,27mm 15 = 1,50mm	Grid Code <i>please refer to the footprint pages 42 to 50</i>	Config Code <i>will be given by the factory after receipt of the chip datasheet</i>	Plating 01 = tin/gold
Nbr of contacts <i>refer to the next pages</i>		Contact Type 30 = standard SMD („A“ = 1,20mm if 1,27mm pitch; 0,80mm if 1,00mm & 0,80mm pitch) 29 = raised SMD („A“ = 5,00mm; other dim. on request) 70 = solder tail („A“ = 3,30mm if 1,27mm pitch; 2,80mm if 1,00mm & 0,80mm pitch)			

TLS



Torque Screwdrivers Limiting, Internally Adjustable

Designed and manufactured to meet or exceed the accuracy and repeatability requirements of ISO 6789:1992.

Various models that range from 0.7 ozf.in to 120 lbf.in.

Precision radial ball clutch "slips-free" when the preset torque is reached preventing overtorquing.

Thrust bearings insure that the torque setting is independent of any end load applied by the operator.

Tamper-proof internal adjustment.

All models provide bi-directional operation. Available with a one-way clutch system so the screwdriver will operate in one direction but lock solid in the opposite direction for easy screw removal.

Can be clean room modified upon request.

Four different colored lightweight aluminum handles allow color coding of specific torque values in production areas.

Model	1/4" MALE SQUARE DRIVES		1/4" FEMALE HEX DRIVES		Presettable Torque Ranges			Weight	
	Item#	Color	Item#	Color	American	S.I.	Metric	oz.	g.
Micro Minimaster	-	-	020083	Red	3 - 32 ozf.in	2 - 22 cN.m	216 - 2300 gf.cm	1.8	50
Minimaster	-	-	020074	Gold	0.7 - 32 ozf.in	0.5 - 22 cN.m	50 - 2306.2 gf.cm	2.5	72
Minor	020062	Blue	020066	Blue	3 ozf.in - 12 lbf.in	2 - 135 cN.m	200 gf.cm - 14 kgf.cm	7.4	210
	020063	Gold	020067	Gold					
	020064	Green	020068	Green					
	020065	Red	020069	Red					
Standard	020075	Blue	020079	Blue	8 ozf.in - 36 lbf.in	6 - 406 cN.m	600 gf.cm - 40 kgf.cm	9.9	280
	020076	Gold	020080	Gold					
	020077	Green	020081	Green					
	020078	Red	020082	Red					
TLS 1360	020060	Black	020061	Black	10 - 120 lbf.in	113 - 1360 cN.m	11 - 138 kgf.cm	11.5	325