

## FEATURES

- Fully Compliant with the Intel VRM9.0/9.1 VID Specification
- Programs Regulator Output Voltage from 1.10V to 1.85V in 25mV Steps
- Programs an Entire Family of Linear Technology DC/DC Converters
- $\pm 0.25\%$  Accurate Voltage Divider
- Built-In 40k Pull-Up Resistors on Program Inputs
- Available in MSOP-10 Packaging

## APPLICATIONS

- Intel Pentium® III Processor Power Supply
- Multiprocessor Workstations and Servers
- Multiphase Processor Power Supply
- AMD Athlon™ Processor Power Supply

## DESCRIPTION

The LTC®1706-82 is a precision, digitally programmed, resistive ladder which adjusts the output of any 0.8V referenced regulator. Depending on the state of the five VID inputs, an output voltage between 1.10V and 1.85V is programmed in 25mV increments.

The LTC1706-82 is designed specifically to program an entire family of Linear Technology DC/DC converters in full compliance with the Intel VRM9.0/9.1 specifications.

The LTC1706-82 programs the following Linear Technology DC/DC converters: LTC1628, LTC1629, LTC1702, LTC1735, LTC1735-1, LTC1929 and LTC3729.

For a compact VRM9.0/9.1 solution with up to 60A capability, see the LTC3732, a 3-phase synchronous controller with integrated 5-bit VID and MOSFET drivers.

LT, LTC and LT are registered trademarks of Linear Technology Corporation.

Pentium is a registered trademark of Intel Corporation.

AMD Athlon is a trademark of Advanced Micro Devices, Inc.

## TYPICAL APPLICATION

VID Controlled High Current 4-Phase DC/DC Converter (Simplified Block Diagram)

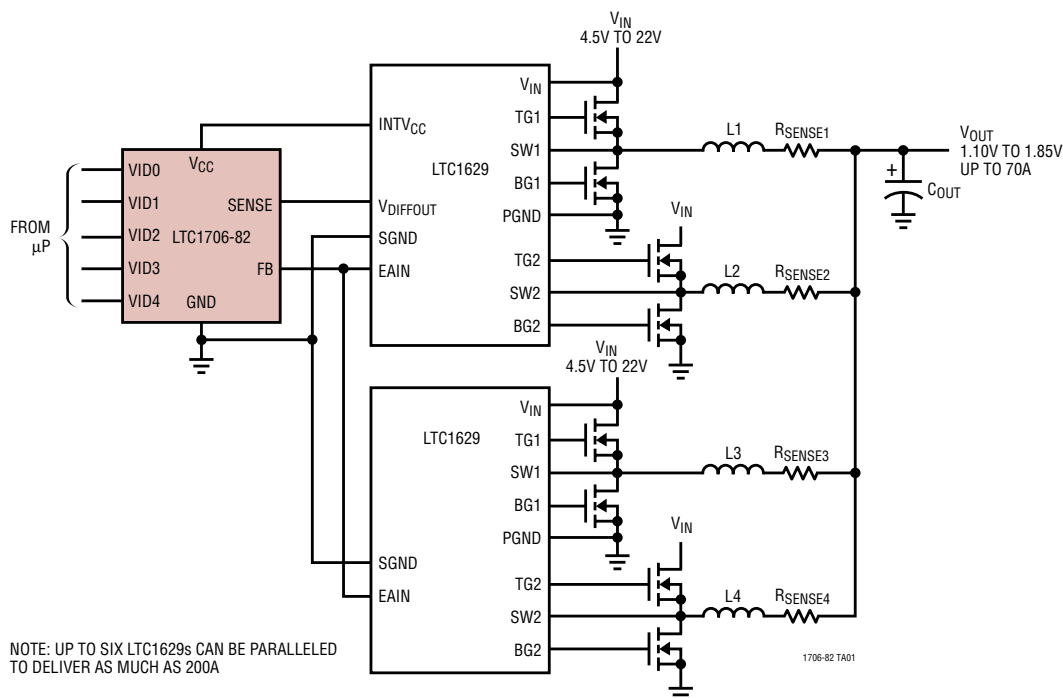

## ABSOLUTE MAXIMUM RATINGS

(Note 1)

(Voltages Referred to GND Pin)

Input Supply Voltage ( $V_{CC}$ ) .....	-0.3V to 7V
VID Input Pins .....	-0.3V to 7V
SENSE Pin .....	-0.3V to 7V
FB Pin .....	-0.3V to 7V
Operating Temperature Range (Note 2) ..	-40°C to 85°C
Junction Temperature .....	110°C
Storage Temperature Range .....	-65°C to 150°C
Lead Temperature (Soldering, 10 sec) .....	300°C

## PACKAGE/ORDER INFORMATION

	ORDER PART NUMBER
	LTC1706EMS-82
	MS PART MARKING
	LTMJ

Consult LTC Marketing for parts specified with wider operating temperature ranges.

## ELECTRICAL CHARACTERISTICS

The ● denotes the specifications which apply over the full operating temperature range, otherwise specifications are at  $T_A = 25^\circ\text{C}$ .  $2.7\text{V} \leq V_{CC} \leq 5.5\text{V}$ ,  $\text{VID0} = \text{VID1} = \text{VID2} = \text{VID3} = \text{VID4} = \text{NC}$  unless otherwise specified.

SYMBOL	PARAMETER	CONDITIONS	MIN	TYP	MAX	UNITS
$V_{CC}$	Operating Supply Voltage Range		2.7		5.5	V
$I_{VCC}$	Supply Current	(Note 3)		0.1	5.0	$\mu\text{A}$
$R_{\text{FB-SENSE}}$	Resistance Between SENSE and FB		● 6	10	14	$\text{k}\Omega$
$V_{\text{OUT Error \%}}$	Output Voltage Accuracy	Programmed From 1.10V to 1.85V	● -0.25		0.25	%
$R_{\text{PULLUP}}$	VID Input Pull-Up Resistance	$V_{\text{DIODE}} = 0.6\text{V}$ , (Note 4)		40		$\text{k}\Omega$
$\text{VID}_T$	VID Input Voltage Threshold	$V_{\text{IL}} (2.7\text{V} < V_{CC} < 5.5\text{V})$ $V_{\text{IH}} (2.7\text{V} < V_{CC} < 5.5\text{V})$	1.6		0.4	V
$I_{\text{VID-LEAK}}$	VID Input Leakage Current	$V_{CC} < \text{VID} < 7\text{V}$ , (Note 4)		0.01	$\pm 1.00$	$\mu\text{A}$
$V_{\text{PULLUP}}$	VID Pull-Up Voltage	$V_{CC} = 3.3\text{V}$ $V_{CC} = 5\text{V}$		2.8	4.5	V

**Note 1:** Absolute Maximum Ratings are those values beyond which the life of a device may be impaired.

**Note 2:** The LTC1706-82 is guaranteed to meet performance specifications from 0°C to 70°C. Specifications over the -40°C to 85°C operating temperature range are assured by design, characterization and correlation with statistical process controls.

**Note 3:** With all five VID inputs floating, the  $V_{CC}$  supply current is simply the device leakage current. However, the  $V_{CC}$  supply current will rise and be approximately equal to the number of grounded VID input pins times  $(V_{CC} - 0.6\text{V})/40\text{k}$ . (See the Applications Information section for more detail.)

**Note 4:** Each built-in pull-up resistor attached to the VID inputs also has a series diode connected to  $V_{CC}$  to allow input voltages higher than the  $V_{CC}$  supply without damage or clamping. (See Operation section for further details.)

# TYPICAL PERFORMANCE CHARACTERISTICS

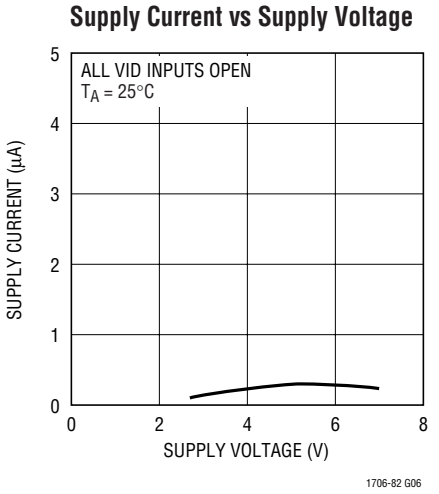
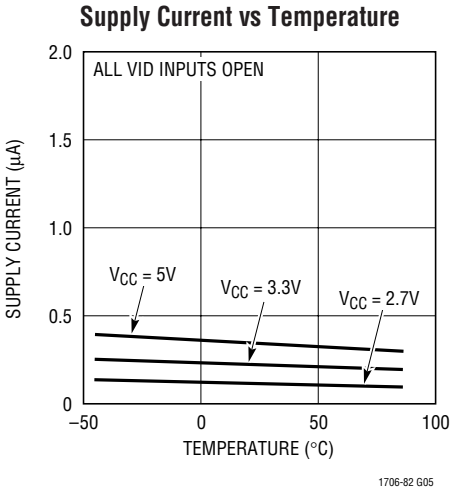
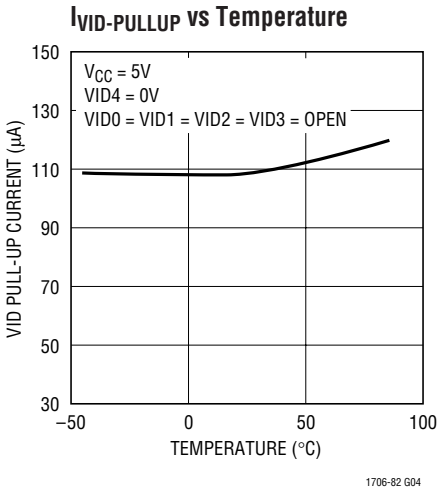
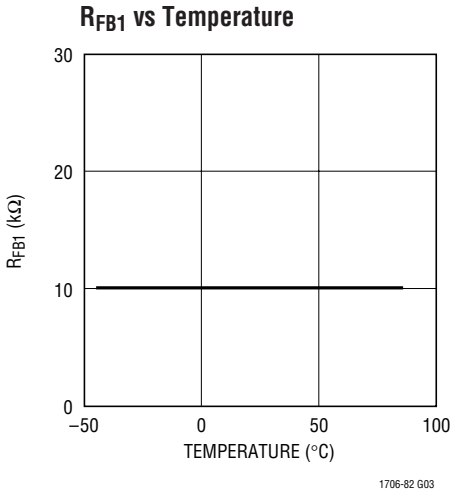
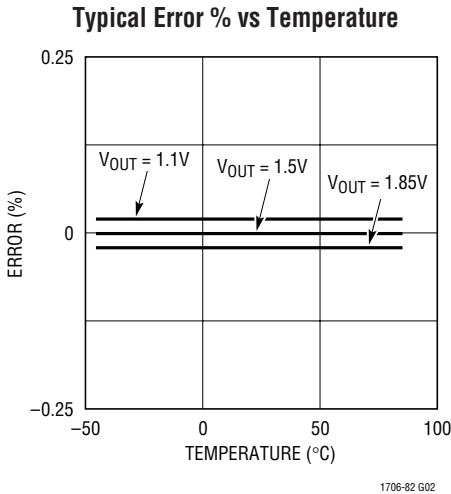
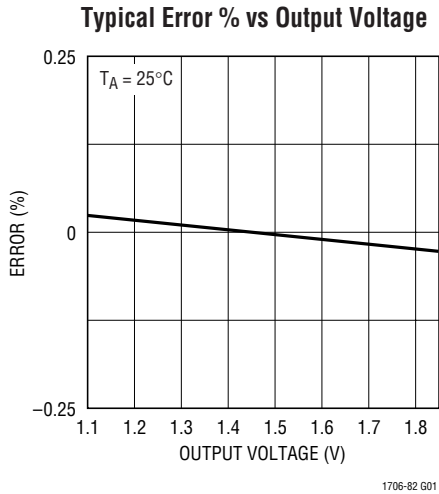

## PIN FUNCTIONS

**VID0 (Pin 1):** LSB Programming Input. Low = GND, High =  $V_{CC}$  or Float. Grounding VID0 adds 25mV to the output sense voltage.

**VID1 (Pin 2):** 4th MSB Programming Input. Low = GND, High =  $V_{CC}$  or Float. Grounding VID1 adds 50mV to the output sense voltage.

**VID2 (Pin 3):** 3rd MSB Programming Input. Low = GND, High =  $V_{CC}$  or Float. Grounding VID2 adds 100mV to the output sense voltage.

**VID3 (Pin 4):** 2nd MSB Programming Input. Low = GND, High =  $V_{CC}$  or Float. Grounding VID3 adds 200mV to the output sense voltage.

**$V_{CC}$  (Pin 5):** Power Supply Voltage. Range from 2.7V to 5.5V.

**SENSE (Pin 6):** Regulator Output Voltage. Connect directly to regulator output sense node or  $V_{DIFFOUT}$  when used with the LTC1629 and LTC1929.

**VID4 (Pin 7):** MSB Programming Input. Low = GND, High =  $V_{CC}$  or Float. Grounding VID4 adds 400mV to the output sense voltage.

**NC (PIN 8):** No Connect.

**GND (Pin 9):** Ground. Connect to regulator signal ground.

**FB (Pin 10):** Feedback Input. Connect to the 0.8V feedback pin of a compatible regulator or the EAIN pin of the LTC1629, LTC1929 and LTC3729.

## PIN TABLE

PIN	NAME	DESCRIPTION	NOMINAL (V)			ABSOLUTE MAX (V)	
			MIN	TYP	MAX	MIN	MAX
1	VID0	LSB Programmable Input	0		$V_{CC}$	-0.3	7
2	VID1	4th MSB Programmable Input	0		$V_{CC}$	-0.3	7
3	VID2	3rd MSB Programmable Input	0		$V_{CC}$	-0.3	7
4	VID3	2nd MSB Programmable Input	0		$V_{CC}$	-0.3	7
5	$V_{CC}$	Power Supply	2.7		5.5	-0.3	7
6	SENSE	Regulator Output Voltage	1.075		1.85	-0.3	7
7	VID4	MSB Programmable Input	0		$V_{CC}$	-0.3	7
8	NC						
9	GND	Ground		0		-0.3	7
10	FB	0.8V Feedback Input	0	0.8	1.075	-0.3	7

## BLOCK DIAGRAM

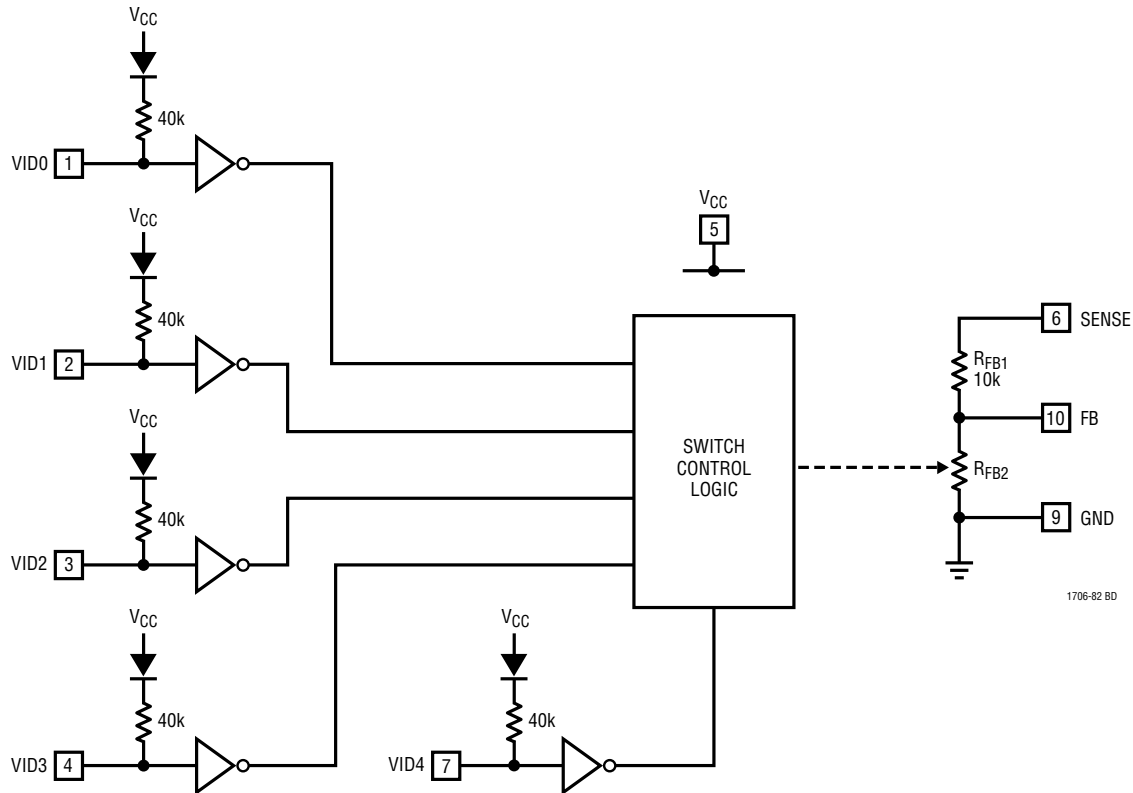

## OPERATION

The LTC1706-82 is a precision resistive divider designed specifically for use with an entire family of Linear Technology Corporation DC/DC switching regulators with 0.8V internal reference and feedback voltages. The LTC1706-82 produces an output voltage ranging from 1.10V to 1.85V in 25mV steps by closing the loop between the output voltage sense and the feedback input of the regulator with the appropriate resistive divider network.

The “top” feedback resistor,  $R_{FB1}$ , connected between SENSE and FB, is typically 10k and is not modified by the state of the VID program inputs.

The “bottom” feedback resistor,  $R_{FB2}$ , however, is modified by the five VID inputs and is precisely ratioed to  $R_{FB1}$ .

### VID Programming

A list of programmed inputs and their corresponding output voltages is shown in Table 1. Programming is accomplished by applying the proper voltage (or float condition) on the five digital VID inputs. VID4 is the most significant bit (MSB) and VID0 is the least significant bit (LSB).

When the five VID inputs are low, or grounded, the regulator output voltage is set to 1.85V. Each increasing binary count is equivalent to a decrease of 25mV in the output voltage. Therefore, to obtain a 1.10V output, only VID0 is grounded while the other four VID inputs are tied high or floating.

When all five VID inputs are high or floating, such as when no CPU is present in a system, a regulated 1.075V output is generated at  $V_{SENSE}$ .

170682fa

## OPERATION

Each VID input pin is pulled up by a 40k resistor in series with a diode connected to  $V_{CC}$ . Therefore, it should be grounded (or driven low) to produce a digital low input. It can be either floated or connected to  $V_{CC}$  to get a digital high input. The series diode is included to prevent the input from being damaged or clamped when it is driven higher than  $V_{CC}$ .

### Voltage Sensing and Feedback Pins

The FB pin is a high impedance node that requires minimum layout distance to reduce extra loading and unwanted stray pickup.

When used with the LTC1629, the LTC1706-82's FB, SENSE,  $V_{CC}$  and GND pins should be connected, respectively, with the EAIN,  $V_{DIFFOUT}$ , INT $V_{CC}$ , and SGND pins of the LTC1629. The result of this application is a precisely controlled, multiphase, variable output voltage supply to any low voltage, high current system such as a powerful personal computer, workstation or network server. True remote sense capability of the LTC1629 is also retained in this case.

### VID Input Characteristics

The VID inputs should be driven with a maximum  $V_{IL}$  of 0.4V and a minimum  $V_{IH}$  of 1.6V. However, the VID input range is not limited to values less than  $V_{CC}$ . Because of the internal diode between  $V_{CC}$  and the pull-up resistor, the inputs can go higher than  $V_{CC}$  without being clamped to  $V_{CC}$  or damaging the input.

This allows the LTC1706-82 to be fully logic compatible and operational over a higher input voltage range (less than the 7V absolute maximum rating).

When a VID input is grounded, there will be a higher quiescent current flow from  $V_{CC}$  because of a resistor from  $V_{CC}$  through a series diode to each one of the VID inputs. This increase in quiescent current is calculated from

$$I_Q = N(V_{CC} - V_{DIODE})/R_{PULLUP}$$

$N$  is the number of grounded VID inputs.  $V_{DIODE}$  is typically 0.6V while  $R_{PULLUP}$  has a typical pullup resistance of 40k.

In other words, each VID input has a typical pull up current of  $(V_{CC} - 0.6)/40K$ , which is approximately 68 $\mu$ A for a 3.3V system.

**Table 1. VID Inputs and Corresponding Output Voltage**

CODE	VID4	VID3	VID2	VID1	VID0	OUTPUT
00000	GND	GND	GND	GND	GND	1.850
00001	GND	GND	GND	GND	Float	1.825
00010	GND	GND	GND	Float	GND	1.800
00011	GND	GND	GND	Float	Float	1.775V
00100	GND	GND	Float	GND	GND	1.750V
00101	GND	GND	Float	GND	Float	1.725V
00110	GND	GND	Float	Float	GND	1.700V
00111	GND	GND	Float	Float	Float	1.675V
01000	GND	Float	GND	GND	GND	1.650V
01001	GND	Float	GND	GND	Float	1.625V
01010	GND	Float	GND	Float	GND	1.600V
01011	GND	Float	GND	Float	Float	1.575V
01100	GND	Float	Float	GND	GND	1.550V
01101	GND	Float	Float	GND	Float	1.525V
01110	GND	Float	Float	Float	GND	1.500V
01111	GND	Float	Float	Float	Float	1.475V
10000	Float	GND	GND	GND	GND	1.450V
10001	Float	GND	GND	GND	Float	1.425V
10010	Float	GND	GND	Float	GND	1.400V
10011	Float	GND	GND	Float	Float	1.375V
10100	Float	GND	Float	GND	GND	1.350V
10101	Float	GND	Float	GND	Float	1.325V
10110	Float	GND	Float	Float	GND	1.300V
10111	Float	GND	Float	Float	Float	1.275V
11000	Float	Float	GND	GND	GND	1.250V
11001	Float	Float	GND	GND	Float	1.225V
11010	Float	Float	GND	Float	GND	1.200V
11011	Float	Float	GND	Float	Float	1.175V
11100	Float	Float	Float	GND	GND	1.150V
11101	Float	Float	Float	GND	Float	1.125V
11110	Float	Float	Float	Float	GND	1.100V
11111	Float	Float	Float	Float	Float	NO_CPU (1.075V)

## APPLICATIONS INFORMATION

Besides the LTC1629, the LTC1706-82 also programs a whole family of LTC DC/DC converters that have an onboard 0.8V reference. The LTC1628, LTC1735, LTC1702, LTC1772, LTC1929 and LTC3729 are just a few of the high efficiency step-down switching regulators that will work equally well with the LTC1706-82.

## PACKAGE DESCRIPTION

**MS Package**  
**10-Lead Plastic MSOP**  
 (Reference LTC DWG # 05-08-1661)

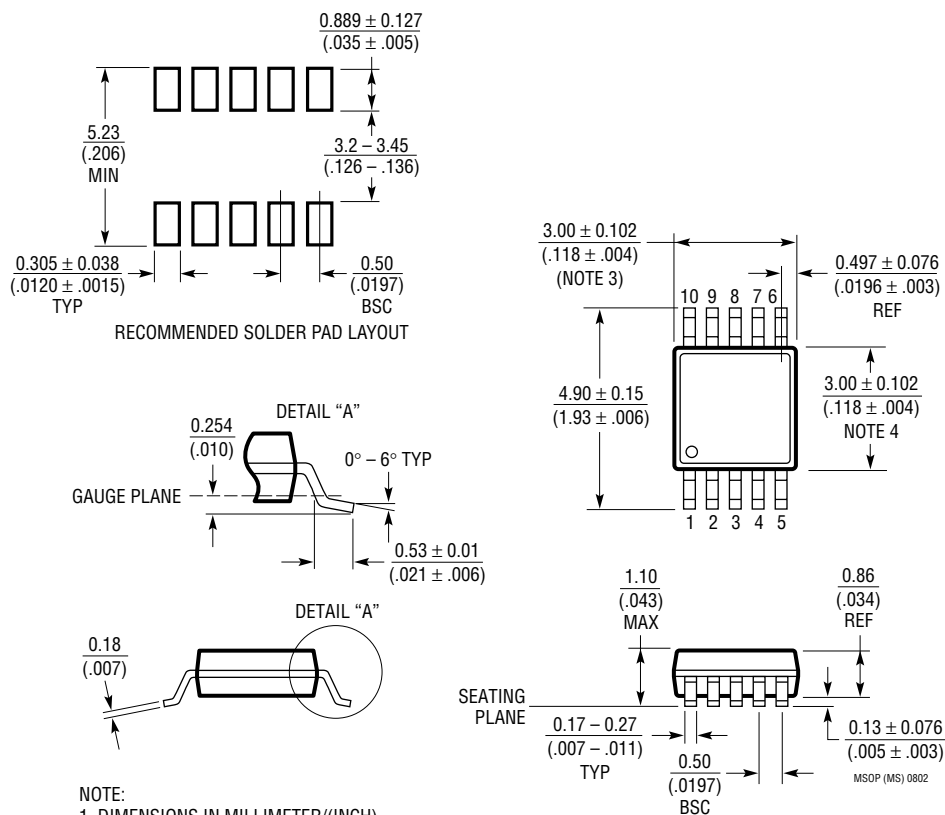

**NOTE:**

1. DIMENSIONS IN MILLIMETER/(INCH)
2. DRAWING NOT TO SCALE
3. DIMENSION DOES NOT INCLUDE MOLD FLASH, PROTRUSIONS OR GATE BURRS.  
MOLD FLASH, PROTRUSIONS OR GATE BURRS SHALL NOT EXCEED 0.152mm (.006") PER SIDE
4. DIMENSION DOES NOT INCLUDE INTERLEAD FLASH OR PROTRUSIONS.  
INTERLEAD FLASH OR PROTRUSIONS SHALL NOT EXCEED 0.152mm (.006") PER SIDE
5. LEAD COPLANARITY (BOTTOM OF LEADS AFTER FORMING) SHALL BE 0.102mm (.004") MAX

## TYPICAL APPLICATION

### VID Controlled High Current 70A 4-Phase Power Supply

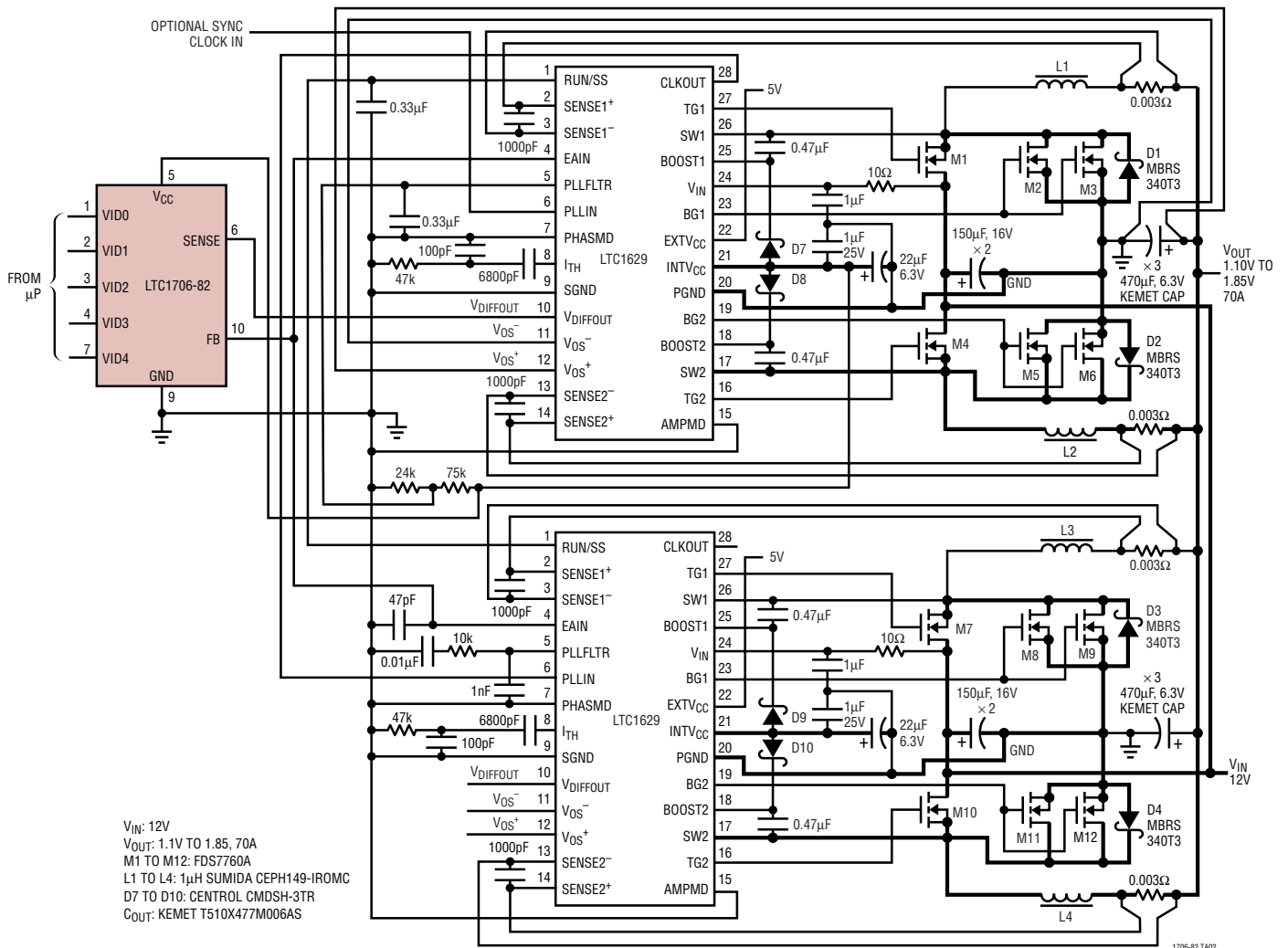

## RELATED PARTS

PART NUMBER	DESCRIPTION	COMMENTS
LTC1628/LTC1628-PG	Dual High Efficiency, 2-Phase Sync Step-Down Controller	Constant Freq, Standby, 5V and 3.3V LDOs, $3.5V \leq V_{IN} \leq 36V$
LTC1629/LTC1629-PG	PolyPhase <sup>®</sup> High Efficiency Step-Down DC/DC Controller	Expandable Up to 12 Phases, Up to 200A, Remote Sense Diff Amp
LTC1702/LTC1703	Dual High Efficiency, 2-Phase Sync Step-Down Controller	550kHz, 25MHz GBW, No $R_{SENSE}^{TM}$ , $2.7V \leq V_{IN} \leq 7V$
LTC1706-81	VID Voltage Programmer with Desktop Code	VRM 8.2-VRM 8.4, $V_{OUT}$ Range: 1.3V to 3.5V
LTC1709/LTC1709-8	2-Phase Sync Step-Down Controller with 5-Bit Desktop VID	$4V \leq V_{IN} \leq 36V$ , PLL, 36-Pin SSOP, Current Mode Operation
LTC1735	High Efficiency Sync Step-Down Controller	Burst Mode Operation, 16-Pin Narrow SSOP, Fault Protection, $3.5V \leq V_{IN} \leq 36V$
LTC1736	High Efficiency Sync Buck Controller with 5-Bit Mobile VID	GN-24, Power Good, Output Fault Protection, $3.5V \leq V_{IN} \leq 36V$
LTC1772	SOT-23 Low Voltage Step-Down Controller	6-Pin SOT-23, $2.5V \leq V_{IN} \leq 10V$ , 550kHz, Burst Mode <sup>®</sup> Operation
LTC1929/LTC1929-PG	2-Phase Sync Step-Down Controller	Current Mode Operation, $I_{OUT}$ Up to 40A, $3.5V \leq V_{IN} \leq 36V$
LTC3732	3-Phase, 5-Bit VID, Synchronous Step-Down Controller	$I_{OUT} \leq 60A$ , VRM9.0/9.1 Compatible, 600kHz per Phase Operation, Integrated MOSFET Drivers.

Burst Mode and PolyPhase are registered trademarks of Linear Technology Corporation. No  $R_{SENSE}$  is a trademark of Linear Technology Corporation.

170682fa