

HLMP-CWxx

T-1³/₄ Precision Optical Performance
White LED Lamps



Data Sheet

HLMP-CW15, HLMP-CW16, HLMP-CW23, HLMP-CW24,
HLMP-CW30, HLMP-CW31, HLMP-CW70, HLMP-CW72



Description

These high intensity white LED lamps are based on InGaN material technology. A blue LED die is coated by a phosphor to produce white. The typical resulting color is described by the coordinates $x = 0.32$, $y = 0.32$ using the 1931 CIE Chromaticity Diagram.

These T-1³/₄ lamps are untinted, nondiffused, and incorporate precise optics producing well defined spatial radiation patterns at specific viewing cone angle.

Features

- Highly luminous white emission
- 15°, 23°, 30°, and 70° viewing angle

Applications

- Electronic signs and signals
- Small area illumination
- Legend backlighting
- General purpose indicators

Benefit

- Reduced power consumption, higher reliability, and increased optical/mechanical design flexibility compared to incandescent bulbs and other alternative white light sources

CAUTION: These devices are Class 1C ESD sensitive. Please observe appropriate precautions during handling and processing. Refer to Avago Technologies Application Note AN-1142 for additional details.

Device Selection Guide

Part Number	Viewing Angle Typ.	Min. Luminous Intensity Iv (mcd) @ 20 mA		Standoff Leads	Package Dimension
		Min.	Max.		
HLMP-CW15-TW0xx	15°	2500	7200	No	A
HLMP-CW15-TW0xx	15°	2500	7200	No	A
HLMP-CW15-UV0xx	15°	3200	5500	No	A
HLMP-CW15-VWBxx	15°	4200	7200	No	A
HLMP-CW15-VY0xx	15°	4200	12000	No	A
HLMP-CW15-VYBxx	15°	4200	12000	No	A
HLMP-CW15-VYGxx	15°	4200	12000	No	A
HLMP-CW15-VYKxx	15°	4200	12000	No	A
HLMP-CW16-R00xx	15°	1500	-	Yes	B
HLMP-CW16-TW0xx	15°	2500	7200	Yes	B
HLMP-CW16-VY0xx	15°	4200	12000	Yes	B
HLMP-CW23-SV0xx	23°	1900	5500	No	A
HLMP-CW23-SVKxx	23°	1900	5500	No	A
HLMP-CW23-TW0xx	23°	2500	7200	No	A
HLMP-CW24-SV0xx	23°	1900	5500	Yes	B
HLMP-CW24-TW0xx	23°	2500	7200	Yes	B
HLMP-CW30-PS0xx	30°	880	2500	No	A
HLMP-CW30-RU0xx	30°	1500	4200	No	A
HLMP-CW30-STBxx	30°	1900	3200	No	A
HLMP-CW30-SV0xx	30°	1900	5500	No	A
HLMP-CW31-M00xx	30°	520	-	Yes	B
HLMP-CW31-PS0xx	30°	880	2500	Yes	B
HLMP-CW31-SV0xx	30°	1900	5500	Yes	B
HLMP-CW70-LMBxx	70°	400	680	No	A
HLMP-CW70-LP0xx	70°	400	1150	No	A
HLMP-CW72-LP0xx	70°	400	1150	Yes	B

Tolerance for each intensity limit is ±15%.

Package Dimensions

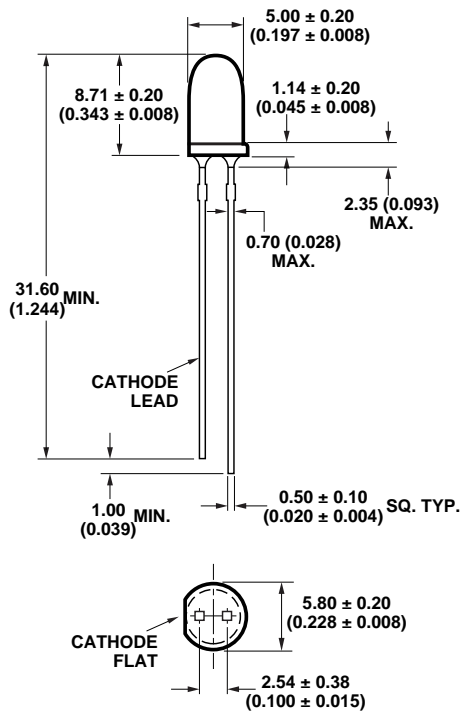

PACKAGE DIMENSION A

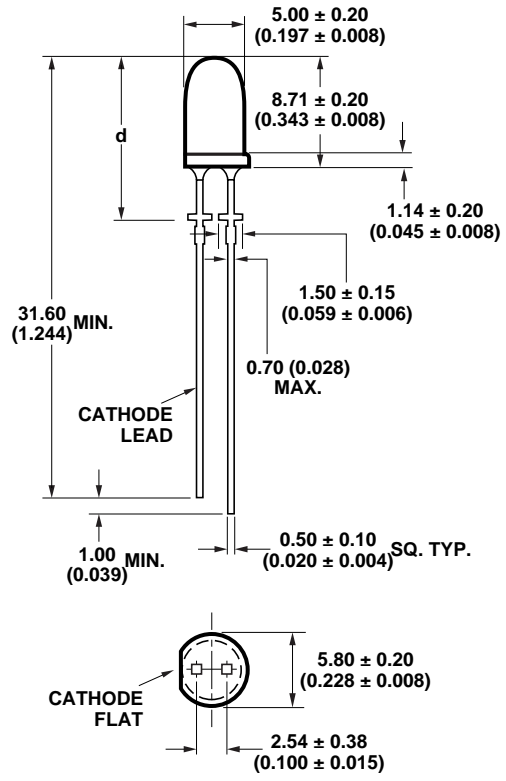

PACKAGE DIMENSION B

NOTES:

1. ALL DIMENSIONS ARE IN MILLIMETERS (INCHES).
2. EPOXY MENISCUS MAY EXTEND ABOUT 1 mm (0.040") DOWN THE LEADS.

HLMP-CW16	HLMP-CW24	HLMP-CW31	HLMP-CW72
d = 12.6 ± 0.25 (0.496 ± 0.010)	d = 12.52 ± 0.25 (0.493 ± 0.010)	d = 11.96 ± 0.25 (0.471 ± 0.010)	d = 12.52 ± 0.25 (0.493 ± 0.010)

Part Numbering System

HLMP - CWxx - x x x xx

Mechanical Option

00: Bulk
DD: Ammo Pack

Color Bin Option

0: Full color bin distribution
B: Color bins 2 & 3
G: Color bins 2, 3 & 4
K: Color bins 2 & 4

Maximum Intensity Bin Limit

0: No maximum intensity bin limit
Others: Refer to Device Selection Guide

Minimum Intensity Bin Limit

Refer to Device Selection Guide

Viewing Angle and Standoff Option

15: 15° without standoffs
16: 15° with standoffs
23: 23° without standoffs
24: 23° with standoffs
30: 30° without standoffs
31: 30° with standoffs
70: 50° without standoffs
72: 50° with standoffs

Absolute Maximum Ratings

T_A = 25°C

Parameter	Value	Units
DC Forward Current ^[1]	30	mA
Peak Forward Current ^[2]	100	mA
Power Dissipation	111	mW
Reverse Voltage (I _R = 10 μA)	5	V
LED Junction Temperature	110	°C
Operating Temperature Range	-40 to +80	°C
Storage Temperature Range	-40 to +100	°C

Notes:

1. Derate linearly as shown in Figure 5.
2. Duty factor 10%, 1 kHz.

Electrical Characteristics

T_A = 25°C

Forward Voltage, V _F (V) @ I _F = 20 mA		Reverse Breakdown, V _R (V) @ I _R = 10 μA	Capacitance, C (pF), V _F = 0, f = 1 MHz	Thermal Resistance R _{θJ-PIN} (°C/W)
Typ.	Max.	Min.	Typ.	Typ.
3.2	3.7	5	70	240

Optical Characteristics

T_A = 25°C

Part Number	Typical Chromaticity Coordinates ^[1]		Viewing Angle 2θ _{1/2} Degrees ^[2]
	X	Y	Typ.
HLMP-CW3x-xxxxx	0.32	0.32	30
HLMP-CW2x-xxxxx	0.32	0.32	23
HLMP-CW1x-xxxxx	0.32	0.32	15
HLMP-CW7x-xxxxx	0.32	0.32	50

Notes:

1. The chromaticity coordinates are derived from the CIE 1931 Chromaticity Diagram and represent the perceived color of the device.
2. θ_{1/2} is the off-axis angle where the luminous intensity is 1/2 the peak intensity.

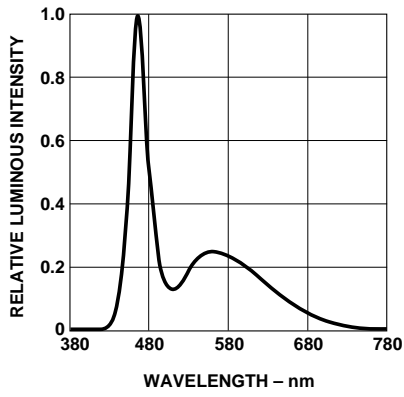

Figure 1. Relative intensity vs. wavelength

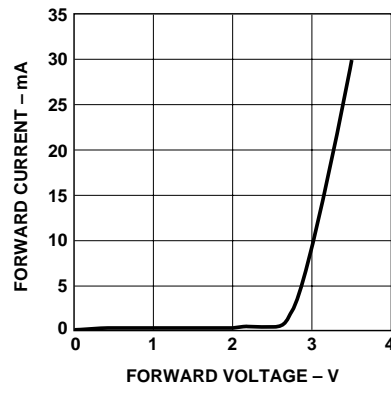

Figure 2. Forward current vs. forward voltage

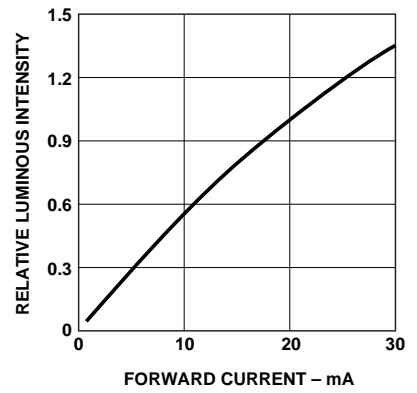

Figure 3. Relative intensity vs. forward current

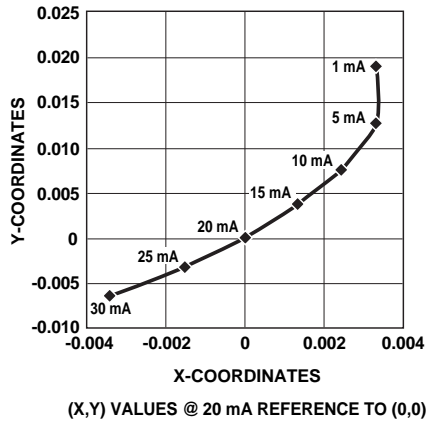

Figure 4. Chromaticity shift vs. current

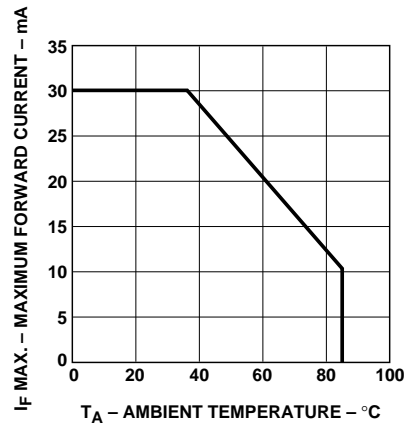

Figure 5. Maximum forward current vs. temperature

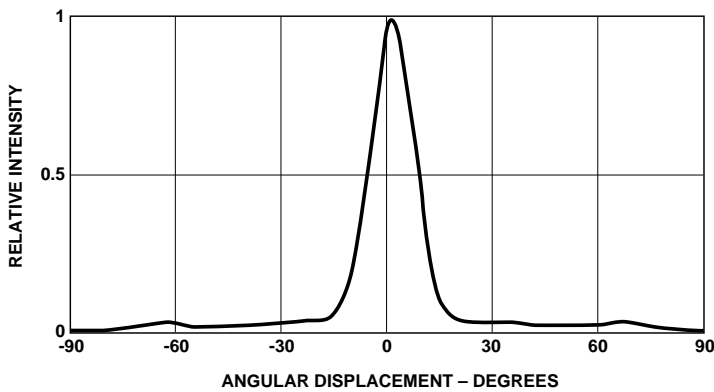

Figure 6a. CW1x spatial radiation pattern

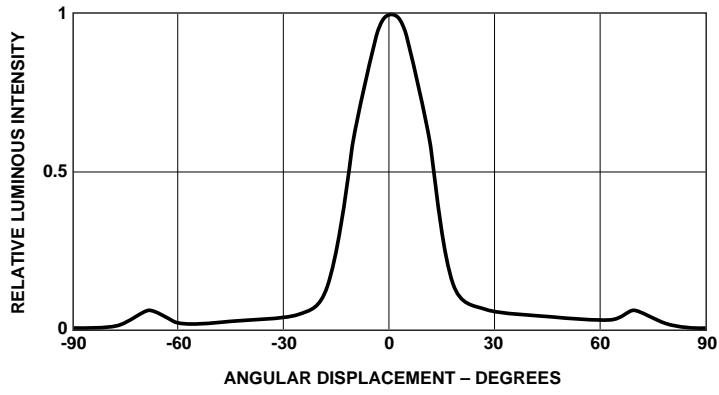

Figure 6b. CW2x spatial radiation pattern

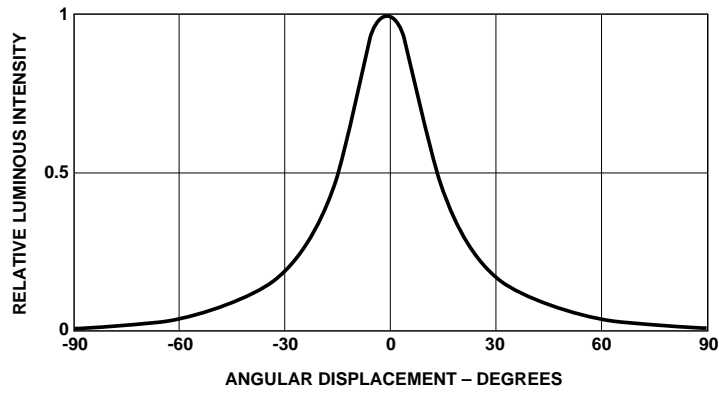

Figure 6c. CW3x spatial radiation pattern

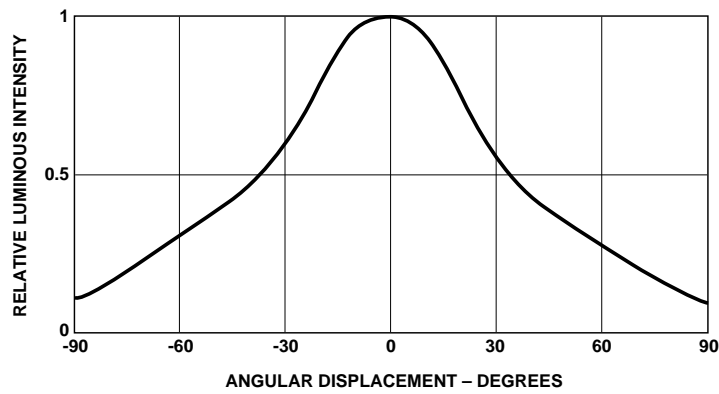

Figure 6c. CW7x spatial radiation pattern

Intensity Bin Limits (mcd at 20 mA)

Bin	Min.	Max.
L	400	520
M	520	680
N	680	880
P	880	1150
Q	1150	1500
R	1500	1900
S	1900	2500
T	2500	3200
U	3200	4200
V	4200	5500
W	5500	7200
X	7200	9300
Y	9300	12000
Z	12000	16000

Tolerance for each bin limit is $\pm 15\%$.

Color Bin Limit Table

Rank	Limits (Chromaticity Coordinates)				
1	x	0.330	0.330	0.356	0.361
	y	0.360	0.318	0.351	0.385
2	x	0.287	0.296	0.330	0.330
	y	0.295	0.276	0.318	0.339
3	x	0.264	0.280	0.296	0.283
	y	0.267	0.248	0.276	0.305
4	x	0.283	0.287	0.330	0.330
	y	0.305	0.295	0.339	0.360

Tolerance for each bin limit is ± 0.01 .

Note:

Bin categories are established for classification of products. Products may not be available in all bin categories. Please contact your Avago representative for information on currently available bins.

Color Bin Limits with Respect to CIE 1931 Chromaticity Diagram

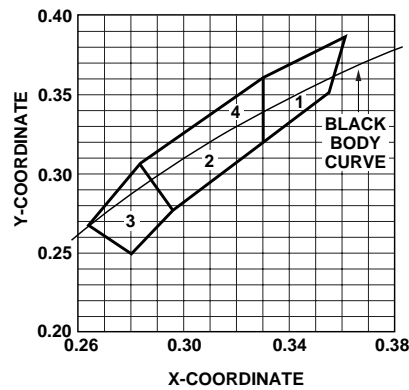

Relative Light Output vs. Junction Temperature

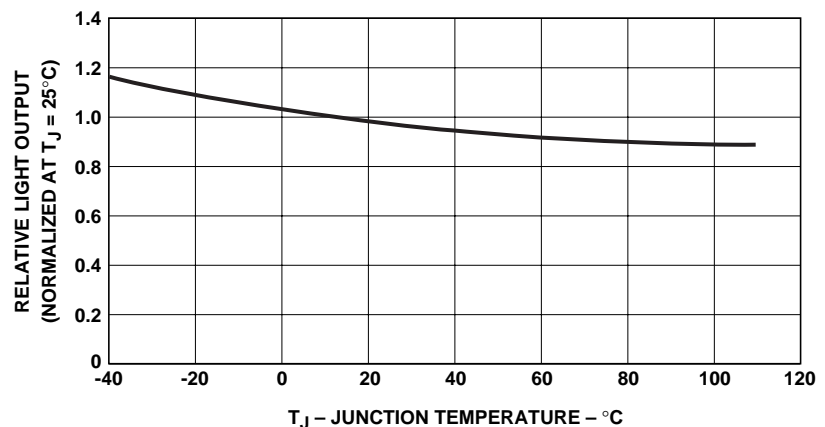

Precautions:

Lead Forming

- The leads of an LED lamp may be preformed or cut to length prior to insertion and soldering into PC board.
- If lead forming is required before soldering, care must be taken to avoid any excessive mechanical stress induced into the LED package. Otherwise, cut the leads of LED to length after soldering process at room temperature. The solder joint formed will absorb the mechanical stress of the lead cutting from traveling to the LED chip die attach and wirebond.
- For better control, it is recommended to use proper tool to precisely form and cut the leads to applicable length rather than doing it manually.

Soldering Conditions

- Care must be taken during PCB assembly and soldering process to prevent damage to the LED component.
- The closest manual soldering distance of the soldering heat source (soldering iron’s tip) to the body is 1.59 mm. Soldering the LED closer than 1.59 mm might damage the LED.

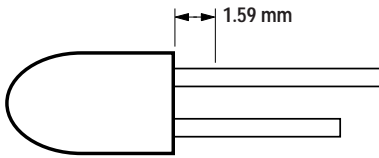

- Recommended soldering conditions:

	Wave Soldering	Manual Solder Dipping
Pre-heat Temperature	105 °C Max.	–
Pre-heat Time	30 sec Max.	–
Peak Temperature	250 °C Max.	260 °C Max.
Dwell Time	3 sec Max.	5 sec Max.

- Wave soldering parameter must be set and maintained according to recommended temperature and dwell time in the solder wave. Customer is advised to daily check on the soldering profile to ensure that the soldering profile is always conforming to recommended soldering condition.

Notes:

1. PCB with different size and design (component density) will have different head mass (heat capacity). This might cause a change in temperature experienced by the board if same wave soldering setting is used. So, it is recommended to recalibrate the soldering profile again before loading a new type of PCB.

2. Avago Technologies' high brightness LED are using high efficiency LED die with single wire bond as shown below. Customer is advised to take extra precaution during wave soldering to ensure that the maximum wave temperature is not exceeding 250°C. Overstressing the LED during soldering process might cause premature failure to the LED due to delamination.

Avago Technologies LED Configuration

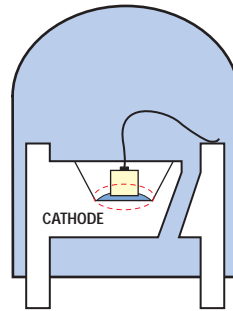

InGaN Device

Note: Electrical connection between bottom surface of LED die and the lead frame material through conductive paste of solder.

- If necessary, use fixture to hold the LED component in proper orientation with respect to the PCB during soldering process.
- At elevated temperature, the LED is more susceptible to mechanical stress. Therefore, PCB must be allowed to cool down to room temperature prior to handling, which includes removal of jigs, fixtures or pallet.
- Special attention must be given to board fabrication, solder masking, surface plating and lead holes size and component orientation to assure solderability.
- Recommended PC board plated through hole sizes for LED component leads:

LED Component Lead Size	Diagonal	Plated Through Hole Diameter
0.457 x 0.457 mm (0.018 x 0.018 inch)	0.646 mm (0.025 inch)	0.976 to 1.078 mm (0.038 to 0.042 inch)
0.508 x 0.508 mm (0.020 x 0.020 inch)	0.718 mm (0.028 inch)	1.049 to 1.150 mm (0.041 to 0.045 inch)

- Over sizing of plated through hole can lead to twisting or improper LED placement during auto insertion. Under sizing plated through hole can lead to mechanical stress on the epoxy lens during clinching.

Note: Refer to Application Note AN1027 for more information on soldering LED components.

Recommended Wave Soldering Profile

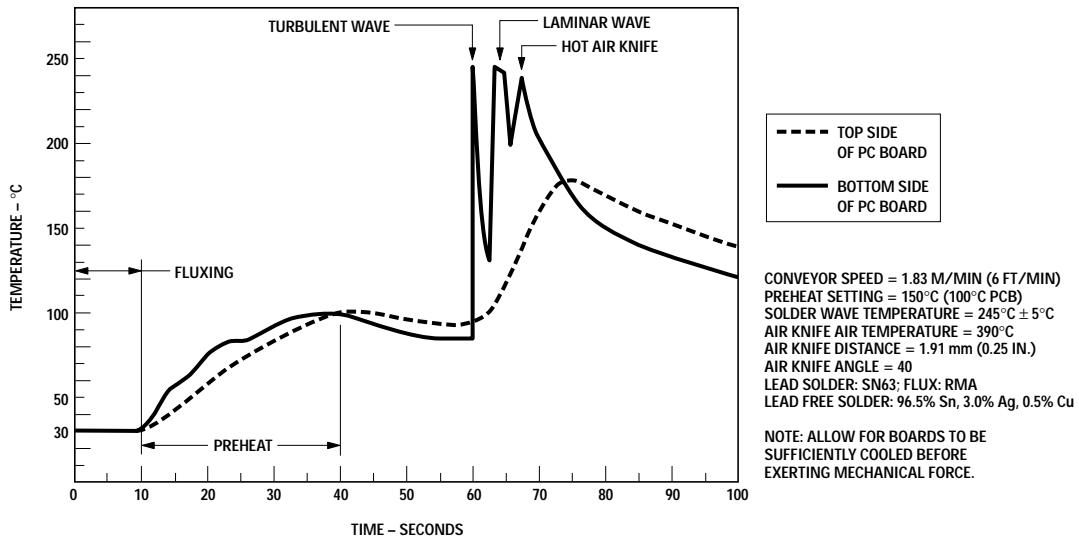

Ammo Packs Drawing

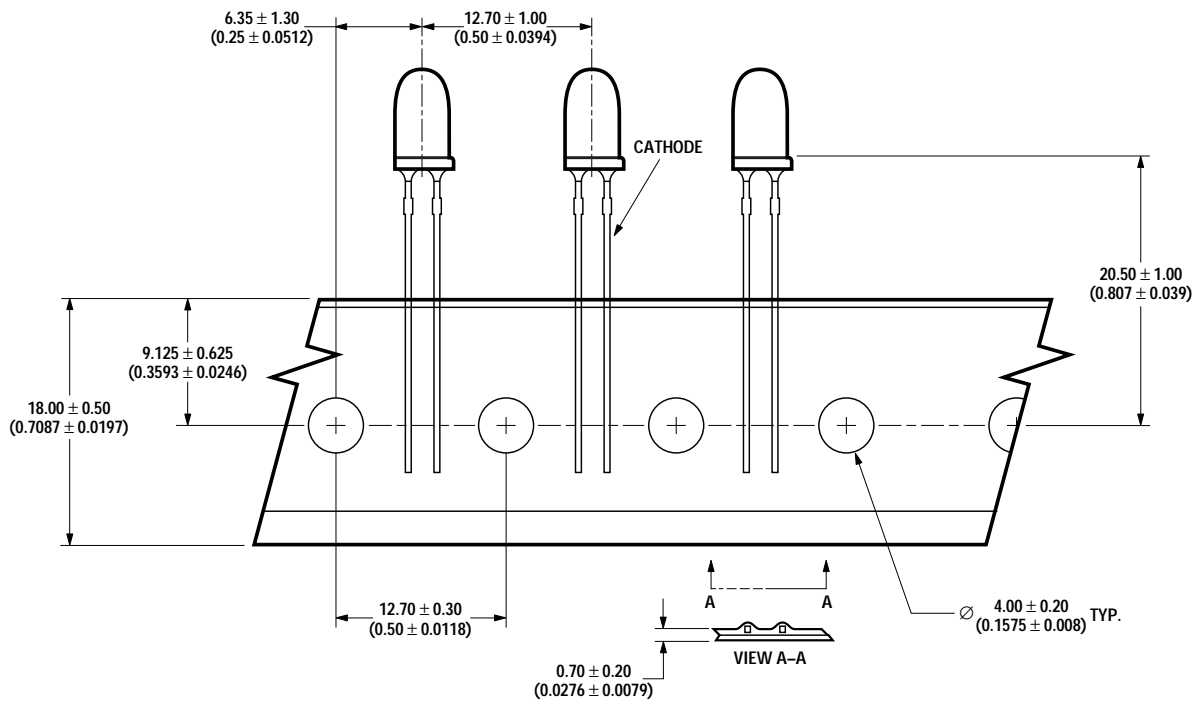

ALL DIMENSIONS IN MILLIMETERS (INCHES).

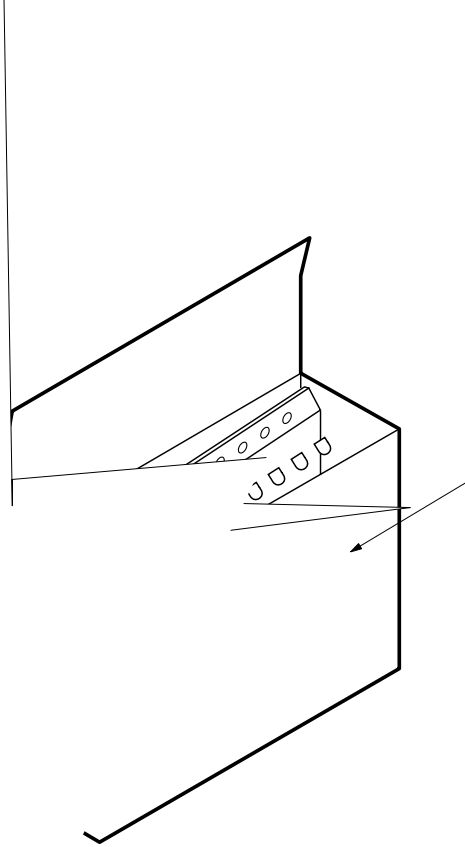

For product information and a complete list of distributors, please go to our website: www.avagotech.com

Avago, Avago Technologies, and the A logo are trademarks of Avago Technologies Limited in the United States and other countries.
Data subject to change. Copyright © 2007 Avago Technologies Limited. All rights reserved. Obsoletes 5989-4125EN
AV02-0214EN April 2, 2007

AVAGO
TECHNOLOGIES