

# S Series Multifunction DAQ 12 or 16-Bit, 1 to 10 MS/s, 4 Analog Inputs

## NI 6120, NI 6115, NI 6110, NI 6111

- 2 or 4 analog inputs; dedicated A/D converter per channel
- 1 to 10 MS/s per channel maximum sample rate
- Analog and digital triggering
- AC or DC coupling
- 8 input ranges from  $\pm 200$  mV to  $\pm 42$  V
- 2 analog outputs at 4 MS/s single channel or 2.5 MS/s dual channel
- 8 digital I/O lines (5 V TTL/CMOS)
- Two 24-bit counter/timers
- Measurement services that simplify configuration and measurements

### Operating Systems

- Windows 2000/NT/XP
- Mac OS X
- Linux

### Recommended Software

- LabVIEW 7.x or higher
- LabWindows/CVI 7.x or higher
- Measurement Studio 7.x or higher
- Digital Waveform Editor
- SignalExpress 1.x or higher

### Other Compatible Software

- VI Logger 2.x or higher
- Visual Studio .NET
- Visual Basic, C/C++, and C#

### Measurement Services Software (included)<sup>1</sup>

- NI-DAQmx driver software
- Measurement & Automation Explorer configuration utility
- VI Logger Lite data-logging software

<sup>1</sup>Mac OS X and Linux applications must use NI-DAQmx Base driver software.



Calibration Certificate Available

Family	Bus	Analog Inputs	Input Resolution (bits)	Sampling Rate (MS/s)	Input Range (V)	Analog Outputs	Max Output Rate (MS/s)	Output Range (V)	Digital I/O	Counter/Timers	Triggers
NI 6120	PCI, PXI	4	16	1 <sup>3</sup>	$\pm 0.2$ to $\pm 42$	2	4 <sup>1</sup>	$\pm 10$	8 <sup>2</sup>	2, 24-bit	Analog, digital
NI 6115	PCI, PXI	4	12	10	$\pm 0.2$ to $\pm 42$	2	4 <sup>1</sup>	$\pm 10$	8 <sup>2</sup>	2, 24-bit	Analog, digital
NI 6110	PCI	4	12	5	$\pm 0.2$ to $\pm 42$	2	4 <sup>1</sup>	$\pm 10$	8	2, 24-bit	Analog, digital
NI 6111	PCI	2	12	5	$\pm 0.2$ to $\pm 42$	2	4 <sup>1</sup>	$\pm 10$	8	2, 24-bit	Analog, digital

<sup>1</sup>4 MS/s single channel; 2.5 MS/s on two channels <sup>2</sup>Hardware-timed up to 10 MB/s <sup>3</sup>900 kS/s with NI-DAQmx, 1 MS/s with additional download. Special conditions apply.

Table 1. Channel, Speed, and Resolution Specifications

## Overview and Applications

National Instruments S Series devices combine the latest in PC technologies to deliver simultaneous-sampling, high-bandwidth capabilities for low and high-channel-count data acquisition and control systems. Use S Series devices in a variety of applications including:

- Stimulus/response applications where synchronization among high-speed analog input (AI), analog output (AO), and digital I/O is required
- 42 V automotive applications
- Radar, sonar, ultrasound
- Transient/ballistics measurements
- High-energy physics
- IF digitization

## Features

The NI high-performance S Series DAQ devices have the same basic features of a typical multifunction device – eight digital I/O lines, two counter/timers, two analog outputs, RTSI or PXI trigger bus for multidevice synchronization, and PFI lines for software-controlled routing of timing and triggering signals. S Series devices exceed the analog input performance of traditional multiplexed devices with features including:

Family	Onboard Memory (samples)	Antialias Filters <sup>1</sup>	Signal Coupling	Input Configuration	DIO
NI 6120	64 M	5-pole Bessel, 100 kHz	AC and DC	Pseudodifferential	Hardware-timed
NI 6115	32 M or 64 M	3-pole Bessel 50 and 500 kHz	AC and DC	Pseudodifferential	Hardware-timed
NI 6110	8,192	–	DC	Pseudodifferential	Software-timed
NI 6111	8,192	–	DC	Pseudodifferential	Software-timed

<sup>1</sup>Filter can be bypassed.

Table 2. Special Features



# S Series Multifunction DAQ 12 or 16-Bit, 1 to 10 MS/s, 4 Analog Inputs

**Dedicated A/D Converters per Channel** – help you achieve faster sampling rates per channel, simultaneous sampling, and better dynamic accuracy for transient or frequency measurements.

**200 mV to 42 V Input Ranges** – configure each analog input channel to read from a very wide variety of voltage ranges. The input impedance is lower for 20 and 42 V ranges, preserving the bandwidth for signals with high frequencies and large amplitudes.

**AC or DC Coupling** – configure analog inputs for AC or DC coupling on a per-channel basis. AC coupling removes the DC offset for applications only analyzing signals in the frequency domain.

**Antialias Filters (NI 6115 and NI 6120)** – the antialias filters are turned on from software on a per-channel basis. NI 6115 devices have 50 or 500 kHz filters for each channel, and NI 6120 devices have 100 kHz filters for each channel.

**Large Onboard Memory (NI 6115 and NI 6120)** – NI 6120 devices feature a 64 MS onboard memory, and NI 6115 devices feature a 64 or 32 MS onboard memory. With the extra memory, which requires no extra programming, you can capture high-bandwidth signals over long periods of time, even if multiple devices are sharing the same PCI or PXI bus.

**Hardware-Timed Digital I/O** – the digital I/O lines can synchronize with the analog input, analog output, counter/timer I/O, or an external clock for mixed-signal measurement applications. Using the onboard FIFO, you can achieve reliable data transfers to 10 MB/s.

**Phase Locking (PXI only)** – synchronize multiple devices to a common PXI backplane clock to preserve the phase between measurements across multiple device analog input channels.

## Professional Analysis and Presentation Toolkits

There are several analysis and presentation add-on toolkits available from National Instruments that help make you more productive when developing custom applications with your S Series devices. Turn your S Series device into a transient recorder, spectrum analyzer, or one of several other instruments with these toolkits.

## NI LabVIEW Sound and Vibration Toolkit

This toolkit includes a full set of frequency-domain analysis and presentation tools required for sound and vibration applications. These tools include:

- Distortion, gain, phase, cross-talk, and dynamic range measurements
- Octave analysis
- Swept-sine analysis
- Linear, exponential, and peak hold measurements
- Baseband and zoom FFT, power, FFT, power spectral density (PSD)
- Limit testing
- Short-time Fourier transform and shock response spectrum
- Weighting filters
- System calibration
- Waterfall/colormap display

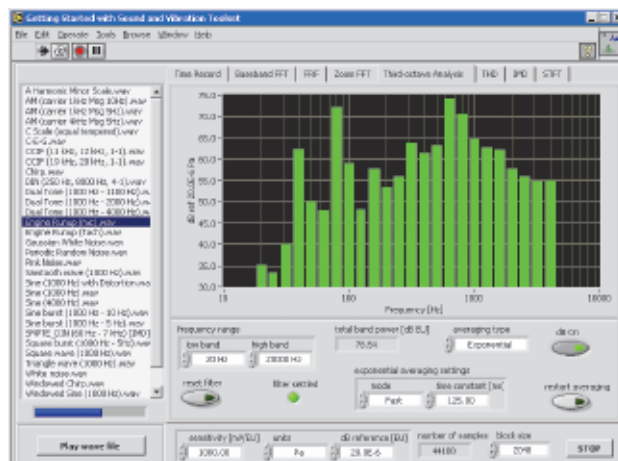

Figure 1. Sound and Vibration Toolkit

## NI LabVIEW Signal Processing Toolkit

This toolkit is a suite of software tools, example programs, and utilities for time-frequency analysis and digital filter design. The toolkit includes:

- Wavelet and filter-bank design
- Digital filter design of FIR and IIR filters
- Joint time-frequency analysis (JTFA) with the Gabor spectrograph
- High-frequency resolution model-based spectral estimation for small datasets

# S Series Multifunction DAQ 12 or 16-Bit, 1 to 10 MS/s, 4 Analog Inputs

## NI Spectral Measurements Toolkit

This toolkit includes all of the analysis and presentation tools to convert your S Series device into a full-featured spectrum analyzer. The toolkit includes:

- Measurements such as in-band power and adjacent-channel power
- 3D spectrogram
- Analog modulation and demodulation
- I-Q data for digital demodulation
- Highly optimized FFT processing

## High-Performance Data Throughput

Using NI-DAQmx driver software and S Series, you can take full advantage of your PC's throughput potential, which is useful in many applications including transient recording.

## Flexible Data Transfer

With NI-DAQmx, you can choose where to accumulate data – on the onboard memory, PC RAM memory, or PC hard drive memory. Thus, you can balance your PC application requirements and stream-to-disk/memory capabilities. In any case, NI-DAQmx optimizes data transfers by using DMA (direct memory access) and transferring large chunks of data, while ensuring no data loss. You can also choose the format of your data, further optimizing throughput. Choices include raw (binary), scaled, or the high-level waveform data type. Using these techniques, you can achieve rates of more than 40 MS/s sustained over the PCI/PXI bus to hard drive (depending on the PC).

## Data Compaction

With the release of NI-DAQmx 7.4 or later, data compaction is available for stream-to-disk applications. The NI-DAQmx compaction feature strips unused or unwanted bits of data from each sample taken from your S Series device before it is permanently recorded to hard disk. This is helpful because hard drives are typically the throughput bottleneck compared to the PCI/PXI bus and PC RAM memory read/write speed. Using data compression, users with standard hard drives can see up to 20 percent higher throughput when streaming-to-disk.

## Signal Conditioning

With the release of NI-DAQmx 7.4 or later, all S Series devices are compatible with parallel-mode SCXI modules.

Model	Description	Channels
SCXI-1520	Universal Strain Gage Input	8
SCXI-1125	Isolation Amplifier	8
SCXI-1141/2/3	8-Pole Lowpass Filters	8

Table 3. Most Popular Parallel-Mode SCXI Modules

SCXI is limited to 100 kS/s for 16-bit accuracy and 333 kS/s for 12-bit accuracy when used in multiplexed mode. However, in parallel mode, the sample rate is limited by the maximum scan rate of the data acquisition device. When SCXI is used in parallel mode with S Series, all channels are simultaneously sampled and the sampling rate is limited by the S Series device, from 250 kS/s per channel to 10 MS/s per channel.

## Measurement Services Software

National Instruments measurement services software, built around NI-DAQmx driver software, includes intuitive application programming interfaces, configuration tools, I/O assistants, and other tools designed to reduce system setup, configuration, and development time.

**Automatic Code Generation** – DAQ Assistant is an interactive guide that helps you navigate through configuring, testing, and programming measurement tasks and automatically generates the necessary code for LabVIEW, LabWindows/CVI, or Measurement Studio.

**Cleaner Code Development** – Basic and advanced software functions have been combined into one easy-to-use yet powerful set to help you build cleaner code and move from basic to advanced applications without replacing functions.

**High-Performance Driver Engine** – NI-DAQmx delivers maximum I/O system throughput with a multithreaded driver.

**Test Panels** – With the Measurement & Automation Explorer configuration utility, you can test all of your module functionality before you begin development.

**Scaled Channels** – Easily scale your voltage data into the proper engineering units using the NI-DAQmx Measurement Ready virtual channels by choosing from a list of common sensors and signals or creating your own custom scale.

**Data-Logging Software** – VI Logger Lite is configuration-based software designed specifically for data logging. Features include easy logging and viewing of data, data extraction to Microsoft Excel, and code generation in LabVIEW.

**LabVIEW Integration** – All NI-DAQmx functions create the waveform data type, which carries acquired data and timing information directly into more than 400 LabVIEW built-in analysis routines for display of results in engineering units on a graph.

## NI-DAQmx Base Driver

NI-DAQmx Base (available at [ni.com/downloads](http://ni.com/downloads)) offers Mac OS X and Linux users a programming interface similar to NI-DAQmx. It includes ready-to-use LabVIEW VIs and C function features similar to those included in NI-DAQmx driver software.

# S Series Multifunction DAQ 12 or 16-Bit, 1 to 10 MS/s, 4 Analog Inputs

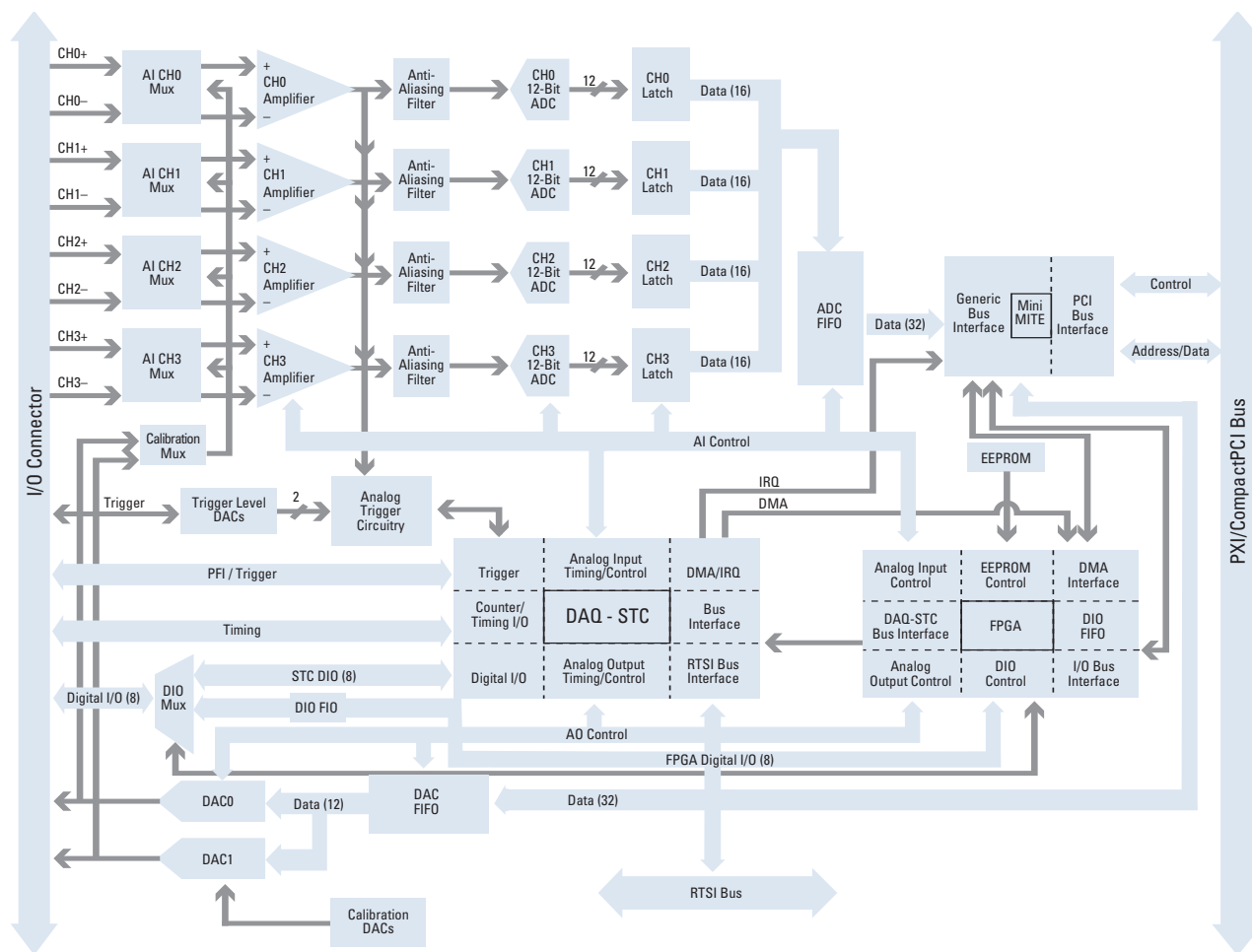

Figure 2. NI 6120 and NI 6115 Hardware Block Diagram

# S Series Multifunction DAQ 12 or 16-Bit, 1 to 10 MS/s, 4 Analog Inputs

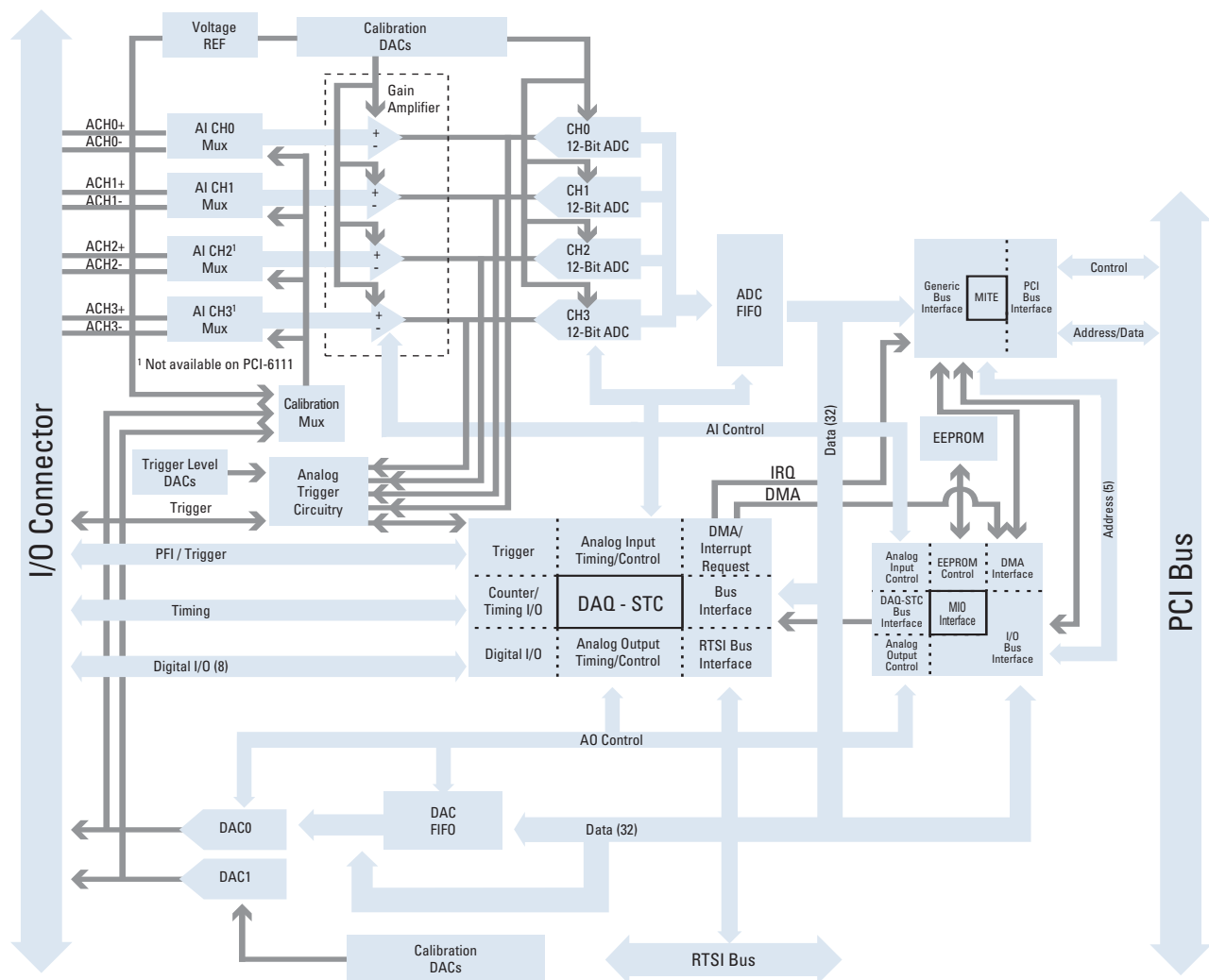

Figure 3. NI 6110 and 6111 Hardware Block Diagram

## Ordering Information

### PCI

NI PCI-6120 .....	778397-01
NI PCI-6115 with 32 MS .....	778534-01
64 MS .....	778554-01
NI PCI-6111 .....	777530-01
NI PCI-6110 .....	777475-01

### PXI

NI PXI-6115 with 32 MS .....	778194-01
64 MS .....	778204-01
NI PXI-6120 .....	778396-01

Includes data acquisition driver software.

### BUY NOW!

For complete product specifications, pricing, and accessory information, call (800) 813 3693 (U.S. only) or go to [ni.com/dataacquisition](http://ni.com/dataacquisition).

# S Series Multifunction DAQ 12 or 16-Bit, 1 to 10 MS/s, 4 Analog Inputs

## Specifications

These specifications are typical for 25 °C unless otherwise noted.

### Analog Input

#### Input Characteristics

Number of channels	
NI 6110, NI 6115, NI 6120 .....	4 pseudodifferential
NI 6111 .....	2 pseudodifferential
ADC resolution	
NI 6110, NI 6111, NI 6115 .....	12 bits, 1 in 4,096
NI 6120 .....	16 bits, 1 in 65,536
ADC pipeline	
NI-6110, NI 6111 .....	3
NI 6115 .....	4
NI 6120 .....	0
Maximum sampling rate	
NI 6110, NI 6111 .....	5 MS/s
NI 6115 .....	10 MS/s
NI 6120 .....	1 MS/s <sup>1</sup>
Minimum sampling rate	
NI 6110, NI 6111 .....	1 kS/s
NI 6115 .....	20 kS/s
NI 6120 .....	No minimum
Input signal ranges	
(selectable by channel).....	±42, ±20, ±10, ±5, ±2, ±1, ±0.5, ±0.2 V
Input coupling.....	AC or DC
Max working voltage for all analog input channels	
Overvoltage protection	
(ACH+, ACH-) .....	±42 V
Input FIFO buffer	
NI 6110, NI 6111 .....	8,192 samples
NI 6115, NI 6120 .....	16 Msamples or 32 Msamples
Data transfers .....	DMA (scatter-gather), interrupts, programmed I/O
Analog filter type	
NI 6115 .....	3-pole Bessel
NI 6120 .....	5-pole Bessel
Analog filter frequency (-3 dB)	
NI 6115 .....	50 and 500 kHz
NI 6120 .....	100 kHz

<sup>1</sup>900 kS/s with NI-DAQmx, 1 MS/s with additional download. Special conditions apply.

### Analog Output

#### Output Characteristics

Number of channels.....		2 voltage
Resolution		
NI 6110, NI 6111, NI 6120 .....	16 bits, 1 in 65,536	
NI 6115 .....	12 bits, 1 in 4,096	
Max update rate		
1 channel .....	4 MS/s	
2 channel .....	2.5 MS/s	
Output FIFO buffer size		
NI 6110, NI 6111 .....	2,048 samples	
NI 6115, NI 6120 .....	16 or 32 Msamples	
Data transfers .....	DMA (scatter-gather), interrupts, programmed I/O	

#### Voltage Output

Ranges .....	±10 V
Output coupling.....	DC

### Digital I/O

Number of channels.....		8 input/output
Compatibility .....		TTL/CMOS
Power-on state .....		Input (high-impedance)
Data transfers		
NI 6110, NI 6111 .....	Programmed I/O	
NI 6115, NI 6120 .....	DMA (scatter-gather), interrupts, programmed I/O	
Transfer rate		
NI 6115, NI 6120 .....	10 Mbytes/s	
Input buffer size		
NI 6115, NI 6120 .....	2,048 bytes	
Output buffer size		
NI 6115, NI 6120 .....	2,048 bytes	

### Timing I/O

Number of channels	
Up/down counter/timers.....	2
Frequency scaler.....	1
Resolution	
Up/down counter/timers.....	24 bits
Frequency scaler.....	4 bits
Compatibility .....	TTL/CMOS
Base clocks available	
Up/down counter/timers.....	20 MHz, 100 kHz
Frequency scaler.....	10 MHz, 100 kHz
Base clock accuracy.....	±0.01%
Maximum source frequency	
Up/down counter/timers.....	20 MHz
Minimum source pulse duration.....	10 ns, edge-detect mode
Minimum gate pulse duration.....	10 ns, edge-detect mode
Data transfers .....	DMA (scatter-gather), interrupts, programmed I/O

### Triggers

#### Analog Trigger

Purpose	
Analog input .....	Start and stop trigger, gate, clock
Analog output .....	Start trigger, gate, clock
General-purpose counter/timers .....	Source, gate
Source.....	All analog input channels, PFI0/TRIG1
Level	
Internal source, ACH<0..3> .....	±Full-scale
External source, PFI0/TRIG1 .....	±10 V
Slope.....	Positive or negative; software-selectable
Resolution	
NI 6110, NI 6111, NI 6115 .....	8 bits, 1 in 256
NI 6120 .....	12 bits, 1 in 4,096
Hysteresis .....	Programmable
Bandwidth (-3 dB)	
Internal source, ACH<0..3> .....	5 MHz
External source, PFI0/TRIG1 .....	5 MHz

#### Digital Trigger

Purpose	
Analog input .....	Start and stop trigger, gate, clock
Analog output .....	Start trigger, gate, clock
General-purpose counter/timers .....	Source, gate
External Sources .....	PFI<0..9>, RTSI<0..6>
Compatibility .....	5 V/TTL
Response .....	Rising or falling edge
Pulse width.....	10 ns minimum

#### PXI Trigger Bus (PXI only)

Trigger lines.....	7
--------------------	---

#### RTSI Bus (PCI only)

Trigger lines.....	7
--------------------	---

### Bus Interface

PXI or PCI.....	Master, slave
-----------------	---------------

### Physical

Dimensions (not including connectors)	
PCI .....	31.2 by 10.6 cm (12.3 by 4.2 in.)
PXI .....	16 by 10 cm (6.3 by 3.9 in.)
I/O connector.....	68-pin male SCSI II type

# S Series Multifunction DAQ Cables and Accessories



SH68-68-EP Shielded Cable



R6868 Ribbon Cable



BNC-2110 I/O Connector Block



TB-2705 Terminal Block



SCB-68 Shielded I/O Connector Block



CB-68LP and CB-68LPR I/O Connector Blocks

## Recommended Configurations

I/O Configuration	Accessory	Cable
BNC shielded	BNC-2110 (777643-01)	SH68-68-EP (184749-01)
Front-mount shielded screw terminals (PXI only)	TB-2705 (778241-01)	–
Noise-rejecting shielded screw terminals	SCB-68 (776844-01)	SH68-68-EP (184749-01)
Low-cost unshielded screw terminals	CB-68LPR (777145-02)	R6868 (777643-01)

### SH68-68-EP Noise-Rejecting Shielded Cable

The SH68-68-EP is a shielded 68-conductor cable terminated with two 68-pin female 0.050 series D-type connectors. It features individually shielded analog twisted pairs for reduced cross-talk with high-speed devices.

1 m .....	184749-01
2 m .....	184749-02

### R6868 Low-Cost, Ribbon Cable

The R6868 is a 68-conductor flat ribbon cable terminated with two 68-pin female 0.050 series D-type connectors.

1 m .....	182482-01
-----------	-----------

### BNC-2110 Noise-Rejecting BNC I/O Connector Block

The BNC-2110 is a shielded connector block with signal-labeled BNC connectors for easy connectivity of your analog input, digital I/O, and counter/timer signals.

BNC-2110 .....	777643-01
Dimensions – 20.3 by 11.2 by 5.5 cm (8.0 by 4.4 by 2.2 in.)	

### TB-2705 Noise-Rejecting Front-Mount I/O Connector Block

The TB-2705 is a screw terminal block for your PXI DAQ devices. It latches to the front of your PXI modules with locking screws and provides strain relief and easy access to your analog, digital, trigger, and counter/timer signals through screw terminals.

TB-2705 .....	778241-01
Dimensions – 8.43 by 10.41 by 2.03 cm (3.32 by 4.1 by 0.8 in.)	

### SCB-68 Noise-Rejecting Shielded I/O Connector Block

The SCB-68 is a shielded I/O connector block for rugged, very-low-noise signal termination for connecting 68-pin DAQ devices. Silk-screened component locations provide an easy addition of simple signal-conditioning circuitry for your analog input channels. It also includes a general-purpose breadboard area as well as an IC temperature sensor for cold-junction compensation in temperature measurements.

SCB-68 .....	776844-01
Dimensions – 19.5 by 15.2 by 4.5 cm (7.7 by 6.0 by 1.8 in.)	

### CB-68LP and CB-68LPR Low-Cost I/O Connector Blocks

The CB-68 and CB-68LP are low-cost termination accessories with 68 screw terminals for easy connector of field I/O signals to 68-pin DAQ devices. The connector blocks include standoffs for use on a desktop or for mounting in a custom panel. The CB-68LP has a vertical-mounted 68-pin connector. The CB-68-LPR has a right-angle mounted connector, and it is used with the CA-1000.

CB-68LP .....	777145-01
Dimensions – 14.35 by 10.74 cm (5.65 by 4.23 in.)	
CB-68LPR .....	777145-02
Dimensions – 7.62 by 16.19 cm (3.00 by 6.36 in.)	

# NI Services and Support

NI has the services and support to meet your needs around the globe and through the application life cycle – from planning and development through deployment and ongoing maintenance. We offer services and service levels to meet customer requirements in research, design, validation, and manufacturing. Visit [ni.com/services](http://ni.com/services).

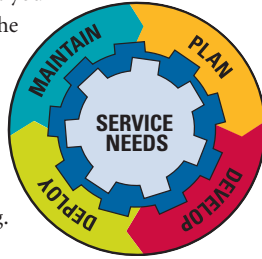

## Training and Certification

NI training is the fastest, most certain route to productivity with our products. NI training can shorten your learning curve, save development time, and reduce maintenance costs over the application life cycle. We schedule instructor-led courses in cities worldwide, or we can hold a course at your facility. We also offer a professional certification program that identifies individuals who have high levels of skill and knowledge on using NI products. Visit [ni.com/training](http://ni.com/training).

## Professional Services

Our Professional Services Team is comprised of NI applications engineers, NI Consulting Services, and a worldwide National Instruments Alliance Partner program of more than 600 independent consultants and integrators. Services range from start-up assistance to turnkey system integration. Visit [ni.com/alliance](http://ni.com/alliance).



## OEM Support

We offer design-in consulting and product integration assistance if you want to use our products for OEM applications. For information about special pricing and services for OEM customers, visit [ni.com/oem](http://ni.com/oem).

## Local Sales and Technical Support

In offices worldwide, our staff is local to the country, giving you access to engineers who speak your language. NI delivers industry-leading technical support through online knowledge bases, our applications engineers, and access to 14,000 measurement and automation professionals within NI Developer Exchange forums. Find immediate answers to your questions at [ni.com/support](http://ni.com/support).

We also offer service programs that provide automatic upgrades to your application development environment and higher levels of technical support. Visit [ni.com/ssp](http://ni.com/ssp).

## Hardware Services

### NI Factory Installation Services

NI Factory Installation Services (FIS) is the fastest and easiest way to use your PXI or PXI/SCXI combination systems right out of the box. Trained NI technicians install the software and hardware and configure the system to your specifications. NI extends the standard warranty by one year on hardware components (controllers, chassis, modules) purchased with FIS. To use FIS, simply configure your system online with [ni.com/pxiadvisor](http://ni.com/pxiadvisor).

### Calibration Services

NI recognizes the need to maintain properly calibrated devices for high-accuracy measurements. We provide manual calibration procedures, services to recalibrate your products, and automated calibration software specifically designed for use by metrology laboratories. Visit [ni.com/calibration](http://ni.com/calibration).

### Repair and Extended Warranty

NI provides complete repair services for our products. Express repair and advance replacement services are also available. We offer extended warranties to help you meet project life-cycle requirements. Visit [ni.com/services](http://ni.com/services).



[ni.com](http://ni.com) • (800) 813 3693

National Instruments • [info@ni.com](mailto:info@ni.com)

© 2005 National Instruments Corporation. All rights reserved. CVI, DAQ-STC, LabVIEW, Measurement Studio, MITE, National Instruments, National Instruments Alliance Partner, NI, ni.com, NI-DAQ, RTSI, SCXI, and SignalExpress are trademarks of National Instruments. Other product and company names listed are trademarks or trade names of their respective companies. A National Instruments Alliance Partner is a business entity independent from NI and has no agency, partnership, or joint-venture relationship with NI.