

# Agilent T-1<sup>3</sup>/<sub>4</sub> Super Ultra-Bright LED Lamps Data Sheet

HLMP-C115, HLMP-C117, HLMP-C123, HLMP-C215, HLMP-C223,  
HLMP-C315, HLMP-C323, HLMP-C415, HLMP-C423, HLMP-C515,  
HLMP-C523, HLMP-C615, HLMP-C623

## Description

These non-diffused lamps are designed to produce a bright light source and smooth radiation pattern. A slight tint is added to the lens for easy color identification. This lamp has been designed with a

20 mil lead frame, enhanced flange, and tight meniscus controls, making it compatible with radial lead automated insertion equipment.

## Features

- Very high intensity
  - Exceptional uniformity
  - Microtint lens for color identification
  - Consistent viewability
- All colors:
- AlGaAs Red
  - High Efficiency Red
  - Yellow
  - Orange
  - Green
  - Emerald Green
- 15° and 25° family
  - Tape and reel options available
  - Binned for color and intensity

## Applications

- Ideal for backlighting front panels\*
- Used for lighting switches
- Adapted for indoor and outdoor signs



Agilent Technologies

## Selection Guide

Color	2θ <sup>1/2</sup> [1]	Standoff Leads	Part Number HLMP-	Luminous Intensity Iv (mcd)		
				Min.	Max.	
DH AS AlGaAs	15	No	C115	290.0	–	
			C115-000xx	290.0	–	
			C115-OP0xx	290.0	1000.0	
	25	Yes	C117-OP0xx	290.0	1000.0	
			No	C123	90.2	–
				C123-L00xx	90.2	–
Red	15	No	C215	138.0	–	
			C215-M00xx	138.0	–	
			C215-MN0xx	138.0	400.0	
	25	No	C223	90.2	–	
			C223-L00xx	90.2	–	
			C223-MN0xx	138.0	400.0	
Yellow	15	No	C315	147.0	–	
			C315-L00xx	147.0	–	
			C315-LM0xx	147.0	424.0	
	25	No	C323	96.2	–	
			C323-K00xx	96.2	–	
			C323-KL0xx	96.2	294.0	
Orange	15	No	C415	138.0	–	
			C415-M00xx	138.0	–	
			C415-M0D0xx	138.0	–	
	25	No	C415-MN0xx	138.0	400.0	
			C423	90.2	–	
			C423-L00xx	90.2	–	
25	No	C423-LM0xx	90.2	276.0		
		15	No	C515	170.0	–
				C515-L00xx	170.0	–
C515-LM0xx	170.0			490.0		
Green	25	No	C523	69.8	–	
			C523-J00xx	69.8	–	
			C523-KL0xx	111.7	340.0	
			Emerald Green	15	No	C615
C615-G00xx	17.0	–				
25	No	C623				6.7
		C623-E00xx	6.7	–		

## Part Numbering System

HLMP - C x xx - x x x xx

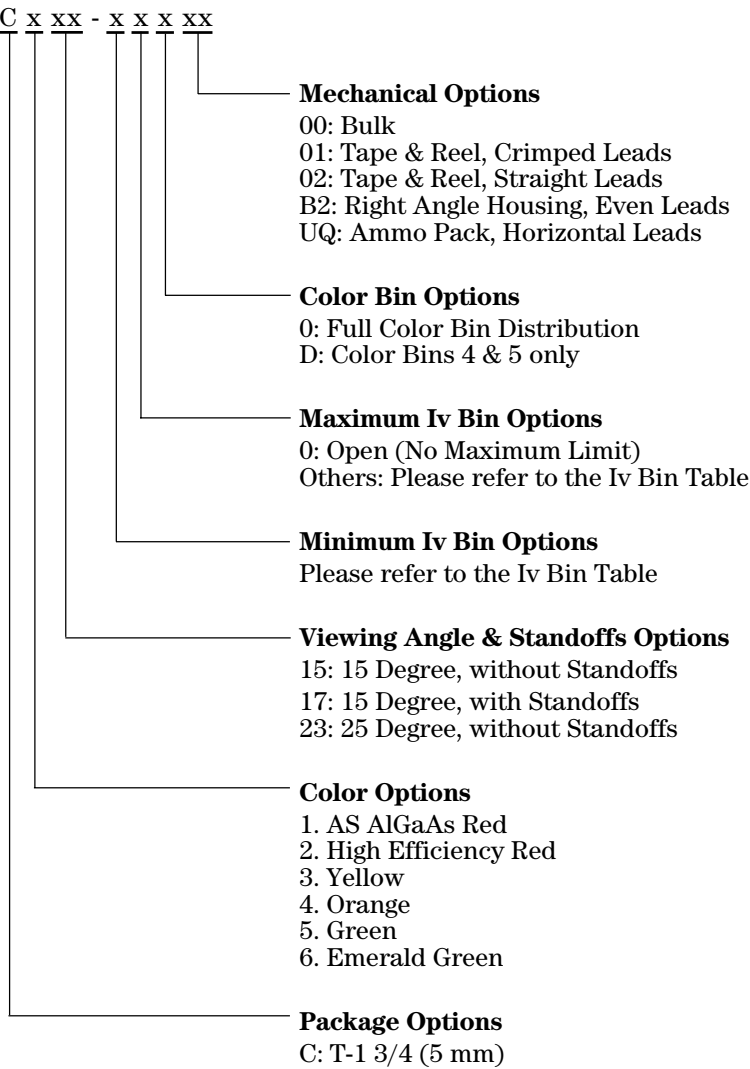

## Package Dimensions

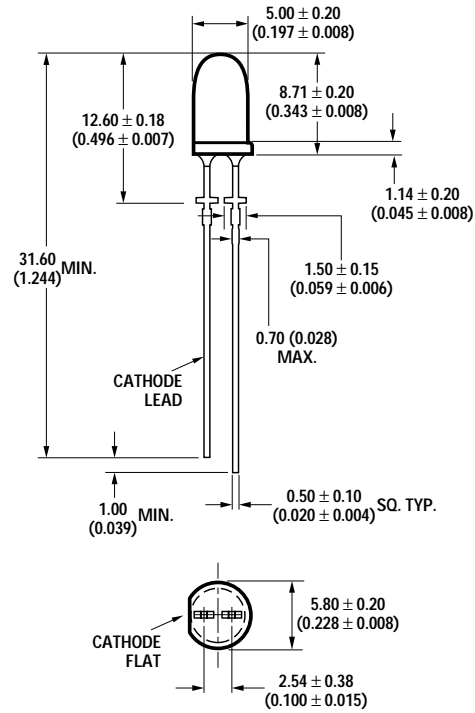
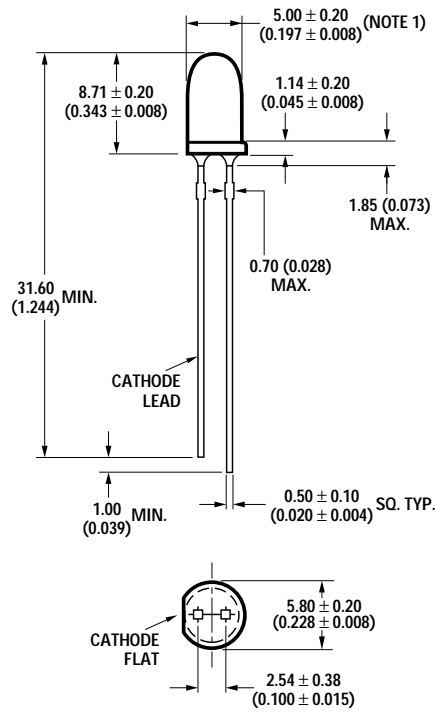

### NOTES:

1. ALL DIMENSIONS ARE IN MILLIMETERS (INCHES).
2. LEADS ARE MILD STEEL, SOLDER DIPPED.
3. AN EPOXY MENISCUS MAY EXTEND ABOUT 0.5 mm (0.020 in.) DOWN THE LEADS.

HLMP-Cx15 and HLMP-Cx23

HLMP-Cx17

## Absolute Maximum Ratings at $T_A = 25^\circ\text{C}$

Parameter	DH AS	High		High	Units
	AlGaAs	Efficiency	Yellow	Performance	
	Red	Red and		Green and	
		Orange		Emerald Green	
DC Forward Current <sup>[1]</sup>	30	30	20	30	mA
Transient Forward Current <sup>[2]</sup> (10 $\mu\text{sec}$ Pulse)	500	500	500	500	mA
Reverse Voltage ( $I_r = 100 \mu\text{A}$ )	5	5	5	5	V
LED Junction Temperature	110	110	110	110	$^\circ\text{C}$
Operating Temperature Range	-20 to +100	-55 to +100		-20 to +100	$^\circ\text{C}$
Storage Temperature Range		-55 to +100			$^\circ\text{C}$

### Notes:

1. See Figure 5 for maximum current derating vs. ambient temperature.
2. The transient current is the maximum nonrecurring peak current the device can withstand without damaging the LED die and wire bond.

**Electrical Characteristics at T<sub>A</sub> = 25°C**

Part Number	Forward Voltage V <sub>f</sub> (Volts) @ I <sub>f</sub> = 20 mA		Reverse Breakdown V <sub>r</sub> (Volts) @ I <sub>r</sub> = 100 μA	Capacitance C (pF) V <sub>f</sub> = 0 f = 1 MHz	Thermal Resistance R <sub>θJ-PIN</sub> (°C/W)	Speed of Response τ <sub>s</sub> (ns) Time Constant e <sup>-1/τs</sup>
	Typ.	Max.	Min.	Typ.		Typ.
HLMP-C115 HLMP-C117 HLMP-C123	1.8	2.2	5	30	210	30
HLMP-C215 HLMP-C223	1.9	2.6	5	11	210	90
HLMP-C315 HLMP-C323	2.1	2.6	5	15	210	90
HLMP-C415 HLMP-C423	1.9	2.6	5	4	210	280
HLMP-C515 HLMP-C523	2.2	3.0	5	18	210	260
HLMP-C615 HLMP-C623	2.2	3.0	5	18	210	260

**Optical Characteristics at T<sub>A</sub> = 25°C**

Part Number	Luminous Intensity I <sub>v</sub> (mcd) @ 20 mA <sup>[1]</sup>		Peak Wavelength λ <sub>peak</sub> (nm)	Color, Dominant Wavelength λ <sub>d</sub> <sup>[2]</sup> (nm)	Viewing Angle 2θ <sub>1/2</sub> (Degrees) <sup>[3]</sup>	Luminous Efficacy η <sub>v</sub> (lm/w)
	Min.	Typ.	Typ.	Typ.	Typ.	
HLMP-C115 HLMP-C117	290	600	645	637	11	80
HLMP-C123	90	200			26	
HLMP-C215	138	300	635	626	17	145
	90	170			23	
HLMP-C315	146	300	583	585	17	500
	96	170			25	
HLMP-C415	138	300	600	602	17	380
	90	170			23	
HLMP-C515	170	300	568	570	20	595
	69	170			28	
HLMP-C615	17	45	558	560	20	656
	6	27			28	

**Notes:**

1. The luminous intensity, I<sub>v</sub>, is measured at the mechanical axis of the lamp package. The actual peak of the spatial radiation pattern may not be aligned with this axis.
2. The dominant wavelength, λ<sub>d</sub>, is derived from the CIE Chromaticity Diagram and represents the color of the device.
3. 2θ<sub>1/2</sub> is the off-axis angle where the luminous intensity is 1/2 the on-axis intensity.

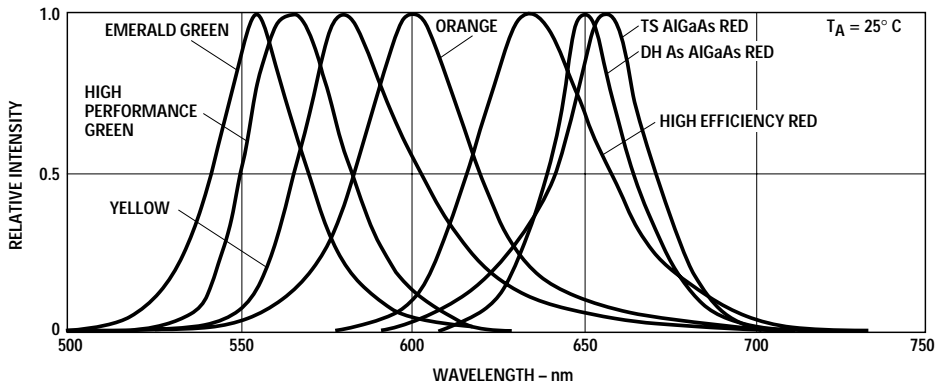

Figure 1. Relative intensity vs. wavelength.

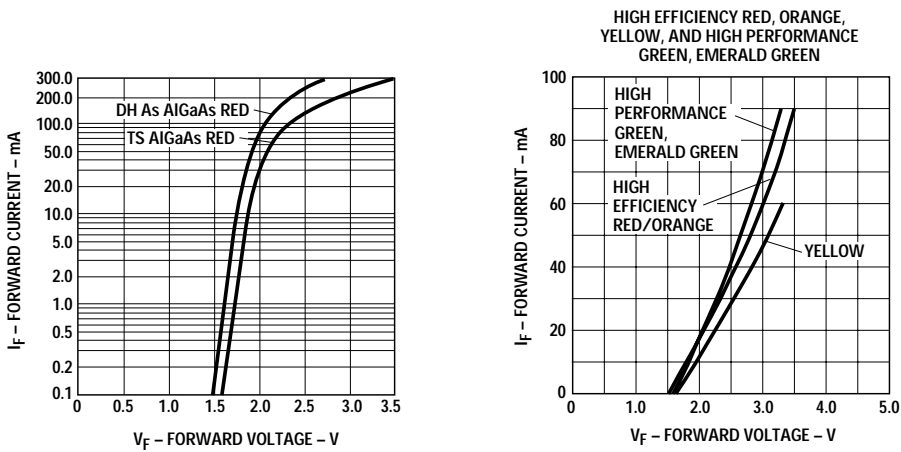

Figure 2. Forward current vs. forward voltage (non-resistor lamp).

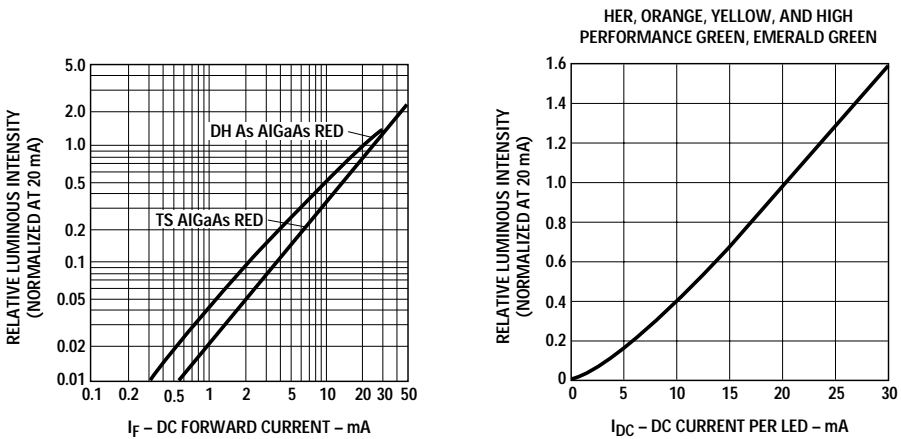

Figure 3. Relative luminous intensity vs. forward current.

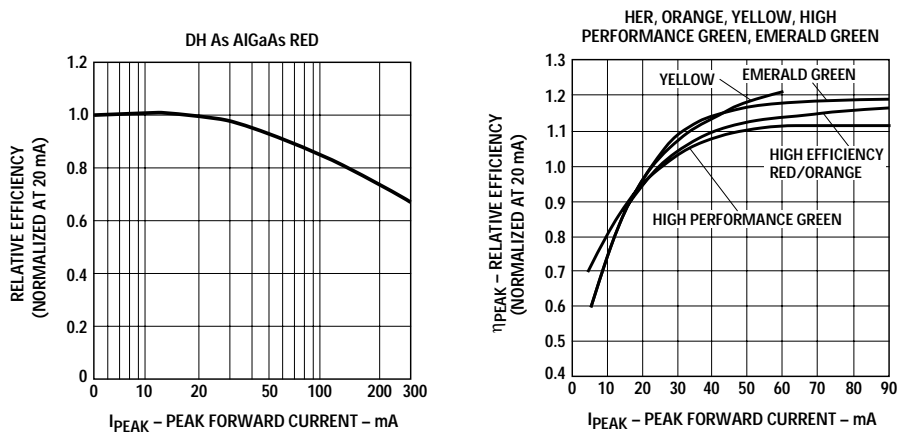

Figure 4. Relative efficiency (luminous intensity per unit current) vs. peak current.

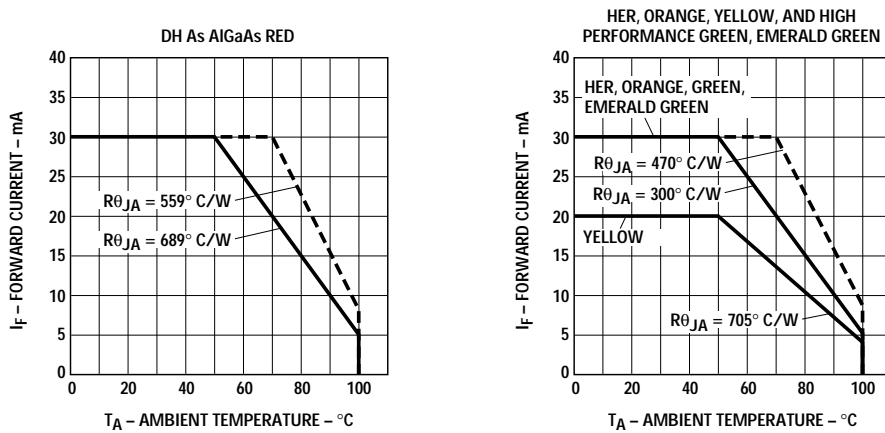

Figure 5. Maximum forward dc current vs. ambient temperature. Derating based on T<sub>j</sub>MAX = 110°C.

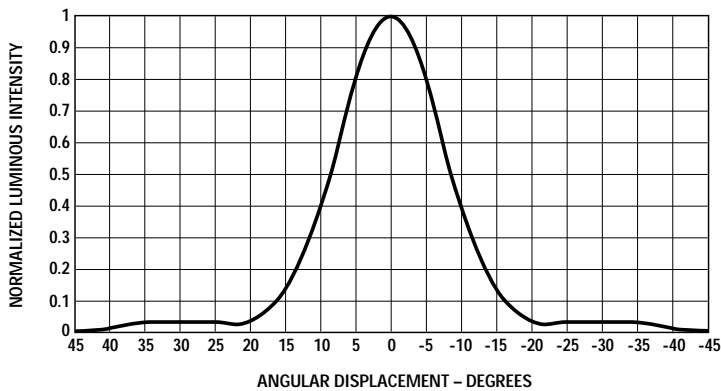

Figure 6. Relative luminous intensity vs. angular displacement. 15 degree family.

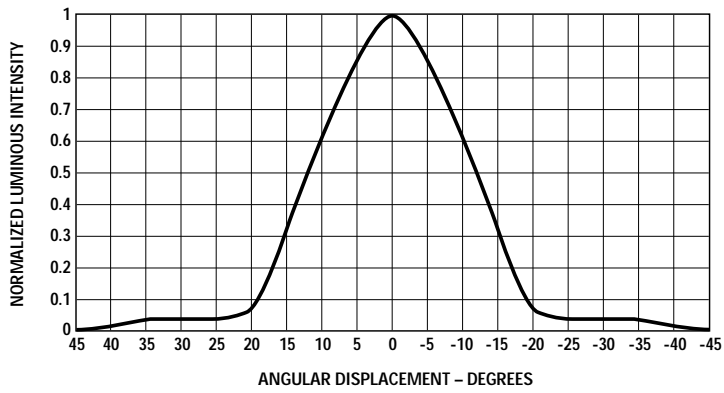

Figure 7. Relative luminous intensity vs. angular displacement. 25 degree family.

### Intensity Bin Limits

Color	Bin	Intensity Range (mcd)	
		Min.	Max.
Red/Orange	L	101.5	162.4
	M	162.4	234.6
	N	234.6	340.0
	O	340.0	540.0
	P	540.0	850.0
	Q	850.0	1200.0
	R	1200.0	1700.0
	S	1700.0	2400.0
	T	2400.0	3400.0
	U	3400.0	4900.0
	V	4900.0	7100.0
	W	7100.0	10200.0
	X	10200.0	14800.0
Yellow	Y	14800.0	21400.0
	Z	21400.0	30900.0
	L	173.2	250.0
	M	250.0	360.0
	N	360.0	510.0
	O	510.0	800.0
	P	800.0	1250.0
	Q	1250.0	1800.0
	R	1800.0	2900.0
	S	2900.0	4700.0
	T	4700.0	7200.0
U	7200.0	11700.0	
V	11700.0	18000.0	
W	18000.0	27000.0	



**Intensity Bin Limits, continued**

Color	Bin	Intensity Range (mcd)	
		Min.	Max.
Green/ Emerald Green	E	7.6	12.0
	F	12.0	19.1
	G	19.1	30.7
	H	30.7	49.1
	I	49.1	78.5
	J	78.5	125.7
	K	125.7	201.1
	L	201.1	289.0
	M	289.0	417.0
	N	417.0	680.0
	O	680.0	1100.0
	P	1100.0	1800.0
	Q	1800.0	2700.0
	R	2700.0	4300.0
	S	4300.0	6800.0
T	6800.0	10800.0	
U	10800.0	16000.0	
V	16000.0	25000.0	
W	25000.0	40000.0	

Maximum tolerance for each bin limit is  $\pm 18\%$ .

**Color Categories**

Color	Category #	Lambda (nm)	
		Min.	Max.
Green	6	561.5	564.5
	5	564.5	567.5
	4	567.5	570.5
	3	570.5	573.5
	2	573.5	576.5
Yellow	1	582.0	584.5
	3	584.5	587.0
	2	587.0	589.5
	4	589.5	592.0
	5	592.0	593.0
Orange	1	597.0	599.5
	2	599.5	602.0
	3	602.0	604.5
	4	604.5	607.5
	5	607.5	610.5
	6	610.5	613.5
	7	613.5	616.5
	8	616.5	619.5

Tolerance for each bin limit is  $\pm 0.5$  nm.

## Mechanical Option Matrix

Mechanical Option Code	Definition
00	Bulk Packaging, minimum increment 500 pcs/bag
01	Tape & Reel, crimped leads, minimum increment 1300 pcs/bag
02	Tape & Reel, straight leads, minimum increment 1300 pcs/bag
B2	Right Angle Housing, even leads, minimum increment 500 pcs/bag
UQ	Ammo Pack, horizontal leads, in 1K minimum increment

**Note:**

All categories are established for classification of products. Products may not be available in all categories. Please contact your local Agilent representative for further clarification/information.

## Precautions

### Lead Forming

- The leads of an LED lamp may be preformed or cut to length prior to insertion and soldering into PC board.
- If lead forming is required before soldering, care must be taken to avoid any excessive mechanical stress induced to LED package. Otherwise, cut the leads of LED to length after soldering process at room temperature. The solder joint formed will absorb the mechanical stress of the lead cutting from traveling to the LED chip die attach and wirebond.
- It is recommended that tooling made to precisely form and cut the leads to length rather than rely upon hand operation.

### Soldering Conditions

- Care must be taken during PCB assembly and soldering process to prevent damage to LED component.
- The closest LED is allowed to solder on board is 1.59 mm below the body (encapsulant epoxy) for those parts without standoff.
- Recommended soldering conditions:

	Wave Soldering	Manual Solder Dipping
Pre-heat Temperature	105 °C Max.	–
Pre-heat Time	30 sec Max.	–
Peak Temperature	250 °C Max.	260 °C Max.
Dwell Time	3 sec Max.	5 sec Max.

- Wave soldering parameter must be set and maintained according to recommended temperature and dwell time in the solder wave. Customer is advised to periodically check on the soldering profile to ensure the soldering profile used is always conforming to recommended soldering condition.
- If necessary, use fixture to hold the LED component in proper orientation with respect to the PCB during soldering process.
- Proper handling is imperative to avoid excessive thermal stresses to LED components when heated. Therefore, the soldered PCB must be allowed to cool to room temperature, 25°C, before handling.
- Special attention must be given to board fabrication, solder masking, surface plating and lead holes size and component orientation to assure solderability.
- Recommended PC board plated through hole sizes for LED component leads:

LED Component Lead Size	Diagonal	Plated Through Hole Diameter
0.457 x 0.457 mm (0.018 x 0.018 inch)	0.646 mm (0.025 inch)	0.976 to 1.078 mm (0.038 to 0.042 inch)
0.508 x 0.508 mm (0.020 x 0.020 inch)	0.718 mm (0.028 inch)	1.049 to 1.150 mm (0.041 to 0.045 inch)

**Note:** Refer to application note AN1027 for more information on soldering LED components.

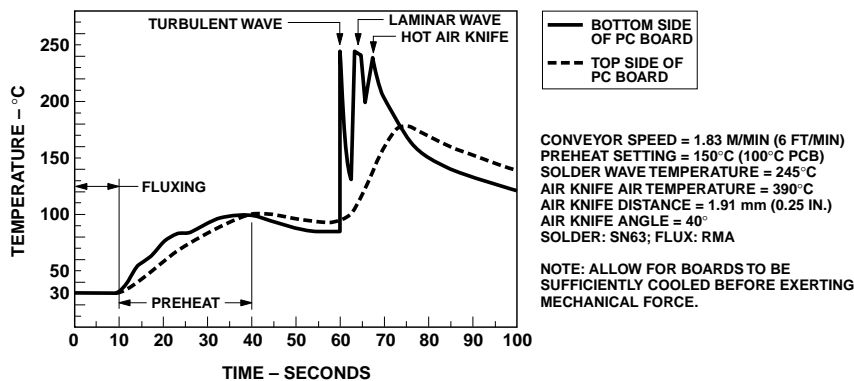

Figure 8. Recommended wave soldering profile.

**[www.agilent.com/semiconductors](http://www.agilent.com/semiconductors)**

For product information and a complete list of distributors, please go to our web site.

For technical assistance call:

Americas/Canada: +1 (800) 235-0312 or (916) 788-6763

Europe: +49 (0) 6441 92460

China: 10800 650 0017

Hong Kong: (+65) 6756 2394

India, Australia, New Zealand: (+65) 6755 1939

Japan: (+81 3) 3335-8152 (Domestic/International), or 0120-61-1280 (Domestic Only)

Korea: (+65) 6755 1989

Singapore, Malaysia, Vietnam, Thailand, Philippines, Indonesia: (+65) 6755 2044

Taiwan: (+65) 6755 1843

Data subject to change.

Copyright © 2004-2005 Agilent Technologies, Inc.

Obsoletes 5988-2149EN

November 12, 2005

5989-4251EN



**Agilent Technologies**