

FEATURES

- Operates from a Single 3.3V Supply
- Low Supply Current: $I_{CC} = 200\mu\text{A}$
- ESD Protection Over $\pm 10\text{kV}$
- Available in 16-Pin SOIC Narrow Package
- Uses Small Capacitors: $0.1\mu\text{F}$
- Operates to 120kbaud
- Output Overvoltage Does Not Force Current Back into Supplies
- EIA/TIA562 I/O Lines Can Be Forced to $\pm 25\text{V}$ Without Damage
- Pin Compatible with LT1181A

APPLICATIONS

- Notebook Computers
- Palmtop Computers

DESCRIPTION

The LTC1386 is an ultra-low power 2-driver/2-receiver EIA/TIA562 transceiver that operates from a single 3.3V supply. The charge pump requires only four space-saving $0.1\mu\text{F}$ capacitors. The supply current (I_{CC}) of the transceiver is only $200\mu\text{A}$ with driver outputs unloaded.

The LTC1386 is fully compliant with all data rate and overvoltage EIA/TIA562 specifications. The transceiver can operate up to 120kbaud with a 1000pF , $3\text{k}\Omega$ load. Both driver outputs and receiver inputs can be forced to $\pm 25\text{V}$ without damage and can survive multiple $\pm 10\text{kV}$ ESD strikes.

TYPICAL APPLICATION

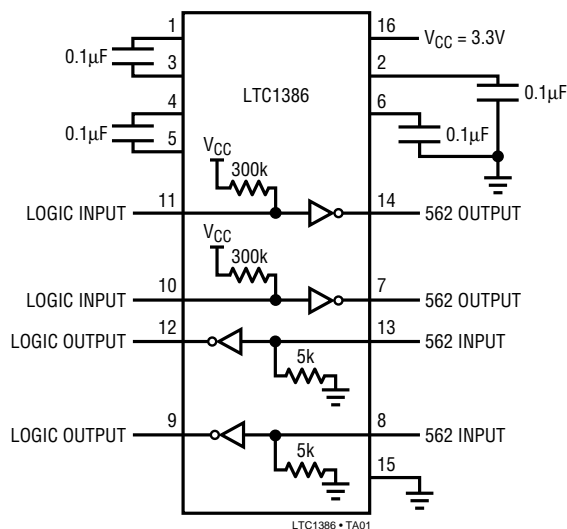

Quiescent Supply Current vs Temperature

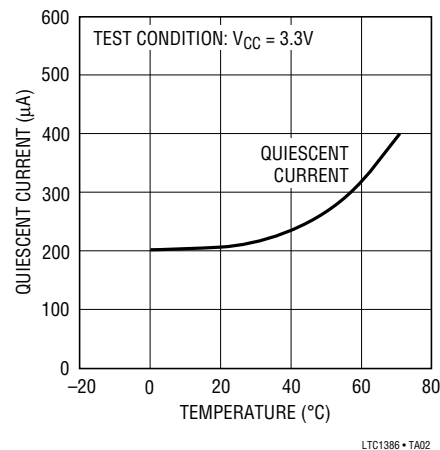

ABSOLUTE MAXIMUM RATINGS

Supply Voltage (V_{CC}) 5V

Input Voltage

Driver $-0.3V$ to $V_{CC} + 0.3V$

Receiver $-25V$ to $25V$

Digital Input $-0.3V$ to $V_{CC} + 0.3V$

Output Voltage

Driver $-25V$ to $25V$

Receiver $-0.3V$ to $V_{CC} + 0.3V$

Short-Circuit Duration

V^+ 30 sec

V^- 30 sec

Driver Output Indefinite

Receiver Output Indefinite

Operating Temperature Range $0^\circ C$ to $70^\circ C$

Storage Temperature Range $-65^\circ C$ to $150^\circ C$

Lead Temperature (Soldering, 10 sec) $300^\circ C$

PACKAGE/ORDER INFORMATION

TOP VIEW

N PACKAGE S PACKAGE
 16-LEAD PLASTIC DIP 16-LEAD NARROW PLASTIC SOIC

$T_{JMAX} = 125^\circ C, \theta_{JA} = 65^\circ C/W$ (N)
 $T_{JMAX} = 125^\circ C, \theta_{JA} = 95^\circ C/W$ (S)

ORDER PART NUMBER

LTC1386CN
LTC1386CS

Consult factory for Industrial and Military grade parts.

DC ELECTRICAL CHARACTERISTICS

$V_{CC} = 3.3V, C1 = C2 = C3 = C4 = 0.1\mu F$, unless otherwise noted.

PARAMETER	CONDITIONS	MIN	TYP	MAX	UNITS
Any Driver					
Output Voltage Swing	3k to GND	Positive	3.7	4.5	V
		Negative	-3.7	-4.5	V
Logic Input Voltage Level	Input Low Level ($V_{OUT} = \text{High}$)	0.8	1.4	0.8	V
	Input High Level ($V_{OUT} = \text{Low}$)	2.0	1.4		V
Logic Input Current	$V_{IN} = V_{CC}$			5	μA
	$V_{IN} = 0V$		-20	-40	μA
Output Short-Circuit Current	$V_{OUT} = 0V$		± 10		mA
Any Receiver					
Input Voltage Thresholds	Input Low Threshold	0.8	1.3		V
	Input High Threshold		1.7	2.4	V
Hysteresis		0.1	0.4	1	V
Input Resistance	$-10V \leq V_{IN} \leq 10V$	3	5	7	k Ω
Output Voltage	Output Low, $I_{OUT} = -1.6mA$ ($V_{CC} = 3.3V$)		0.2	0.4	V
	Output High, $I_{OUT} = 160\mu A$ ($V_{CC} = 3.3V$)	3.0	3.2		V
Output Short-Circuit Current	Sinking Current, $V_{OUT} = V_{CC}$	-5	-20		mA
	Sourcing Current, $V_{OUT} = GND$	2	7		mA
Power Supply Generator					
V^+ Output Voltage	$I_{OUT} = 0mA$		5.7		V
	$I_{OUT} = 5mA$		5.5		V
V^- Output Voltage	$I_{OUT} = 0mA$		-5.3		V
	$I_{OUT} = -5mA$		-5.0		V
Power Supply					
V_{CC} Supply Current	No Load (Note 2)		0.2	0.5	mA

AC CHARACTERISTICS $V_{CC} = 3.3V$, $C_1 = C_2 = C_3 = C_4 = 0.1\mu F$, unless otherwise noted.

PARAMETER	CONDITIONS	MIN	TYP	MAX	UNITS
Slew Rate	$R_L = 3k, C_L = 51pF$		8	30	$V/\mu s$
	$R_L = 3k, C_L = 1000pF$	3	5		$V/\mu s$
Driver Propagation Delay (TTL to EIA/TIA562)	t_{HLD} (Figure 1)	●	2	3.5	μs
	t_{LHD} (Figure 1)	●	2	3.5	μs
Receiver Propagation Delay (EIA/TIA562 to TTL)	t_{HLR} (Figure 2)	●	0.3	0.8	μs
	t_{LHR} (Figure 2)	●	0.3	0.8	μs

The ● denotes specifications which apply over the operating temperature range of $0^\circ C \leq T_A \leq 70^\circ C$.

Note 2: Supply current is measured with driver and receiver outputs unloaded.

Note 1: Absolute maximum ratings are those values beyond which the life of the device may be impaired.

TYPICAL PERFORMANCE CHARACTERISTICS

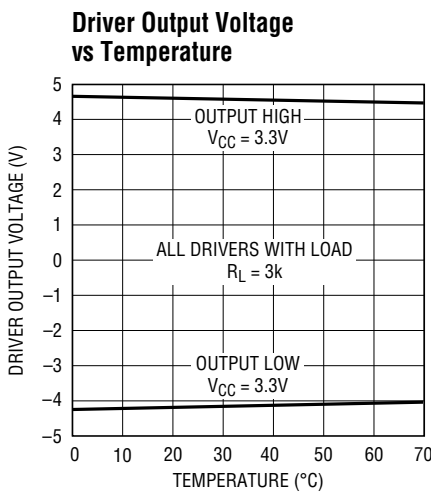

LTC1386 • TPC01

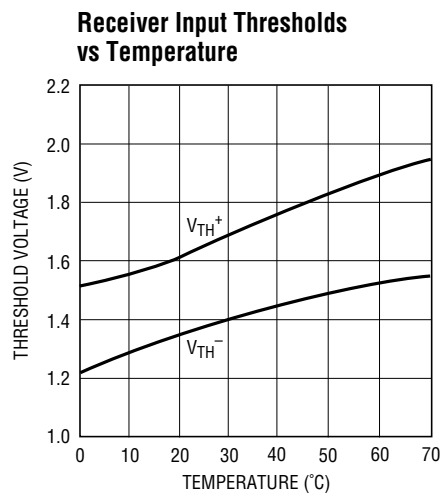

LTC1386 • TPC02

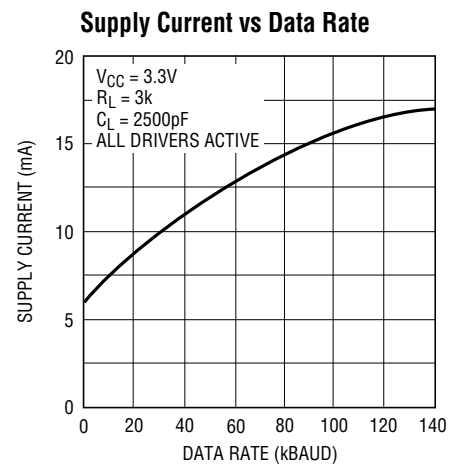

LTC1386 • TPC03

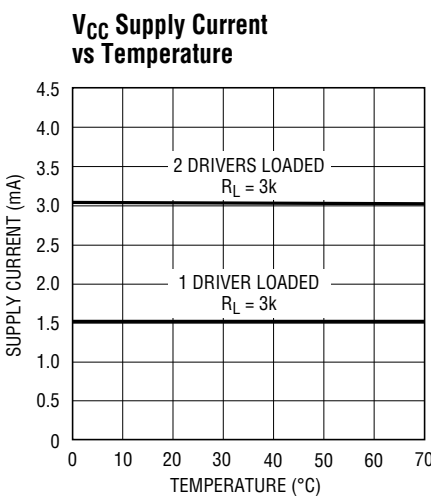

LTC1386 • TPC04

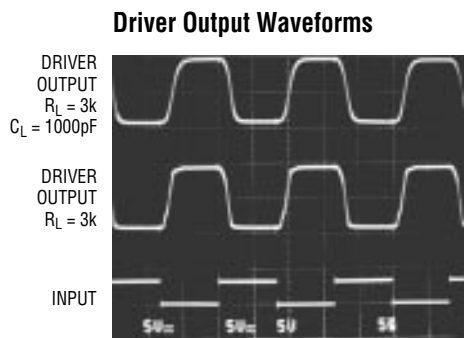

LTC1386 • TPC05

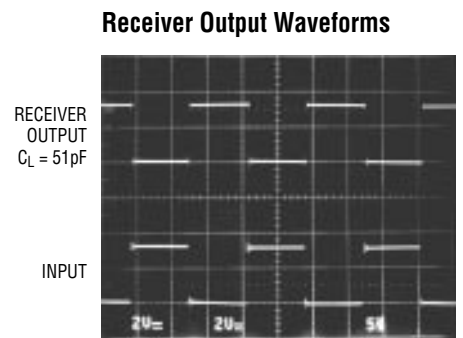

LTC1386 • TPC06

PIN FUNCTIONS

V_{CC}: 3.3V Input Supply Pin. This pin should be decoupled with a 0.1μF ceramic capacitor.

GND: Ground Pin.

V⁺: Positive Supply Output (EIA/TIA562 Drivers). $V^+ \cong 2V_{CC} - 1V$. This pin requires an external capacitor $C = 0.1\mu F$ for charge storage. The capacitor may be tied to ground or V_{CC} . With multiple devices, the V^+ and V^- pins may share a common capacitor. For large numbers of devices, increasing the size of the shared common storage capacitors is recommended to reduce ripple.

V⁻: Negative Supply Output (RS232 Drivers). $V^- \cong -(2V_{CC} - 1.3V)$. This pin requires an external capacitor $C = 0.1\mu F$ for charge storage.

C1⁺, C1⁻, C2⁺, C2⁻: Commutating Capacitor Inputs. These pins require two external capacitors $C = 0.1\mu F$: one from C1⁺ to C1⁻ and another from C2⁺ to C2⁻. To maintain

charge pump efficiency, the capacitor's effective series resistance should be less than 2Ω.

TR IN: EIA/TIA562 Driver Input Pins. Inputs are TTL/CMOS compatible. The inputs of unused drivers can be left unconnected since 300k input pull-up resistors to V_{CC} are included on chip.

TR OUT: Driver Outputs at EIA/TIA562 Voltage Levels. The driver outputs are protected against ESD to ±10kV for human body model discharges.

RX IN: Receiver Inputs. These pins can be forced to ±25V without damage. The receiver inputs are protected against ESD to ±10kV for human body model discharges. Each receiver provides 0.4V of hysteresis for noise immunity.

RX OUT: Receiver Outputs with TTL/CMOS Voltage Levels.

SWITCHING TIME WAVEFORMS

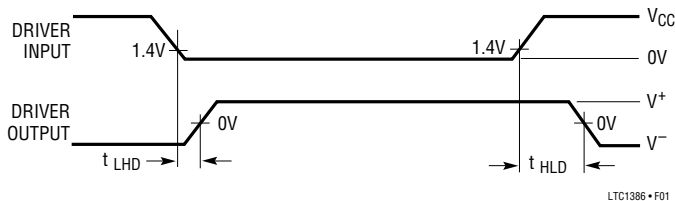

Figure 1. Driver Propagation Delay Timing

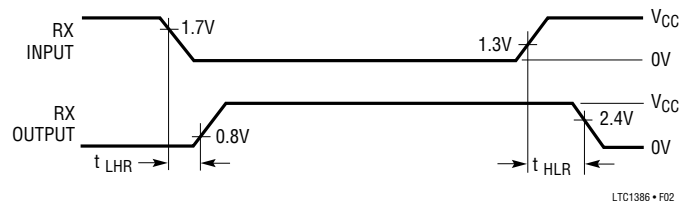
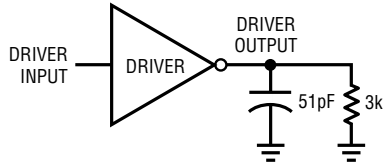

Figure 2. Receiver Propagation Delay Timing

TEST CIRCUITS

Driver Timing Test Load



LTC1386 • TA03

Receiver Timing Test Load

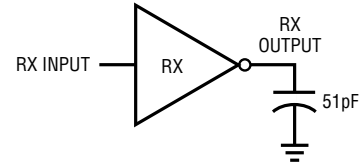

LTC1386 • TA04

ESD Test Circuit

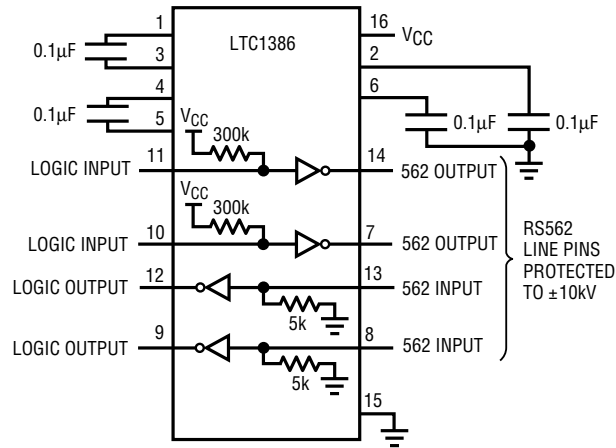

1386 TA05

TYPICAL APPLICATIONS

**Paralleling Power Supply Generator
with Common Storage Capacitors**

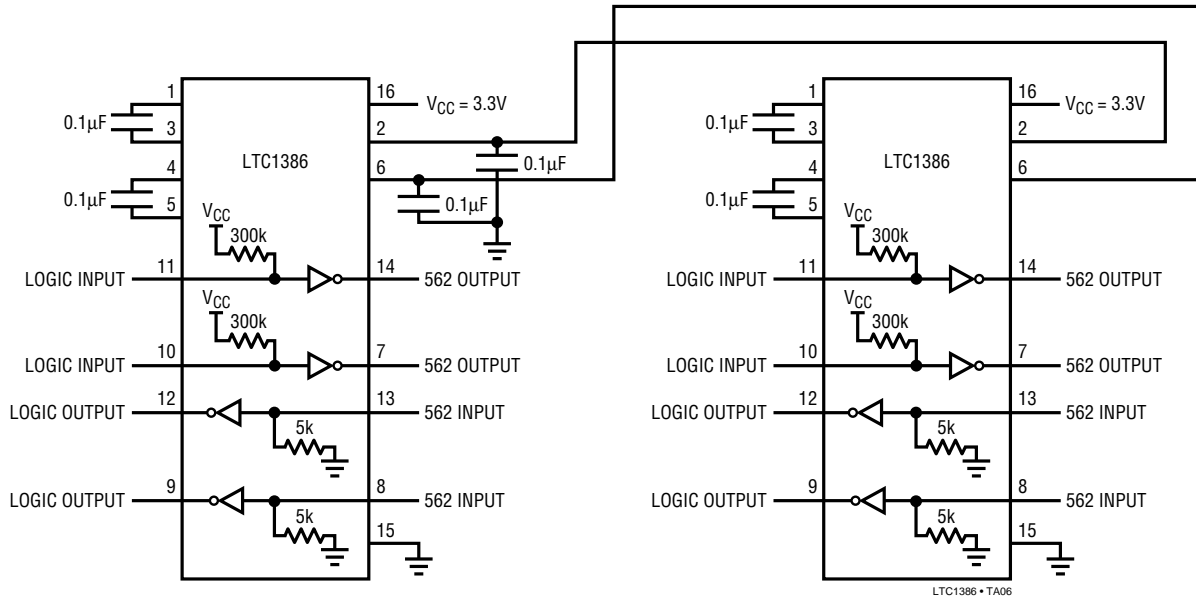

PACKAGE DESCRIPTION Dimensions in inches (millimeters) unless otherwise noted.

N Package
16-Lead Plastic DIP

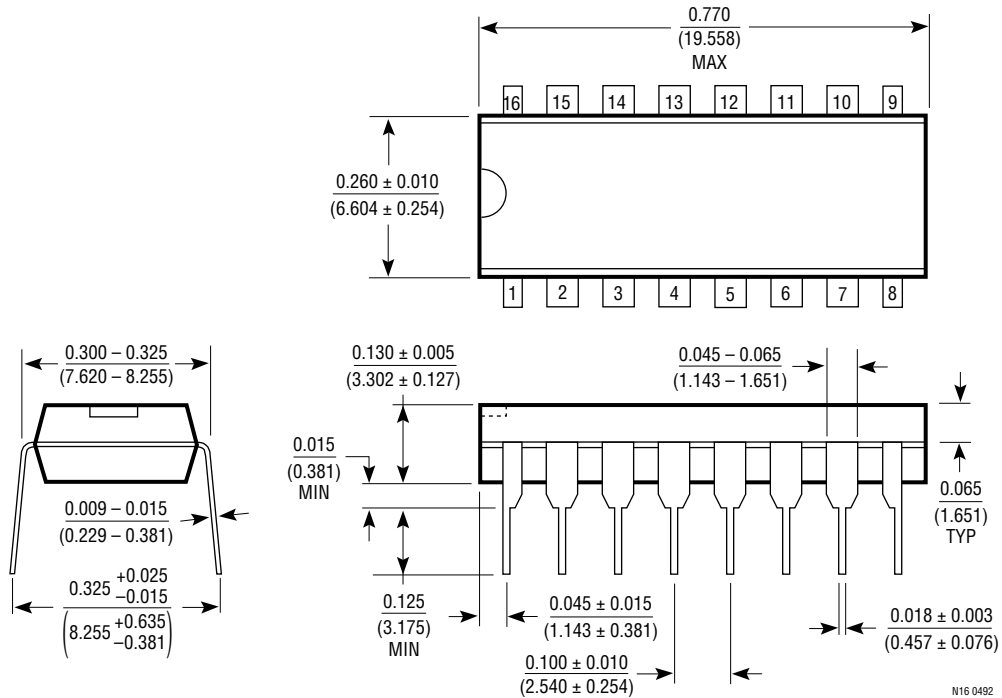

S Package
16-Lead Plastic SOIC

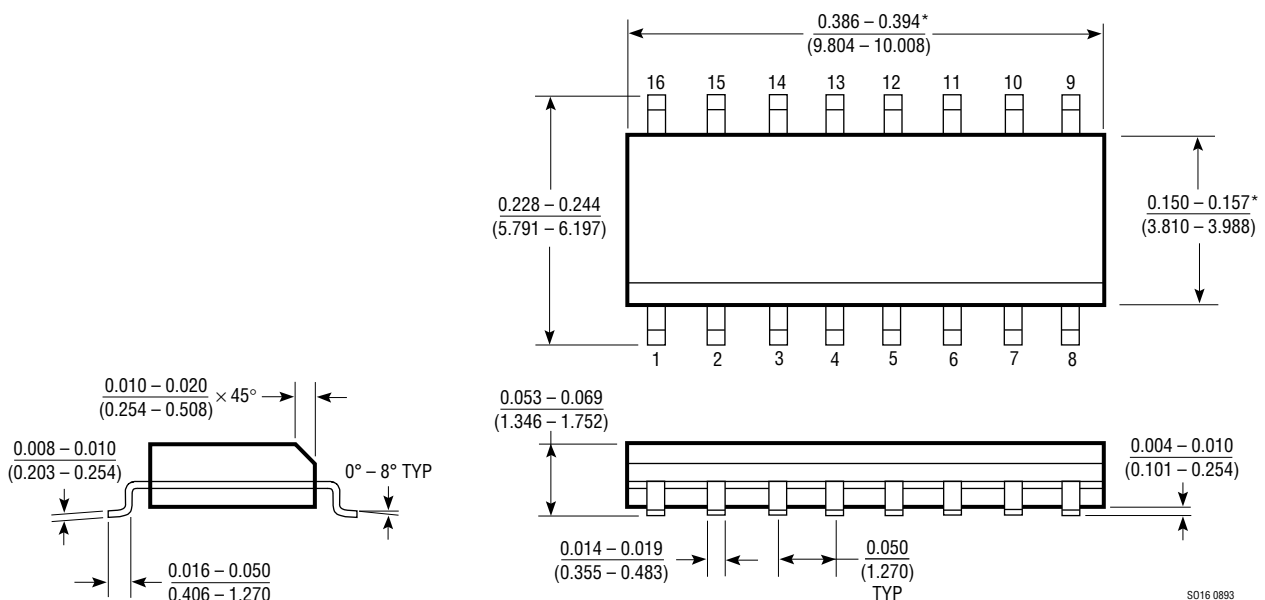

*THESE DIMENSIONS DO NOT INCLUDE MOLD FLASH OR PROTRUSIONS. MOLD FLASH OR PROTRUSIONS SHALL NOT EXCEED 0.006 INCH (0.15mm).

U.S. Area Sales Offices**NORTHEAST REGION****Linear Technology Corporation**

One Oxford Valley
2300 E. Lincoln Hwy., Suite 306
Langhorne, PA 19047
Phone: (215) 757-8578
FAX: (215) 757-5631

Linear Technology Corporation

266 Lowell St., Suite B-8
Wilmington, MA 01887
Phone: (508) 658-3881
FAX: (508) 658-2701

SOUTHEAST REGION**Linear Technology Corporation**

17060 Dallas Parkway
Suite 208
Dallas, TX 75248
Phone: (214) 733-3071
FAX: (214) 380-5138

CENTRAL REGION**Linear Technology Corporation**

Chesapeake Square
229 Mitchell Court, Suite A-25
Addison, IL 60101
Phone: (708) 620-6910
FAX: (708) 620-6977

SOUTHWEST REGION**Linear Technology Corporation**

22141 Ventura Blvd.
Suite 206
Woodland Hills, CA 91364
Phone: (818) 703-0835
FAX: (818) 703-0517

NORTHWEST REGION**Linear Technology Corporation**

782 Sycamore Dr.
Milpitas, CA 95035
Phone: (408) 428-2050
FAX: (408) 432-6331

International Sales Offices**FRANCE****Linear Technology S.A.R.L.**

Immeuble "Le Quartz"
58 Chemin de la Justice
92290 Chatenay Malabry
France
Phone: 33-1-41079555
FAX: 33-1-46314613

GERMANY**Linear Technolgy GmbH**

Untere Hauptstr. 9
D-85386 Eching
Germany
Phone: 49-89-3197410
FAX: 49-89-3194821

JAPAN**Linear Technology KK**

5F YZ Bldg.
4-4-12 Iidabashi, Chiyoda-Ku
Tokyo, 102 Japan
Phone: 81-3-3237-7891
FAX: 81-3-3237-8010

KOREA**Linear Technology Korea Branch**

Namsong Building, #505
Itaewon-Dong 260-199
Yongsan-Ku, Seoul
Korea
Phone: 82-2-792-1617
FAX: 82-2-792-1619

SINGAPORE**Linear Technology Pte. Ltd.**

101 Boon Keng Road
#02-15 Kallang Ind. Estates
Singapore 1233
Phone: 65-293-5322
FAX: 65-292-0398

TAIWAN**Linear Technology Corporation**

Rm. 801, No. 46, Sec. 2
Chung Shan N. Rd.
Taipei, Taiwan, R.O.C.
Phone: 886-2-521-7575
FAX: 886-2-562-2285

UNITED KINGDOM**Linear Technology (UK) Ltd.**

The Coliseum, Riverside Way
Camberley, Surrey GU15 3YL
United Kingdom
Phone: 44-276-677676
FAX: 44-276-64851

World Headquarters**Linear Technology Corporation**

1630 McCarthy Blvd.
Milpitas, CA 95035-7487
Phone: (408) 432-1900
FAX: (408) 434-0507

0294