

**ULTRABRIGHT HLMP-3X50A SERIES
MV3X50A SERIES**

PACKAGE DIMENSIONS

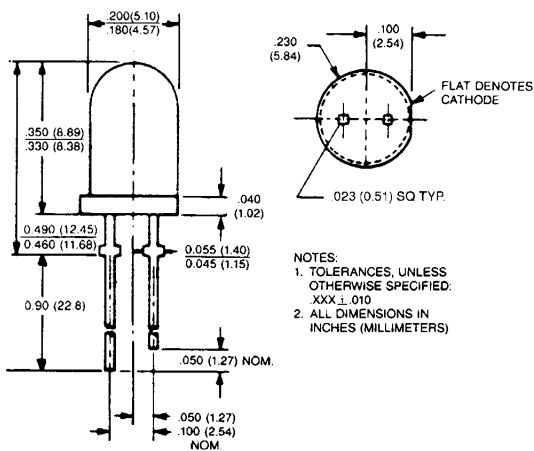

HLMP-3X50A

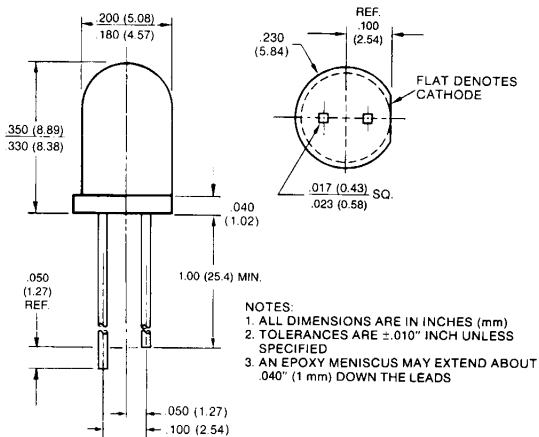

MV3X50A

DESCRIPTION

The Ultrabright HLMP-3X50A Series are direct, pin-for-pin replacements for the Hewlett-Packard devices with the same part numbers.

HLMP-3X50A in High Efficiency Red, Yellow and High Efficiency Green are very narrow viewing angle Clear lamps in a standard T-1³/₄ package.

By using more efficient LED chips, these lamps are superior in Luminous Intensity compared to other lamps.

Lamps have Pale Tinted package to aid identification.

FEATURES

- Minimum 80 mcd
- All three colors
- Pale Tint avoids mix problems
- Sturdy leads with or without stand-off on T-1³/₄
- Excellent for small area backlighting
- High Efficiency Red
HLMP-3750A
MV3750A
- High Efficiency Green
HLMP-3950A
MV3450A
- Yellow
HLMP-3850A
MV3350A



ULTRABRIGHT T-1³/₄ SOLID STATE LAMPS

ELECTRO-OPTICAL CHARACTERISTICS (T _A =25°C Unless Otherwise Specified)							
PARAMETER	SYMBOL	MV3750A HLMP-3750A	MV3350A HLMP-3850A	MV3450A HLMP-3950A	UNITS	TEST CONDITIONS	
Luminous Intensity	min.	I _v	80	80	80	mcd	I _f =20 mA
	typ.		150	150	150	mcd	I _f =20 mA
Forward voltage	max.	V _f	3.0	3.0	3.0	V	I _f =20 mA
	typ.		2.2	2.2	2.2	V	I _f =20 mA
Peak wavelength	typ.	λ _p	635	585	565	nm	I _f =10 mA
Capacitance	typ.	C	45	45	20	pF	V _r =0, f=1 MHz
Reverse breakdown voltage	min.	BV _r	5	5	5	V	I _r =100 μA
Total viewing angle between half Luminous Intensity points	typ.	2θ _{1/2}	24	24	24	degrees	

ABSOLUTE MAXIMUM RATINGS (T _A =25°C Unless Otherwise Specified)					
PARAMETER	HI. EFF. RED	YELLOW	HI. EFF. GREEN	UNITS	NOTES
Power dissipation	135	85	135	mW	1
Peak forward current	90	60	90	mA	
Average forward current	25	20	25	mA	
Continuous DC forward current	30	20	30	mA	2
Lead soldering time at 260°C	5	5	5	seconds	3
Operating and storage temperature	-55 to +100°C				

NOTES
1. For High Efficiency Red and High Efficiency Green, derate power linearly from 25°C at 1.8 mW/°C. For Yellow derate power linearly from 50°C at 1.6 mW/°C.
2. For High Efficiency Red and High Efficiency Green derate linearly from 50°C at 0.5 mA/°C. For Yellow derate linearly from 50°C at 0.2 mA/°C.
3. To a point of minimum 1/16 inch (1.6 mm) from the bottom of the lamp.

TYPICAL ELECTRO-OPTICAL CHARACTERISTIC CURVES
(25°C Free Air Temperature Unless Otherwise Specified)

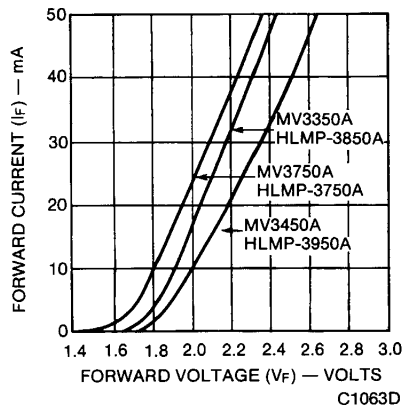

Fig. 1. Forward Voltage/
Forward Current

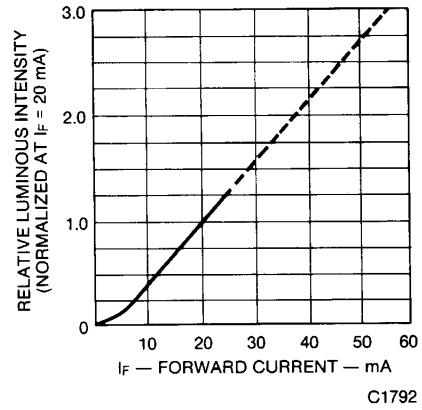

Fig. 2. Relative Luminous Intensity vs.
DC Forward Current

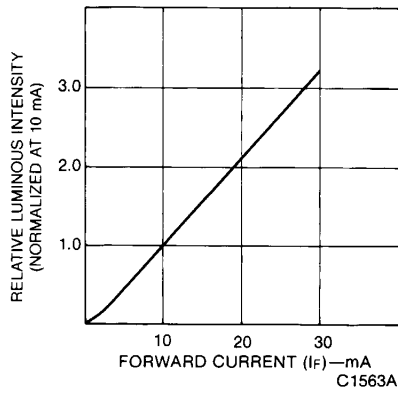

Fig. 3. Spatial Distribution

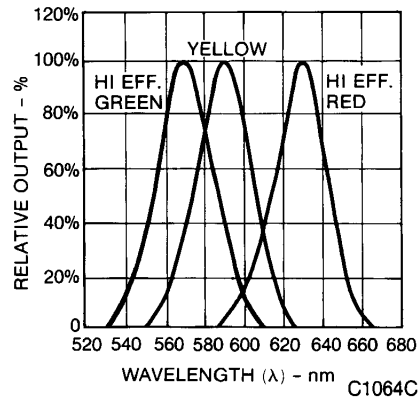

Fig. 4. Spectral Distribution