

6N137

Digital Logic Isolation
 Tele-Communication
 Analog Data Equipment Control

The TOSHIBA 6N137 consist of a high emitting diode and a one chip photo IC. This unit is 8-lead DIP package.

- LSTTL / TTL compatible: 5V Supply
- Ultra high speed: 10MBd
- Guaranteed performance over temperature: 0°C to 70°C
- High isolation voltage: 2500Vrms min.
- UL recognized: UL1577, file no. E67349

Truth Table

Input	Enable	Output
H	H	L
L	H	H
H	L	H
L	L	H

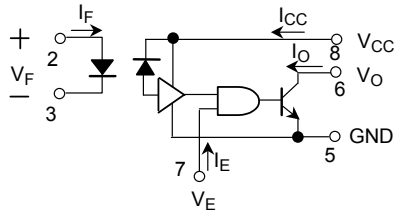

Unit in mm

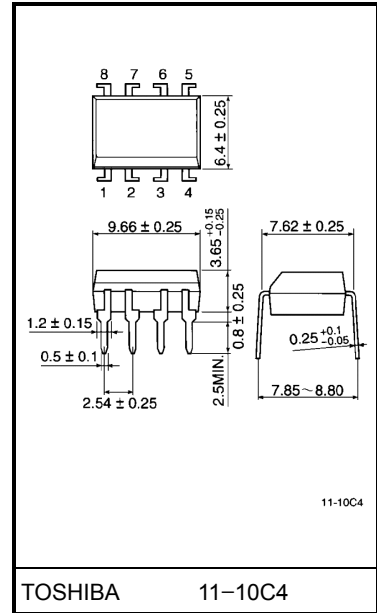

Weight: 0.54g

Pin Configurations (top view)

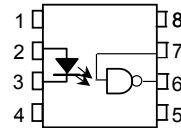

- 1 : N.C.
- 2 : Anode
- 3 : Cathode
- 4 : N.C.
- 5 : GND
- 6 : Output(Open collector)
- 7 : Enable
- 8 : V_{CC}

Absolute Maximum Ratings

Characteristic		Symbol	Rating	Unit
LED	Forward current	I_F	20	mA
	Pulse forward current (Note 1)	I_{FP}	40	mA
	Reverse voltage	V_R	5	V
Detector	Output current	I_O	50	mA
	Output voltage	V_O	7	V
	Supply voltage (1 minute maximum)	V_{CC}	7	V
	Enable input voltage (not to exceed V_{CC} by more than 500mV)	V_{EH}	5.5	V
	Output collector power dissipation	P_O	85	mW
Operating temperature range		T_{opr}	0~70	°C
Storage temperature range		T_{stg}	-55~125	°C
Lead solder temperature (10 s) (Note 2)		T_{sol}	260	°C

Note: Using continuously under heavy loads (e.g. the application of high temperature/current/voltage and the significant change in temperature, etc.) may cause this product to decrease in the reliability significantly even if the operating conditions (i.e. operating temperature/current/voltage, etc.) are within the absolute maximum ratings and the operating ranges.

Please design the appropriate reliability upon reviewing the Toshiba Semiconductor Reliability Handbook ("Handling Precautions"/"Derating Concept and Methods") and individual reliability data (i.e. reliability test report and estimated failure rate, etc).

(Note 1) 50% duty cycle, 1ms pulse width.

(Note 2) Soldering portion of lead: Up to 2mm from the body of the device.

Recommended Operating Conditions

Characteristic	Symbol	Min.	Max.	Unit
Input current, low level each channel	I_{FL}	0	250	μ A
Input current, high level each channel	I_{FH}	7	20	mA
High level enable voltage	V_{EH}	2.0	V_{CC}	V
Low level enable voltage (output high)	V_{EL}	0	0.8	V
Supply voltage, output*	V_{CC}	4.5	5.5	V
Fan out (TTL load)	N	—	8	—
Operating temperature	T_a	0	70	°C

Note: Recommended operating conditions are given as a design guideline to obtain expected performance of the device. Additionally, each item is an independent guideline respectively. In developing designs using this product, please confirm specified characteristics shown in this document.

*This item denotes operating ranges, not meaning of recommended operating conditions.

Precaution

Please be careful of the followings.

A ceramic capacitor(0.1 μ F)should be connected from pin 8 to pin 5 to stabilize the operation of the high gain linear amplifier. Failure to provide the bypassing may impair the switching property. The total lead length between capacitor and coupler should not exceed 1cm.

Electrical Characteristics Over Recommended Temperature (Ta = 0~70°C unless otherwise noted)

Characteristic	Symbol	Test Condition	Min.	(**)Typ.	Max.	Unit
High level output current	I _{OH}	V _{CC} =5.5V, V _O =5.5V I _F =250μA, V _E = 2.0V	—	1	250	μA
Low level output voltage	V _{OL}	V _{CC} =5.5V, I _F =5mA V _{EH} =2.0V I _{OL} (sinking)=13mA	—	0.4	0.6	V
High level enable current	I _{EH}	V _{CC} =5.5V, V _E =2.0V	—	-1.0	—	mA
Low level enable current	I _{EL}	V _{CC} =5.5V, V _E =0.5V	—	-1.6	-2.0	mA
High level supply current	I _{CCH}	V _{CC} =5.5V, I _F =0, V _E =0.5V	—	7	15	mA
Low level supply current	I _{CCL}	V _{CC} =5.5V, I _F =10mA V _E =0.5V	—	12	18	mA
Resistance (input-output) (Note 3)	R _{I-O}	V _{I-O} =500V, Ta=25°C R.H.≤60%	—	10 ¹²	—	Ω
Capacitance (input-output) (Note 3)	C _{I-O}	f=1MHz, Ta=25°C	—	0.6	—	pF
Input forward voltage	V _F	I _F =10mA, Ta=25°C	—	1.65	1.75	V
Input reverse breakdown voltage	BV _R	I _R =10μA, Ta=25°C	5	—	—	V
Input capacitance	C _{IN}	V _F =0, f=1MHz	—	45	—	pF
Current transfer ratio	CTR	I _F =5.0mA, R _L =100Ω	—	1000	—	%

(**) All typical values are at V_{CC}=5V, Ta=25°C

(Note 3) Pins 1, 2, 3 and 4 shorted together and pins 5, 6, 7 and 8 shorted together.

Switching Characteristics (Ta = 25°C, VCC = 5V)

Characteristic	Symbol	Test Circuit	Test Condition	Min.	Typ.	Max.	Unit
Propagation delay time to high output level	t _{pLH}	1	R _L =350Ω, C _L =15pF I _F =7.5mA	—	60	75	ns
Propagation delay time to low output level	t _{pHL}	1	R _L =350Ω, C _L =15pF I _F =7.5mA	—	60	75	ns
Output rise-fall time (10-90%)	t _r , t _f	—	R _L =350Ω, C _L =15pF I _F =7.5mA	—	30	—	ns
Propagation delay time of enable from V _{EH} to V _{EL}	t _{ELH}	2	R _L =350Ω, C _L =15pF I _F =7.5mA V _{EH} =3.0V V _{EL} =0.5V	—	25	—	ns
Propagation delay time of enable from V _{EL} to V _{EH}	t _{EHL}	2	R _L =350Ω, C _L =15pF I _F =7.5mA V _{EH} =3.0V V _{EL} =0.5V	—	25	—	ns
Common mode transient immunity at logic high output level	CM _H	3	V _{CM} =10V R _L =350Ω V _{O(min.)} =2V I _F =0mA	—	200	—	V / μs
Common mode transient immunity at logic low output level	CM _L	3	V _{CM} =10V R _L =350Ω V _{O(max.)} =0.8V I _F =5mA	—	-500	—	V / μs

Test Circuit 1.

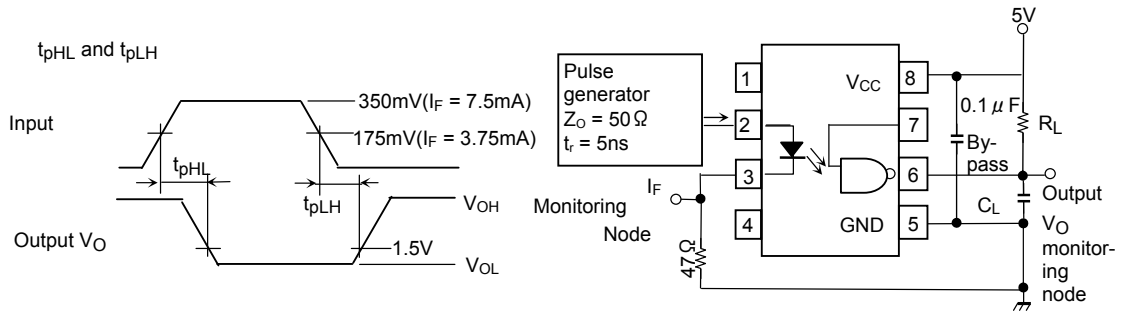

· C_L is approximately 15pF which includes probe and stray wiring capacitance.

Test Circuit 2.

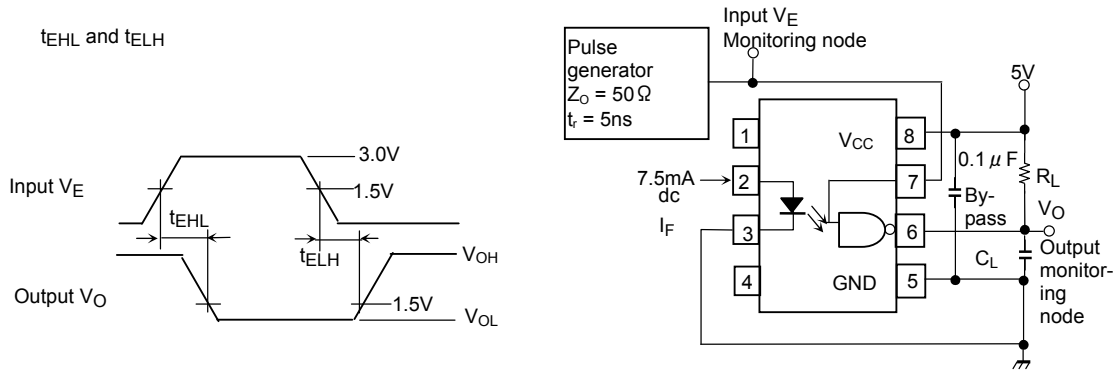

· C_L is approximately 15pF which includes probe and stray wiring capacitance.

Test Circuit 3.

Transient immunity and typical waveforms

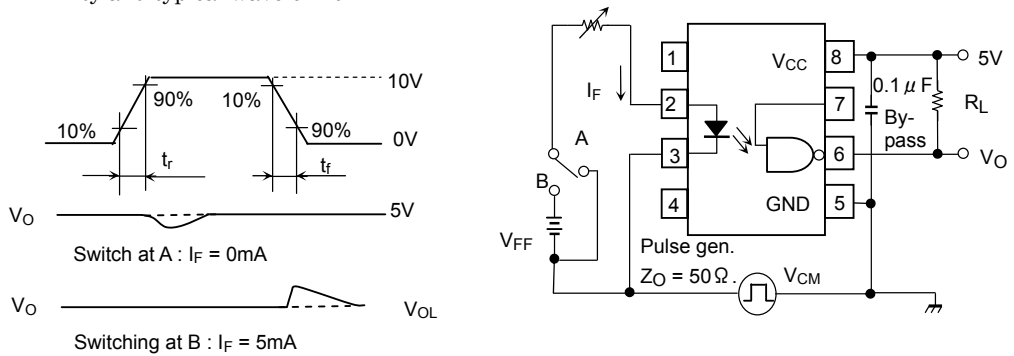

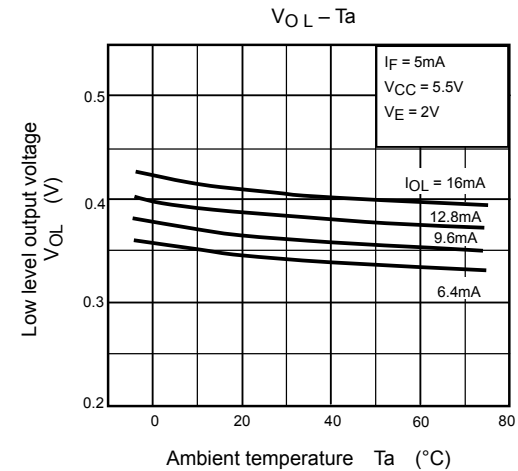
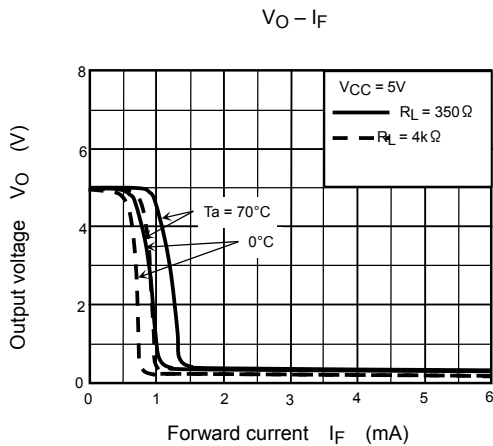
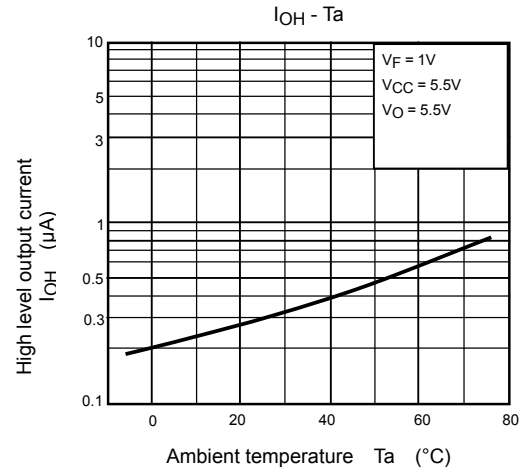
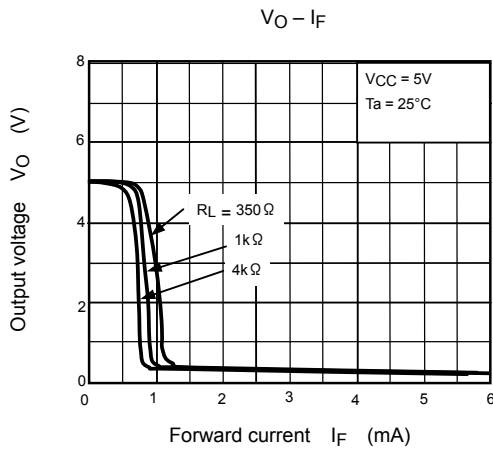
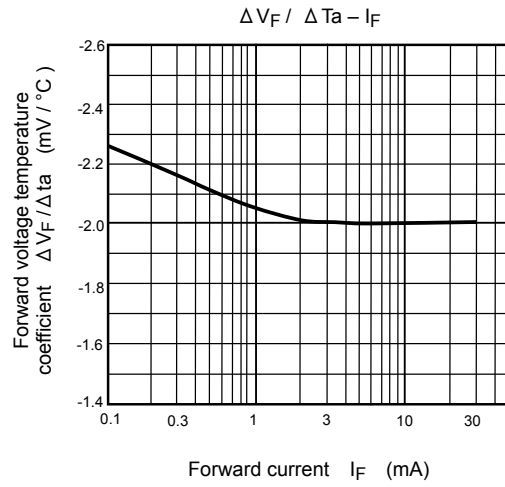
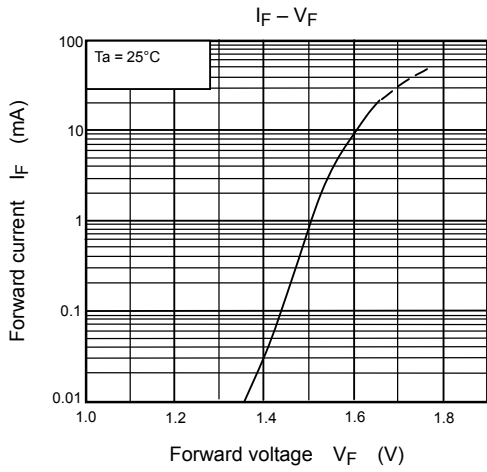

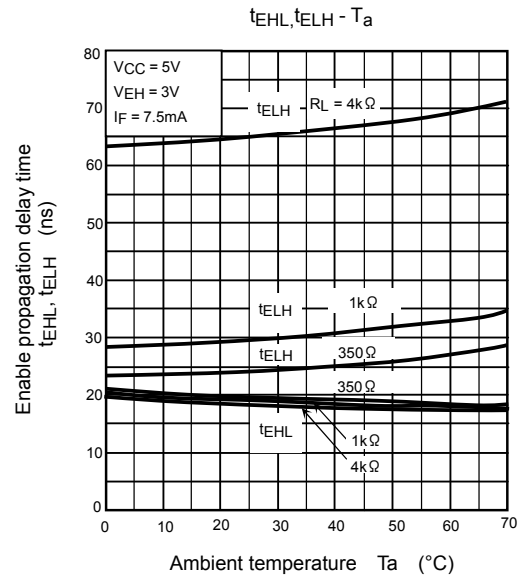
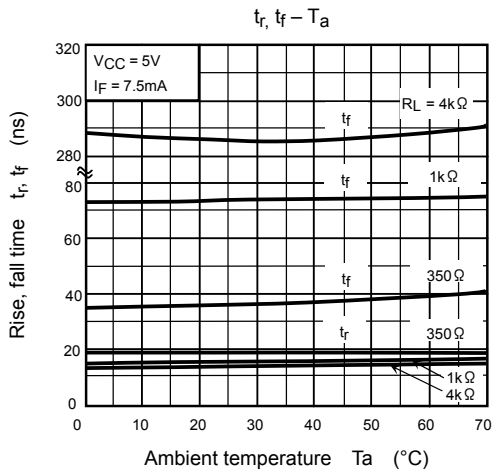
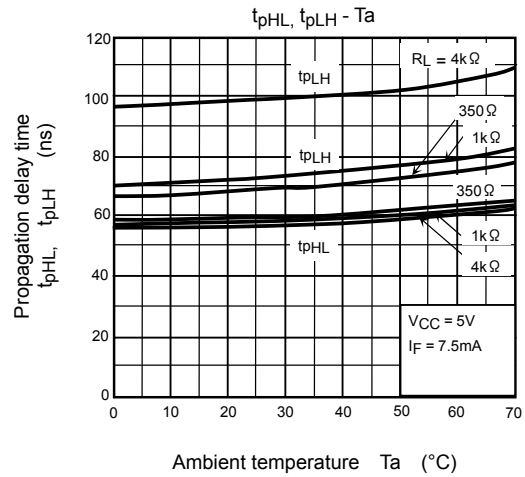
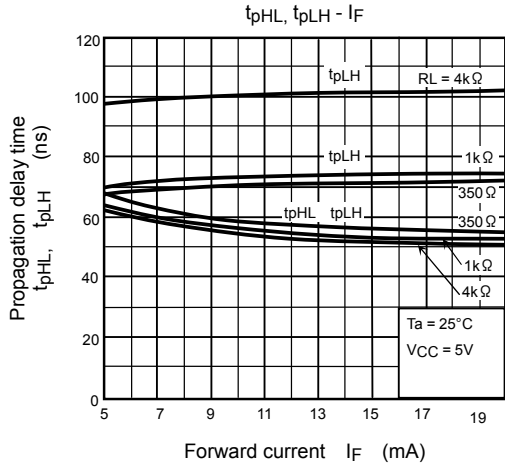

RESTRICTIONS ON PRODUCT USE

20070701-EN

- The information contained herein is subject to change without notice.
- TOSHIBA is continually working to improve the quality and reliability of its products. Nevertheless, semiconductor devices in general can malfunction or fail due to their inherent electrical sensitivity and vulnerability to physical stress. It is the responsibility of the buyer, when utilizing TOSHIBA products, to comply with the standards of safety in making a safe design for the entire system, and to avoid situations in which a malfunction or failure of such TOSHIBA products could cause loss of human life, bodily injury or damage to property.
In developing your designs, please ensure that TOSHIBA products are used within specified operating ranges as set forth in the most recent TOSHIBA products specifications. Also, please keep in mind the precautions and conditions set forth in the "Handling Guide for Semiconductor Devices," or "TOSHIBA Semiconductor Reliability Handbook" etc.
- The TOSHIBA products listed in this document are intended for usage in general electronics applications (computer, personal equipment, office equipment, measuring equipment, industrial robotics, domestic appliances, etc.). These TOSHIBA products are neither intended nor warranted for usage in equipment that requires extraordinarily high quality and/or reliability or a malfunction or failure of which may cause loss of human life or bodily injury ("Unintended Usage"). Unintended Usage include atomic energy control instruments, airplane or spaceship instruments, transportation instruments, traffic signal instruments, combustion control instruments, medical instruments, all types of safety devices, etc.. Unintended Usage of TOSHIBA products listed in this document shall be made at the customer's own risk.
- The products described in this document shall not be used or embedded to any downstream products of which manufacture, use and/or sale are prohibited under any applicable laws and regulations.
- The information contained herein is presented only as a guide for the applications of our products. No responsibility is assumed by TOSHIBA for any infringements of patents or other rights of the third parties which may result from its use. No license is granted by implication or otherwise under any patents or other rights of TOSHIBA or the third parties.
- GaAs(Gallium Arsenide) is used in this product. The dust or vapor is harmful to the human body. Do not break, cut, crush or dissolve chemically.
- Please contact your sales representative for product-by-product details in this document regarding RoHS compatibility. Please use these products in this document in compliance with all applicable laws and regulations that regulate the inclusion or use of controlled substances. Toshiba assumes no liability for damage or losses occurring as a result of noncompliance with applicable laws and regulations.