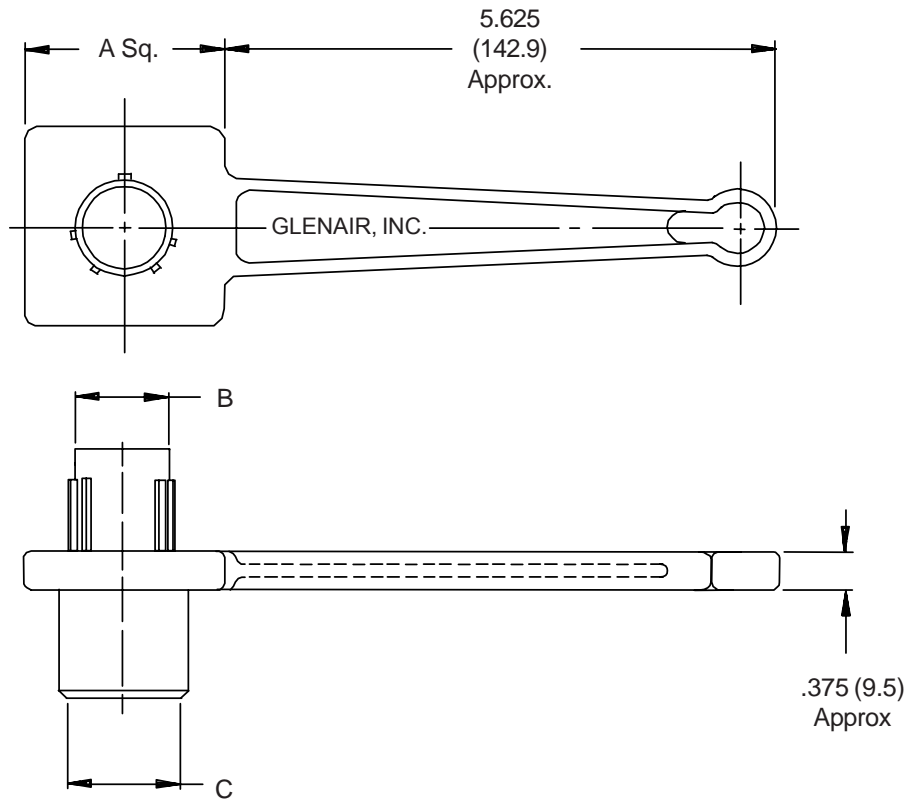

MS3482-18-6

Basic Part No.

Polarization Position
(1, 2, 3, 4, 5, 6)

Dash No.

TABLE I

Shell Size	A Dim. $\pm .060$ (1.5)	B Dia.		C Dia.	
		$+.001$ (.1)	$-.008$ (.2)	$\pm .003$ (.1)	
8	1.250 (31.8)	.381 (9.7)	.389 (9.9)		
10	1.250 (31.8)	.506 (12.9)	.514 (13.1)		
14	2.000 (50.8)	.756 (19.2)	.764 (19.4)		
16	2.000 (50.8)	.882 (22.4)	.890 (22.6)		
18	2.000 (50.8)	1.006 (25.6)	1.014 (25.8)		

1. For complete dimensions see applicable Military Specification.
2. Metric dimensions (mm) are indicated in parentheses.
3. Material: Aluminum alloy with electroless nickel finish.