

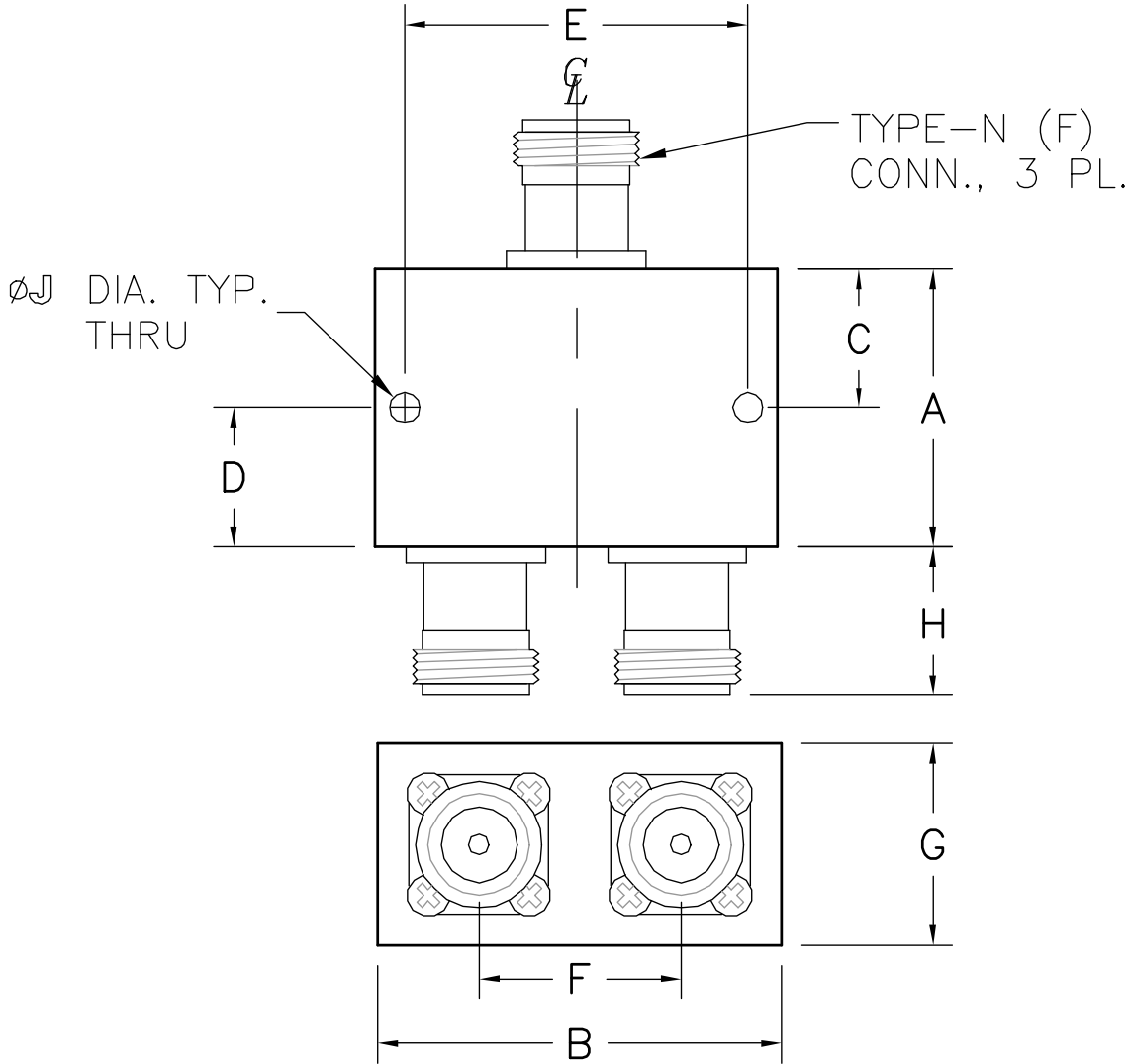
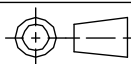

REV. A	AUTH. M.R.	DATE 2/28/00	INITIAL RELEASE	APPROVED
REV. B	AUTH. R.L.	DATE 6/4/03	REVISED TABLE LINE '5': A WAS: 1.8, B WAS: 2.0, C WAS: .90; D WAS: 1.0; E WAS: 1.31, F WAS: 1.0; G WAS: .50	APPROVED
REV. C	AUTH. R.L.	DATE 9/12/03	REVISED TABLE LINE '5': A WAS: 2.00, B WAS: 1.50, C WAS: 1.00; D WAS: 1.00; E WAS: 1.310, F WAS: 1.00; G WAS: .60	APPROVED



DIMENSIONS IN INCHES									
FIG	A	B	C	D	E	F	G	H	J
1	2.00	2.00	1.00	1.00	1.500	1.00	0.75	0.77	0.125
2	1.00	2.00	0.50	0.50	1.700	1.00	1.00	0.77	0.125
3	1.38	2.00	0.69	0.69	1.700	1.00	1.00	0.77	0.149
4	1.20	1.50	0.60	0.60	1.000	1.00	0.40	0.95	0.104
5	1.80	2.00	0.90	0.90	1.750	1.18	0.50	0.95	0.105

MATERIAL	ALUM.	TREATMENT	-	DRAWN	M. ROTUNDA	DATE	2/28/00
FINISH	ATM STD. GREY	MOD NO.	P224/P225	CHECKED		DATE	
OUTLINE, 2-WAY POWER DIVIDER, TYPE-N				APPROVED		DATE	
				CAGE CODE: OR8N4		DO NOT SCALE DWG	
ADVANCED TECHNICAL MATERIALS, INC. 49 RIDER AVE., PATCHOGUE N.Y. 11772 TEL: (631) 289-0363 FAX: (631) 289-0358 http://www.atmmicrowave.com				UNLESS OTHERWISE NOTED DIMENSIONS ARE IN INCHES TOLERANCES ARE:			SHEET.
 PROPRIETARY NOTICE: THE INFORMATION IN THIS DRAWING IS PROPRIETARY AND SHALL NOT BE USED OR DISCLOSED WITHOUT THE PRIOR WRITTEN CONSENT OF ATM, INC.				FRACTIONS ±1/64 DECIMALS ±.01 ANGLES ±1/2°		1/1	
				SCALE	1 : 1	DWG. NO.	2350W
						REV.	C