

Product Features

- DC – 4 GHz
- +18.5 dBm P1dB at 1 GHz
- +35 dBm OIP3 at 1 GHz
- 16 dB Gain at 1 GHz
- 5.5 dB Noise Figure
- Available in Lead-free / green SOT-89 Package Style
- Internally matched to 50 Ω

Applications

- Mobile Infrastructure
- CATV / FTTH
- W-LAN / ISM
- RFID
- WiMAX / WiBro

Product Description

The ECG040 is a general-purpose buffer amplifier that offers high dynamic range in a low-cost surface-mount package. At 1 GHz, the ECG040B typically provides 15.8 dB of gain, +35 dBm Output IP3, and +18.5 dBm P1dB.

The ECG040 consists of Darlington pair amplifiers using the high reliability InGaP/GaAs HBT process technology and only requires DC-blocking capacitors, a bias resistor, and an inductive RF choke for operation. The device is ideal for wireless applications and is available in a low-cost, surface-mountable lead-free/green/RoHS-compliant SOT-89 package. All devices are 100% RF and DC tested.

The broadband MMIC amplifier can be directly applied to various current and next generation wireless technologies such as GPRS, GSM, CDMA, and W-CDMA. In addition, the ECG040 will work for other various applications within the DC to 4 GHz frequency range such as CATV and mobile wireless.

Functional Diagram

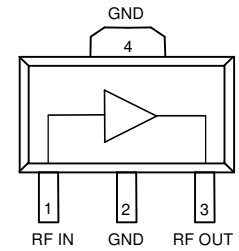

| Function | Pin No. |
|-------------|---------|
| Input | 1 |
| Output/Bias | 3 |
| Ground | 2, 4 |

Specifications ⁽¹⁾

| Parameter | Units | Min | Typ | Max |
|---------------------------|-------|------|-------|------|
| Operational Bandwidth | MHz | DC | | 4000 |
| Test Frequency | MHz | | 1000 | |
| Gain | dB | | 15.8 | |
| Output P1dB | dBm | | +18.5 | |
| Output IP3 ⁽²⁾ | dBm | | +35 | |
| Test Frequency | MHz | | 2000 | |
| Gain | dB | 12.8 | 15.3 | |
| Input Return Loss | dB | | 22 | |
| Output Return Loss | dB | | 16 | |
| Output P1dB | dBm | | +18 | |
| Output IP3 ⁽²⁾ | dBm | | +35 | |
| Noise Figure | dB | | 5.5 | |
| Device Voltage | V | | 4.8 | |
| Device Current | mA | | 70 | |

1. Test conditions unless otherwise noted: 25 °C, Supply Voltage = +6 V, Rbias = 16 Ω, 50 Ω System.
 2. 3OIP measured with two tones at an output power of +5 dBm/tone separated by 1 MHz. The suppression on the largest IM3 product is used to calculate the 3OIP using a 2:1 rule.

Typical Performance ⁽¹⁾

| Parameter | Units | Typical | | | |
|---------------------------|-------|---------|-------|-------|-------|
| Frequency | MHz | 500 | 900 | 1900 | 2140 |
| S21 | dB | 16.0 | 15.8 | 15.3 | 15.1 |
| S11 | dB | -24 | -24 | -23 | -21 |
| S22 | dB | -27 | -23 | -16 | -16 |
| Output P1dB | dBm | +18.5 | +18.5 | +18 | +19 |
| Output IP3 ⁽²⁾ | dBm | +35.5 | +35 | +34.5 | +30.5 |
| Noise Figure | dB | 4.6 | 5.5 | 5.8 | 3.8 |

Absolute Maximum Rating

| Parameter | Rating |
|-----------------------------|----------------|
| Operating Case Temperature | -40 to +85 °C |
| Storage Temperature | -65 to +150 °C |
| RF Input Power (continuous) | +12 dBm |
| Device Current | 130 mA |
| Junction Temperature | +250 °C |

Operation of this device above any of these parameters may cause permanent damage.

Ordering Information

| Part No. | Description |
|-------------|-------------------------------------------------------------------------|
| ECG040B-G | InGaP HBT Gain Block (lead-free/green/RoHS-compliant SOT-89 package) |
| ECG040B-PCB | 700–2400 MHz Fully Assembled Eval. Board |

Specifications and information are subject to change without notice

Typical Device RF Performance

Supply Bias = +6 V, $R_{bias} = 16 \Omega$, $I_{cc} = 70 \text{ mA}$

| Frequency | MHz | 100 | 500 | 900 | 1900 | 2140 | 2400 | 3500 |
|--------------|-----|-------|-------|------|-------|-------|-------|-------|
| S21 | dB | 16.2 | 16.0 | 15.8 | 15.3 | 15.1 | 14.8 | 13.9 |
| S11 | dB | -23 | -24 | -24 | -23 | -21 | -20 | -17 |
| S22 | dB | -32 | -27 | -23 | -16 | -16 | -15 | -11 |
| Output P1dB | dBm | +18.4 | +18.5 | +18 | +18 | +18 | +18 | +17.5 |
| Output IP3 | dBm | +35.6 | +35.5 | +35 | +33.2 | +32.9 | +32.4 | |
| Noise Figure | dB | 4.6 | 4.7 | 4.9 | 5.1 | 5.3 | 5.4 | |

1. Test conditions: T = 25 °C, Supply Voltage = +6 V, Device Voltage = 4.8 V, $R_{bias} = 16 \Omega$, $I_{cc} = 70 \text{ mA}$ typical, 50 Ω System.
2. 3OIP measured with two tones at an output power of +5 dBm/tone separated by 1 MHz. The suppression on the largest IM3 product is used to calculate the 3OIP using a 2:1 rule.
3. Data is shown as device performance only. Actual implementation for the desired frequency band will be determined by external components shown in the application circuit.

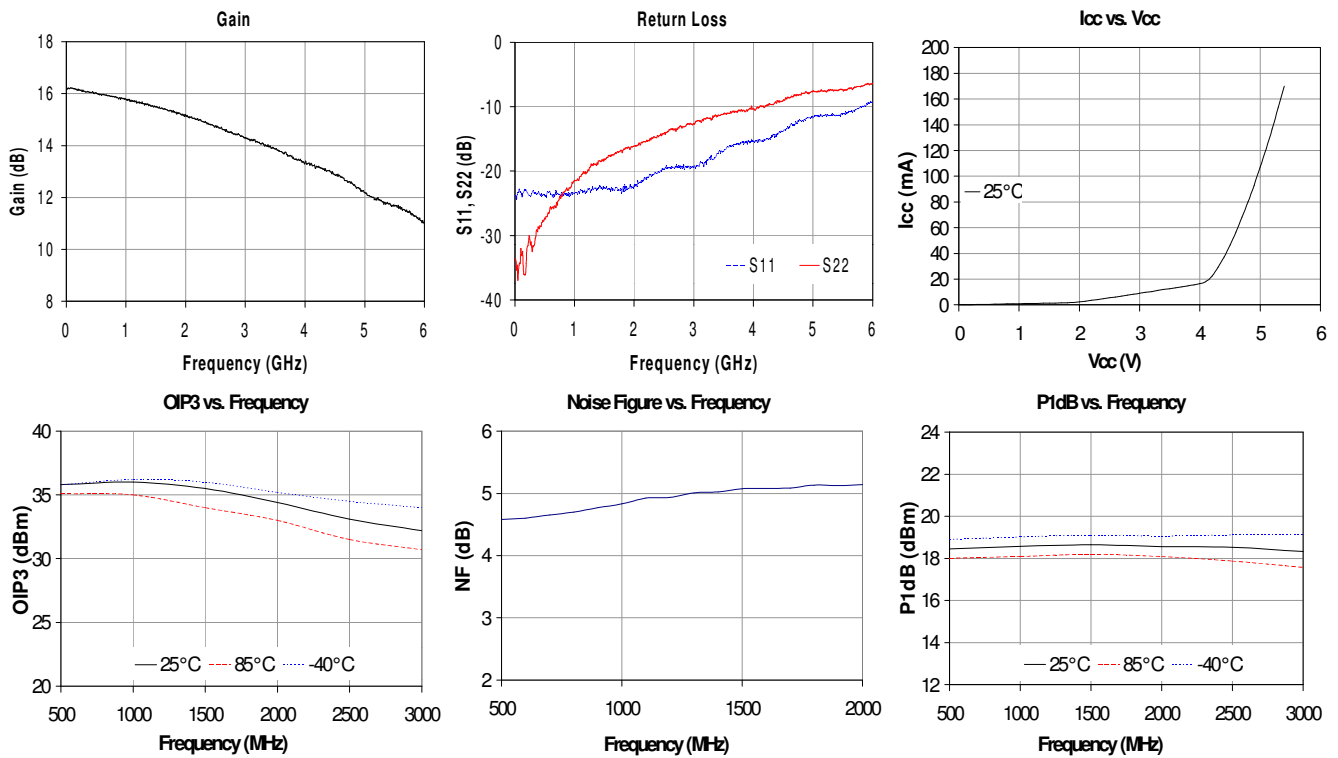

Recommended Application Circuit

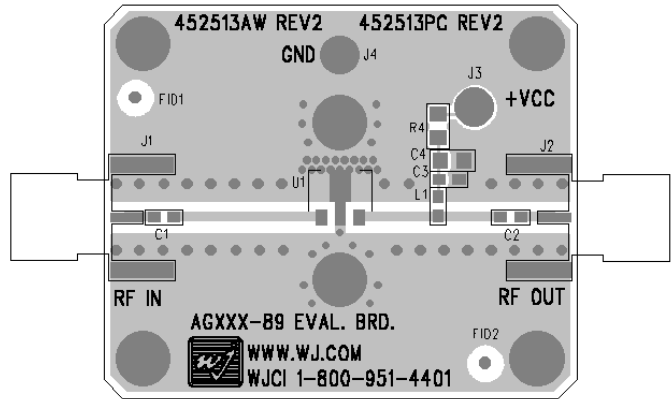
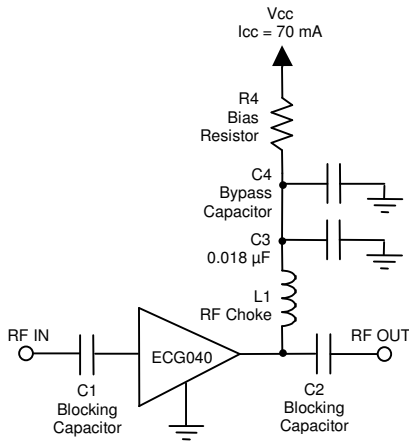

Recommended Component Values

| Reference Designator | Frequency (MHz) | | | | | | |
|----------------------|-----------------|---------|--------|-------|-------|-------|-------|
| | 50 | 500 | 900 | 1900 | 2200 | 2500 | 3500 |
| L1 | 820 nH | 220 nH | 68 nH | 27 nH | 22 nH | 18 nH | 15 nH |
| C1, C2, C4 | .018 µF | 1000 pF | 100 pF | 68 pF | 68 pF | 56 pF | 39 pF |

- The proper values for the components are dependent upon the intended frequency of operation.
- The following values are contained on the evaluation board to achieve optimal broadband performance:

| Ref. Desig. | Value / Type | Size |
|-------------|--------------------------|------|
| L1 | 39 nH wirewound inductor | 0603 |
| C1, C2 | 56 pF chip capacitor | 0603 |
| C3 | 0.018 µF chip capacitor | 0603 |
| C4 | Do Not Place | |
| R4 | 16 Ω 1% tolerance | 0805 |

Recommended Bias Resistor Values

| Supply Voltage | R1 value | Size |
|----------------|-----------|------|
| 6 V | 17.1 ohms | 0805 |
| 7 V | 31.4 ohms | 1210 |
| 8 V | 46 ohms | 1210 |
| 9 V | 60 ohms | 2010 |
| 10 V | 74 ohms | 2010 |
| 12 V | 103 ohms | 2512 |

The proper value for R1 is dependent upon the supply voltage and allows for bias stability over temperature. WJ recommends a minimum supply bias of +6 V. A 1% tolerance resistor is recommended.

Typical Device S-Parameters

S-Parameters ($V_{\text{device}} = +4.8 \text{ V}$, $I_{\text{CC}} = 70 \text{ mA}$, $T = 25 \text{ }^\circ\text{C}$, calibrated to device leads)

| Freq (MHz) | S11 (dB) | S11 (ang) | S21 (dB) | S21 (ang) | S12 (dB) | S12 (ang) | S22 (dB) | S22 (ang) |
|------------|----------|-----------|----------|-----------|----------|-----------|----------|-----------|
| 50 | -23.31 | -179.51 | 16.19 | 177.81 | -19.40 | -0.03 | -36.95 | -170.80 |
| 500 | -23.69 | 170.90 | 16.04 | 158.74 | -19.30 | -5.83 | -27.31 | -130.75 |
| 1000 | -23.45 | 162.60 | 15.79 | 138.37 | -19.12 | -12.26 | -21.40 | -141.51 |
| 1500 | -22.70 | 156.61 | 15.50 | 118.53 | -19.03 | -19.16 | -18.24 | -153.77 |
| 2000 | -22.13 | 148.64 | 15.16 | 99.02 | -18.71 | -26.80 | -16.09 | -175.02 |
| 2500 | -19.60 | 139.22 | 14.76 | 79.46 | -18.36 | -32.98 | -14.17 | 167.68 |
| 3000 | -19.24 | 121.52 | 14.31 | 61.06 | -18.13 | -41.04 | -12.61 | 152.88 |
| 3500 | -16.99 | 115.00 | 13.86 | 41.97 | -17.78 | -51.05 | -11.16 | 130.54 |
| 4000 | -15.40 | 97.66 | 13.33 | 23.55 | -17.23 | -58.84 | -10.31 | 115.55 |
| 4500 | -13.81 | 84.99 | 12.88 | 4.82 | -16.82 | -68.93 | -9.04 | 97.41 |
| 5000 | -11.78 | 64.76 | 12.19 | -13.55 | -16.84 | -79.74 | -7.54 | 76.41 |
| 5500 | -11.08 | 52.37 | 11.70 | -30.90 | -16.58 | -89.82 | -7.37 | 64.41 |
| 6000 | -9.31 | 35.87 | 10.98 | -50.95 | -16.15 | -102.41 | -6.42 | 46.46 |

Device S-parameters are available for download off of the website at: <http://www.wj.com>

ECG040B-G Mechanical Information

This package is lead-free/Green/RoHS-compliant. The plating material on the leads is NiPdAu. It is compatible with both lead-free (maximum 260 °C reflow temperature) and leaded (maximum 245 °C reflow temperature) soldering processes.

Outline Drawing

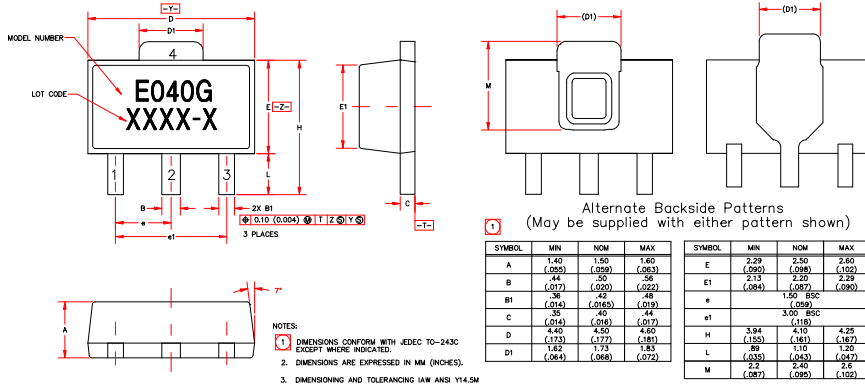

Product Marking

The component will be marked with an "E040G" designator with an alphanumeric lot code on the top surface of the package. The obsolete tin-lead package is marked with an "E040" designator followed by an alphanumeric lot code; it may also have been marked with a "J" designator followed by a 3-digit numeric lot code.

Tape and reel specifications for this part are located on the website in the "Application Notes" section.

MSL / ESD Rating



Caution! ESD sensitive device.

ESD Rating: Class 1A
Value: Passes between 250 and 500V
Test: Human Body Model (HBM)
Standard: JEDEC Standard JESD22-A114

MSL Rating: Level 3 at +260 °C convection reflow
Standard: JEDEC Standard J-STD-020

Land Pattern

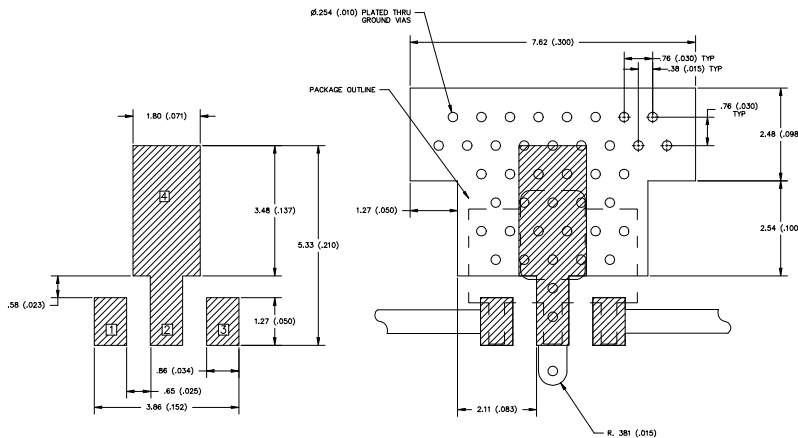

Thermal Specifications

| Parameter | Rating |
|----------------------------|---------------|
| Operating Case Temperature | -40 to +85 °C |
| Thermal Resistance, Rth | 179 °C/W |

Mounting Config. Notes

- Ground / thermal vias are critical for the proper performance of this device. Vias should use a .35mm (#80 / .0135") diameter drill and have a final plated thru diameter of .25 mm (.010").
- Add as much copper as possible to inner and outer layers near the part to ensure optimal thermal performance.
- Mounting screws can be added near the part to fasten the board to a heatsink. Ensure that the ground / thermal via region contacts the heatsink.
- Do not put solder mask on the backside of the PC board in the region where the board contacts the heatsink.
- RF trace width depends upon the PC board material and construction.
- Use 1 oz. Copper minimum.
- All dimensions are in millimeters (inches). Angles are in degrees.