



# ECG015

1/4 Watt, High Linearity InGaP HBT Amplifier

The Communications Edge™

Product Information

## Product Features

- 1800 – 2500 MHz
- +24 dBm P1dB
- +41 dBm OIP3
- 15 dB Gain
- 5 dB Noise Figure
- Single Positive Supply (+8V)
- Available in a lead-free / green SOT-89 Package Style

## Product Description

The ECG015 is a high dynamic range driver amplifier in a low-cost surface mount package. The InGaP/GaAs HBT is able to achieve performance over a broad range with +41 dBm OIP3 and +24 dBm of compressed 1dB power and is housed in a lead-free/green/RoHS-compliant SOT-89 SMT package. All devices are 100% RF and DC tested.

The product is targeted for use as a gain block/driver amplifier for various current and next generation wireless technologies such as GPRS, UMTS and WCDMA, where high linearity and medium power is required. In addition, the ECG015 will work for numerous other applications within the 1800 to 2500 MHz frequency range.

## Functional Diagram

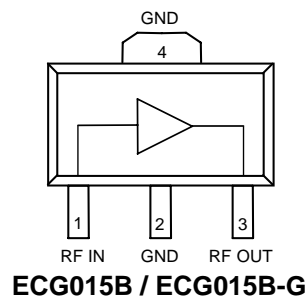

## Applications

- Mobile Infrastructure
- W-LAN / ISM
- RFID
- Defense / Homeland Security
- Fixed Wireless

## Specifications <sup>(1)</sup>

Parameter	Units	Min	Typ	Max
Operational Bandwidth	MHz	1800		2500
Test Frequency	MHz		2140	
Gain	dB	13.5	15	
Input Return Loss	dB		17	
Output Return Loss	dB		10	
Output P1dB	dBm	+22	+24	
Output IP3 <sup>(2)</sup>	dBm	+37.5	+41	
Noise Figure	dB		5	
Device Voltage	V		5	
Device Current	mA	85	100	135

1. Test conditions unless otherwise noted: 25 °C, Vsupply = +8V, in tuned application circuit with Rbias = 30 Ω.
2. 3OIP measured with two tones at an output power of +9Bm/tone separated by 1 MHz. The suppression on the largest IM3 product is used to calculate the 3OIP using a 2:1 rule.

## Typical Performance <sup>(3)</sup>

Parameter	Units	Typical		
Frequency	MHz	1900	2140	2450
S21	dB	21	15	14
S11	dB	-15	-17	-19
S22	dB	-10	-10	-10
Output P1dB	dBm	+24	+24	+23
Output IP3 <sup>(2)</sup>	dBm	+41	+41	+42
Noise Figure	dB	5	5	5

3. Typical parameters reflect performance in a tuned application circuit: Supply Voltage = +8 V, Icc = 100 mA, +25° C, Rbias = 30 Ω.

## Absolute Maximum Rating

Parameter	Rating
Operating Case Temperature	-40 to +85 °C
Storage Temperature	-55 to +125 °C
Device Current	180 mA
RF Input Power (continuous)	+15 dBm
Junction Temperature	+250 °C

Operation of this device above any of these parameters may cause permanent damage.

## Ordering Information

Part No.	Description
ECG015B	0.2 Watt, High Linearity InGaP HBT Amplifier (lead SOT-89 Pkg)
ECG015B-G	0.2 Watt, High Linearity InGaP HBT Amplifier (lead-free/green/RoHS-compliant SOT-89 Pkg)
ECG015B-PCB1900	1900 MHz Fully Assembled Eval. Board
ECG015B-PCB2140	2140 MHz Fully Assembled Eval. Board

Specifications and information are subject to change without notice



### Typical Device Data

S-parameters ( $V_{device} = +5V$ ,  $I_{cc} = 100\text{ mA}$ ,  $25^\circ\text{ C}$ , unmatched 50 ohm system)

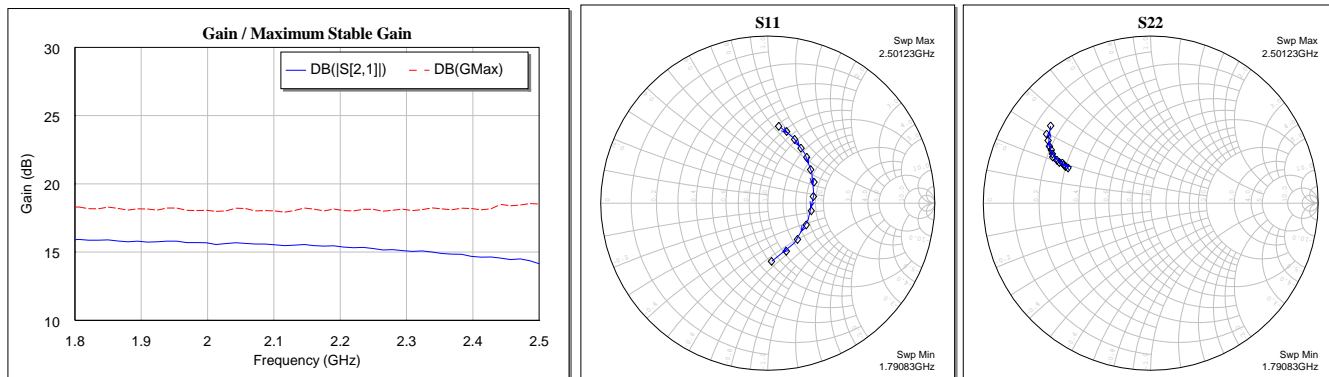

Notes:

The gain for the unmatched device in 50 ohm system is shown as the trace in blue color. For a tuned circuit for a particular frequency, it is expected that actual gain will be higher, up to the maximum stable gain. The maximum stable gain is shown in the dashed red line. The impedance plots are shown from 1800 – 2500 MHz, with markers placed at 1.8 – 2.5 GHz in 0.1 GHz increments.

S-Parameters ( $V_{device} = +5\text{ V}$ ,  $I_{cc} = 100\text{ mA}$ ,  $T = 25^\circ\text{ C}$ , unmatched 50 ohm system, calibrated to device leads)

Freq (MHz)	S11 (dB)	S11 (ang)	S21 (dB)	S21 (ang)	S12 (dB)	S12 (ang)	S22 (dB)	S22 (ang)
1800	-6.70	80.76	15.90	24.47	-28.55	-25.74	-5.34	156.39
1900	-7.55	68.30	15.77	16.51	-28.96	-32.29	-4.96	156.21
2000	-8.60	53.47	15.66	7.76	-30.14	-38.84	-4.56	155.58
2100	-9.85	35.06	15.53	-1.19	-31.49	-45.79	-4.12	155.07
2200	-11.07	10.07	15.40	-10.90	-33.04	-59.63	-3.67	153.49
2300	-11.69	-21.71	15.08	-20.90	-36.28	-78.21	-3.20	150.85
2400	-10.87	-56.13	14.67	-31.83	-40.69	-106.46	-2.80	147.22
2500	-9.15	-86.03	14.14	-43.53	-42.21	163.73	-2.44	142.35

Device S-parameters are available for download off of the website at: <http://www.wj.com>

### Application Circuit PC Board Layout

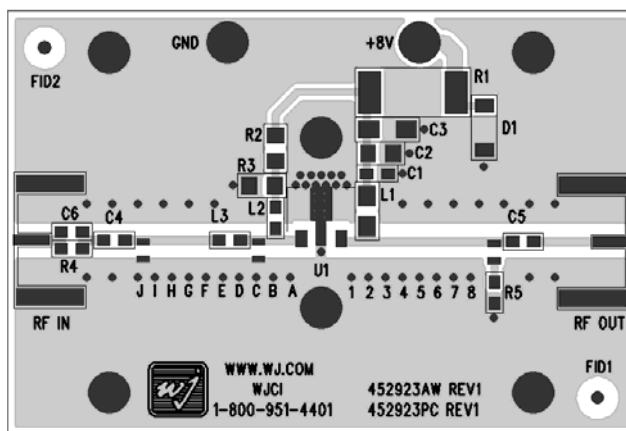

Circuit Board Material: .014" Getek, 4 - layer, 1 oz copper, Microstrip line details: width = .026", spacing = .026"  
 The silk screen markers 'A', 'B', 'C', etc. and '1', '2', '3', etc. are used as placemarkers for the input and output tuning shunt capacitors. The markers and vias are spaced in .050" increments.



### Typical Device RF Performance Supply Bias = +8 V, $R_{bias} = 30 \Omega$ , $I_{cc} = 100 \text{ mA}$

1. Test conditions: T = 25°C, Supply Voltage = +8 V, Device Voltage = 5.0 V,  $R_{bias} = 30 \Omega$ ,  $I_{cc} = 100 \text{ mA}$  typical, 50  $\Omega$  System.
2. 3OIP measured with two tones at an output power of +11 dBm/tone separated by 1 MHz. The suppression on the largest IM3 product is used to calculate the 3OIP using a 2:1 rule.
3. Data is shown as device performance only. Actual implementation for the desired frequency band will be determined by external components shown in the application circuit.

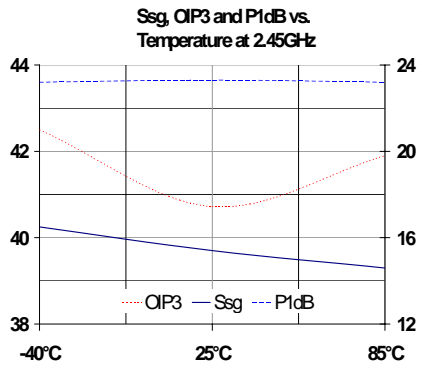
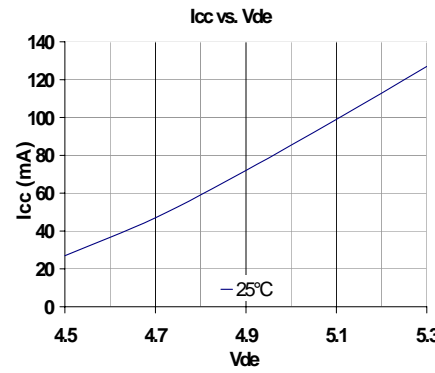
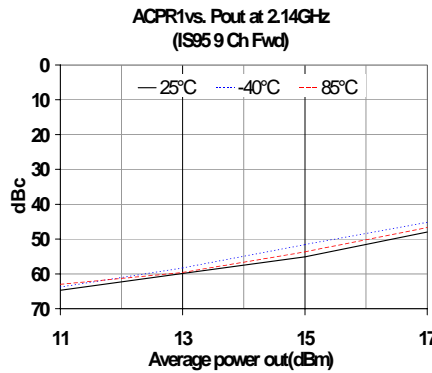
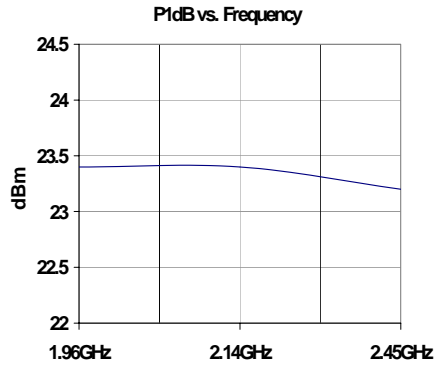
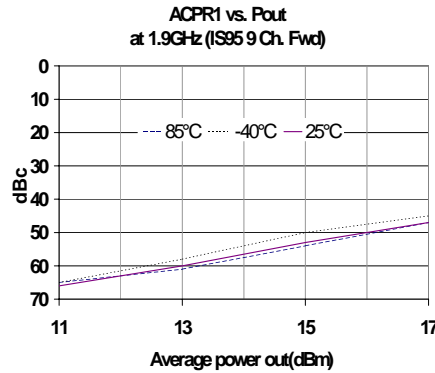
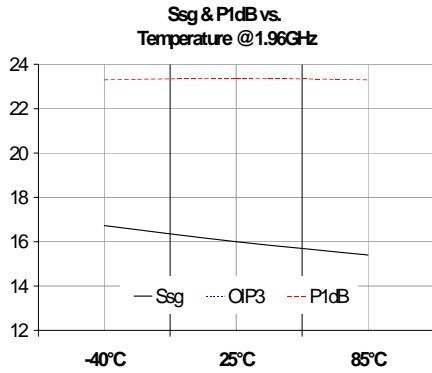



## ECG015B (SOT-89 Package) Mechanical Information

This package may contain lead-bearing materials.

### Outline Drawing

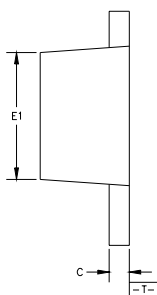
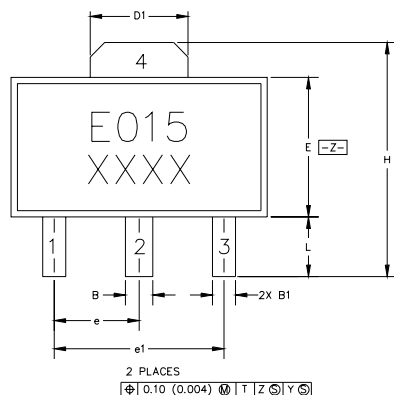

SYMBOL	MIN	MAX
A	1.40 (.055)	1.60 (.063)
B	.44 (.017)	.56 (.022)
B1	.36 (.014)	.48 (.019)
C	.35 (.014)	.44 (.017)
D	4.40 (.173)	4.60 (.181)
D1	1.62 (.064)	1.83 (.072)
E	2.29 (.079)	2.60 (.102)
E1	2.13 (.084)	2.29 (.090)
e	1.50 BSC (.059)	
e1	3.00 BSC (.118)	
H	3.94 (.155)	4.25 (.167)
L	.89 (.035)	1.20 (.047)
M	4.04 (.159)	4.19 (.165)

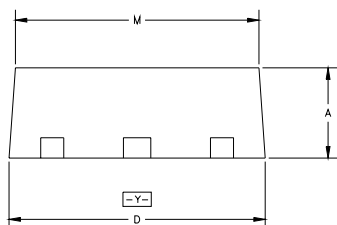

- NOTES:
1. DIMENSIONS CONFORM WITH JEDEC TO-243C EXCEPT WHERE INDICATED.
  2. DIMENSIONS ARE EXPRESSED IN MILLIMETERS(INCHES).
  3. DIMENSIONING AND TOLERANCING IAW ANSI Y14.5M

### Product Marking

The component will be marked with an "E015" designator with an alphanumeric lot code on the top surface of the package.

Tape and reel specifications for this part are located on the website in the "Application Notes" section.

### ESD / MSL Information

ESD Rating: Class 1B  
 Value: Passes at between 500 and 1000V  
 Test: Human Body Model (HBM)  
 Standard: JEDEC Standard JESD22-A114

MSL Rating: Level 3 at +240 °C convection reflow  
 Standard: JEDEC Standard J-STD-020



Caution! ESD sensitive device.

### Mounting Config. Notes

1. Ground / thermal vias are critical for the proper performance of this device. Vias should use a .35mm (#80 / .0135") diameter drill and have a final plated thru diameter of .25 mm (.010").
2. Add as much copper as possible to inner and outer layers near the part to ensure optimal thermal performance.
3. Mounting screws can be added near the part to fasten the board to a heatsink. Ensure that the ground / thermal via region contacts the heatsink.
4. Do not put solder mask on the backside of the PC board in the region where the board contacts the heatsink.
5. RF trace width depends upon the PC board material and construction.
6. Use 1 oz. Copper minimum.
7. All dimensions are in millimeters (inches). Angles are in degrees.

### Land Pattern

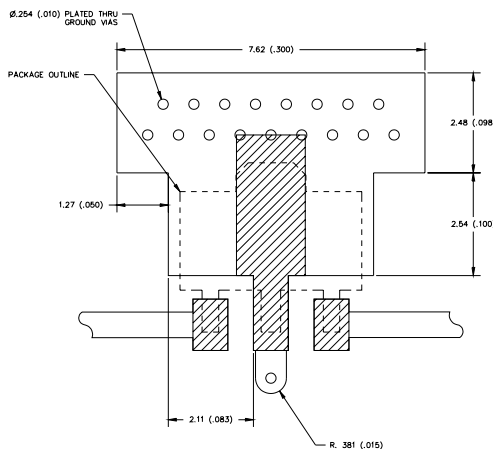
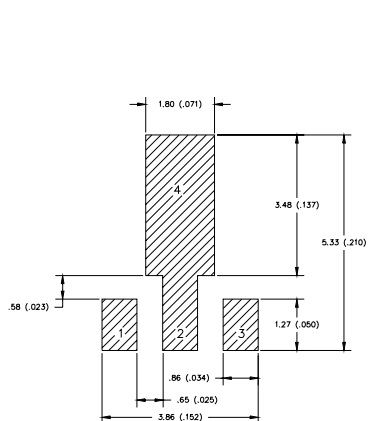

### Thermal Specifications

Parameter	Rating
Operating Case Temperature	-40 to +85° C
Thermal Resistance, Rth <sup>(1)</sup>	128° C / W
Junction Temperature, Tjc <sup>(2)</sup>	149° C

Notes:

1. The thermal resistance is referenced from the junction-to-case at a case temperature of 85° C.
2. This corresponds to the typical biasing condition of +5V, 100 mA at an 85° C case temperature. A minimum MTTF of 1 million hours is achieved for junction temperatures below 247° C.

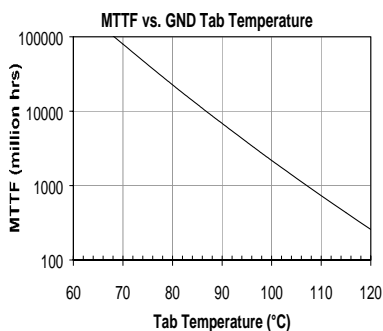

Specifications and information are subject to change without notice



## ECG015B (Green / Lead-free SOT-89 Package) Mechanical Information

This package is lead-free/Green/RoHS-compliant. It is compatible with both lead-free (maximum 260°C reflow temperature) and leaded (maximum 245°C reflow temperature) soldering processes.

### Outline Drawing

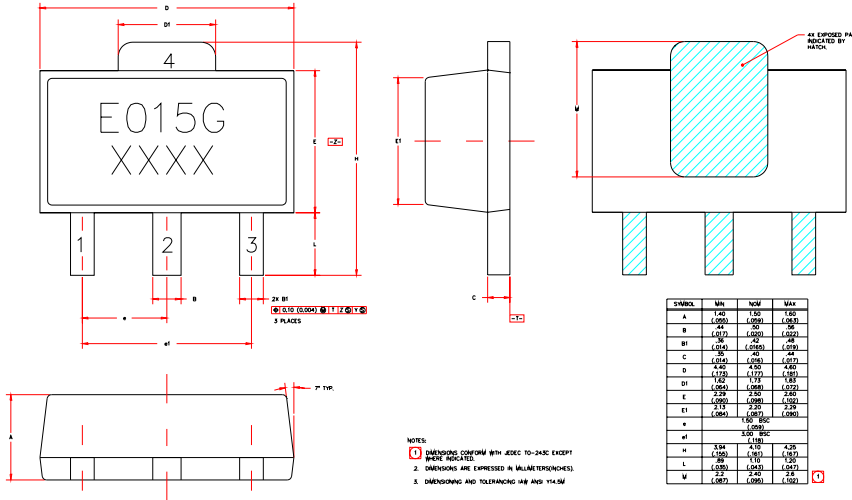

### Product Marking

The component will be marked with an "E015G" designator with an alphanumeric lot code on the top surface of the package.

Tape and reel specifications for this part are located on the website in the "Application Notes" section.

### ESD / MSL Information

ESD Rating: Class 1B  
 Value: Passes at between 500 and 1000V  
 Test: Human Body Model (HBM)  
 Standard: JEDEC Standard JESD22-A114

MSL Rating: Level 3 at +260°C convection reflow  
 Standard: JEDEC Standard J-STD-020



Caution! ESD sensitive device.

### Land Pattern

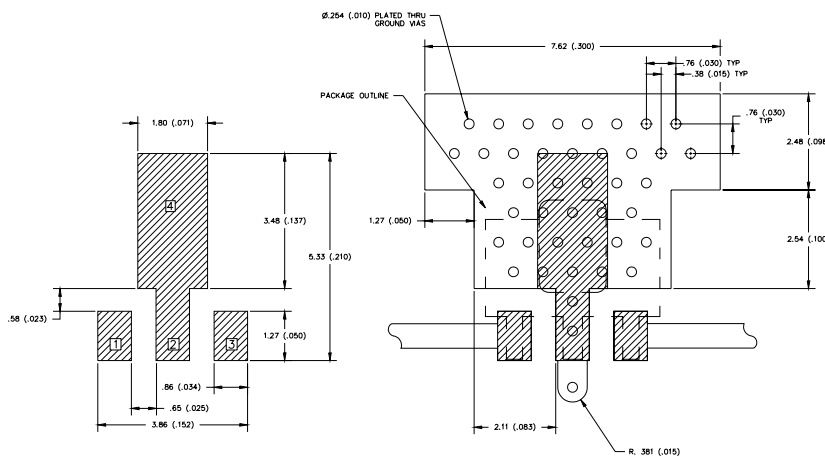

### Mounting Config. Notes

1. Ground / thermal vias are critical for the proper performance of this device. Vias should use a .35mm (#80 / .0135") diameter drill and have a final plated thru diameter of .25 mm (.010").
2. Add as much copper as possible to inner and outer layers near the part to ensure optimal thermal performance.
3. Mounting screws can be added near the part to fasten the board to a heatsink. Ensure that the ground / thermal via region contacts the heatsink.
4. Do not put solder mask on the backside of the PC board in the region where the board contacts the heatsink.
5. RF trace width depends upon the PC board material and construction.
6. Use 1 oz. Copper minimum.
7. All dimensions are in millimeters (inches). Angles are in degrees.

### Thermal Specifications

Parameter	Rating
Operating Case Temperature	-40 to +85° C
Thermal Resistance, Rth <sup>(1)</sup>	128° C / W
Junction Temperature, Tjc <sup>(2)</sup>	149° C

Notes:

1. The thermal resistance is referenced from the junction-to-case at a case temperature of 85° C.
2. This corresponds to the typical biasing condition of +5V, 100 mA at an 85° C case temperature. A minimum MTTF of 1 million hours is achieved for junction temperatures below 247° C.

