

SKiIP 26NAB065V1

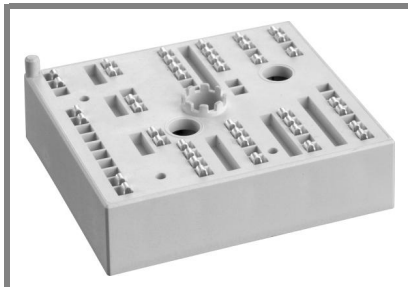

MiniSKiIP[®] 2

3-phase bridge rectifier +
brake chopper + 3-phase
bridge inverter
SKiIP 26NAB065V1

Features

- Ultrafast NPT IGBTs
- Robust and soft freewheeling diodes in CAL technology
- Highly reliable spring contacts for electrical connections
- UL recognised file no. E63532

Typical Applications

- Inverter up to 12,5 kVA
- Typical motor power 5,5 kW

Remarks

- V_{CEsat} , V_F = chip level value

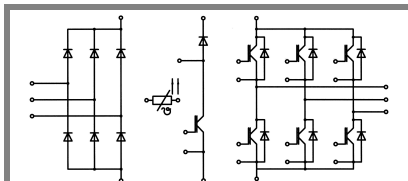

NAB

Absolute Maximum Ratings		$T_c = 25^\circ\text{C}$, unless otherwise specified	
Symbol	Conditions	Values	Units
IGBT - Inverter, Chopper			
V_{CES}		600	V
I_C	$T_s = 25 (70)^\circ\text{C}$	56 (42)	A
I_{CRM}	$t_p \leq 1 \text{ ms}$	100	A
V_{GES}		± 20	V
T_j		- 40 ... + 150	$^\circ\text{C}$
Diode - Inverter, Chopper			
I_F	$T_s = 25 (70)^\circ\text{C}$	40 (30)	A
I_{FRM}	$t_p \leq 1 \text{ ms}$	100	A
T_j		- 40 ... + 150	$^\circ\text{C}$
Diode - Rectifier			
V_{RRM}		800	V
I_F	$T_s = 70^\circ\text{C}$	61	A
I_{FSM}	$t_p = 10 \text{ ms}$, $\sin 180^\circ$, $T_j = 25^\circ\text{C}$	700	A
i^2t	$t_p = 10 \text{ ms}$, $\sin 180^\circ$, $T_j = 25^\circ\text{C}$	2400	A^2s
T_j		- 40 ... + 150	$^\circ\text{C}$
I_{RMS}	per power terminal (20 A / spring)	60	A
T_{stg}	$T_{op} \leq T_{stg}$	- 40 ... + 125	$^\circ\text{C}$
V_{isol}	AC, 1 min.	2500	V

Characteristics		$T_c = 25^\circ\text{C}$, unless otherwise specified			
Symbol	Conditions	min.	typ.	max.	Units
IGBT - Inverter, Chopper					
V_{CEsat}	$I_{Cnom} = 50 \text{ A}$, $T_j = 25 (125)^\circ\text{C}$		2 (2,2)	2,5 (2,7)	V
$V_{GE(th)}$	$V_{GE} = V_{CE}$, $I_C = 1 \text{ mA}$	3	4	5	V
$V_{CE(TO)}$	$T_j = 25 (125)^\circ\text{C}$		1,2 (1,1)	1,3 (1,2)	V
r_T	$T_j = 25 (125)^\circ\text{C}$		16 (22)	24 (30)	$\text{m}\Omega$
C_{ies}	$V_{CE} = 25 \text{ V}$, $V_{GE} = 0 \text{ V}$, $f = 1 \text{ MHz}$		2,7		nF
C_{oes}	$V_{CE} = 25 \text{ V}$, $V_{GE} = 0 \text{ V}$, $f = 1 \text{ MHz}$		0,8		nF
C_{res}	$V_{CE} = 25 \text{ V}$, $V_{GE} = 0 \text{ V}$, $f = 1 \text{ MHz}$		0,6		nF
$R_{th(j-s)}$	per IGBT		0,75		K/W
$t_{d(on)}$	under following conditions		35		ns
t_r	$V_{CC} = 300 \text{ V}$, $V_{GE} = \pm 15 \text{ V}$		35		ns
$t_{d(off)}$	$I_{Cnom} = 50 \text{ A}$, $T_j = 125^\circ\text{C}$		240		ns
t_f	$R_{Gon} = R_{Goff} = 15 \Omega$		25		ns
E_{on}	inductive load		1,3		mJ
E_{off}			0,9		mJ
Diode - Inverter, Chopper					
$V_F = V_{EC}$	$I_{Fnom} = 50 \text{ A}$, $T_j = 25 (125)^\circ\text{C}$		1,9 (1,9)	2,3 (2,4)	V
$V_{(TO)}$	$T_j = 25 (125)^\circ\text{C}$		1 (0,9)	1,1 (1)	V
r_T	$T_j = 25 (125)^\circ\text{C}$		18 (20)	24 (28)	$\text{m}\Omega$
$R_{th(j-s)}$	per diode		1,5		K/W
I_{RRM}	under following conditions		42		A
Q_{rr}	$I_{Fnom} = 50 \text{ A}$, $V_R = 300 \text{ V}$		3,6		μC
E_{rr}	$V_{GE} = 0 \text{ V}$, $T_j = 125^\circ\text{C}$		0,8		mJ
	$di_F/dt = 1500 \text{ A}/\mu\text{s}$				
Diode - Rectifier					
V_F	$I_{Fnom} = 35 \text{ A}$, $T_j = 25^\circ\text{C}$		1,1		V
$V_{(TO)}$	$T_j = 150^\circ\text{C}$		0,8		V
r_T	$T_j = 150^\circ\text{C}$		11		$\text{m}\Omega$
$R_{th(j-s)}$	per diode		0,9		K/W
Temperature Sensor					
R_{ts}	3 %, $T_r = 25 (100)^\circ\text{C}$		1000(1670)		Ω
Mechanical Data					
w			65		g
M_s	Mounting torque	2		2,5	Nm

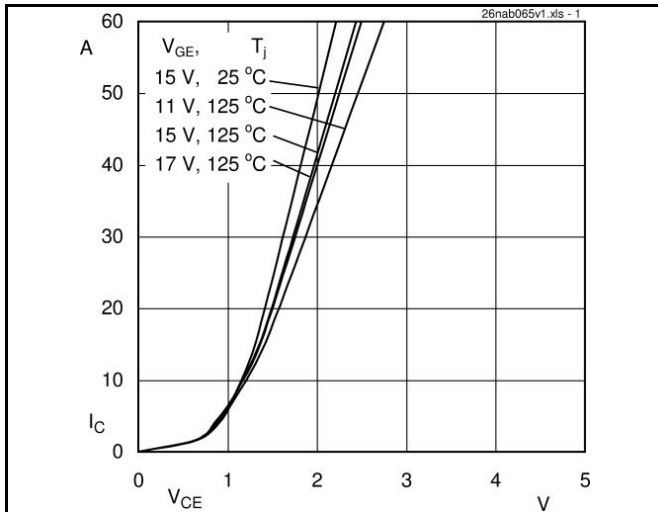

Fig. 1 Typ. output characteristic

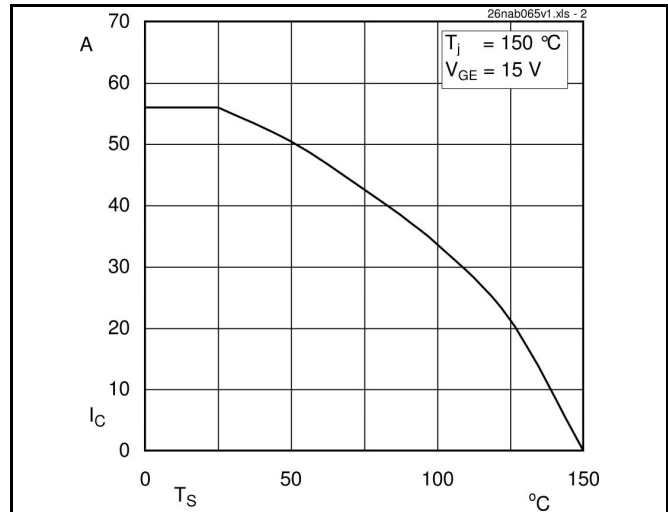

Fig. 2 Typ. rated current vs. temperature

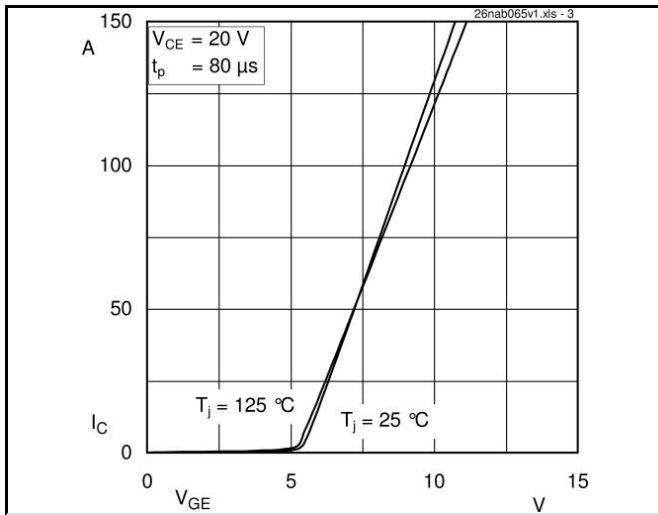

Fig. 3 Typ. transfer characteristic

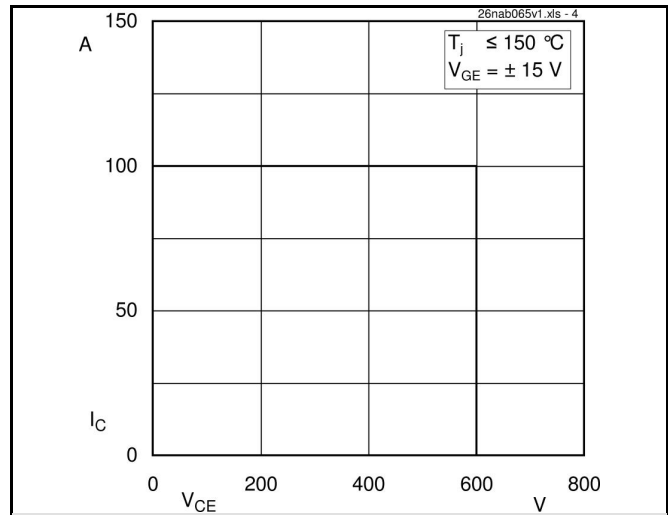

Fig. 4 Reverse bias safe operating area

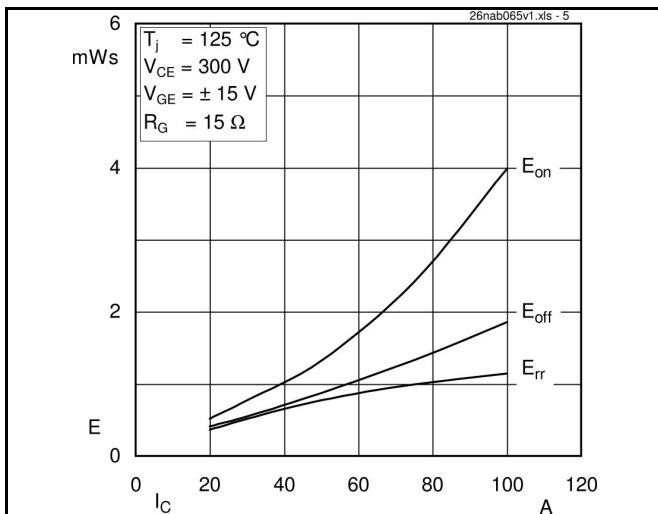

Fig. 5 Typ. Turn-on /-off energy = $f(I_C)$

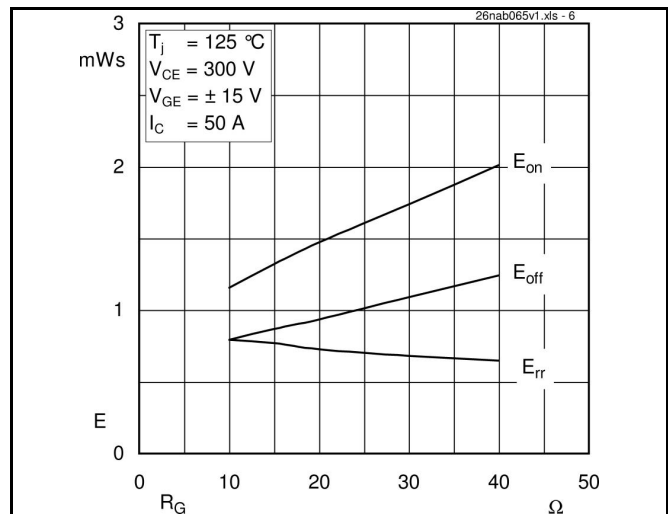
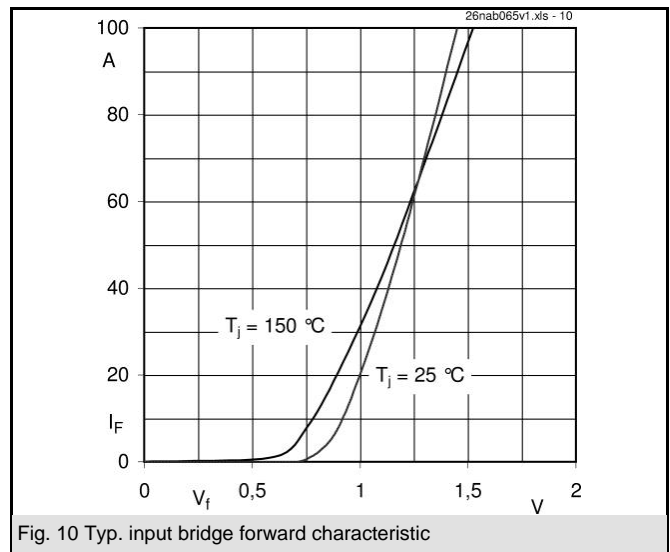
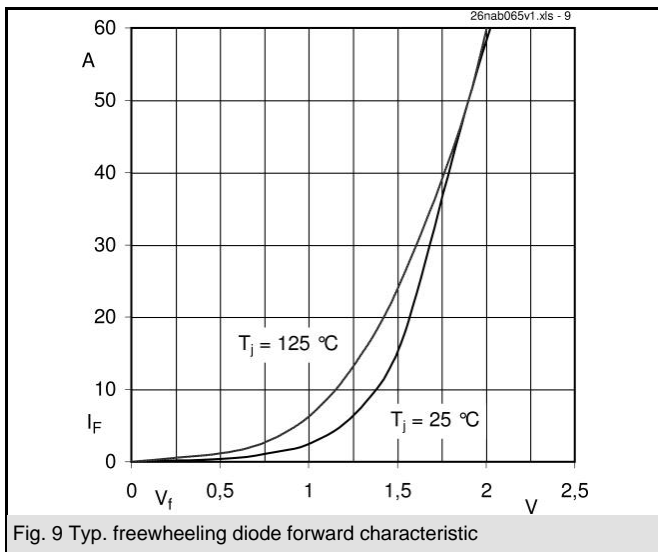
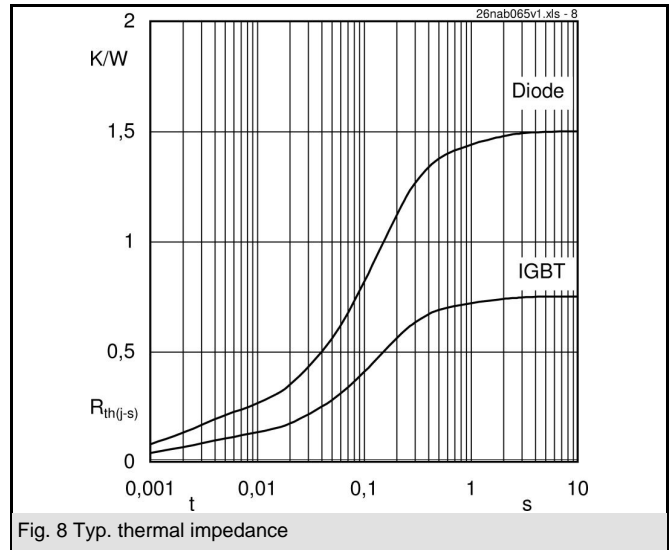
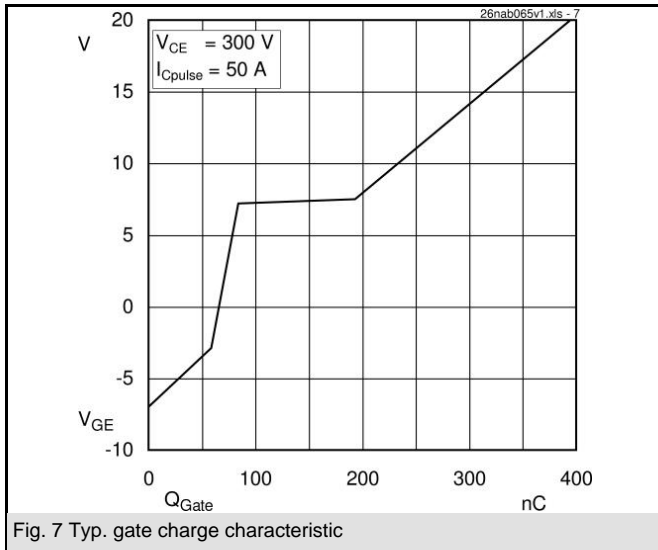
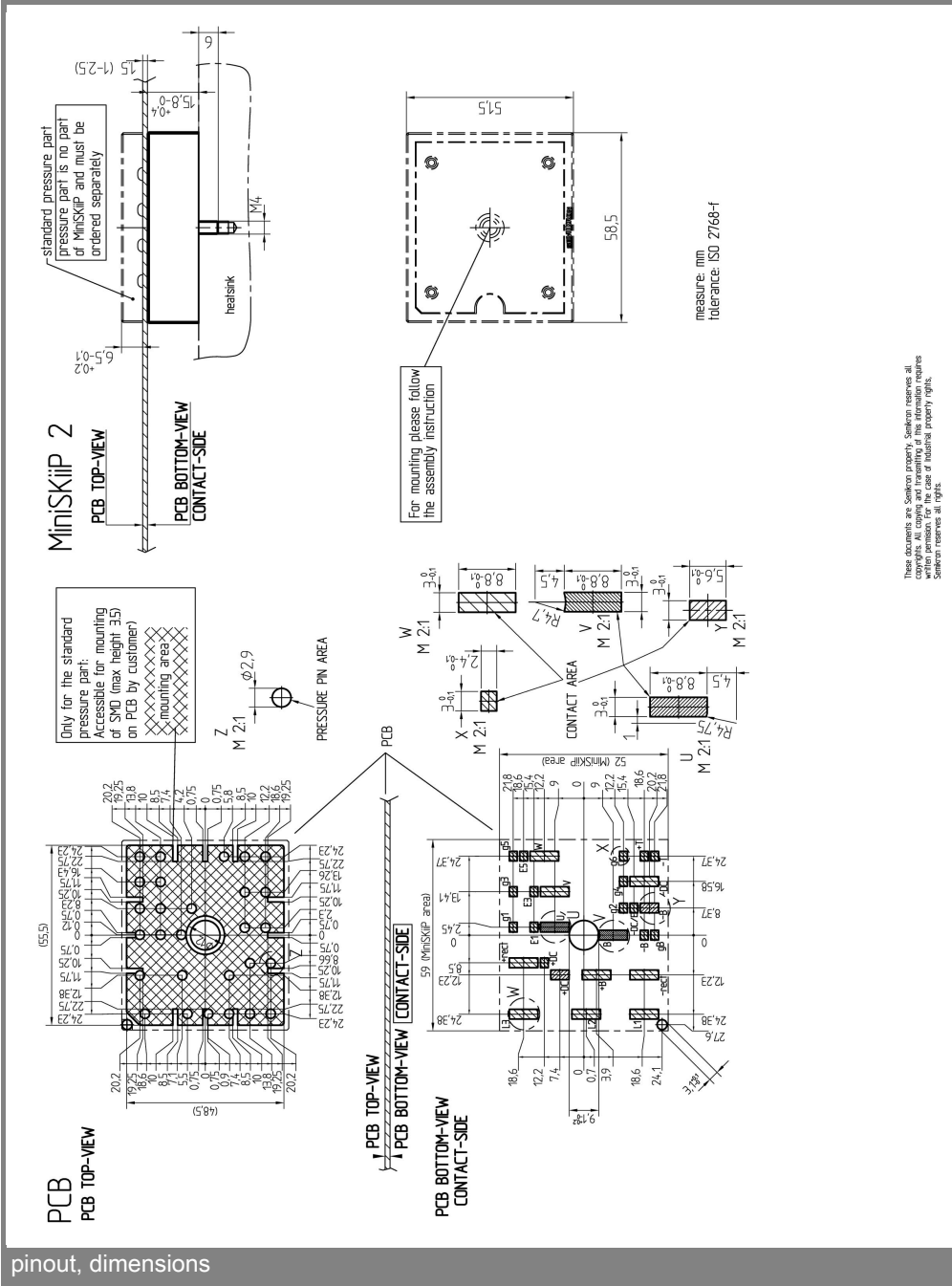
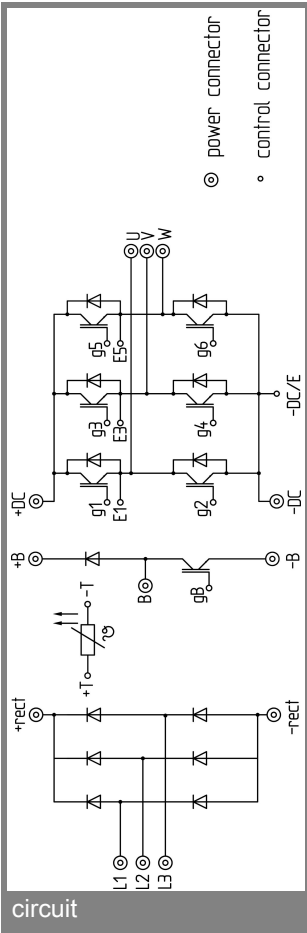

Fig. 6 Typ. Turn-on /-off energy = $f(R_G)$





This is an electrostatic discharge sensitive device (ESDS), international standard IEC 60747-1, Chapter IX.

This technical information specifies semiconductor devices but promises no characteristics. No warranty or guarantee expressed or implied is made regarding delivery, performance or suitability.