

# SKiIP 24NAB126V10

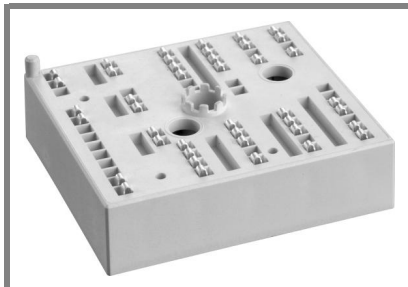

MiniSKiIP<sup>®</sup> 2

3-phase bridge rectifier +  
brake chopper + 3-phase  
bridge inverter  
**SKiIP 24NAB126V10**

## Features

- Fast Trench IGBTs
- Robust and soft freewheeling diodes in CAL technology
- Highly reliable spring contacts for electrical connections
- UL recognised file no. E63532

## Typical Applications

- Inverter up to 19 kVA
- Typical motor power 11 kW

## Remarks

- $V_{CEsat}$ ,  $V_F$  = chip level value

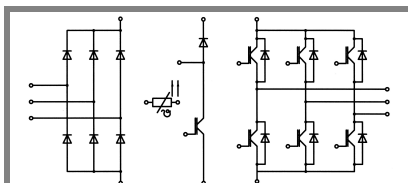

NAB

Absolute Maximum Ratings		$T_s = 25^\circ\text{C}$ , unless otherwise specified		
Symbol	Conditions	Values	Units	
<b>IGBT - Inverter, Chopper</b>				
$V_{CES}$	$T_s = 25 (70)^\circ\text{C}$	1200	V	
$I_C$		52 (40)	A	
$I_{CRM}$		70	A	
$V_{GES}$		$\pm 20$	V	
$T_j$		- 40 ... + 150	$^\circ\text{C}$	
<b>Diode - Inverter, Chopper</b>				
$I_F$	$T_s = 25 (70)^\circ\text{C}$	38 (29)	A	
$I_{FRM}$		70	A	
$T_j$		- 40 ... + 150	$^\circ\text{C}$	
<b>Diode - Rectifier</b>				
$V_{RRM}$	$T_s = 70^\circ\text{C}$	1600	V	
$I_F$		61	A	
$I_{FSM}$		$t_p = 10 \text{ ms, sin } 180^\circ, T_j = 25^\circ\text{C}$	700	A
$i^2t$		$t_p = 10 \text{ ms, sin } 180^\circ, T_j = 25^\circ\text{C}$	2400	$\text{A}^2\text{s}$
$T_j$		- 40 ... + 150	$^\circ\text{C}$	
<b>Module</b>				
$I_{RMS}$	per power terminal (20 A / spring)	40	A	
$T_{stg}$		- 40 ... + 125	$^\circ\text{C}$	
$V_{isol}$	AC, 1 min.	2500	V	

Characteristics		$T_s = 25^\circ\text{C}$ , unless otherwise specified			
Symbol	Conditions	min.	typ.	max.	Units
<b>IGBT - Inverter, Chopper</b>					
$V_{CEsat}$	$I_{Cnom} = 35 \text{ A}, T_j = 25 (125)^\circ\text{C}$		1,7 (2)	2,1 (2,4)	V
$V_{GE(th)}$	$V_{GE} = V_{CE}, I_C = 1,5 \text{ mA}$	5	5,8	6,5	V
$V_{CE(TO)}$	$T_j = 25 (125)^\circ\text{C}$		1 (0,9)	1,2 (1,1)	V
$r_T$	$T_j = 25 (125)^\circ\text{C}$		20 (31)	26 (37)	$\text{m}\Omega$
$C_{ies}$	$V_{CE} = 25 \text{ V}, V_{GE} = 0 \text{ V}, f = 1 \text{ MHz}$		2,4		nF
$C_{oes}$	$V_{CE} = 25 \text{ V}, V_{GE} = 0 \text{ V}, f = 1 \text{ MHz}$		0,5		nF
$C_{res}$	$V_{CE} = 25 \text{ V}, V_{GE} = 0 \text{ V}, f = 1 \text{ MHz}$		0,3		nF
$R_{th(j-s)}$	per IGBT		0,75		K/W
$t_{d(on)}$	under following conditions		80		ns
$t_r$	$V_{CC} = 600 \text{ V}, V_{GE} = \pm 15 \text{ V}$		30		ns
$t_{d(off)}$	$I_{Cnom} = 35 \text{ A}, T_j = 125^\circ\text{C}$		410		ns
$t_f$	$R_{Gon} = R_{Goff} = 15 \Omega$		120		ns
$E_{on}$	inductive load		4,6		mJ
$E_{off}$			4		mJ
<b>Diode - Inverter, Chopper</b>					
$V_F = V_{EC}$	$I_{Fnom} = 35 \text{ A}, T_j = 25 (125)^\circ\text{C}$		1,8 (1,8)	2,1 (2,2)	V
$V_{(TO)}$	$T_j = 25 (125)^\circ\text{C}$		1 (0,8)	1,1 (0,9)	V
$r_T$	$T_j = 25 (125)^\circ\text{C}$		23 (31)	29 (37)	$\text{m}\Omega$
$R_{th(j-s)}$	per diode		1,5		K/W
$I_{RRM}$	under following conditions		43		A
$Q_{rr}$	$I_{Fnom} = 35 \text{ A}, V_R = 600 \text{ V}$		7		$\mu\text{C}$
$E_{rr}$	$V_{GE} = 0 \text{ V}, T_j = 125^\circ\text{C}$ $di_F/dt = 1450 \text{ A}/\mu\text{s}$		3,3		mJ
<b>Diode -Rectifier</b>					
$V_F$	$I_{Fnom} = 35 \text{ A}, T_j = 25^\circ\text{C}$		1,1		V
$V_{(TO)}$	$T_j = 150^\circ\text{C}$		0,8		V
$r_T$	$T_j = 150^\circ\text{C}$		11		$\text{m}\Omega$
$R_{th(j-s)}$	per diode		0,9		K/W
<b>Temperature Sensor</b>					
$R_{ts}$	3 %, $T_r = 25 (100)^\circ\text{C}$		1000(1670)		$\Omega$
<b>Mechanical Data</b>					
w			65		g
$M_s$	Mounting torque	2		2,5	Nm

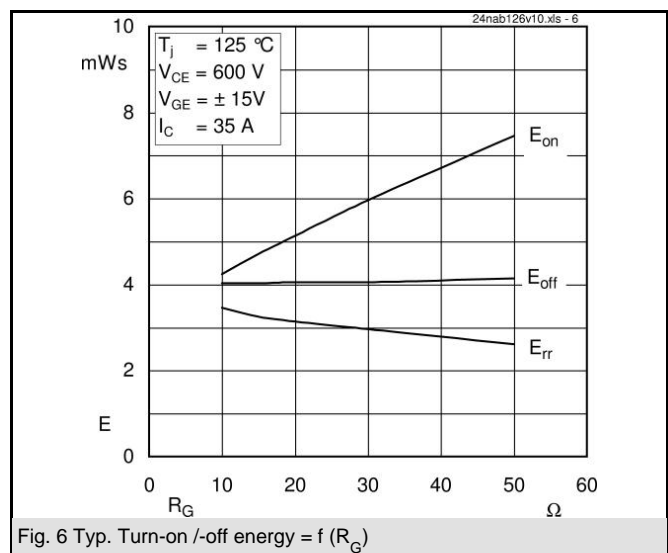
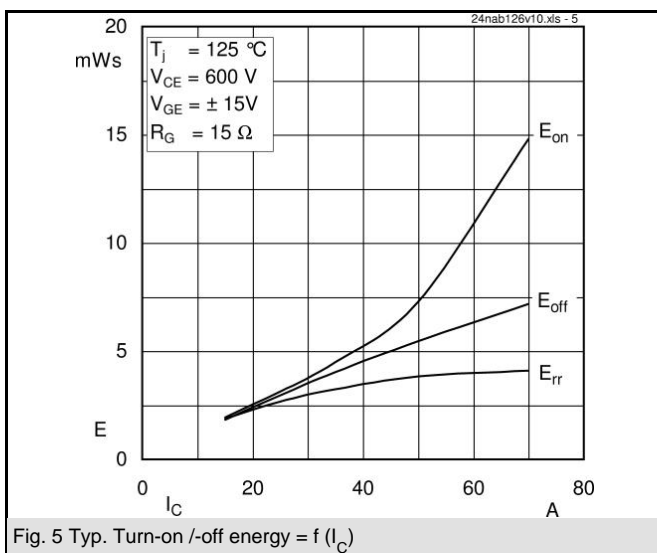
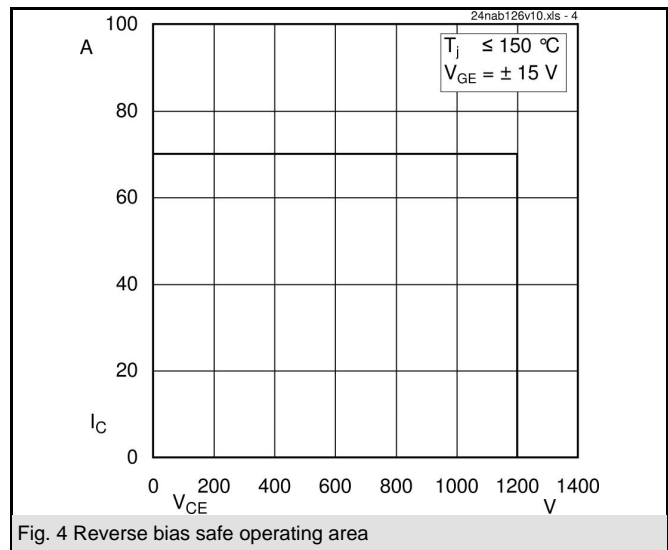
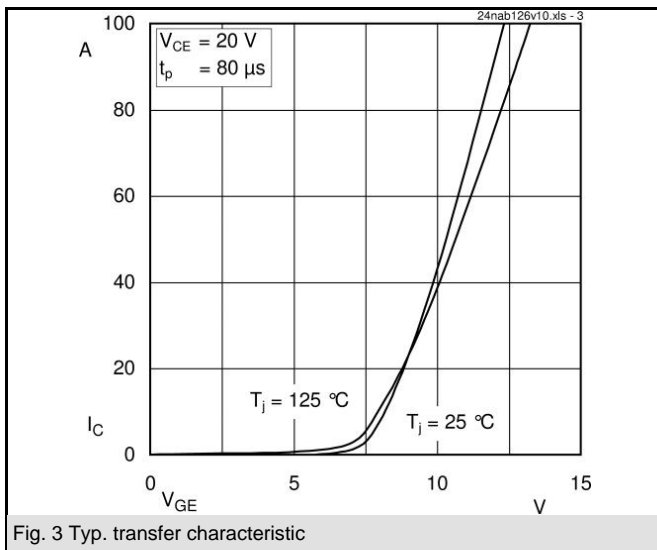
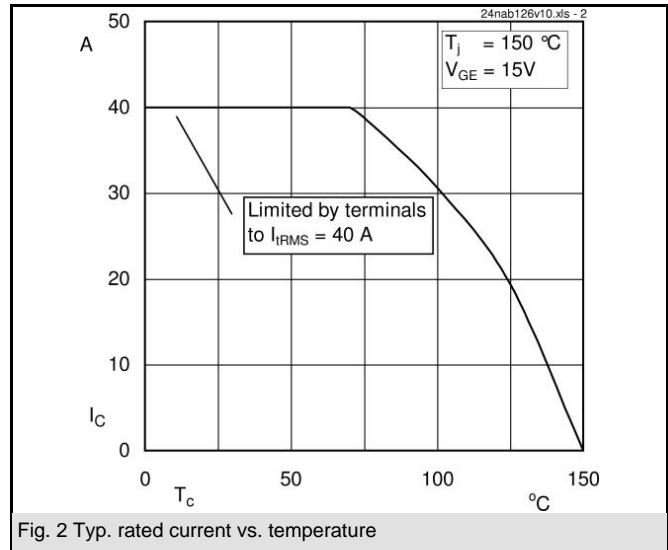
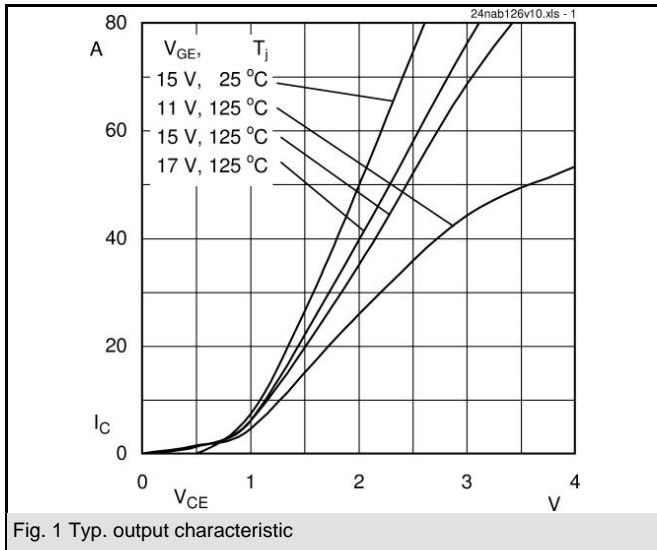

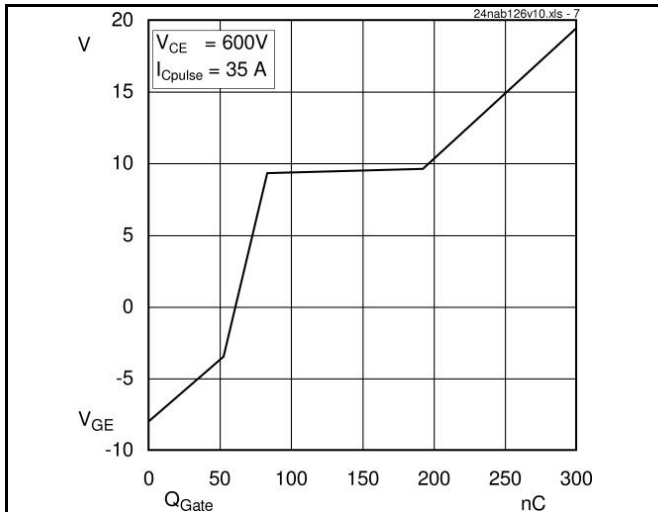

Fig. 7 Typ. gate charge characteristic

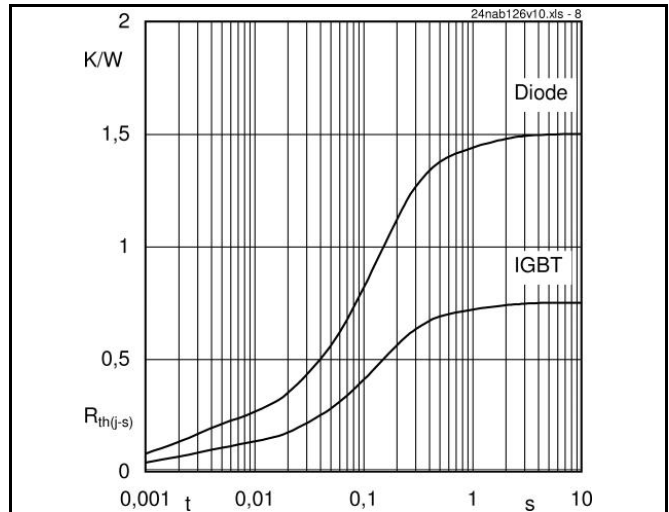

Fig. 8 Typ. thermal impedance

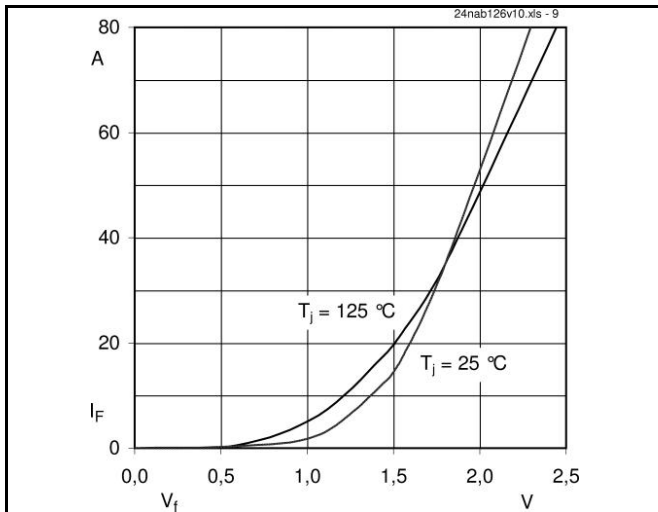

Fig. 9 Typ. freewheeling diode forward characteristic

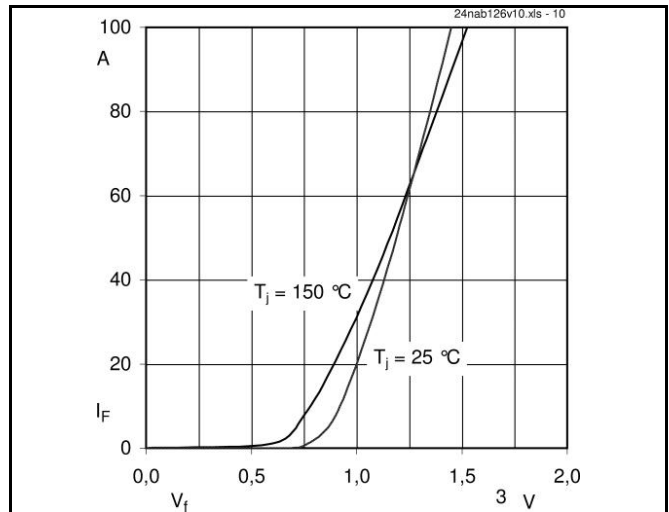
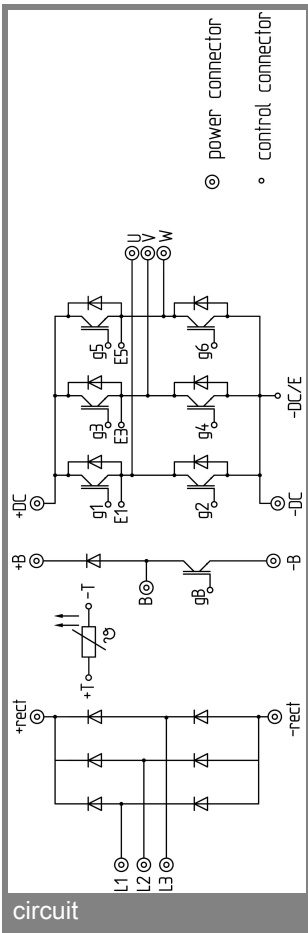
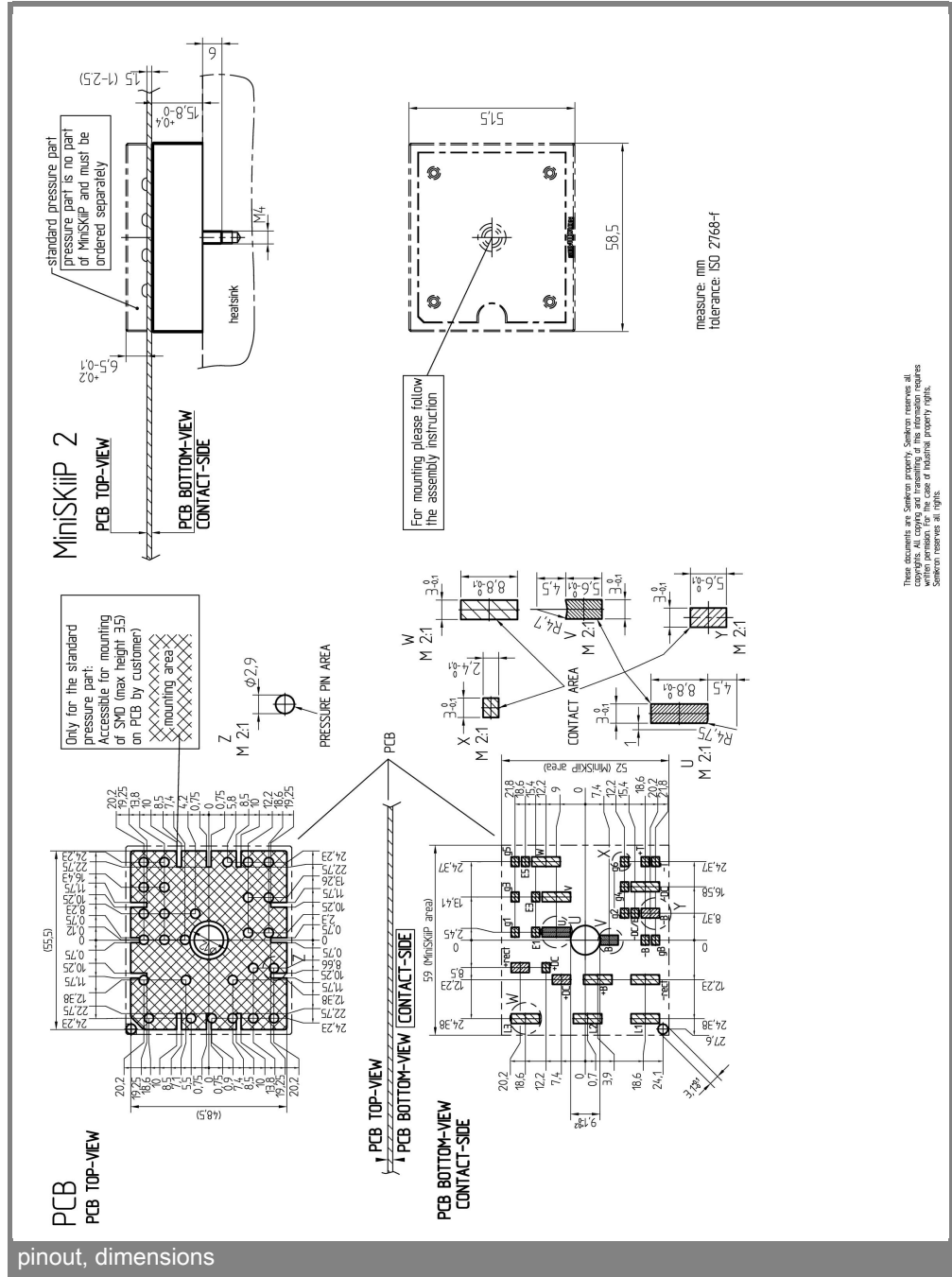

Fig. 10 Typ. input bridge forward characteristic

# SKiIP 24NAB126V10



circuit



pinout, dimensions

These documents are Cadsoft property. Cadsoft reserves all copyrights. All copying and translation of this information requires written permission. For the case of industrial property rights, SEMIKRON reserves all rights.