

# Am186™ ED/EDLV

## High Performance, 80C186- and 80C188-Compatible, 16-Bit Embedded Microcontrollers

### DISTINCTIVE CHARACTERISTICS

- **E86™ family 80C186- and 80C188-compatible microcontroller with enhanced bus interface**
  - Lower system cost with higher performance
  - 3.3-V ± 0.3-V operation (Am186EDLV microcontrollers)
- **Programmable DRAM Controller**
  - Supports zero-wait-state operation with 50-ns DRAM at 40 MHz, 60-ns @ 33 MHz, 70-ns @ 25 MHz
  - Includes programmable  $\overline{\text{CAS}}$ -before- $\overline{\text{RAS}}$  refresh capability
- **High performance**
  - 20-, 25-, 33-, and 40-MHz operating frequencies
  - Zero-wait-state operation at 40 MHz with 70-ns static memory
  - 1-Mbyte memory address space
  - 64-Kbyte I/O space
- **Enhanced features provide improved memory access and remove the requirement for a 2x clock input**
  - Nonmultiplexed address bus
  - Processor operates at the clock input frequency
  - 8-bit or 16-bit programmable bus sizing including 8-bit boot option
- **Enhanced integrated peripherals**
  - 32 programmable I/O (PIO) pins
  - Two full-featured asynchronous serial ports allow full-duplex, 7-bit, 8-bit, or 9-bit data transfers
- Serial port hardware handshaking with  $\overline{\text{CTS}}$ ,  $\overline{\text{RTS}}$ ,  $\overline{\text{ENRX}}$ , and  $\overline{\text{RTR}}$  selectable for each port
- Improved serial port operation enhances 9-bit DMA support
- Independent serial port baud rate generators
- DMA to and from the serial ports
- Watchdog timer can generate NMI or reset
- A pulse-width demodulation option
- A data strobe, true asynchronous bus interface option included for  $\overline{\text{DEN}}$
- Reset configuration register
- **Familiar 80C186 peripherals**
  - Two independent DMA channels
  - Programmable interrupt controller with up to 8 external and 8 internal interrupts
  - Three programmable 16-bit timers
  - Programmable memory and peripheral chip-select logic
  - Programmable wait state generator
  - Power-save clock divider
- **Software-compatible with the 80C186 and 80C188 microcontrollers with widely available native development tools, applications, and system software**
- **A compatible evolution of the Am186EM, Am186ES, and Am186ER microcontrollers**
- **Available in the following packages:**
  - 100-pin, thin quad flat pack (TQFP)
  - 100-pin, plastic quad flat pack (PQFP)

### GENERAL DESCRIPTION

The Am186™ ED/EDLV microcontrollers are part of the AMD E86™ family of embedded microcontrollers and microprocessors based on the x86 architecture. The Am186ED/EDLV microcontrollers are the ideal upgrade for 80C186/188 designs requiring 80C186/188 compatibility, increased performance, serial communications, a direct bus interface, and more than 64K of memory.

The Am186ED/EDLV microcontrollers integrate a complete DRAM controller to take advantage of low DRAM costs. This reduces memory subsystem costs while maintaining SRAM performance. The Am186ED/EDLV microcontrollers also integrate the functions of a CPU, nonmultiplexed address bus, three timers, watchdog timer, chip selects, interrupt controller, two DMA controllers, two asynchronous serial ports, programmable bus

sizing, and programmable I/O (PIO) pins on one chip. Compared to the 80C186/188 microcontrollers, the Am186ED/EDLV microcontrollers enable designers to reduce the size, power consumption, and cost of embedded systems, while increasing reliability, functionality, and performance.

The Am186ED/EDLV microcontrollers have been designed to meet the most common requirements of embedded products developed for the communications, office automation, mass storage, and general embedded markets. Specific applications include PBXs, multiplexers, modems, disk drives, hand-held and desktop terminals, fax machines, printers, photocopiers, and industrial controls.

Am186ED/EDLV MICROCONTROLLERS BLOCK DIAGRAM

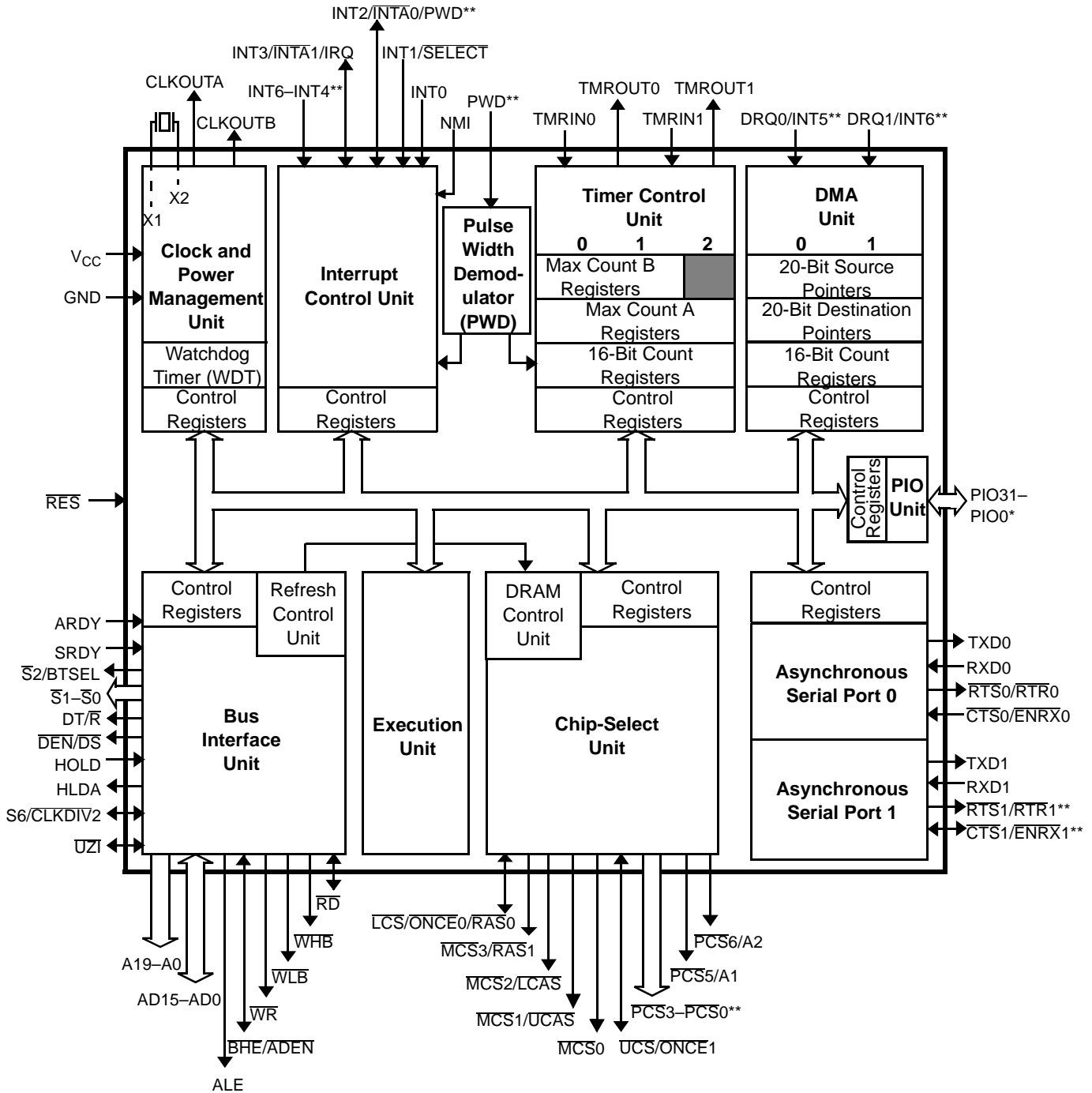

Notes:

\*All PIO signals are shared with other physical pins. See the pin descriptions beginning on page 21 and Table 2 on page 29 for information on shared functions.

\*\* RTS1/RTR1 and CTS1/ENRX1 are multiplexed with PCS3 and PCS2, respectively. See the pin descriptions beginning on page 21.

## ORDERING INFORMATION

### Standard Products

AMD standard products are available in several packages and operating ranges. The order number (valid combination) is formed by a combination of the elements below.

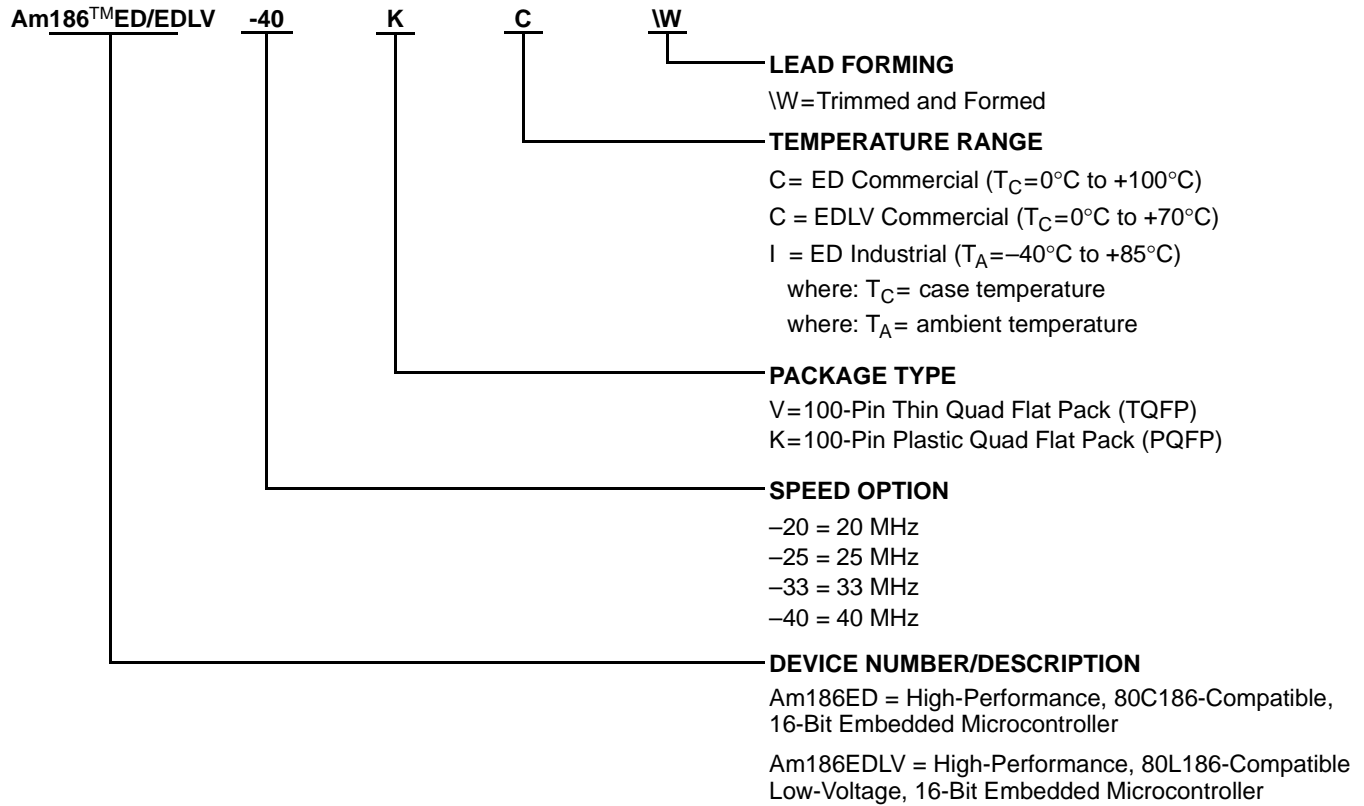

Valid Combinations	
Am186ED-20 Am186ED-25 Am186ED-33 Am186ED-40	VC\W or KC\W
Am186ED-20 Am186ED-25	K\W <sup>1</sup>
Am186EDLV-20 Am186EDLV-25	VC\W or KC\W

**Note:**  
 The industrial version of the Am186ED is offered only in the PQFP package.

#### Valid Combinations

Valid combinations list configurations planned to be supported in volume for this device. Consult the local AMD sales office to confirm availability of specific valid combinations and to check on newly released combinations.

**Note:** The industrial version of the Am186ED as well as the Am186EDLV are available in 20 and 25 MHz operating frequencies only.

The Am186ED and Am186EDLV microcontrollers are all functionally the same except for their DC characteristics and available frequencies.

**Note:** There is no 188 version of the Am186ED/EDLV. The same 8-bit external bus capabilities can be achieved using the 8-bit boot capability and programmable bus sizing options.

## TABLE OF CONTENTS

DISTINCTIVE CHARACTERISTICS .....	1
GENERAL DESCRIPTION .....	1
AM186ED/EDLV MICROCONTROLLERS BLOCK DIAGRAM .....	2
ORDERING INFORMATION .....	3
Standard Products .....	3
RELATED AMD PRODUCTS .....	9
E86™ Family Devices .....	9
Related Documents .....	10
Third-Party Development Support Products .....	10
Customer Service .....	10
KEY FEATURES AND BENEFITS .....	10
Application Considerations .....	11
COMPARING THE AM186ED/EDLV TO THE AM186ES/ESLV MICROCONTROLLERS .....	12
Integrated DRAM Controller .....	12
Enhanced Refresh Control Unit .....	13
Option to Overlap DRAM with PCS .....	13
Additional Serial Port Mode for DMA Support of 9-bit Protocols .....	13
Option to Boot from 8- or 16-bit Memory .....	13
Improved External Bus Master Support .....	13
PSRAM Controller Removed .....	13
TQFP CONNECTION DIAGRAMS AND PINOUTS .....	14
Top Side View—100-Pin Thin Quad Flat Pack (TQFP) .....	14
TQFP PIN DESIGNATIONS .....	15
Sorted by Pin Number .....	15
Sorted by Pin Name .....	16
PQFP CONNECTION DIAGRAMS AND PINOUTS .....	17
Top Side View—100-Pin Plastic Quad Flat Pack (PQFP) .....	17
PQFP PIN DESIGNATIONS .....	18
Sorted by Pin Number .....	18
Sorted by Pin Name .....	19
LOGIC SYMBOL—AM186ED/EDLV MICROCONTROLLERS .....	20
PIN DESCRIPTIONS .....	21
Pins That Are Used by Emulators .....	21
Pin Terminology .....	21
A19–A0 (A19/PIO9, A18/PIO8, A17/PIO7) .....	21
AD15–AD8 .....	21
AD7–AD0 .....	21
ALE .....	21
ARDY .....	22
BHE/ADEN .....	22
CLKOUTA .....	22
CLKOUTB .....	22
CTS0/ENRX0/PIO21 .....	22
DEN/DS/PIO5 .....	23
DRQ0/INT5/PIO12 .....	23
DRQ1/INT6/PIO13 .....	23
DT/R/PIO4 .....	23
GND .....	23
HLDA .....	23
HOLD .....	23
INT0 .....	24
INT1/SELECT .....	24

INT2/ $\overline{\text{INTA}}0$ /PWD/PIO31 .....	24
INT3/ $\overline{\text{INTA}}1$ /IRQ .....	24
INT4/PIO30 .....	25
$\overline{\text{LCS}}$ / $\overline{\text{ONCE}}0$ / $\overline{\text{RAS}}0$ .....	25
$\overline{\text{MCS}}0$ /PIO14 .....	25
$\overline{\text{MCS}}1$ / $\overline{\text{UCAS}}$ /PIO15 .....	25
$\overline{\text{MCS}}2$ / $\overline{\text{LCAS}}$ /PIO24 .....	25
$\overline{\text{MCS}}3$ / $\overline{\text{RAS}}1$ /PIO25 .....	26
NMI .....	26
$\overline{\text{PCS}}1$ /PIO17, $\overline{\text{PCS}}0$ /PIO16 .....	26
$\overline{\text{PCS}}2$ / $\overline{\text{CTS}}1$ / $\overline{\text{ENRX}}1$ /PIO18 .....	27
$\overline{\text{PCS}}3$ / $\overline{\text{RTS}}1$ / $\overline{\text{RTR}}1$ /PIO19 .....	27
$\overline{\text{PCS}}5$ /A1/PIO3 .....	27
$\overline{\text{PCS}}6$ /A2/PIO2 .....	28
PIO31–PIO0 (Shared) .....	28
$\overline{\text{RD}}$ .....	28
$\overline{\text{RES}}$ .....	28
$\overline{\text{RTS}}0$ / $\overline{\text{RTR}}0$ /PIO20 .....	30
RXD0/PIO23 .....	30
RXD1/PIO28 .....	30
$\overline{\text{S}}2$ /BTSEL .....	30
$\overline{\text{S}}1$ – $\overline{\text{S}}0$ .....	30
S6/ $\overline{\text{CLKDIV}}2$ /PIO29 .....	30
SRDY/PIO6 .....	30
TMRIN0/PIO11 .....	31
TMRIN1/PIO0 .....	31
TMROUT0/PIO10 .....	31
TMROUT1/PIO1 .....	31
TXD0/PIO22 .....	31
TXD1/PIO27 .....	31
$\overline{\text{UCS}}$ / $\overline{\text{ONCE}}1$ .....	31
$\overline{\text{UZI}}$ /PIO26 .....	31
$V_{\text{CC}}$ .....	31
$\overline{\text{WHB}}$ .....	31
$\overline{\text{WLB}}$ .....	32
$\overline{\text{WR}}$ .....	32
X1 .....	32
X2 .....	32
FUNCTIONAL DESCRIPTION .....	33
Memory Organization .....	33
I/O Space .....	33
BUS OPERATION .....	34
BUS INTERFACE UNIT .....	36
Nonmultiplexed Address Bus .....	36
DRAM Address Multiplexing .....	36
Programmable Bus Sizing .....	37
Byte-Write Enables .....	37
Data Strobe Bus Interface Option .....	37
DRAM INTERFACE .....	37
PERIPHERAL CONTROL BLOCK .....	38
Reading and Writing the PCB .....	38

CLOCK AND POWER MANAGEMENT .....	40
Phase-Locked Loop .....	40
Crystal-Driven Clock Source .....	40
External Source Clock .....	41
System Clocks .....	41
Power-Save Operation .....	41
Initialization and Processor Reset .....	41
Reset Configuration Register .....	41
CHIP-SELECT UNIT .....	42
Chip-Select Timing .....	42
Ready and Wait-State Programming .....	42
Chip-Select Overlap .....	42
Upper Memory Chip Select .....	43
Low Memory Chip Select .....	43
Midrange Memory Chip Selects .....	43
Peripheral Chip Selects .....	43
REFRESH CONTROL UNIT .....	44
INTERRUPT CONTROL UNIT .....	44
TIMER CONTROL UNIT .....	45
Watchdog Timer .....	45
PULSE WIDTH DEMODULATION .....	45
DIRECT MEMORY ACCESS .....	46
DMA Operation .....	46
DMA Channel Control Registers .....	47
DMA Priority .....	47
ASYNCHRONOUS SERIAL PORTS .....	47
DMA Transfers through the Serial Port .....	48
PROGRAMMABLE I/O (PIO) PINS .....	48
ABSOLUTE MAXIMUM RATINGS .....	49
OPERATING RANGES .....	49
DC CHARACTERISTICS OVER COMMERCIAL AND INDUSTRIAL OPERATING RANGES ..	49
CAPACITANCE .....	50
POWER SUPPLY CURRENT .....	50
THERMAL CHARACTERISTICS .....	51
TQFP Package .....	51
Typical Ambient Temperatures .....	52
COMMERCIAL AND INDUSTRIAL SWITCHING CHARACTERISTICS AND WAVEFORMS ..	57
Key to Switching Waveforms .....	57
Alphabetical Key to Switching Parameter Symbols .....	58
Numerical Key to Switching Parameter Symbols .....	61
SWITCHING CHARACTERISTICS OVER COMMERCIAL AND INDUSTRIAL	
OPERATING RANGES .....	64
Read Cycle (20 MHz and 25 MHz) .....	64
SWITCHING CHARACTERISTICS OVER COMMERCIAL OPERATING RANGES .....	65
Read Cycle (33 MHz and 40 MHz) .....	65
READ CYCLE WAVEFORMS .....	66
SWITCHING CHARACTERISTICS OVER COMMERCIAL AND INDUSTRIAL	
OPERATING RANGES .....	67
Write Cycle (20 MHz and 25 MHz) .....	67
SWITCHING CHARACTERISTICS OVER COMMERCIAL OPERATING RANGES .....	68
Write Cycle (33 MHz and 40 MHz) .....	68
WRITE CYCLE WAVEFORMS .....	69

SWITCHING CHARACTERISTICS OVER COMMERCIAL AND INDUSTRIAL	
OPERATING RANGES .....	70
DRAM .....	70
DRAM Read Cycle Timing with No-Wait States .....	71
DRAM Read Cycle Timing with Wait State(s) .....	71
DRAM Write Cycle Timing with No-Wait States .....	72
DRAM Write Cycle Timing With Wait State(s) .....	72
DRAM $\overline{\text{CAS}}$ -before- $\overline{\text{RAS}}$ Cycle Timing .....	73
SWITCHING CHARACTERISTICS OVER COMMERCIAL AND INDUSTRIAL	
OPERATING RANGES .....	74
Interrupt Acknowledge Cycle (20 MHz and 25 MHz) .....	74
SWITCHING CHARACTERISTICS OVER COMMERCIAL OPERATING RANGES .....	75
Interrupt Acknowledge Cycle (33 MHz and 40 MHz) .....	75
INTERRUPT ACKNOWLEDGE CYCLE WAVEFORMS .....	76
SWITCHING CHARACTERISTICS OVER COMMERCIAL AND INDUSTRIAL	
OPERATING RANGES .....	77
Software Halt Cycle (20 MHz and 25 MHz) .....	77
SWITCHING CHARACTERISTICS OVER COMMERCIAL OPERATING RANGES .....	77
Software Halt Cycle (33 MHz and 40 MHz) .....	77
SOFTWARE HALT CYCLE WAVEFORMS .....	78
SWITCHING CHARACTERISTICS OVER COMMERCIAL AND INDUSTRIAL	
OPERATING RANGES .....	79
Clock (20 MHz and 25 MHz) .....	79
SWITCHING CHARACTERISTICS OVER COMMERCIAL OPERATING RANGES .....	80
Clock (33 MHz and 40 MHz) .....	80
CLOCK WAVEFORMS .....	81
Clock Waveforms—Active Mode .....	81
Clock Waveforms—Power-Save Mode .....	81
SWITCHING CHARACTERISTICS OVER COMMERCIAL AND INDUSTRIAL	
OPERATING RANGES .....	82
Ready and Peripheral (20 MHz and 25 MHz) .....	82
SWITCHING CHARACTERISTICS OVER COMMERCIAL OPERATING RANGES .....	82
Ready and Peripheral (33 MHz and 40 MHz) .....	82
SYNCHRONOUS, ASYNCHRONOUS, AND PERIPHERAL WAVEFORMS .....	83
Synchronous Ready Waveforms .....	83
Asynchronous Ready Waveforms .....	83
Peripheral Waveforms .....	83
SWITCHING CHARACTERISTICS OVER COMMERCIAL AND INDUSTRIAL	
OPERATING RANGES .....	84
Reset and Bus Hold (20 MHz and 25 MHz) .....	84
SWITCHING CHARACTERISTICS OVER COMMERCIAL OPERATING RANGES .....	84
Reset and Bus Hold (33 MHz and 40 MHz) .....	84
RESET AND BUS HOLD WAVEFORMS .....	85
Reset Waveforms .....	85
Signals Related to Reset Waveforms .....	85
Bus Hold Waveforms—Entering .....	86
Bus Hold Waveforms—Leaving .....	86
TQFP PHYSICAL DIMENSIONS .....	87
PQFP PHYSICAL DIMENSIONS .....	88



**LIST OF FIGURES**

Figure 1	Am186ED Microcontroller Example System Design .....	11
Figure 2	80C186 Microcontroller Example System Design .....	12
Figure 3	Two-Component Address .....	33
Figure 4	16-Bit Mode—Normal Read and Write Operation .....	34
Figure 5	16-Bit Mode—Read and Write with Address Bus Disable In Effect .....	35
Figure 6	8-Bit Mode—Normal Read and Write Operation .....	35
Figure 7	8-Bit Mode—Read and Write with Address Bus Disable in Effect .....	36
Figure 8	Am186ED/EDLV Microcontrollers Oscillator Configurations .....	40
Figure 9	Clock Organization .....	41
Figure 10	DMA Unit Block Diagram .....	47
Figure 11	Typical $I_{CC}$ Versus Frequency for Am186EDLV Microcontroller .....	50
Figure 12	Typical $I_{CC}$ Versus Frequency for Am186ED Microcontroller .....	50
Figure 13	Thermal Resistance ( $^{\circ}\text{C}/\text{Watt}$ ) .....	51
Figure 14	Thermal Characteristics Equations .....	51
Figure 15	Typical Ambient Temperatures for PQFP with a 2-Layer Board .....	53
Figure 16	Typical Ambient Temperatures for TQFP with a 2-Layer Board .....	54
Figure 17	Typical Ambient Temperatures for PQFP with a 4-Layer to 6-Layer Board .....	55
Figure 18	Typical Ambient Temperatures for TQFP with a 4-Layer to 6-Layer Board .....	56

**LIST OF TABLES**

Table 1	Data Byte Encoding .....	22
Table 2	Numeric PIO Pin Designations .....	29
Table 3	Alphabetic PIO Pin Designations .....	29
Table 4	Bus Cycle Encoding .....	30
Table 5	Segment Register Selection Rules .....	33
Table 6	DRAM Pin Interface .....	37
Table 7	Programming the Bus Width of Am186ED/EDLV Microcontrollers .....	37
Table 8	Peripheral Control Block Register Map .....	39
Table 9	Am186ED/EDLV Microcontrollers Maximum DMA Transfer Rates .....	46
Table 10	Typical Power Consumption Calculation for the Am186EDLV Microcontroller .....	50
Table 11	Thermal Characteristics ( $^{\circ}\text{C}/\text{Watt}$ ) .....	51
Table 12	Typical Power Consumption Calculation .....	52
Table 13	Junction Temperature Calculation .....	52
Table 14	Typical Ambient Temperatures ( $^{\circ}\text{C}$ ) for PQFP with a 2-Layer Board .....	53
Table 15	Typical Ambient Temperatures ( $^{\circ}\text{C}$ ) for TQFP with a 2-Layer Board .....	54
Table 16	Typical Ambient Temperatures ( $^{\circ}\text{C}$ ) for PQFP with a 4-Layer to 6-Layer Board ...	55
Table 17	Typical Ambient Temperatures ( $^{\circ}\text{C}$ ) for TQFP with a 4-Layer to 6-Layer Board ...	56



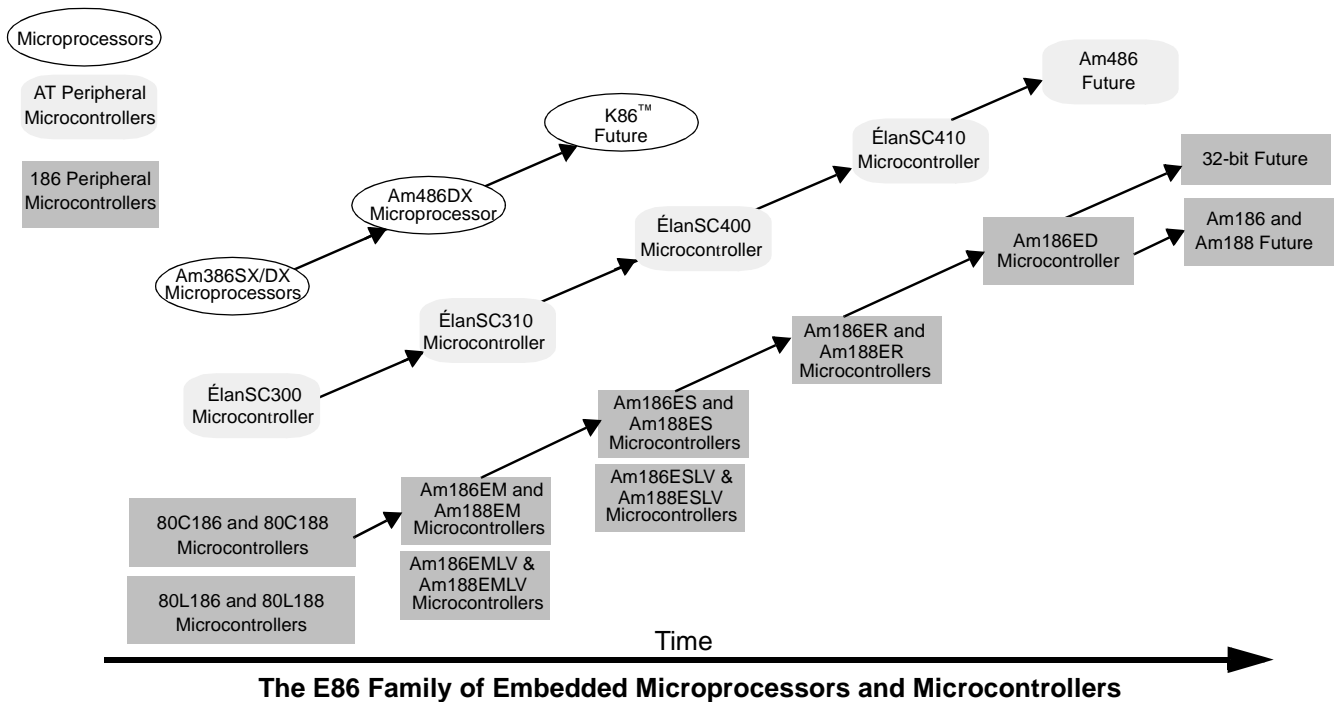

## RELATED AMD PRODUCTS

### E86™ Family Devices

Device	Description
80C186	16-bit microcontroller
80C188	16-bit microcontroller with 8-bit external data bus
80L186	Low-voltage, 16-bit microcontroller
80L188	Low-voltage, 16-bit microcontroller with 8-bit external data bus
Am186EM	High-performance, 80C186-compatible, 16-bit embedded microcontroller
Am188EM	High-performance, 80C188-compatible, 16-bit embedded microcontroller with 8-bit external data bus
Am186EMLV	High-performance, 80C186-compatible, low-voltage, 16-bit embedded microcontroller
Am188EMLV	High-performance, 80C188-compatible, low-voltage, 16-bit embedded microcontroller with 8-bit external data bus
Am186ES	High-performance, 80C186-compatible, 16-bit embedded microcontroller
Am188ES	High-performance, 80C188-compatible, 16-bit embedded microcontroller with 8-bit external data bus
Am186ESLV	High-performance, 80C186-compatible, low-voltage, 16-bit embedded microcontroller
Am188ESLV	High-performance, 80C188-compatible, low-voltage, 16-bit embedded microcontroller with 8-bit external data bus
Am186ED	High-performance, 80C186- and 80C188-compatible, 16-bit embedded microcontroller with 8- or 16-bit external data bus
Am186EDLV	High-performance, 80C186- and 80C188-compatible, low-voltage, 16-bit embedded microcontroller with 8- or 16-bit external data bus
Am186ER	High-performance, 80C186-compatible, low-voltage, 16-bit embedded microcontroller with 32 Kbyte of internal RAM
Am188ER	High-performance, 80C188-compatible, low-voltage, 16-bit embedded microcontroller with 8-bit external data bus and 32 Kbyte of internal RAM
Élan™ SC300	High-performance, highly integrated, low-voltage, 32-bit embedded microcontroller
ÉlanSC310	High-performance, single-chip, 32-bit embedded PC/AT microcontroller
ÉlanSC400	Single-chip, low-power, PC/AT-compatible microcontroller
ÉlanSC410	Single-chip, PC/AT-compatible microcontroller
Am386@DX	High-performance, 32-bit embedded microprocessor with 32-bit external data bus
Am386@SX	High-performance, 32-bit embedded microprocessor with 16-bit external data bus
Am486@DX	High-performance, 32-bit embedded microprocessor with 32-bit external data bus

## Related Documents

The following documents provide additional information regarding the Am186ED/EDLV microcontrollers:

- *Am186ED/EDLV Microcontrollers User's Manual*, order # 21335
- *Am186 and Am188 Family Instruction Set Manual*, order # 21267
- *FusionE86<sup>SM</sup> Catalog*, order # 19255
- *E86 Family Support Tools Brief*, order # 20071
- FusionE86 Development Tools Reference CD, order # 21058

## Third-Party Development Support Products

The FusionE86<sup>SM</sup> Program of Partnerships for Application Solutions provides the customer with an array of products designed to meet critical time-to-market needs. Products and solutions available from the AMD FusionE86 partners include emulators, hardware and software debuggers, board-level products, and software development tools, among others.

In addition, mature development tools and applications for the x86 platform are widely available in the general marketplace.

## Customer Service

The AMD customer service network includes U.S. offices, international offices, and a customer training center. Expert technical assistance is available from the worldwide staff of AMD field application engineers and factory support staff to answer E86 family hardware and software development questions.

### Hotline and World Wide Web Support

For answers to technical questions, AMD provides a toll-free number for direct access to our corporate applications hotline. Also available is the AMD World Wide Web home page and FTP site, which provides the latest E86 family product information, including technical information and data on upcoming product releases.

**For technical support questions on all E86 products, send E-mail to [lpd.support@amd.com](mailto:lpd.support@amd.com).**

### Corporate Applications Hotline

(800) 222-9323 Toll-free for U.S. and Canada

44-(0) 1276-803-299 U.K. and Europe hotline

### World Wide Web Home Page and FTP Site

To access the AMD home page go to:  
<http://www.amd.com>.

To download documents and software, ftp to <ftp://ftp.amd.com> and log on as anonymous using your E-mail address as a password. Or via your web browser, go to <ftp://ftp.amd.com>.

Questions, requests, and input concerning AMD's WWW pages can be sent via E-mail to [webmaster@amd.com](mailto:webmaster@amd.com).

## Documentation and Literature

Free E86 family information such as data books, user's manuals, data sheets, application notes, the FusionE86 Partner Solutions Catalog, and other literature is available with a simple phone call. Internationally, contact your local AMD sales office for complete E86 family literature.

### Literature Ordering

(800) 222-9323	Toll-free for U.S. and Canada
(512) 602-5651	Direct dial worldwide
(512) 602-7639	fax
(800) 222-9323	AMD Facts-On-Demand™ fax information service, toll-free for U.S. and Canada

## KEY FEATURES AND BENEFITS

The Am186ED/EDLV microcontrollers extend the AMD family of microcontrollers based on the industry-standard x86 architecture. The Am186ED/EDLV microcontrollers are a higher-performance, highly integrated version of the 80C186/188 microprocessors, offering an attractive migration path. In addition, the Am186ED/EDLV microcontrollers offer application-specific features that can enhance the system functionality of the Am186ES/ESLV and Am188ES/ESLV microcontrollers. Upgrading to the Am186ED/EDLV microcontrollers is an attractive solution for several reasons:

- **Programmable DRAM controller**—Enables system designers to take advantage of low-cost DRAM and fully utilize the performance and flexibility of the x86 architecture. The DRAM controller supports zero wait-state performance with 50-ns DRAM at 40 MHz, or, if required, can be programmed with wait states. The Am186ED/EDLV microcontrollers provide a  $\overline{\text{CAS}}$ -before- $\overline{\text{RAS}}$  refresh unit.
- **Minimized total system cost**—New and enhanced peripherals and on-chip system interface logic on the Am186ED/EDLV microcontrollers reduce the cost of existing 80C186/188 designs.
- **X86 software compatibility**—80C186/188-compatible and upward-compatible with the other members of the AMD E86 family.

- **Enhanced performance**—The Am186ED/EDLV microcontrollers increase the performance of 80C186/188 systems, and the nonmultiplexed address bus offers unbuffered access to memory.
- **Enhanced functionality**—The enhanced on-chip peripherals of the Am186ED/EDLV microcontrollers include two asynchronous serial ports, 32 PIOs, a watchdog timer, additional interrupt pins, a pulse width demodulation option, DMA directly to and from the serial ports, 8-bit and 16-bit programmable bus sizing, a 16-bit reset configuration register, and enhanced chip-select functionality.

## Application Considerations

The integration enhancements of the Am186ED/EDLV microcontrollers provide a high-performance, low-system-cost solution for 16-bit embedded microcontroller designs. The nonmultiplexed address bus eliminates the need for system-support logic to interface memory devices, while the multiplexed address/data bus maintains the value of previously engineered, customer-specific peripherals and circuits within the upgraded design.

Figure 1 illustrates an example system design that uses the integrated peripheral set to achieve high performance with reduced system cost.

### Memory Interface

The Am186ED/EDLV microcontrollers integrate a versatile memory controller which supports direct memory accesses to DRAM, SRAM, Flash, EPROM, and ROM. No external glue logic is required and all required control signals are provided. The peripheral chip selects have been enhanced to allow them to overlap the DRAM. This allows a small 1.5K portion of the DRAM memory space to be used for peripherals without bus contention.

The improved memory timing specifications of the Am186ED/EDLV microcontrollers allow for zero-wait-state operation at 40 MHz using 50-ns DRAM, 70-ns SRAM, or 70-ns Flash memory. For 60-ns DRAM one wait state is required at 40 MHz and zero wait states at 33 MHz and below. For 70-ns DRAM two wait states are required at 40 MHz, one wait state at 33 MHz, and zero wait states at 25 MHz and below. This reduces overall system cost by enabling the use of commonly available memory speeds and taking advantage of DRAM's lower cost per bit over SRAM.

Figure 1 also shows an implementation of an RS-232 console or modem communications port. The RS-232 to CMOS voltage-level converter is required for the electrical interface with the external device.

## Clock Generation

The integrated clock generation circuitry of the Am186ED/EDLV microcontrollers enables the use of a 1x crystal frequency. The Am186ED design in Figure 1 achieves 40-MHz CPU operation, while using a 40-MHz crystal.

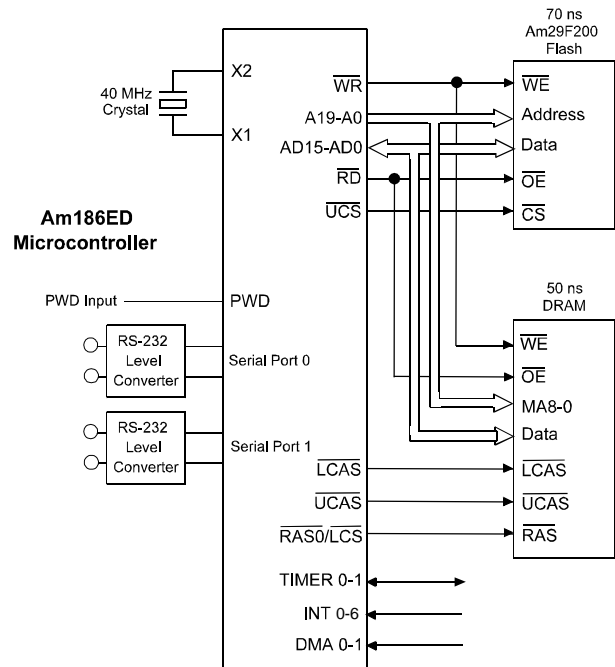

**Figure 1. Am186ED Microcontroller Example System Design**

### Direct Memory Interface Example

Figure 1 illustrates the direct memory interface of the Am186ED microcontroller. The processor's A19–A0 bus connects to the memory address inputs, the AD bus connects to the data inputs and outputs, and the chip selects connect to the memory chip-select inputs. The odd A1–A17 address pins connect to the DRAM multiplexed address bus.

The  $\overline{RD}$  output connects to the DRAM Output Enable ( $\overline{OE}$ ) pin for read operations. Write operations use the  $\overline{WR}$  output connected to the DRAM Write Enable ( $\overline{WE}$ ) pin. The  $\overline{UCAS}$  and  $\overline{LCAS}$  pins provide byte selection.

**COMPARING THE Am186ES/ESLV TO THE Am186ED/EDLV MICROCONTROLLERS**

Compared to the Am186ES/ESLV microcontrollers, the Am186ED/EDLV microcontrollers have the following additional features:

- Integrated DRAM controller
- Enhanced refresh control unit
- Option to overlap DRAM with peripheral chip select (PCS)
- Additional serial port mode for DMA support of 9-bit protocols
- Option to boot from 8- or 16-bit memory
- Improved external bus master support
- PSRAM controller removed

Figure 1 shows an example system using a 40-MHz Am186ED microcontroller. Figure 2 shows a comparable system implementation with an 80C186. Because of its superior integration, the Am186ED/EDLV system does not require the support devices that are required on the 80C186 example system. In addition, the Am186ED/EDLV microcontrollers provide

significantly better performance with its 40-MHz clock rate.

**Integrated DRAM Controller**

The integrated DRAM controller directly interfaces DRAM to support no-wait state DRAM interface up to 40 MHz. Wait states can be inserted to support slower DRAM. All signals required by the DRAM are generated on the Am186ED/EDLV microcontrollers and no external logic is required. The DRAM multiplexed address pins are connected to the odd address pins starting with A1 on the Am186ED/EDLV microcontrollers to MA0 on the DRAM. The correct row and column addresses are generated on these pins during a DRAM access. The  $\overline{UCAS}$  and  $\overline{LCAS}$  are used to select which byte of the DRAM is accessed during a read or write. The  $\overline{RAS0}$  controls the lower bank of DRAM which starts at 00000h in the address map and is bounded by the lower memory size selected in the LMCS register.  $\overline{RAS1}$  controls the upper bank of DRAM which ends at FFFFFh and is bounded by the upper memory size in the UMCS register. When  $\overline{RAS1}$  is enabled,  $\overline{UCS}$  is automatically disabled. Neither, either, or both DRAM banks can be activated.

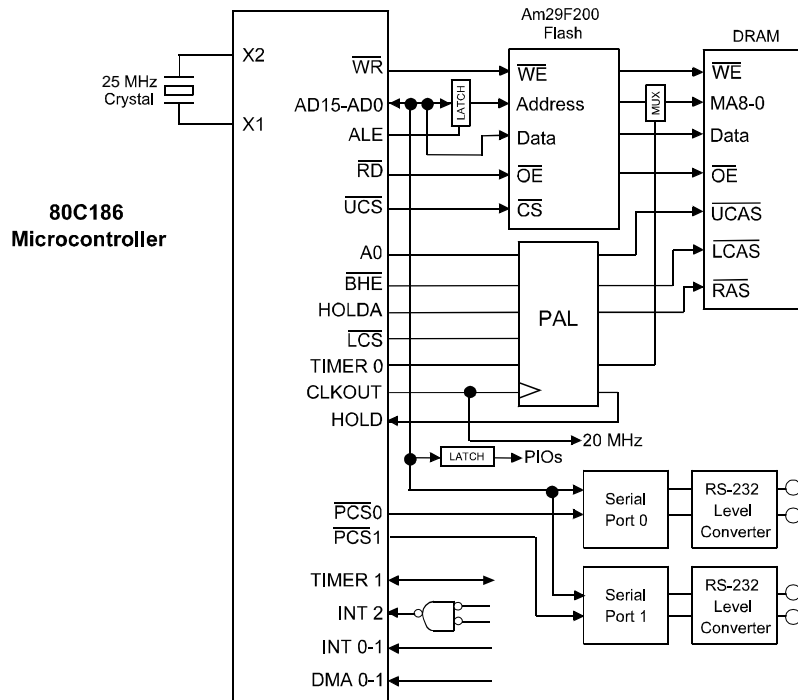

**Figure 2. 80C186 Microcontroller Example System Design**

## Enhanced Refresh Control Unit

The refresh control unit (RCU) is enhanced with two additional bits in the refresh counter to allow for longer refresh periods. The address generated during a refresh has been fixed to FFFFFh. When either bank of DRAM is enabled and the RCU is enabled, a  $\overline{\text{CAS}}$ -before- $\overline{\text{RAS}}$  refresh will be generated based on the time period coded into the refresh counter.

## Option to Overlap DRAM with $\overline{\text{PCS}}$

The peripheral chip selects ( $\overline{\text{PCS0}}$ – $\overline{\text{PCS6}}$ ) can overlap DRAM blocks with different wait states without external or internal bus contention. The  $\overline{\text{RAS0}}$  or  $\overline{\text{RAS1}}$  will assert along with the appropriate  $\overline{\text{PCS}}$ . The  $\overline{\text{UCAS}}$  and  $\overline{\text{LCAS}}$  will not assert, preventing the DRAM from writing erroneously or driving the data bus during a read. The  $\overline{\text{PCS}}$  must have the same or higher number of wait states than the DRAM. The  $\overline{\text{PCS}}$  bus width will be determined by the LSIZ or USIZ bus widths as programmed in the AUXCON register.

## Additional Serial Port Mode for DMA Support of 9-bit Protocols

A mode 7 was added to the serial port which enhances the direct memory access (DMA) support for 9-bit protocols. Using mode 2, the serial port can be programmed to interrupt only if the 9th bit is set, ignoring all 9th bit cleared byte receptions. Mode 3 receives all bytes, whether the 9th bit is set or cleared. Mode 7 also receives all bytes whether the 9th bit is set or cleared, but now an interrupt is generated when the 9th bit is set. This allows the DMA to service all receptions, but also allows the CPU to intervene when the trailer (9th bit set) is received. In all modes using DMA, the interrupts other than transmitter ready and character received interrupts can still be generated. This allows the DMA to handle the standard sending and receiving characters while the CPU can intervene when a non-standard event (e.g., framing error) occurs.

## Option to Boot from 8- or 16-bit Memory

The Am186ED/EDLV microcontrollers can boot from 8- or 16-bit-wide non-volatile memory, based on the state of the  $\overline{\text{S2/BTSEL}}$  pin. If  $\overline{\text{S2/BTSEL}}$  is pulled High or left floating, an internal pullup sets the boot mode option to 16-bit. If  $\overline{\text{S2/BTSEL}}$  is pulled resistively Low during reset, the boot mode option is for 8-bit. The status of the  $\overline{\text{S2/BTSEL}}$  pin is latched on the rising edge of reset.

If the 8-bit boot option is selected, the width of the memory region associated with  $\overline{\text{UCS}}$  can be changed in the AUXCON register. This allows for cheaper 8-bit-wide memory to be used for booting the microcontroller, while speed-critical code and data can be executed from 16-bit-wide lower memory. Eight-bit or 16-bit-wide peripherals can be used in the memory area between  $\overline{\text{LCS}}$  and  $\overline{\text{UCS}}$  or in the I/O space. The

entire memory map can be set to 16-bit or 8-bit or mixed between 8-bit and 16-bit based on the USIZ, LSIZ, MSIZ, and IOSIZ bits in the AUXCON register.

## Improved External Bus Master Support

When the bus is arbitrated away from the Am186ED/EDLV microcontrollers using the HOLD pin, the chip selects are driven High (negated) and then held High with an internal ~10-kohm pullup. This allows external bus masters to assert the chip selects by externally pulling them Low, without having to combine the chip selects from the Am186ED/EDLV microcontrollers and the external bus master in logic external to the Am186ED/EDLV microcontrollers. This internal pullup is activated for any bus arbitration, even if the pin is being used as a PIO input.

## PSRAM Controller Removed

The PSRAM mode found on the Am186ES/ESLV microcontrollers has been removed and replaced with a DRAM controller. This includes removal of the variant PSRAM  $\overline{\text{LCS}}$  timing and refresh strobe on  $\overline{\text{MCS3}}$ .





## TQFP PIN DESIGNATIONS—Am186ED/EDLV Microcontrollers

## Sorted by Pin Number

Pin No.	Name	Pin No.	Name	Pin No.	Name	Pin No.	Name
1	AD0	26	$\overline{RTS0/RTR0}/$ PIO20	51	A11	76	INT3/INTA1/IRQ
2	AD8	27	$\overline{BHE/ADEN}$	52	A10	77	INT2/INTA0/PWD/ PIO31
3	AD1	28	$\overline{WR}$	53	A9	78	INT1/SELECT
4	AD9	29	$\overline{RD}$	54	A8	79	INT0
5	AD2	30	ALE	55	A7	80	$\overline{UCS/ONCE1}$
6	AD10	31	ARDY	56	A6	81	$\overline{LCS/ONCE0}/$ RAS0
7	AD3	32	$\overline{S2/BTSEL}$	57	A5	82	$\overline{PCS6/A2}/PIO2$
8	AD11	33	$\overline{S1}$	58	A4	83	$\overline{PCS5/A1}/PIO3$
9	AD4	34	$\overline{S0}$	59	A3	84	V <sub>CC</sub>
10	AD12	35	GND	60	A2	85	$\overline{PCS3/RTS1}/$ RTR1/ PIO19
11	AD5	36	X1	61	V <sub>CC</sub>	86	$\overline{PCS2/CTS1}/$ ENRX1/PIO18
12	GND	37	X2	62	A1	87	GND
13	AD13	38	V <sub>CC</sub>	63	A0	88	$\overline{PCS1}/PIO17$
14	AD6	39	CLKOUTA	64	GND	89	$\overline{PCS0}/PIO16$
15	V <sub>CC</sub>	40	CLKOUTB	65	$\overline{WHB}$	90	V <sub>CC</sub>
16	AD14	41	GND	66	$\overline{WLB}$	91	$\overline{MCS2/LCAS}/$ PIO24
17	AD7	42	A19/PIO9	67	HLDA	92	$\overline{MCS3/RAS1}/$ PIO25
18	AD15	43	A18/PIO8	68	HOLD	93	GND
19	$\overline{S6/CLKDIV2}/PIO29$	44	V <sub>CC</sub>	69	SRDY/PIO6	94	$\overline{RES}$
20	$\overline{UZI}/PIO26$	45	A17/PIO7	70	NMI	95	TMRIN1/PIO0
21	TXD1/PIO27	46	A16	71	DT/ $\overline{R}$ /PIO4	96	TMROUT1/PIO1
22	RXD1/PIO28	47	A15	72	$\overline{DEN/DS}/PIO5$	97	TMROUT0/PIO10
23	$\overline{CTS0/ENRX0}/PIO21$	48	A14	73	$\overline{MCS0}/PIO14$	98	TMRIN0/PIO11
24	RXD0/PIO23	49	A13	74	$\overline{MCS1/UCAS}/$ PIO15	99	DRQ1/INT6/PIO13
25	TXD0/PIO22	50	A12	75	INT4/PIO30	100	DRQ0/INT5/PIO12



## TQFP PIN DESIGNATIONS—Am186ED/EDLV Microcontrollers

Sorted by Pin Name

Pin Name	No.	Pin Name	No.	Pin Name	No.	Pin Name	No.
A0	63	AD5	11	GND	87	RXD1	22
A1	62	AD6	14	GND	93	$\overline{S}0$	34
A2	60	AD7	17	HLDA	67	$\overline{S}1$	33
A3	59	AD8	2	HOLD	68	$\overline{S}2$ /BTSEL	32
A4	58	AD9	4	INT0	79	S6/ $\overline{CLKDIV}2$ / PIO29	19
A5	57	AD10	6	INT1/SELECT	78	SRDY/PIO6	69
A6	56	AD11	8	INT2/ $\overline{INTA}0$ /PWD/ PIO31	77	TMRIN0/PIO11	98
A7	55	AD12	10	INT3/ $\overline{INTA}1$ /IRQ	76	TMRIN1/PIO0	95
A8	54	AD13	13	INT4/PIO30	75	TMROUT0/ PIO10	97
A9	53	AD14	16	$\overline{LCS}$ / $\overline{ONCE}0$ /RAS0	81	TMROUT1/PIO1	96
A10	52	AD15	18	$\overline{MCS}0$ /PIO14	73	TXD0/PIO22	25
A11	51	ALE	30	$\overline{MCS}1$ / $\overline{UCAS}$ / PIO15	74	TXD1	21
A12	50	ARDY	31	$\overline{MCS}2$ / $\overline{LCAS}$ /PIO24	91	$\overline{UCS}$ / $\overline{ONCE}1$	80
A13	49	$\overline{BHE}$ / $\overline{ADEN}$	27	$\overline{MCS}3$ /RAS1/PIO25	92	$\overline{UZI}$ /PIO26	20
A14	48	CLKOUTA	39	NMI	70	V <sub>CC</sub>	15
A15	47	CLKOUTB	40	$\overline{PCS}0$ /PIO16	89	V <sub>CC</sub>	38
A16	46	$\overline{CTS}0$ / $\overline{ENRX}0$ / PIO21	23	$\overline{PCS}1$ /PIO17	88	V <sub>CC</sub>	44
A17/PIO7	45	$\overline{DEN}$ / $\overline{DS}$ /PIO5	72	$\overline{PCS}2$ / $\overline{CTS}1$ / $\overline{ENRX}1$ /PIO18	86	V <sub>CC</sub>	61
A18/PIO8	43	DRQ0/INT5/PIO12	100	$\overline{PCS}3$ / $\overline{RTS}1$ / $\overline{RTR}1$ / PIO19	85	V <sub>CC</sub>	84
A19/PIO9	42	DRQ1/INT6/PIO13	99	$\overline{PCS}5$ /A1/PIO3	83	V <sub>CC</sub>	90
AD0	1	DT/ $\overline{R}$ /PIO4	71	$\overline{PCS}6$ /A2/PIO2	82	$\overline{WHB}$	65
AD1	3	GND	12	$\overline{RD}$	29	$\overline{WLB}$	66
AD2	5	GND	35	$\overline{RES}$	94	$\overline{WR}$	28
AD3	7	GND	41	RTS0/ $\overline{RTR}0$ /PIO20	26	X1	36
AD4	9	GND	64	RXD0/PIO23	24	X2	37

# PQFP CONNECTION DIAGRAMS AND PINOUTS

## Am186ED/EDLV Microcontrollers

### Top Side View—100-Pin Plastic Quad Flat Pack (PQFP)

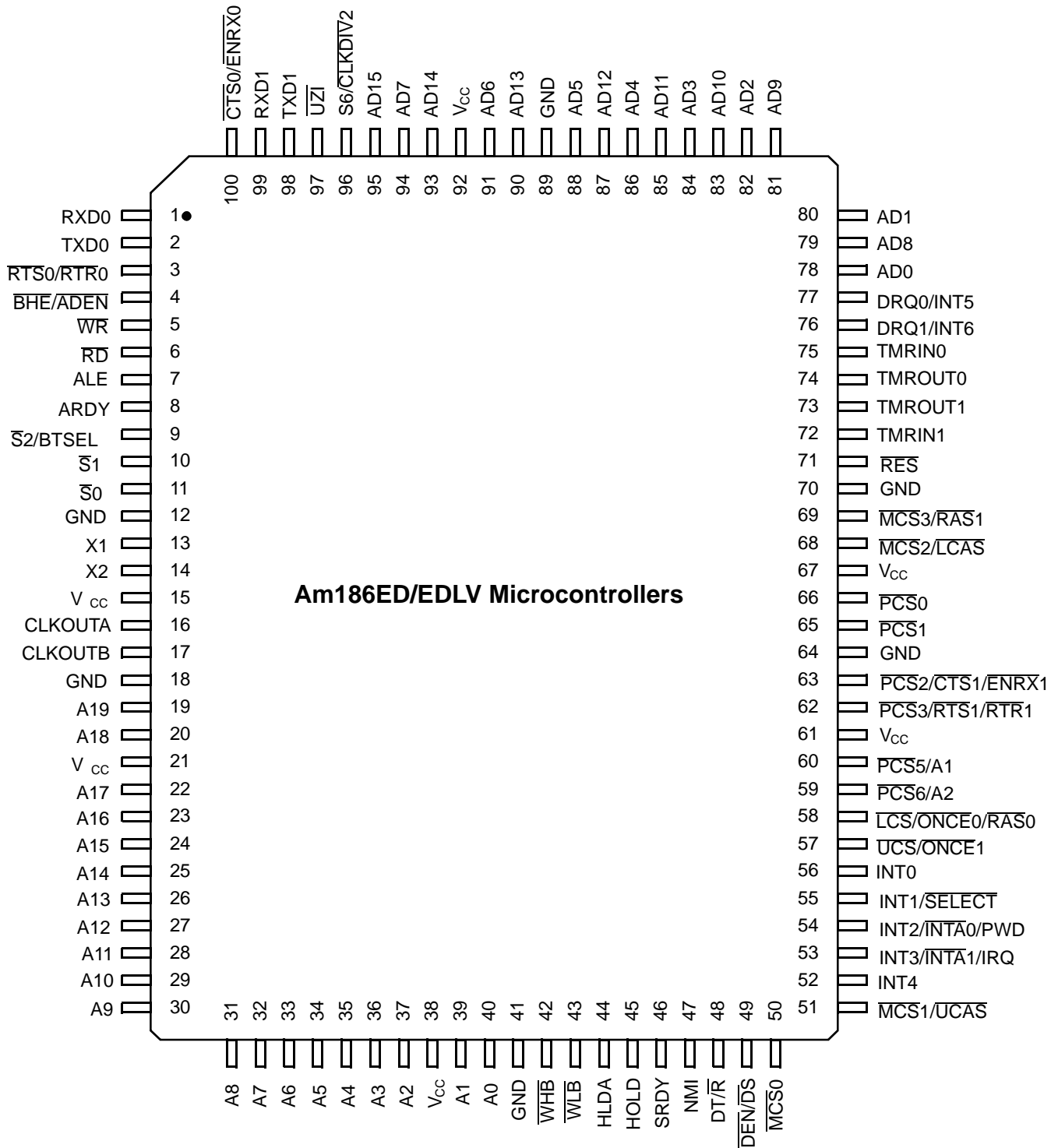

**Note:**  
Pin 1 is marked for orientation.

## PQFP PIN DESIGNATIONS—Am186ED/EDLV Microcontrollers

Sorted by Pin Number

Pin No.	Name	Pin No.	Name	Pin No.	Name	Pin No.	Name
1	RXD0/PIO23	26	A13	51	$\overline{\text{MCS1}}/\overline{\text{UCAS}}/\text{PIO15}$	76	DRQ1/INT6/PIO13
2	TXD0/PIO22	27	A12	52	INT4/PIO30	77	DRQ0/INT5/PIO12
3	$\overline{\text{RTS0}}/\overline{\text{RTR0}}/\text{PIO20}$	28	A11	53	INT3/ $\overline{\text{INTA1}}$ /IRQ	78	AD0
4	$\overline{\text{BHE}}/\overline{\text{ADEN}}$	29	A10	54	INT2/ $\overline{\text{INTA0}}$ /PWD/ PIO31	79	AD8
5	$\overline{\text{WR}}$	30	A9	55	INT1/SELECT	80	AD1
6	$\overline{\text{RD}}$	31	A8	56	INT0	81	AD9
7	ALE	32	A7	57	$\overline{\text{UCS}}/\overline{\text{ONCE1}}$	82	AD2
8	ARDY	33	A6	58	$\overline{\text{LCS}}/\overline{\text{ONCE0}}/\overline{\text{RAS0}}$	83	AD10
9	$\overline{\text{S2}}/\overline{\text{BTSEL}}$	34	A5	59	$\overline{\text{PCS6}}/\text{A2}/\text{PIO2}$	84	AD3
10	$\overline{\text{S1}}$	35	A4	60	$\overline{\text{PCS5}}/\text{A1}/\text{PIO3}$	85	AD11
11	$\overline{\text{S0}}$	36	A3	61	V <sub>CC</sub>	86	AD4
12	GND	37	A2	62	$\overline{\text{PCS3}}/\overline{\text{RTS1}}/\overline{\text{RTR1}}/\text{PIO19}$	87	AD12
13	X1	38	V <sub>CC</sub>	63	$\overline{\text{PCS2}}/\overline{\text{CTS1}}/\overline{\text{ENRX1}}/\text{PIO18}$	88	AD5
14	X2	39	A1	64	GND	89	GND
15	V <sub>CC</sub>	40	A0	65	$\overline{\text{PCS1}}/\text{PIO17}$	90	AD13
16	CLKOUTA	41	GND	66	$\overline{\text{PCS0}}/\text{PIO16}$	91	AD6
17	CLKOUTB	42	$\overline{\text{WHB}}$	67	V <sub>CC</sub>	92	V <sub>CC</sub>
18	GND	43	$\overline{\text{WLB}}$	68	$\overline{\text{MCS2}}/\overline{\text{LCAS}}/\text{PIO24}$	93	AD14
19	A19/PIO9	44	HLDA	69	$\overline{\text{MCS3}}/\overline{\text{RAS1}}/\text{PIO25}$	94	AD7
20	A18/PIO8	45	HOLD	70	GND	95	AD15
21	V <sub>CC</sub>	46	SRDY/PIO6	71	RES	96	S6/ $\overline{\text{CLKDIV2}}$ /PIO29
22	A17/PIO7	47	NMI	72	TMRIN1/PIO0	97	$\overline{\text{UZI}}/\text{PIO26}$
23	A16	48	DT/ $\overline{\text{R}}$ /PIO4	73	TMROUT1/PIO1	98	TXD1/PIO27
24	A15	49	$\overline{\text{DEN}}/\overline{\text{DS}}/\text{PIO5}$	74	TMROUT0/PIO10	99	RXD1/PIO28
25	A14	50	$\overline{\text{MCS0}}/\text{PIO14}$	75	TMRIN0/PIO11	100	$\overline{\text{CTS0}}/\overline{\text{ENRX0}}/\text{PIO21}$

## PQFP PIN DESIGNATIONS—Am186ED/EDLV Microcontrollers

## Sorted by Pin Name

Pin Name	No.	Pin Name	No.	Pin Name	No.	Pin Name	No.
A0	40	AD5	88	GND	70	RXD1/PIO28	99
A1	39	AD6	91	GND	89	$\overline{S}0$	11
A2	37	AD7	94	HLDA	44	$\overline{S}1$	10
A3	36	AD8	79	HOLD	45	$\overline{S}2$ /BTSEL	9
A4	35	AD9	81	INT0	56	S6/CLKDIV2/ PIO29	96
A5	34	AD10	83	INT1/SELECT	55	SRDY/PIO6	46
A6	33	AD11	85	INT2/INTA0/ PWD/PIO31	54	TMRIN0/PIO11	75
A7	32	AD12	87	INT3/INTA1/IRQ	53	TMRIN1/PIO0	72
A8	31	AD13	90	INT4/PIO30	52	TMROUT0/ PIO10	74
A9	30	AD14	93	$\overline{LCS}$ /ONCE0/RAS0	58	TMROUT1/PIO1	73
A10	29	AD15	95	$\overline{MCS}0$ /PIO14	50	TXD0/PIO22	2
A11	28	ALE	7	$\overline{MCS}1$ /UCAS/PIO15	51	TXD1/PIO27	98
A12	27	ARDY	8	$\overline{MCS}2$ /LCAS/PIO24	68	$\overline{UCS}$ /ONCE1	57
A13	26	$\overline{BHE}$ /ADEN	4	$\overline{MCS}3$ /RAS1/PIO25	69	$\overline{UZI}$ /PIO26	97
A14	25	CLKOUTA	16	NMI	47	V <sub>CC</sub>	15
A15	24	CLKOUTB	17	$\overline{PCS}0$ /PIO16	66	V <sub>CC</sub>	21
A16	23	$\overline{CTS}0$ /ENRX0/ PIO21	100	$\overline{PCS}1$ /PIO17	65	V <sub>CC</sub>	38
A17/PIO7	22	$\overline{DEN}$ /DS/PIO5	49	$\overline{PCS}2$ /CTS1/ENRX1/ PIO18	63	V <sub>CC</sub>	61
A18/PIO8	20	DRQ0/INT5/PIO12	77	$\overline{PCS}3$ /RTS1/RTR1/ PIO19	62	V <sub>CC</sub>	67
A19/PIO9	19	DRQ1/INT6/PIO13	76	$\overline{PCS}5$ /A1/PIO3	60	V <sub>CC</sub>	92
AD0	78	DT/R/PIO4	48	$\overline{PCS}6$ /A2/PIO2	59	$\overline{WHB}$	42
AD1	80	GND	12	$\overline{RD}$	6	$\overline{WLB}$	43
AD2	82	GND	18	$\overline{RES}$	71	$\overline{WR}$	5
AD3	84	GND	41	RTS0/RTR0/PIO20	3	X1	13
AD4	86	GND	64	RXD0/PIO23	1	X2	14

LOGIC SYMBOL—Am186ED/EDLV MICROCONTROLLERS

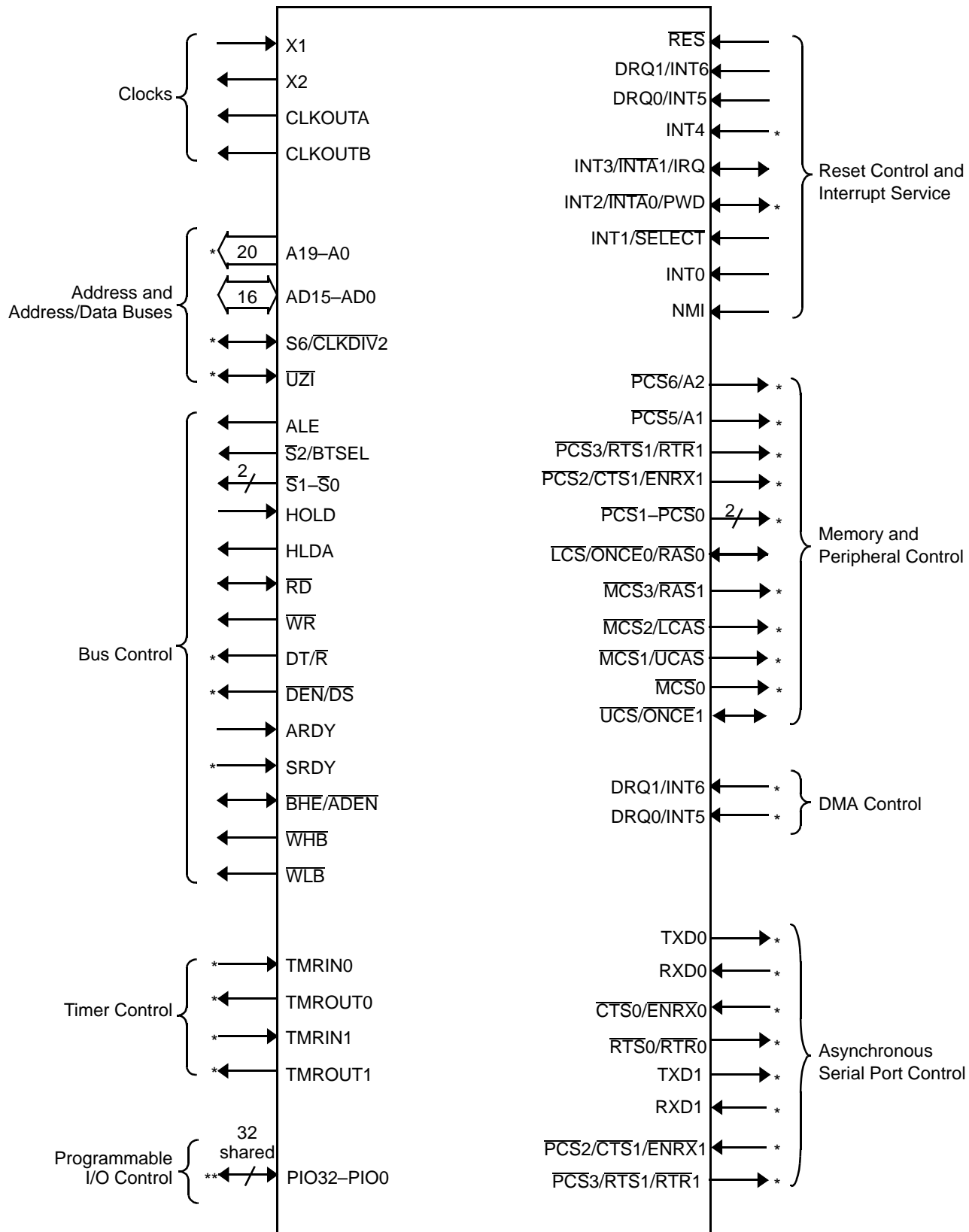

Notes:

\* These signals are the normal function of a pin that can be used as a PIO. See Pin Descriptions beginning on page 21 and Table 2 on page 29 for information on shared function.

\*\* All PIO signals are shared with other physical pins.

## PIN DESCRIPTIONS

### Pins That Are Used by Emulators

The following pins are used by emulators: A19–A0, AD7–AD0, ALE, BHE/ADEN, CLKOUTA, RD, S2–S0, S6/CLKDIV2, and UZI.

Many emulators require S6/CLKDIV2 and UZI to be configured in their normal functionality as S6 and UZI, not as PIOs. If BHE/ADEN is held Low during the rising edge of RES, S6 and UZI are configured in their normal functionality.

### Pin Terminology

The following terms are used to describe the pins:

**Input**—An input-only pin.

**Output**—An output-only pin.

**Input/Output**—A pin that can be either input or output (I/O).

**Synchronous**—Synchronous inputs must meet setup and hold times in relation to CLKOUTA. Synchronous outputs are synchronous to CLKOUTA.

**Asynchronous**—Inputs or outputs that are asynchronous to CLKOUTA.

### A19–A0 (A19/PIO9, A18/PIO8, A17/PIO7)

#### Address Bus (output, three-state, synchronous)

These pins supply nonmultiplexed memory or I/O addresses to the system one half of a CLKOUTA period earlier than the multiplexed address and data bus (AD15–AD0). During a bus hold or reset condition, the address bus is in a high-impedance state.

While the Am186ED/EDLV microcontrollers are directly connected to DRAM, A19–A0 will serve as the nonmultiplexed address bus for SRAM, FLASH, PROM, EPROM, and peripherals. The odd address pins (A17, A15, A13, A11, A9, A7, A5, A3, and A1) will have both the row and column address during a DRAM space access. The odd address signals connect directly to the row and column multiplexed address bus of the DRAM. The even address pins (A18, A16, A14, A12, A10, A8, A6, A4, A2, and A0) and A19 will have the initial address asserted during the full DRAM access. These signals will not transition during a DRAM access.

### AD15–AD8

#### Address and Data Bus (input/output, three-state, synchronous, level-sensitive)

**AD15–AD8**—These time-multiplexed pins supply memory or I/O addresses and data to the system. This bus can supply an address to the system during the first period of a bus cycle ( $t_1$ ). It supplies data to the

system during the remaining periods of that cycle ( $t_2$ ,  $t_3$ , and  $t_4$ ).

The address phase of these pins can be disabled. See the ADEN description with the BHE/ADEN pin. When WHB is deasserted, these pins are three-stated during  $t_2$ ,  $t_3$ , and  $t_4$ .

During a bus hold or reset condition, the address and data bus is in a high-impedance state.

During a power-on reset, the address and data bus pins (AD15–AD0) can also be used to load system configuration information into the internal reset configuration register.

When accesses are made to 8-bit-wide memory regions, AD15–AD8 drive their corresponding address signals throughout the access. If the disable address phase and 8-bit mode are selected (see the ADEN description with the BHE/ADEN pin), then AD15–AD8 are three-stated during  $t_1$  and driven with their corresponding address signal from  $t_2$  to  $t_4$ .

### AD7–AD0

#### Address and Data Bus (input/output, three-state, synchronous, level-sensitive)

These time-multiplexed pins supply partial memory or I/O addresses, as well as data, to the system. This bus supplies the low-order 8 bits of an address to the system during the first period of a bus cycle ( $t_1$ ), and it supplies data to the system during the remaining periods of that cycle ( $t_2$ ,  $t_3$ , and  $t_4$ ). In 8-bit mode, AD7–AD0 supplies the data for both high and low bytes.

The address phase of these pins can be disabled. See the ADEN pin description with the BHE/ADEN pin. When WLB is deasserted, these pins are three-stated during  $t_2$ ,  $t_3$ , and  $t_4$ .

During a bus hold or reset condition, the address and data bus is in a high-impedance state.

During a power-on reset, the address and data bus pins (AD15–AD0) can also be used to load system configuration information into the internal reset configuration register.

### ALE

#### Address Latch Enable (output, synchronous)

This pin indicates to the system that an address appears on the address and data bus (AD15–AD0). The address is guaranteed to be valid on the trailing edge of ALE. This pin is three-stated during ONCE mode.

ALE is three-stated and held resistively Low during a bus hold condition. In addition, ALE has a weak internal pulldown resistor that is active during reset, so that an external device does not get a spurious ALE during reset.

## ARDY

### Asynchronous Ready (input, asynchronous, level-sensitive)

This pin is a true asynchronous ready that indicates to the microcontroller that the addressed memory space or I/O device will complete a data transfer. The ARDY pin is asynchronous to CLKOUTA and is active High. To guarantee the number of wait states inserted, ARDY or SRDY must be synchronized to CLKOUTA. If the falling edge of ARDY is not synchronized to CLKOUTA as specified, an additional clock period can be added.

To always assert the ready condition to the microcontroller, tie ARDY High. If the system does not use ARDY, tie the pin Low to yield control to SRDY.

## BHE/ADEN

### Bus High Enable (three-state, output, synchronous)

### Address Enable (input, internal pullup)

**BHE**—During a memory access, this pin and the least-significant address bit (AD0 or A0) indicate to the system which bytes of the data bus (upper, lower, or both) participate in a bus cycle. The BHE/ADEN and AD0 pins are encoded as shown in Table 1.

Table 1. Data Byte Encoding

BHE	AD0	Type of Bus Cycle
0	0	Word Transfer
0	1	High Byte Transfer (Bits 15–8)
1	0	Low Byte Transfer (Bits 7–0)
1	1	Reserved

BHE is asserted during  $t_1$  and remains asserted through  $t_3$  and  $t_W$ . BHE does not need to be latched. BHE floats during bus hold and reset.

WLB and WHB implement the functionality of BHE and AD0 for High and Low byte-write enables. UCAS and LCAS implement High and Low-byte selection for DRAM devices.

BHE/ADEN also signals DRAM refresh cycles when using the multiplexed address and data (AD) bus. A refresh cycle is indicated when both BHE/ADEN and AD0 are High. During refresh cycles, the A bus is indeterminate and the AD bus is driven to FFFFh during the address phase of the AD bus cycle. For this reason, the A0 signal cannot be used in place of the AD0 signal to determine refresh cycles.

**ADEN**—If BHE/ADEN is held High or left floating during power-on reset, the address portion of the AD bus (AD15–AD0) is enabled or disabled during LCS and UCS bus cycles based on the DA bit in the LMCS and UMCS registers. If the DA bit is set, the AD bus will

not drive the address during  $t_1$ . There is a weak internal pullup resistor on BHE/ADEN so no external pullup is required. Disabling the address phase reduces power consumption.

If BHE/ADEN is held Low on power-on reset, the AD bus drives both addresses and data, regardless of the DA bit setting. The pin is sampled on the rising edge of RES. (S6 and UZI also assume their normal functionality in this instance. See Table 2 on page 29.) The internal pullup on ADEN is  $\sim 9$  kohm.

**Note:** For 8-bit accesses, AD15–AD8 are driven with addresses during the  $t_2$ – $t_4$  bus cycle, regardless of the setting of the DA bit in the UMCS and LMCS registers.

## CLKOUTA

### Clock Output A (output, synchronous)

This pin supplies the internal clock to the system. Depending on the value of the system configuration register (SYSCON), CLKOUTA operates at either the PLL frequency (X1), the power-save frequency, or is held Low. CLKOUTA remains active during reset and bus hold conditions.

All AC timing specs that use a clock relate to CLKOUTA.

## CLKOUTB

### Clock Output B (output, synchronous)

This pin supplies an additional clock with a delayed output compared to CLKOUTA. Depending upon the value of the system configuration register (SYSCON), CLKOUTB operates at either the PLL frequency (X1), the power-save frequency, or is held Low. CLKOUTB remains active during reset and bus hold conditions.

CLKOUTB is not used for AC timing specs.

## CTS0/ENRX0/PIO21

### Clear-to-Send 0 (input, asynchronous)

### Enable-Receiver-Request 0 (input, asynchronous)

**CTS0**—This pin provides the Clear-to-Send signal for asynchronous serial port 0 when the ENRX0 bit in the AUXCON register is 0 and hardware flow control is enabled for the port (FC bit in the serial port 0 control register is set). The CTS0 signal gates the transmission of data from the associated serial port transmit register. When CTS0 is asserted, the transmitter begins transmission of a frame of data, if any is available. If CTS0 is deasserted, the transmitter holds the data in the serial port transmit register. The value of CTS0 is checked only at the beginning of the transmission of the frame.

**ENRX0**—This pin provides the Enable Receiver Request for asynchronous serial port 0 when the ENRX0 bit in the AUXCON register is 1 and hardware flow control is enabled for the port (FC bit in the serial



port 0 control register is set). The  $\overline{\text{ENRX0}}$  signal enables the receiver for the associated serial port.

### $\overline{\text{DEN}}/\overline{\text{DS}}/\text{PIO5}$

**Data Enable (output, three-state, synchronous)**  
**Data Strobe (output, three-state, synchronous)**

$\overline{\text{DEN}}$ —This pin supplies an output enable to an external data-bus transceiver.  $\overline{\text{DEN}}$  is asserted during memory, I/O, and interrupt acknowledge cycles.  $\overline{\text{DEN}}$  is deasserted when  $\text{DT}/\overline{\text{R}}$  changes state.  $\overline{\text{DEN}}$  floats during a bus hold or reset condition.

$\overline{\text{DS}}$ —The data strobe provides a signal where the write cycle timing is identical to the read cycle timing. When used with other control signals,  $\overline{\text{DS}}$  provides an interface for 68K-type peripherals without the need for additional system interface logic.

When  $\overline{\text{DS}}$  is asserted, addresses are valid. When  $\overline{\text{DS}}$  is asserted on writes, data is valid. When  $\overline{\text{DS}}$  is asserted on reads, data can be asserted on the AD bus.

**Note:** This pin resets to  $\overline{\text{DEN}}$ .

### $\text{DRQ0}/\text{INT5}/\text{PIO12}$

**DMA Request 0 (input, synchronous, level-sensitive)**  
**Maskable Interrupt Request 5 (input, asynchronous, edge-triggered)**

$\text{DRQ0}$ —This pin indicates to the microcontroller that an external device is ready for DMA channel 0 to perform a transfer.  $\text{DRQ0}$  is level-triggered and internally synchronized.  $\text{DRQ0}$  is not latched and must remain active until serviced.

$\text{INT5}$ —If DMA 0 is not enabled or DMA 0 is not being used with external synchronization,  $\text{INT5}$  can be used as an additional external interrupt request.  $\text{INT5}$  shares the DMA 0 interrupt type (0Ah) and register control bits.

$\text{INT5}$  is edge-triggered only and must be held until the interrupt is acknowledged.

### $\text{DRQ1}/\text{INT6}/\text{PIO13}$

**DMA Request 1 (input, synchronous, level-sensitive)**  
**Maskable Interrupt Request 6 (input, asynchronous, edge-triggered)**

$\text{DRQ1}$ —This pin indicates to the microcontroller that an external device is ready for DMA channel 1 to perform a transfer.  $\text{DRQ1}$  is level-triggered and internally synchronized.  $\text{DRQ1}$  is not latched and must remain active until serviced.

$\text{INT6}$ —If DMA 1 is not enabled or DMA 1 is not being used with external synchronization,  $\text{INT6}$  can be used as an additional external interrupt request.  $\text{INT6}$  shares the DMA 1 interrupt type (0Bh) and register control bits.

$\text{INT6}$  is edge-triggered only and must be held until the interrupt is acknowledged.

### $\text{DT}/\overline{\text{R}}/\text{PIO4}$

**Data Transmit or Receive (output, three-state, synchronous)**

This pin indicates in which direction data should flow through an external data-bus transceiver. When  $\text{DT}/\overline{\text{R}}$  is asserted High, the microcontroller transmits data. When this pin is deasserted Low, the microcontroller receives data.  $\text{DT}/\overline{\text{R}}$  floats during a bus hold or reset condition.

### GND

#### Ground

Ground pins connect the microcontroller to the system ground.

### HLDA

**Bus Hold Acknowledge (output, synchronous)**

This pin is asserted High to indicate to an external bus master that the microcontroller has released control of the local bus. When an external bus master requests control of the local bus (by asserting HOLD), the microcontroller completes the bus cycle in progress. It then relinquishes control of the bus to the external bus master by asserting HLDA and floating  $\overline{\text{DEN}}$ ,  $\overline{\text{RD}}$ ,  $\overline{\text{WR}}$ ,  $\overline{\text{S2}}\text{--}\overline{\text{S0}}$ ,  $\text{AD15--AD0}$ ,  $\text{S6}$ ,  $\text{A19--A0}$ ,  $\overline{\text{BHE}}$ ,  $\overline{\text{WHB}}$ ,  $\overline{\text{WLB}}$ , and  $\text{DT}/\overline{\text{R}}$ . The following chip selects are three-stated (then will be held High with an ~10-kohm resistor):  $\overline{\text{UCS}}$ ,  $\overline{\text{LCS}}$ ,  $\overline{\text{MCS3}}\text{--}\overline{\text{MCS0}}$ ,  $\overline{\text{PCS6}}\text{--}\overline{\text{PCS5}}$ ,  $\overline{\text{PCS3}}\text{--}\overline{\text{PCS0}}$ ,  $\overline{\text{RAS0}}$ ,  $\overline{\text{RAS1}}$ ,  $\overline{\text{UCAS}}$ , and  $\overline{\text{LCAS}}$ . ALE is also three-stated (then will be held Low with an ~10-kohm resistor).

When the external bus master has finished using the local bus, it indicates this to the microcontroller by deasserting HOLD. The microcontroller responds by deasserting HLDA.

If the microcontroller requires access to the bus (for example, to refresh), it will deassert HLDA before the external bus master deasserts HOLD. The external bus master must be able to deassert HOLD and allow the microcontroller access to the bus. See the timing diagrams for bus hold on page 86.

### HOLD

**Bus Hold Request (input, synchronous, level-sensitive)**

This pin indicates to the microcontroller that an external bus master needs control of the local bus.

The Am186ED/EDLV microcontrollers' HOLD latency time, that is, the time between HOLD request and HOLD acknowledge, is a function of the activity occurring in the processor when the HOLD request is received. A HOLD request is second only to DRAM

refresh requests in priority of activity requests received by the processor.

For more information, see the HLDA pin description on page 23.

## INT0

### Maskable Interrupt Request 0 (input, asynchronous)

This pin indicates to the microcontroller that an interrupt request has occurred. If the INT0 pin is not masked, the microcontroller transfers program execution to the location specified by the INT0 vector in the microcontroller interrupt vector table.

Interrupt requests are synchronized internally and can be edge-triggered or level-triggered. To guarantee interrupt recognition, the requesting device must continue asserting INT0 until the request is acknowledged.

## INT1/SELECT

### Maskable Interrupt Request 1 (input, asynchronous)

#### Slave Select (input, asynchronous)

**INT1**—This pin indicates to the microcontroller that an interrupt request has occurred. If INT1 is not masked, the microcontroller transfers program execution to the location specified by the INT1 vector in the microcontroller interrupt vector table.

Interrupt requests are synchronized internally and can be edge-triggered or level-triggered. To guarantee interrupt recognition, the requesting device must continue asserting INT1 until the request is acknowledged.

**SELECT**—When the microcontroller interrupt control unit is operating as a slave to an external interrupt controller, this pin indicates to the microcontroller that an interrupt type appears on the address and data bus. The INT0 pin must indicate to the microcontroller that an interrupt has occurred before the **SELECT** pin indicates to the microcontroller that the interrupt type appears on the bus.

## INT2/INTA0/PWD/PIO31

### Maskable Interrupt Request 2 (input, asynchronous)

#### Interrupt Acknowledge 0 (output, synchronous) Pulse Width Demodulator (input, Schmitt trigger)

**INT2**—This pin indicates to the microcontroller that an interrupt request has occurred. If the INT2 pin is not masked, the microcontroller transfers program execution to the location specified by the INT2 vector in the microcontroller interrupt vector table.

Interrupt requests are synchronized internally and can be edge-triggered or level-triggered. To guarantee

interrupt recognition, the requesting device must continue asserting INT2 until the request is acknowledged. INT2 becomes  $\overline{\text{INTA0}}$  when INT0 is configured in cascade mode.

**INTA0**—When the microcontroller interrupt control unit is operating in cascade mode, this pin indicates to the system that the microcontroller needs an interrupt type to process the interrupt request on INT0. The peripheral issuing the interrupt request must provide the microcontroller with the corresponding interrupt type.

**PWD**—If pulse width demodulation is enabled, PWD processes a signal through the Schmitt trigger. PWD is used internally to drive TIMERIN0 and INT2, and PWD is inverted internally to drive TIMERIN1 and INT4. If INT2 and INT4 are enabled and timer 0 and timer 1 are properly configured, the pulse width of the alternating PWD signal can be calculated by comparing the values in timer 0 and timer 1.

In PWD mode, the signals TIMERIN0/PIO11, TIMERIN1/PIO0, and INT4/PIO30 can be used as PIOs. If they are not used as PIOs, they are ignored internally. The level of INT2/ $\overline{\text{INTA0}}$ /PWD/PIO31 is reflected in the PIO data register for PIO31 as if it was a PIO.

## INT3/ $\overline{\text{INTA1}}$ /IRQ

### Maskable Interrupt Request 3 (input, asynchronous)

#### Interrupt Acknowledge 1 (output, synchronous) Slave Interrupt Request (output, synchronous)

**INT3**—This pin indicates to the microcontroller that an interrupt request has occurred. If the INT3 pin is not masked, the microcontroller then transfers program execution to the location specified by the INT3 vector in the microcontroller interrupt vector table.

Interrupt requests are synchronized internally, and can be edge-triggered or level-triggered. To guarantee interrupt recognition, the requesting device must continue asserting INT3 until the request is acknowledged. INT3 becomes  $\overline{\text{INTA1}}$  when INT1 is configured in cascade mode.

**$\overline{\text{INTA1}}$** —When the microcontroller interrupt control unit is operating in cascade mode, this pin indicates to the system that the microcontroller needs an interrupt type to process the interrupt request on INT1. The peripheral issuing the interrupt request must provide the microcontroller with the corresponding interrupt type.

**IRQ**—When the microcontroller interrupt control unit is operating as a slave to an external master interrupt controller, this pin lets the microcontroller issue an interrupt request to the external master interrupt controller.

**INT4/PIO30****Maskable Interrupt Request 4 (input, asynchronous)**

This pin indicates to the microcontroller that an interrupt request has occurred. If the INT4 pin is not masked, the microcontroller then transfers program execution to the location specified by the INT4 vector in the microcontroller interrupt vector table.

Interrupt requests are synchronized internally, and can be edge-triggered or level-triggered. To guarantee interrupt recognition, the requesting device must continue asserting INT4 until the request is acknowledged.

When pulse width demodulation mode is enabled, the INT4 signal is used internally to indicate a High-to-Low transition on the PWD signal. When pulse width demodulation mode is enabled, INT4/PIO30 can be used as a PIO.

 **$\overline{\text{LCS}}/\overline{\text{ONCE0}}/\text{RAS0}$** **Lower Memory Chip Select (output, synchronous, internal pullup)****ONCE Mode Request 0 (input)  
Row Address Strobe 0**

$\overline{\text{LCS}}$ —This pin indicates to the system that a memory access is in progress to the lower memory block. The base address and size of the lower memory block are programmable up to 512 Kbytes.  $\overline{\text{LCS}}$  is configured for 8-bit or 16-bit bus size by the auxiliary configuration register.

$\overline{\text{LCS}}$  is three-stated and held resistively High during a bus hold condition. In addition,  $\overline{\text{LCS}}$  has an ~9-kohm internal pullup resistor that is active during reset.

$\overline{\text{ONCE0}}$ —During reset, this pin and  $\overline{\text{ONCE1}}$  indicate to the microcontroller the mode in which it should operate.  $\overline{\text{ONCE0}}$  and  $\overline{\text{ONCE1}}$  are sampled on the rising edge of  $\overline{\text{RES}}$ . If both pins are asserted Low, the microcontroller enters ONCE mode; otherwise, it operates normally.

In ONCE mode, all pins assume a high-impedance state and remain in that state until a subsequent reset occurs. To guarantee that the microcontroller does not inadvertently enter ONCE mode,  $\overline{\text{ONCE0}}$  has a weak internal pullup resistor that is active only during reset.

$\text{RAS0}$ —This pin is the row address strobe for the lower DRAM block. The selection of  $\text{RAS0}$  or  $\overline{\text{LCS}}$  functionality, along with their configurations, are set using the LMCS register.

$\text{RAS0}$  is three-stated and held resistively High during a bus hold condition. In addition,  $\text{RAS0}$  has a weak internal pullup resistor that is active during reset.

 **$\overline{\text{MCS0}}/\text{PIO14}$** **Midrange Memory Chip Select 0 (output, synchronous, internal pullup)**

This pin indicates to the system that a memory access is in progress to the corresponding region of the midrange memory block. The base address and size of the midrange memory block are programmable.  $\overline{\text{MCS0}}$  can be programmed as the chip select for the entire middle chip select address range. This mode is recommended when using DRAM since the  $\overline{\text{MCS1}}$ ,  $\overline{\text{MCS2}}$ , and  $\overline{\text{MCS3}}$  chip selects function as  $\overline{\text{RAS}}$  and  $\overline{\text{CAS}}$  signals for the DRAM interface and are not available as chip selects.

$\overline{\text{MCS0}}$  is configured for 8-bit or 16-bit bus size by the auxiliary configuration register.  $\overline{\text{MCS0}}$  is three-stated and held resistively High during a bus hold condition. In addition,  $\overline{\text{MCS0}}$  has a weak internal pullup resistor that is active during reset.

 **$\overline{\text{MCS1}}/\overline{\text{UCAS}}/\text{PIO15}$** **Midrange Memory Chip Select (output, synchronous, internal pullup)  
Upper Column Address Strobe**

This pin indicates to the system that a memory access is in progress to the corresponding region of the midrange memory block. The base address and size of the midrange memory block are programmable.  $\overline{\text{MCS1}}$  is configured for 8-bit or 16-bit bus size via the auxiliary configuration register.

$\overline{\text{MCS1}}$  is three-stated and held resistively High during a bus hold condition. In addition,  $\overline{\text{MCS1}}$  has a weak internal pullup resistor that is active during reset.

If  $\overline{\text{MCS0}}$  is programmed to be active for the entire middle chip-select range, then this signal is available as a PIO or a DRAM control. If this signal is not programmed as a PIO or DRAM control and if  $\overline{\text{MCS0}}$  is programmed for the entire middle chip-select range, this signal operates normally.

$\overline{\text{UCAS}}$ —When either bank of DRAM is activated, the  $\overline{\text{UCAS}}$  functionality is enabled. The  $\overline{\text{UCAS}}$  activates when the DRAM access is for the AD15–AD8 byte.  $\overline{\text{UCAS}}$  also activates at the start of a DRAM refresh access.

$\overline{\text{UCAS}}$  is three-stated and held resistively High during a bus hold condition. In addition,  $\overline{\text{UCAS}}$  has a weak internal pullup resistor that is active during reset.

 **$\overline{\text{MCS2}}/\overline{\text{LCAS}}/\text{PIO24}$** **Midrange Memory Chip Select (output, synchronous, internal pullup)  
Lower Column Address Strobe**

This pin indicates to the system that a memory access is in progress to the corresponding region of the midrange memory block. The base address and size of

the midrange memory block are programmable.  $\overline{MCS2}$  is configured for 8-bit or 16-bit bus size via the auxiliary configuration register.

$\overline{MCS2}$  is three-stated and held resistively High during a bus hold condition. In addition, it has a weak internal pullup resistor that is active during reset.

If  $\overline{MCS0}$  is programmed to be active for the entire middle chip-select range, then this signal is available as a PIO or a DRAM control. If this pin is not programmed as a PIO or DRAM control and if  $\overline{MCS0}$  is programmed for the whole middle chip-select range, this signal operates normally.

**$\overline{LCAS}$** —When either bank of DRAM is activated, the  $\overline{LCAS}$  functionality is enabled. The  $\overline{LCAS}$  activates when the DRAM access is for the AD7–AD0 byte.  $\overline{LCAS}$  also activates at the start of a DRAM refresh access.

$\overline{LCAS}$  is three-stated and held resistively High during a bus hold condition. In addition,  $\overline{LCAS}$  has a weak internal pullup resistor that is active during reset.

### **$\overline{MCS3}/\overline{RAS1}/\overline{PIO25}$**

**Midrange Memory Chip Select 3 (output, synchronous, internal pullup)  
Row Address Strobe 1 (output, synchronous)**

**$\overline{MCS3}$** —This pin indicates to the system that a memory access is in progress to the fourth region of the midrange memory block. The base address and size of the mid-range memory block are programmable.  $\overline{MCS3}$  is configured for 8-bit or 16-bit bus size by the auxiliary configuration register.

$\overline{MCS3}$  is three-stated and held resistively High during a bus hold condition. In addition, this pin has a weak internal pullup resistor that is active during reset.

If  $\overline{MCS0}$  is programmed for the entire middle chip-select range, then this signal is available as a PIO or a DRAM control. If  $\overline{MCS3}$  is not programmed as a PIO or DRAM control and if  $\overline{MCS0}$  is programmed for the entire middle chip-select range, this signal operates normally.

**$\overline{RAS1}$** —This pin is the row address strobe for the upper DRAM block. The selection of  $\overline{RAS1}$  or  $\overline{UCS}$  functionality, along with their configurations, are set using the UMCS register. When  $\overline{RAS1}$  is activated, the code activating  $\overline{RAS1}$  must not reside in the  $\overline{UCS}$  memory block. When  $\overline{RAS1}$  is activated,  $\overline{UCS}$  is automatically deactivated and remains negated.

$\overline{RAS1}$  is three-stated and held resistively High during a bus hold condition. In addition,  $\overline{RAS1}$  has a weak internal pullup resistor that is active during reset.

## **NMI**

**Nonmaskable Interrupt (input, synchronous, edge-sensitive)**

This pin indicates to the microcontroller that an interrupt request has occurred. The NMI signal is the highest priority hardware interrupt and, unlike the INT6–INT0 pins, cannot be masked. The microcontroller always transfers program execution to the location specified by the nonmaskable interrupt vector in the microcontroller interrupt vector table when NMI is asserted.

Although NMI is the highest priority interrupt source, it does not participate in the priority resolution process of the maskable interrupts. There is no bit associated with NMI in the interrupt in-service or interrupt request registers. This means that a new NMI request can interrupt an executing NMI interrupt service routine. As with all hardware interrupts, the IF (interrupt flag) is cleared when the processor takes the interrupt, disabling the maskable interrupt sources. However, if maskable interrupts are re-enabled by software in the NMI interrupt service routine, via the STI instruction for example, the fact that an NMI is currently in service does not have any effect on the priority resolution of maskable interrupt requests. For this reason, it is strongly advised that the interrupt service routine for NMI should not enable the maskable interrupts.

An NMI transition from Low to High is latched and synchronized internally, and it initiates the interrupt at the next instruction boundary. To guarantee that the interrupt is recognized, the NMI pin must be asserted for at least one CLKOUTA period.

### **$\overline{PCS1}/\overline{PIO17}$ , $\overline{PCS0}/\overline{PIO16}$**

**Peripheral Chip Selects (output, synchronous)**

These pins indicate to the system that a memory access is in progress to the corresponding region of the peripheral memory block (either I/O or memory address space). The base address of the peripheral memory block is programmable.

The  $\overline{PCS}$  chip selects can overlap either block of DRAM. The  $\overline{PCS}$  chip selects must have the same or greater number of wait states as the bank of DRAM they overlap. The  $\overline{PCS}$  signals take precedence over DRAM accesses when DRAM and memory-mapped peripherals overlap.

$\overline{PCS1}$ – $\overline{PCS0}$  are three-stated and held resistively High during a bus hold condition. In addition,  $\overline{PCS1}$ – $\overline{PCS0}$  each have a weak internal pullup resistor that is active during reset.

Unlike the  $\overline{UCS}$  and  $\overline{LCS}$  chip selects, the  $\overline{PCS}$  outputs assert with the multiplexed AD address bus. Note also that each peripheral chip select asserts over a 256-byte address range, which is twice the address range



covered by peripheral chip selects in the 80C186 and 80C188 microcontrollers.  $\overline{PCS0}$ – $\overline{PCS1}$  also have extended wait state options.

### $\overline{PCS2}/\overline{CTS1}/\overline{ENRX1}/\overline{PIO18}$

**Peripheral Chip Select 2 (output, synchronous)**  
**Clear-to-Send 1 (input, asynchronous)**  
**Enable-Receiver-Request 1 (input, asynchronous)**

$\overline{PCS2}$ —This pin provides the Peripheral Chip Select 2 signal to the system when hardware flow control is not enabled for asynchronous serial port 1. The  $\overline{PCS2}$  signal indicates to the system that a memory access is in progress to the corresponding region of the peripheral memory block (either I/O or memory address space). The base address of the peripheral memory block is programmable.

The  $\overline{PCS}$  chip selects can overlap either block of DRAM. The  $\overline{PCS}$  chip selects must have the same or greater number of wait states as the bank of DRAM they overlap. The  $\overline{PCS}$  signals take precedence over DRAM accesses when DRAM and memory-mapped peripherals overlap.

$\overline{PCS2}$  is three-stated and held resistively High during a bus hold condition. In addition,  $\overline{PCS2}$  has a weak internal pullup resistor that is active during reset.

Unlike the  $\overline{UCS}$  and  $\overline{LCS}$  chip selects, the  $\overline{PCS}$  outputs assert with the multiplexed AD address bus. Note also that each peripheral chip select asserts over a 256-byte address range, which is twice the address range covered by peripheral chip selects in the 80C186 and 80C188 microcontrollers.  $\overline{PCS2}$  also has extended wait state options.

$\overline{CTS1}$ —This pin provides the Clear-to-Send signal for asynchronous serial port 1 when the  $\overline{ENRX1}$  bit in the AUXCON register is 0 and hardware flow control is enabled for the port (FC bit in the serial port 1 control register is set). The  $\overline{CTS1}$  signal gates the transmission of data from the associated serial port transmit register. When  $\overline{CTS1}$  is asserted, the transmitter begins transmission of a frame of data, if any is available. If  $\overline{CTS1}$  is deasserted, the transmitter holds the data in the serial port transmit register. The value of  $\overline{CTS1}$  is checked only at the beginning of the transmission of the frame.

$\overline{ENRX1}$ —This pin provides the Enable Receiver Request for asynchronous serial port 1 when the  $\overline{ENRX1}$  bit in the AUXCON register is 1 and hardware flow control is enabled for the port (FC bit in the serial port 1 control register is set). The  $\overline{ENRX1}$  signal enables the receiver for the associated serial port.

### $\overline{PCS3}/\overline{RTS1}/\overline{RTR1}/\overline{PIO19}$

**Peripheral Chip Select 3 (output, synchronous)**  
**Ready-to-Send 1 (output, asynchronous)**  
**Ready-to-Receive 1 (output, asynchronous)**

$\overline{PCS3}$ —This pin provides the Peripheral Chip Select 3 signal to the system when hardware flow control is not enabled for asynchronous serial port 1. The  $\overline{PCS3}$  signal indicates to the system that a memory access is in progress to the corresponding region of the peripheral memory block (either I/O or memory address space). The base address of the peripheral memory block is programmable.

The  $\overline{PCS}$  chip selects can overlap either block of DRAM. The  $\overline{PCS}$  chip selects must have the same or greater number of wait states as the bank of DRAM they overlap. The  $\overline{PCS}$  signals take precedence over DRAM accesses when DRAM and memory-mapped peripherals overlap.

$\overline{PCS3}$  is three-stated and held resistively High during a bus hold condition. In addition,  $\overline{PCS3}$  has a weak internal pullup resistor that is active during reset.

Unlike the  $\overline{UCS}$  and  $\overline{LCS}$  chip selects, the  $\overline{PCS}$  outputs assert with the multiplexed AD address bus. Note also that each peripheral chip select asserts over a 256-byte address range, which is twice the address range covered by peripheral chip selects in the 80C186 and 80C188 microcontrollers.  $\overline{PCS3}$  also has extended wait state options.

$\overline{RTS1}$ —This pin provides the Ready-to-Send signal for asynchronous serial port 1 when the  $\overline{RTS1}$  bit in the AUXCON register is 1 and hardware flow control is enabled for the port (FC bit in the serial port 1 control register is set). The  $\overline{RTS1}$  signal is asserted when the associated serial port transmit register contains data which has not been transmitted.

$\overline{RTR1}$ —This pin provides the Ready-to-Receive signal for asynchronous serial port 1 when the  $\overline{RTS1}$  bit in the AUXCON register is 0 and hardware flow control is enabled for the port (FC bit in the serial port 1 control register is set). The  $\overline{RTR1}$  signal is asserted when the associated serial port receive register does not contain valid, unread data.

### $\overline{PCS5}/\overline{A1}/\overline{PIO3}$

**Peripheral Chip Select 5 (output, synchronous)**  
**Latched Address Bit 1 (output, synchronous)**

$\overline{PCS5}$ —This pin indicates to the system that a memory access is in progress to the sixth region of the peripheral memory block (either I/O or memory address space). The base address of the peripheral memory block is programmable.

The  $\overline{PCS}$  chip selects can overlap either block of DRAM. The  $\overline{PCS}$  chip selects must have the same or greater number of wait states as the bank of DRAM

they overlap. The  $\overline{PCS}$  signals take precedence over DRAM accesses when DRAM and memory-mapped peripherals overlap.

$\overline{PCS5}$  is three-stated and held resistively High during a bus hold condition. In addition,  $\overline{PCS5}$  has a weak internal pullup resistor that is active during reset.

Unlike the  $\overline{UCS}$  and  $\overline{LCS}$  chip selects, the  $\overline{PCS}$  outputs assert with the multiplexed AD address bus. Note also that each peripheral chip select asserts over a 256-byte address range, which is twice the address range covered by peripheral chip selects in the 80C186 and 80C188 microcontrollers.  $\overline{PCS5}$  also has extended wait state options.

**A1**—When the EX bit in the  $\overline{MCS}$  and  $\overline{PCS}$  auxiliary register is 0, this pin supplies an internally latched address bit 1 to the system. During a bus hold condition, A1 retains its previously latched value.

### $\overline{PCS6/A2/PIO2}$

**Peripheral Chip Select 6 (output, synchronous)  
Latched Address Bit 2 (output, synchronous)**

$\overline{PCS6}$ —This pin indicates to the system that a memory access is in progress to the seventh region of the peripheral memory block (either I/O or memory address space). The base address of the peripheral memory block is programmable.

The  $\overline{PCS}$  chip selects can overlap either block of DRAM. The  $\overline{PCS}$  chip selects must have the same or greater number of wait states as the bank of DRAM they overlap. The  $\overline{PCS}$  signals take precedence over DRAM accesses when DRAM and memory-mapped peripherals overlap.

$\overline{PCS6}$  is three-stated and held resistively High during a bus hold condition. In addition,  $\overline{PCS6}$  has a weak internal pullup resistor that is active during reset.

Unlike the  $\overline{UCS}$  and  $\overline{LCS}$  chip selects, the  $\overline{PCS}$  outputs assert with the multiplexed AD address bus. Note also that each peripheral chip select asserts over a 256-byte address range, which is twice the address range covered by peripheral chip selects in the 80C186 and 80C188 microcontrollers.  $\overline{PCS6}$  also has extended wait state options.

**A2**—When the EX bit in the  $\overline{MCS}$  and  $\overline{PCS}$  auxiliary register is 0, this pin supplies an internally latched address bit 2 to the system. During a bus hold condition, A2 retains its previously latched value.

### PIO31–PIO0 (Shared)

**Programmable I/O Pins (input/output,  
asynchronous, open-drain)**

The Am186ED/EDLV microcontrollers provide 32 individually programmable I/O pins. Each PIO can be programmed with the following attributes: PIO function (enabled/disabled), direction (input/output), and weak

pullup or pulldown. The pins that are multiplexed with PIO31–PIO0 are listed in Table 2 and Table 3.

After power-on reset, the PIO pins default to various configurations. The column titled *Power-On Reset Status* in Table 2 and Table 3 lists the defaults for the PIOs. Most of the PIO pins are configured as PIO inputs with pullup after power-on reset. The system initialization code must reconfigure any PIO pins as required.

The A19–A17 address pins default to normal operation on power-on reset, allowing the processor to correctly begin fetching instructions at the boot address FFFF0h. The  $\overline{DT/R}$ ,  $\overline{DEN}$ , and SRDY pins also default to normal operation on power-on reset. PIO15 and PIO24 should be set to normal operation before enabling either bank of DRAM. PIO25 should be set to normal operation before enabling the upper bank of DRAM.

### $\overline{RD}$

**Read Strobe (output, synchronous, three-state)**

$\overline{RD}$ —This pin indicates to the system that the microcontroller is performing a memory or I/O read cycle.  $\overline{RD}$  is guaranteed to not be asserted before the address and data bus is floated during the address-to-data transition.  $\overline{RD}$  floats during a bus hold condition.

### $\overline{RES}$

**Reset (input, asynchronous, level-sensitive)**

This pin requires the microcontroller to perform a reset. When  $\overline{RES}$  is asserted, the microcontroller immediately terminates its present activity, clears its internal logic, and transfers CPU control to the reset address, FFFF0h.

$\overline{RES}$  must be held Low for at least 1 ms.

$\overline{RES}$  can be asserted asynchronously to CLKOUTA because  $\overline{RES}$  is synchronized internally. For proper initialization,  $V_{CC}$  must be within specifications, and CLKOUTA must be stable for more than four CLKOUTA periods during which  $\overline{RES}$  is asserted.

The microcontroller begins fetching instructions approximately 6.5 CLKOUTA periods after  $\overline{RES}$  is deasserted. This input is provided with a Schmitt trigger to facilitate power-on  $\overline{RES}$  generation via an RC network.

Table 2. Numeric PIO Pin Designations

PIO No	Associated Pin	Power-On Reset Status
0	TMRIN1	Input with pullup
1	TMROUT1	Input with pulldown
2	$\overline{\text{PCS6/A2}}$	Input with pullup
3	$\overline{\text{PCS5/A1}}$	Input with pullup
4	$\text{DT}/\overline{\text{R}}$	Normal operation <sup>(3)</sup>
5	$\overline{\text{DEN/DS}}$	Normal operation <sup>(3)</sup>
6	SRDY	Normal operation <sup>(4)</sup>
7 <sup>(1)</sup>	A17	Normal operation <sup>(3)</sup>
8 <sup>(1)</sup>	A18	Normal operation <sup>(3)</sup>
9 <sup>(1)</sup>	A19	Normal operation <sup>(3)</sup>
10	TMROUT0	Input with pulldown
11	TMRIN0	Input with pullup
12	DRQ0/INT5	Input with pullup
13	DRQ1/INT6	Input with pullup
14	$\overline{\text{MCS0}}$	Input with pullup
15	$\overline{\text{MCS1/UCAS}}$	Input with pullup
16	$\overline{\text{PCS0}}$	Input with pullup
17	$\overline{\text{PCS1}}$	Input with pullup
18	$\overline{\text{PCS2/CTS1/ENRX1}}$	Input with pullup
19	$\overline{\text{PCS3/RTS1/RTR1}}$	Input with pullup
20	$\overline{\text{RTS0/RTR0}}$	Input with pullup
21	$\overline{\text{CTS0/ENRX0}}$	Input with pullup
22	TXD0	Input with pullup
23	RXD0	Input with pullup
24	$\overline{\text{MCS2/LCAS}}$	Input with pullup
25	$\overline{\text{MCS3/RAS1}}$	Input with pullup
26 <sup>(1,2)</sup>	$\overline{\text{UZI}}$	Input with pullup
27	TXD1	Input with pullup
28	RXD1	Input with pullup
29 <sup>(1,2)</sup>	S6/CLKDIV2	Input with pullup
30	INT4	Input with pullup
31	INT2/INTA0/PWD	Input with pullup

Table 3. Alphabetic PIO Pin Designations

Associated Pin	PIO No	Power-On Reset Status
A17 <sup>(1)</sup>	7	Normal operation <sup>(3)</sup>
A18 <sup>(1)</sup>	8	Normal operation <sup>(3)</sup>
A19 <sup>(1)</sup>	9	Normal operation <sup>(3)</sup>
$\overline{\text{CTS0/ENRX0}}$	21	Input with pullup
$\overline{\text{DEN/DS}}$	5	Normal operation <sup>(3)</sup>
DRQ0/INT5	12	Input with pullup
DRQ1/INT6	13	Input with pullup
$\text{DT}/\overline{\text{R}}$	4	Normal operation <sup>(3)</sup>
INT2/INTA0/PWD	31	Input with pullup
INT4	30	Input with pullup
$\overline{\text{MCS0}}$	14	Input with pullup
$\overline{\text{MCS1/UCAS}}$	15	Input with pullup
$\overline{\text{MCS2/LCAS}}$	24	Input with pullup
$\overline{\text{MCS3/RAS1}}$	25	Input with pullup
$\overline{\text{PCS0}}$	16	Input with pullup
$\overline{\text{PCS1}}$	17	Input with pullup
$\overline{\text{PCS2/CTS1/ENRX1}}$	18	Input with pullup
$\overline{\text{PCS3/RTS1/RTR1}}$	19	Input with pullup
$\overline{\text{PCS5/A1}}$	3	Input with pullup
$\overline{\text{PCS6/A2}}$	2	Input with pullup
$\overline{\text{RTS0/RTR0}}$	20	Input with pullup
RXD0	23	Input with pullup
RXD1	28	Input with pullup
S6/CLKDIV2 <sup>(1,2)</sup>	29	Input with pullup
SRDY	6	Normal operation <sup>(4)</sup>
TMRIN0	11	Input with pullup
TMRIN1	0	Input with pullup
TMROUT0	10	Input with pulldown
TMROUT1	1	Input with pulldown
TXD0	22	Input with pullup
TXD1	27	Input with pullup
$\overline{\text{UZI}}$ <sup>(1,2)</sup>	26	Input with pullup

**Notes:**

The following notes apply to both tables.

1. These pins are used by many emulators. (Emulators also use  $\overline{\text{S2-S0}}$ ,  $\overline{\text{RES}}$ , NMI, CLKOUTA,  $\overline{\text{BHE}}$ , ALE, AD15–AD0, and A16–A0.)
2. These pins revert to normal operation if  $\overline{\text{BHE/ADEN}}$  is held Low during power-on reset.
3. When used as a PIO, input with pullup option available.
4. When used as a PIO, input with pulldown option available.



**RTS0/RTR0/PIO20**

**Ready-to-Send 0 (output, asynchronous)**  
**Ready-to-Receive 0 (output, asynchronous)**

**RTS0**—This pin provides the Ready-to-Send signal for asynchronous serial port 0 when the  $\overline{\text{RTS0}}$  bit in the AUXCON register is 1 and hardware flow control is enabled for the port (FC bit in the serial port 0 control register is set). The  $\overline{\text{RTS0}}$  signal is asserted when the associated serial port transmit register contains data that has not been transmitted.

**RTR0**—This pin provides the Ready-to-Receive signal for asynchronous serial port 0 when the  $\overline{\text{RTS0}}$  bit in the AUXCON register is 0 and hardware flow control is enabled for the port (FC bit in the serial port 0 control register is set). The  $\overline{\text{RTR0}}$  signal is asserted when the associated serial port receive register does not contain valid, unread data.

**RXD0/PIO23**

**Receive Data 0 (input, asynchronous)**

This pin supplies asynchronous serial receive data from the system to asynchronous serial port 0.

**RXD1/PIO28**

**Receive Data 1 (input, asynchronous)**

This pin supplies asynchronous serial receive data from the system to asynchronous serial port 1.

 **$\overline{\text{S2}}/\text{BTSEL}$** 

**Bus Cycle Status (output, three-state, synchronous)**  
**Boot Mode Select**

**$\overline{\text{S2}}$** —This pin indicates to the system the type of bus cycle in progress.  $\overline{\text{S2}}$  can be used as a logical memory or I/O indicator.  $\overline{\text{S2}}\text{--}\overline{\text{S0}}$  float during bus hold and hold acknowledge conditions. The  $\overline{\text{S2}}\text{--}\overline{\text{S0}}$  pins are encoded as shown in Table 4.

**BTSEL**—The Am186ED/EDLV microcontrollers can boot from 8- or 16-bit wide nonvolatile memory, based on the state of the BTSEL pin. If BTSEL is pulled High or left floating, an internal pullup sets the boot mode option to 16-bit. If BTSEL is pulled resistively Low during reset, the 8-bit boot mode option is selected. The status of the BTSEL pin is latched on the rising edge of reset. If 8-bit mode is selected, the width of the memory region associated with  $\overline{\text{UCS}}$  can be changed in the AUXCON register.

This signal should never be tied to  $V_{\text{CC}}$  or  $V_{\text{SS}}$  directly since this pin is driven during normal operation. This signal should be tied Low with an external resistor if the 8-bit boot mode is to be used. The internal pullup resistor on BTSEL is ~9 kohm.

 **$\overline{\text{S1}}\text{--}\overline{\text{S0}}$** 

**Bus Cycle Status (output, three-state, synchronous)**

These pins indicate to the system the type of bus cycle in progress.  $\overline{\text{S1}}$  can be used as a data transmit or receive indicator.  $\overline{\text{S1}}\text{--}\overline{\text{S0}}$  float during bus hold and hold acknowledge conditions. The  $\overline{\text{S2}}\text{--}\overline{\text{S0}}$  pins are encoded as shown in Table 4.

**Table 4. Bus Cycle Encoding**

$\overline{\text{S2}}/\text{BTSEL}$	$\overline{\text{S1}}$	$\overline{\text{S0}}$	Bus Cycle
0	0	0	Interrupt acknowledge
0	0	1	Read data from I/O
0	1	0	Write data to I/O
0	1	1	Halt
1	0	0	Instruction fetch
1	0	1	Read data from memory
1	1	0	Write data to memory
1	1	1	None (passive)

 **$\text{S6}/\overline{\text{CLKDIV2}}/\text{PIO29}$** 

**Bus Cycle Status Bit 6 (output, synchronous)**  
**Clock Divide by 2 (input, internal pullup)**

**$\text{S6}$** —During the second and remaining periods of a cycle ( $t_2$ ,  $t_3$ , and  $t_4$ ), this pin is asserted High to indicate a DMA-initiated bus cycle. During a bus hold or reset condition,  $\text{S6}$  floats.

**$\overline{\text{CLKDIV2}}$** —If  $\text{S6}/\overline{\text{CLKDIV2}}/\text{PIO29}$  is held Low during power-on reset, the chip enters clock divided by 2 mode where the processor clock is derived by dividing the external clock input by 2. If this mode is selected, the PLL is disabled. The pin is sampled on the rising edge of  $\overline{\text{RES}}$ .

If  $\text{S6}$  is to be used as PIO29 in input mode, the device driving PIO29 must not drive the pin Low during power-on reset.  $\text{S6}/\overline{\text{CLKDIV2}}/\text{PIO29}$  defaults to a PIO input with pullup, so the pin does not need to be driven High externally.

**SRDY/PIO6**

**Synchronous Ready (input, synchronous, level-sensitive)**

This pin indicates to the microcontroller that the addressed memory space or I/O device will complete a data transfer. The SRDY pin accepts an active High input synchronized to CLKOUTA.

Using SRDY instead of ARDY allows a relaxed system timing because of the elimination of the one-half clock period required to internally synchronize ARDY. To always assert the ready condition to the

microcontroller, tie SRDY High. If the system does not use SRDY, tie the pin Low to yield control to ARDY.

### TMRIN0/PIO11

#### Timer Input 0 (input, synchronous, edge-sensitive)

This pin supplies a clock or control signal to the internal microcontroller timer 0. After internally synchronizing a Low-to-High transition on TMRIN0, the microcontroller increments the timer. TMRIN0 must be tied High if not being used. When PIO11 is enabled, TMRIN0 is pulled High internally.

TMRIN0 is driven internally by INT2/ $\overline{\text{INTA0}}$ /PWD when pulse width demodulation mode is enabled. The TMRIN0/PIO11 pin can be used as a PIO when pulse width demodulation mode is enabled.

### TMRIN1/PIO0

#### Timer Input 1 (input, synchronous, edge-sensitive)

This pin supplies a clock or control signal to the internal microcontroller timer 1. After internally synchronizing a Low-to-High transition on TMRIN1, the microcontroller increments the timer. TMRIN1 must be tied High if not being used. When PIO0 is enabled, TMRIN1 is pulled High internally.

TMRIN1 is driven internally by INT2/ $\overline{\text{INTA0}}$ /PWD when pulse width demodulation mode is enabled. The TMRIN1/PIO0 pin can be used as a PIO when pulse width demodulation mode is enabled.

### TMROUT0/PIO10

#### Timer Output 0 (output, synchronous)

This pin supplies the system with either a single pulse or a continuous waveform with a programmable duty cycle. TMROUT0 is floated during a bus hold or reset.

### TMROUT1/PIO1

#### Timer Output 1 (output, synchronous)

This pin supplies the system with either a single pulse or a continuous waveform with a programmable duty cycle. TMROUT1 floats during a bus hold or reset.

### TXD0/PIO22

#### Transmit Data 0 (output, asynchronous)

This pin supplies asynchronous serial transmit data to the system from serial port 0.

### TXD1/PIO27

#### Transmit Data 1 (output, asynchronous)

This pin supplies asynchronous serial transmit data to the system from serial port 1.

### UCS/ONCE1

#### Upper Memory Chip Select (output, synchronous) ONCE Mode Request 1 (input, internal pullup)

$\overline{\text{UCS}}$ —This pin indicates to the system that a memory access is in progress to the upper memory block. The base address and size of the upper memory block are programmable up to 512 Kbytes.

$\overline{\text{UCS}}$  is three-stated and held resistively High during a bus hold condition. In addition,  $\overline{\text{UCS}}$  has an  $\sim 9\text{-k}\Omega$  internal pullup resistor that is active during reset.

After reset,  $\overline{\text{UCS}}$  is active for the 64 Kbyte memory range from F0000h to FFFFFh, including the reset address of FFFF0h.

When  $\overline{\text{RAS1}}$  is activated, the code activating  $\overline{\text{RAS1}}$  must not reside in the  $\overline{\text{UCS}}$  memory block. When  $\overline{\text{RAS1}}$  is activated,  $\overline{\text{UCS}}$  is automatically deactivated and remains negated. This allows code to boot from  $\overline{\text{UCS}}$ , copy its code to another memory device, then activate a DRAM bank in place of the  $\overline{\text{UCS}}$  memory block.

**ONCE1**—During reset, this pin and  $\overline{\text{LCS/ONCE0}}$  indicate to the microcontroller the mode in which it should operate.  $\overline{\text{ONCE0}}$  and  $\overline{\text{ONCE1}}$  are sampled on the rising edge of  $\overline{\text{RES}}$ . If both pins are asserted Low, the microcontroller enters ONCE mode. Otherwise, it operates normally. In ONCE mode, all pins assume a high-impedance state and remain in that state until a subsequent reset occurs. To guarantee that the microcontroller does not inadvertently enter ONCE mode,  $\overline{\text{ONCE1}}$  has a weak internal pullup resistor that is active only during a reset.

### UZI/PIO26

#### Upper Zero Indicate (output, synchronous)

This pin lets the designer determine if an access to the interrupt vector table is in progress by ORing it with bits 15–10 of the address and data bus (AD15–AD10).  $\overline{\text{UZI}}$  is the logical AND of the inverted A19–A16 bits. It asserts in the first period of a bus cycle and is held throughout the cycle.

### V<sub>CC</sub>

#### Power Supply (input)

These pins supply power (+5 V) to the microcontroller.

### WHB

#### Write High Byte (output, three-state, synchronous)

This pin and  $\overline{\text{WLB}}$  indicate to the system which bytes of the data bus (upper, lower, or both) participate in a write cycle. In 80C186 microcontroller designs, information is provided by  $\overline{\text{BHE}}$ ,  $\text{AD0}$ , and  $\overline{\text{WR}}$ . However, by using  $\overline{\text{WHB}}$  and  $\overline{\text{WLB}}$ , the standard system interface logic and external address latch that were required are eliminated.

$\overline{WHB}$  is asserted with AD15–AD8.  $\overline{WHB}$  is the logical OR of  $\overline{BHE}$  and  $\overline{WR}$ . This pin floats during reset.

## **$\overline{WLB}$**

### **Write Low Byte (output, three-state, synchronous)**

$\overline{WLB}$ —This pin and  $\overline{WHB}$  indicate to the system which bytes of the data bus (upper, lower, or both) participate in a write cycle. In 80C186 microcontroller designs, this information is provided by  $\overline{BHE}$ , AD0, and  $\overline{WR}$ . However, by using  $\overline{WHB}$  and  $\overline{WLB}$ , the standard system interface logic and external address latch that were required are eliminated.

$\overline{WLB}$  is asserted with AD7–AD0.  $\overline{WLB}$  is the logical OR of AD0 and  $\overline{WR}$ . This pin floats during reset.

## **$\overline{WR}$**

### **Write Strobe (output, synchronous)**

$\overline{WR}$ —This pin indicates to the system that the data on the bus is to be written to a memory or I/O device.  $\overline{WR}$  floats during a bus hold or reset condition.  $\overline{WR}$  should be used for DRAM write enable.

## **X1**

### **Crystal Input (input)**

This pin and the X2 pin provide connections for a fundamental mode or third-overtone, parallel-resonant crystal used by the internal oscillator circuit. To provide the microcontroller with an external clock source, connect the source to the X1 pin and leave the X2 pin unconnected.

## **X2**

### **Crystal Output (output)**

This pin and the X1 pin provide connections for a fundamental mode or third-overtone, parallel-resonant crystal used by the internal oscillator circuit. To provide the microcontroller with an external clock source, leave the X2 pin unconnected and connect the source to the X1 pin.

## FUNCTIONAL DESCRIPTION

The Am186ED/EDLV microcontrollers are based on the architecture of the 80C186 and 80C188 microcontrollers. The Am186ED/EDLV microcontrollers function in the enhanced mode of earlier generations of 80C186 and 80C188 microcontrollers. Enhanced mode includes system features such as power-save control.

Each of the 8086, 8088, 80186, and 80188 microcontrollers contains the same basic set of registers, instructions, and addressing modes. The Am186ED/EDLV microcontrollers are backward-compatible with the 80C186 and 80C188 microcontrollers.

A full description of all the Am186ED/EDLV microcontroller registers and instructions is included in the *Am186ED/EDLV Microcontrollers User's Manual*, order# 21335A.

### Memory Organization

Memory is organized in sets of segments. Each segment is a linear contiguous sequence of 64K (2<sup>16</sup>) 8-bit bytes. Memory is addressed using a two-component address that consists of a 16-bit segment value and a 16-bit offset. The 16-bit segment values are contained in one of four internal segment registers (CS, DS, SS, or ES). The physical address is calculated by shifting the segment value left by 4 bits and adding the 16-bit offset value to yield a 20-bit physical address (see Figure 3). This allows for a 1-Mbyte physical address size.

All instructions that address operands in memory must specify the segment value and the 16-bit offset value. For speed and compact instruction encoding, the seg-

ment register used for physical address generation is implied by the addressing mode used (see Table 5).

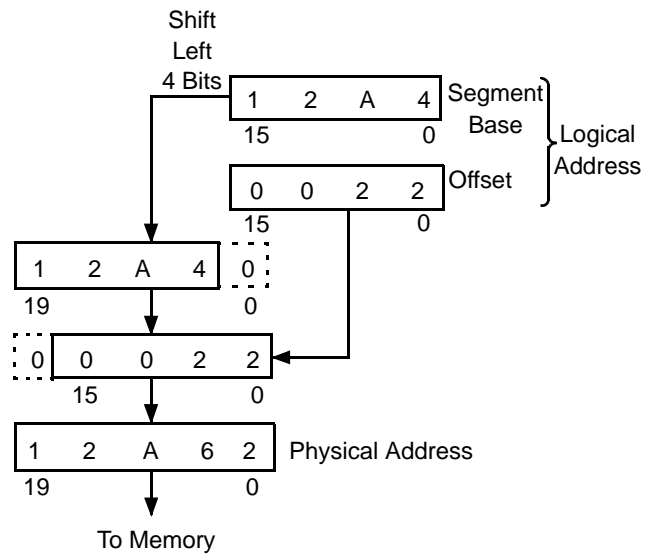

**Figure 3. Two-Component Address**

### I/O Space

The I/O space consists of 64K 8-bit or 32K 16-bit ports. Separate instructions (IN, INS and OUT, OUTS) address the I/O space with either an 8-bit port address specified in the instruction, or a 16-bit port address in the DX register. Eight-bit port addresses are zero-extended such that A15–A8 are Low. I/O port addresses 00F8h through 00FFh are reserved.

**Table 5. Segment Register Selection Rules**

Memory Reference Needed	Segment Register Used	Implicit Segment Selection Rule
Instructions	Code (CS)	Instructions (including immediate data)
Local Data	Data (DS)	All data references
Stack	Stack (SS)	All stack pushes and pops; any memory references that use BP Register
External Data (Global)	Extra (ES)	All string instruction references that use the DI Register as an index

**BUS OPERATION**

The industry-standard 80C186 and 80C188 microcontrollers use a multiplexed address and data (AD) bus. The address is present on the AD bus only during the  $t_1$  clock phase. The Am186ED/EDLV microcontrollers continue to provide the multiplexed AD bus and, in addition, provides a nonmultiplexed address (A) bus. The A bus provides an address to the system for the complete bus cycle ( $t_1$ – $t_4$ ).

For systems where power consumption is a concern, it is possible to disable the address from being driven on the AD bus during the normal address portion of the bus cycle for accesses to  $\overline{RAS0}$ ,  $\overline{RAS1}$ ,  $\overline{UCS}$ , and/or  $\overline{LCS}$  address spaces. In this mode, the affected bus is placed in a high-impedance state during the address portion of the bus cycle. This feature is enabled through the DA bits in the UMCS and LMCS registers. When address disable is in effect, the number of signals that assert on the bus during all normal bus cycles to the associated address space is reduced, decreasing power consumption and reducing processor switching noise. In 8-bit mode, the address is driven on AD15–AD8 during the data portion of the bus cycle regardless of the setting of the DA bits.

If the  $\overline{ADEN}$  pin is pulled Low during processor reset, the value of the DA bits in the UMCS and LMCS registers is ignored and the address is driven on the AD bus

for all accesses, thus preserving the industry-standard 80C186 and 80C188 microcontrollers' multiplexed address bus and providing support for existing emulation tools.

The following diagrams show the bus cycles of the Am186ED/EDLV microcontrollers when the address bus disable feature is in effect:

Figure 4 shows the affected signals during a normal read or write operation for 16-bit mode. The address and data are multiplexed onto the AD bus.

Figure 5 shows a 16-bit mode bus cycle when address bus disable is in effect. This results in the AD bus operating in a nonmultiplexed address/data mode. The A bus has the address during a read or write operation.

Figure 6 shows the affected signals during a normal read or write operation for 8-bit mode. The multiplexed address/data mode is compatible with the 80C186 and 80C188 microcontrollers and might be used to take advantage of existing logic or peripherals.

Figure 7 shows an 8-bit mode bus cycle when address bus disable is in effect. The address and data are not multiplexed. The AD7–AD0 signals have only data on the bus, while the AD bus has the address during a read or write operation.

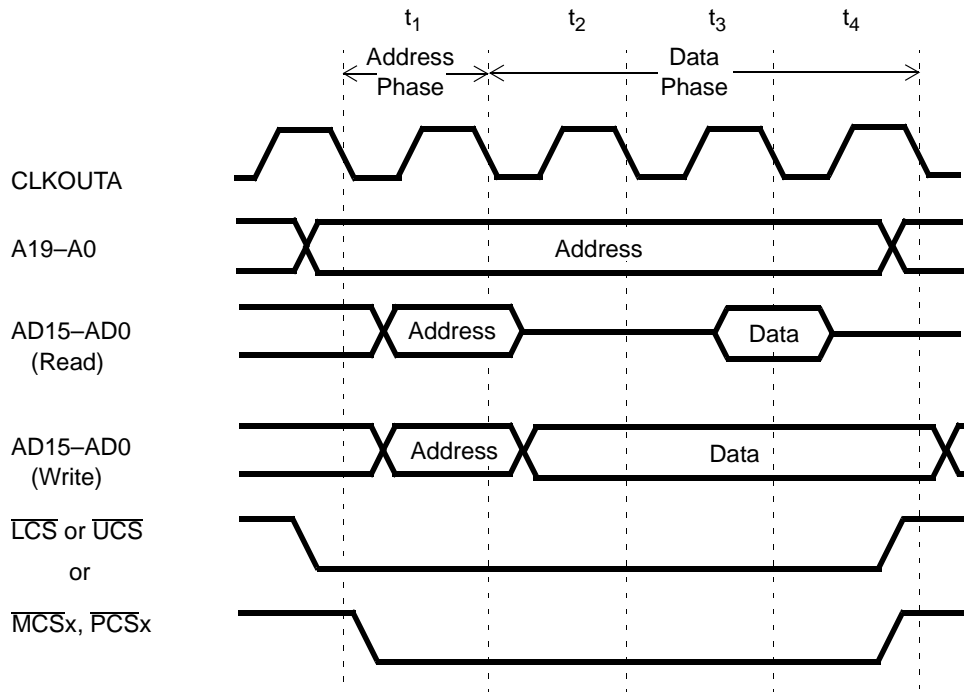

**Note:** For a detailed description of DRAM control signals, see DRAM switching characteristics beginning on page 70.

**Figure 4. 16-Bit Mode—Normal Read and Write Operation**

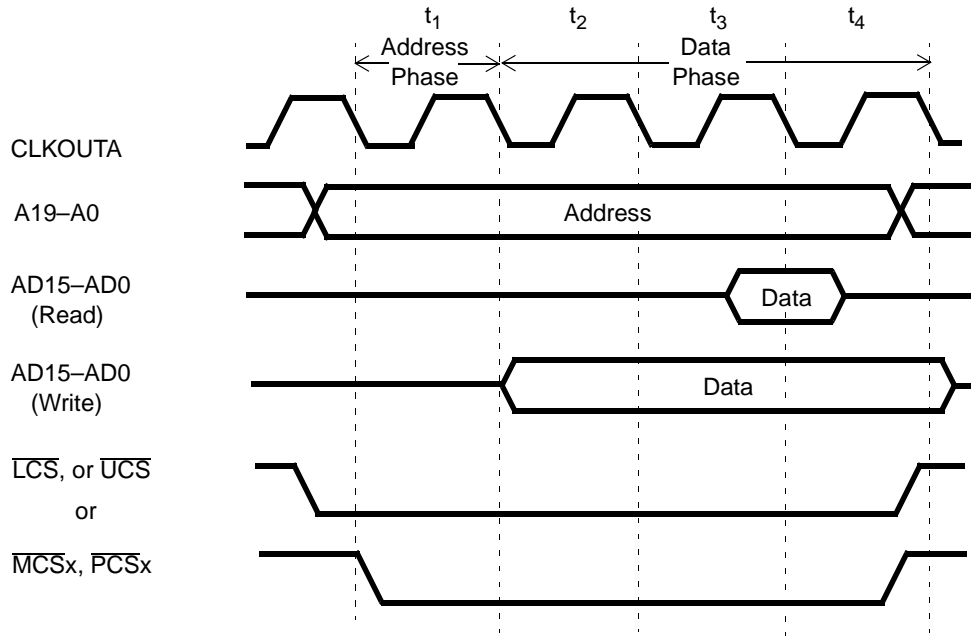

**Note:** For a detailed description of DRAM control signals, see DRAM switching characteristics beginning on page 70.

**Figure 5. 16-Bit Mode—Read and Write with Address Bus Disable In Effect**

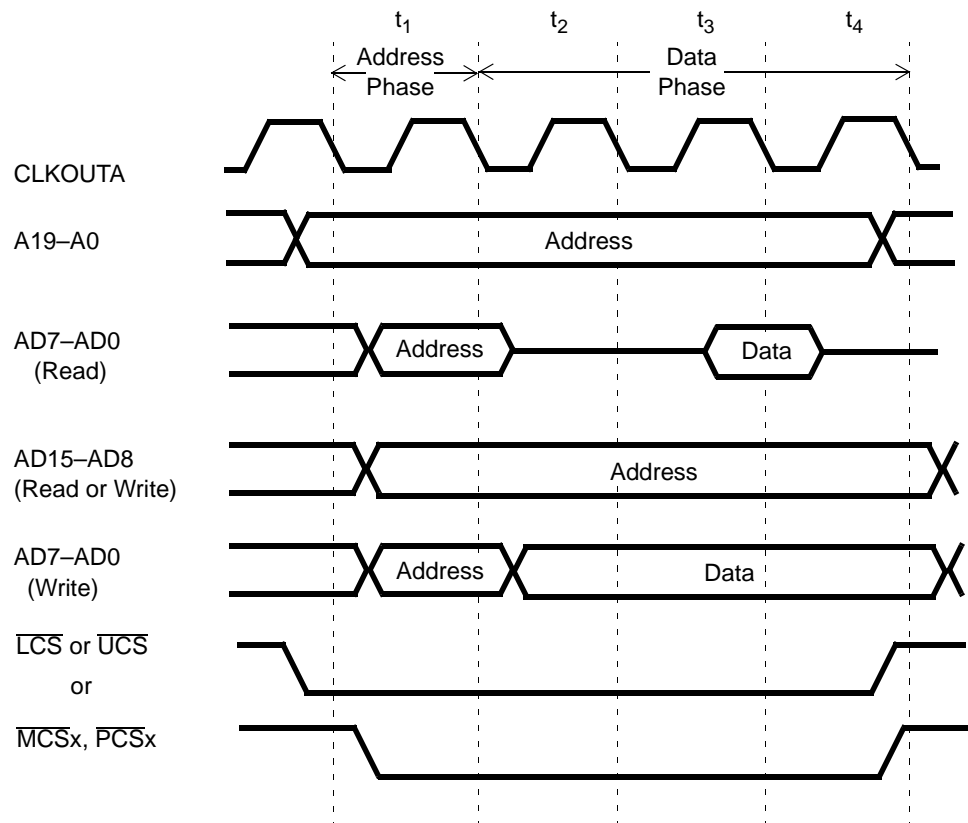

**Figure 6. 8-Bit Mode—Normal Read and Write Operation**



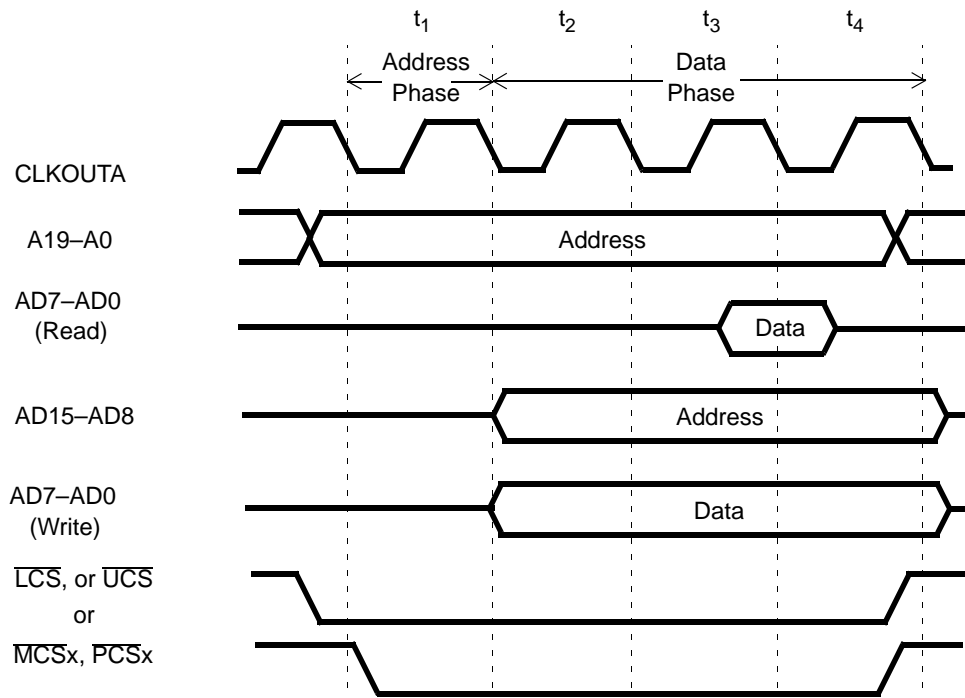

Figure 7. 8-Bit Mode—Read and Write with Address Bus Disable in Effect

## BUS INTERFACE UNIT

The bus interface unit controls all accesses to external peripherals and memory devices. External accesses include those to memory devices, as well as those to memory-mapped and I/O-mapped peripherals and the peripheral control block. The Am186ED/EDLV microcontrollers provide an enhanced bus interface unit with the following features:

- A nonmultiplexed address bus
- DRAM address multiplexing
- A static bus-sizing option for 8-bit and 16-bit memory and I/O
- Separate byte write enables and  $\overline{\text{CAS}}$  for High and Low bytes
- Data strobe bus interface option

The standard 80C186/188 microcontroller multiplexed address and data bus requires system interface logic and an external address latch. On the Am186ED/EDLV microcontrollers, new byte write enables, DRAM control logic, and a new nonmultiplexed address bus can reduce design costs by eliminating this external logic.

The standard 80C186/188 microcontroller required external DRAM controller logic and DRAM address multiplex circuitry for interfacing to DRAM. On the Am186ED/EDLV microcontrollers, the integrated DRAM controller and internal address multiplexing can reduce design costs by eliminating this external logic.

Further, system costs can be reduced for systems using more than 64K of RAM by replacing SRAM with less expensive DRAM.

### Nonmultiplexed Address Bus

The nonmultiplexed address bus (A19-A0) is valid one-half CLKOUTA cycle in advance of the address on the AD bus. When used in conjunction with the modified  $\overline{\text{UCS}}$  and  $\overline{\text{LCS}}$  outputs and the byte-write enable signals, the A19-A0 bus provides a seamless interface to SRAM, and Flash EPROM memory systems.

### DRAM Address Multiplexing

The A19-A0 address bus also provides the addresses for the DRAM. When  $\overline{\text{RAS0}}$  or  $\overline{\text{RAS1}}$  asserts for a read or write, all the address signals are valid. This allows the DRAM to latch the odd addresses into the row address. Before the  $\overline{\text{UCAS}}$  and/or  $\overline{\text{LCAS}}$  asserts, the odd addresses A17-A1 change to reflect the even addresses. This allows the DRAM to latch in the even addresses into the column address. During a refresh cycle, the entire A19-A0 address bus is stable but undefined. The internal address and that reflected on the AD bus is all 1s. The DRAM pin interface is shown in Table 6.



Table 6. DRAM Pin Interface

AM186ED/EDLV Microcontroller Pins	DRAM Pin
A1	MA0
A3	MA1
A5	MA2
A7	MA3
A9	MA4
A11	MA5
A13	MA6
A15	MA7
A17	MA8
$\overline{\text{RAS0}}$	$\overline{\text{RAS}}$ (Bank 0)
$\overline{\text{RAS1}}$	$\overline{\text{RAS}}$ (Bank 1)
$\overline{\text{UCAS}}$	$\overline{\text{UCAS}}$ (AD15–AD8 Byte)
$\overline{\text{LCAS}}$	$\overline{\text{LCAS}}$ (AD7–AD0 Byte)
$\overline{\text{RD}}$	$\overline{\text{OE}}$
$\overline{\text{WR}}$	$\overline{\text{WE}}$

### Programmable Bus Sizing

The Am186ED/EDLV microcontrollers allow programmability for data bus widths through fields in the Auxiliary Configuration Register (AUXCON), as shown in Table 7. The USIZ bit in AUXCON is only configurable if the boot mode is 8-bit at reset.

The width of the data access should not be modified while the processor is fetching instructions from the associated address space.

Table 7. Programming the Bus Width of Am186ED/EDLV Microcontrollers

Space	AUXCON Field	Value	Bus Width	Comments
$\overline{\text{UCS}}$	USIZ	0	16 bits	Dependent on boot option <sup>1</sup>
		1	8 bits	
$\overline{\text{LCS}}$	LSIZ	0	16 bits	Default
		1	8 bits	
I/O	IOSIZ	0	16 bits	Default
		1	8 bits	
Other	MSIZ	0	16 bits	Default
		1	8 bits	

#### Note:

- $\overline{\text{UCS}}$  width on reset is determined by the  $\overline{\text{S2/BTSEL}}$  pin. If  $\overline{\text{UCS}}$  boots as a 16-bit space, it is not re-configurable to 8-bit.

### Byte-Write Enables

The Am186ED/EDLV microcontrollers provide the  $\overline{\text{WHB}}$  (Write High Byte) and  $\overline{\text{WLB}}$  (Write Low Byte) signals, which act as byte-write enables.

$\overline{\text{WHB}}$  is the logical OR of  $\overline{\text{BHE}}$  and  $\overline{\text{WR}}$ .  $\overline{\text{WHB}}$  is Low when  $\overline{\text{BHE}}$  and  $\overline{\text{WR}}$  are both Low.  $\overline{\text{WLB}}$  is the logical OR of A0 and  $\overline{\text{WR}}$ .  $\overline{\text{WLB}}$  is Low when A0 and  $\overline{\text{WR}}$  are both Low.

The byte-write enables are driven in conjunction with the nonmultiplexed address bus as required for the write timing requirements of common SRAMs.

### Data Strobe Bus Interface Option

The Am186ED/EDLV microcontrollers provide an asynchronous bus interface that allows the use of 68K-type peripherals. This implementation combines a  $\overline{\text{DS}}$  data strobe signal (multiplexed with  $\overline{\text{DEN}}$ ) with an asynchronous ARDY ready input. When  $\overline{\text{DS}}$  is asserted, the data and address signals are valid.

A chip select signal, ARDY,  $\overline{\text{DS}}$ , and other control signals ( $\overline{\text{RD}}/\overline{\text{WR}}$ ) can control the interface of 68K-type external peripherals to the AD bus.

### DRAM INTERFACE

The Am186ED/EDLV microcontrollers support up to two banks of DRAM. The use of DRAM can significantly reduce the memory costs for applications using more than 64K of RAM. No performance is lost except for the slight overhead of periodically refreshing the DRAM. The lower bank of DRAM uses the  $\overline{\text{LCS}}$  space. The upper bank of DRAM uses the  $\overline{\text{UCS}}$  space. Either, neither, or both banks can be activated. When either bank is activated, the  $\overline{\text{UCAS}}$  and  $\overline{\text{LCAS}}$  are enabled, and the DRAM address multiplexing is enabled on the A19–A0 bus. When DRAM is activated, the corresponding memory bus size should be set to 16-bit. The use of 8-bit-wide DRAM is not supported. All refreshes to DRAM are 7 clocks long. The refreshes must be separately enabled in the RCU.

The improved memory timing specifications of the Am186ED/EDLV microcontrollers allow for zero-wait-state operation using 50-ns DRAM at a 40-MHz clock speed. 60-ns DRAM requires one wait state at 40 MHz and zero wait states at 33 MHz and below. 70-ns DRAM requires two wait states at 40 MHz, one wait state at 33 MHz, and zero wait states at 25 MHz and below. This reduces overall system cost by enabling the use of commonly available memory speeds and taking advantage of DRAM's lower cost per bit over SRAM.

## PERIPHERAL CONTROL BLOCK

The integrated peripherals of the Am186ED/EDLV microcontrollers are controlled by 16-bit read/write registers. The peripheral registers are contained within an internal 256-byte peripheral control block (PCB). The registers are physically located in the peripheral devices they control, but they are addressed as a single 256-byte block. Table 8 shows a map of these registers.

### Reading and Writing the PCB

Code written for the Am186ED/EDLV microcontrollers should perform all writes to the PCB registers as byte writes. These writes transfer 16 bits of data to the PCB register even if an 8-bit register is named in the instruction. For example, `out dx, al` results in the value of `ax` being written to the port address in `dx`. Reads to the PCB should be done as word reads. Code written in this manner runs correctly on the Am186ED/EDLV microcontrollers with the PCB overlaid on either 8- or 16-bit address spaces.

Unaligned reads and writes to the PCB result in unpredictable behavior.

For a complete description of all the registers in the PCB, see the *Am186ED/EDLV Microcontrollers User's Manual*, order# 21335A.

Table 8. Peripheral Control Block Register Map

Register Name	Offset
<b>Processor Control Registers:</b>	
Peripheral control block relocation register	FEh
Reset configuration register	F6h
Processor release level register <sup>1</sup>	F4h
Auxiliary configuration register <sup>1</sup>	F2h
System configuration register <sup>1</sup>	F0h
Watchdog timer control register	E6h
Enable RCU register <sup>1</sup>	E4h
Clock prescaler register <sup>1</sup>	E2h
(See note 2.)	
<b>DMA Registers:</b>	
DMA 1 control register	DAh
DMA 1 transfer count register	D8h
DMA 1 destination address high register	D6h
DMA 1 destination address low register	D4h
DMA 1 source address high register	D2h
DMA 1 source address low register	D0h
DMA 0 control register	CAh
DMA 0 transfer count register	C8h
DMA 0 destination address high register	C6h
DMA 0 destination address low register	C4h
DMA 0 source address high register	C2h
DMA 0 source address low register	C0h
<b>Chip-Select Registers:</b>	
$\overline{PCS}$ and $\overline{MCS}$ auxiliary register	A8h
Midrange memory chip-select register	A6h
Peripheral chip-select register	A4h
Low memory chip-select register <sup>1</sup>	A2h
Upper memory chip-select register <sup>1</sup>	A0h
<b>Serial Port 0 Registers:</b>	
Serial port 0 baud rate divisor register	88h
Serial port 0 receive register	86h
Serial port 0 transmit register	84h
Serial port 0 status register	82h
Serial port 0 control register	80h
<b>PIO Registers:</b>	
PIO data 1 register	7Ah
PIO direction 1 register	78h
PIO mode 1 register	76h
PIO data 0 register	74h
PIO direction 0 register	72h
PIO mode 0 register	70h
<b>Timer Registers:</b>	
Timer 2 mode/control register	66h

Register Name	Offset
Timer 2 max count compare A register	62h
Timer 2 count register	60h
Timer 1 mode/control register	5Eh
Timer 1 max count compare B register	5Ch
Timer 1 max count compare A register	5Ah
Timer 1 count register	58h
Timer 0 mode/control register	56h
Timer 0 max count compare B register	54h
Timer 0 max count compare A register	52h
Timer 0 count register	50h
<b>Interrupt Registers:</b>	
Serial port 0 interrupt control register	44h
Serial port 1 interrupt control register	42h
INT4 interrupt control register	40h
INT3 control register	3Eh
INT2 control register	3Ch
INT1 control register	3Ah
INT0 control register	38h
DMA1/INT6 interrupt control register	36h
DMA0/INT5 interrupt control register	34h
Timer interrupt control register	32h
Interrupt status register	30h
Interrupt request register	2Eh
Interrupt in-service register	2Ch
Interrupt priority mask register	2Ah
Interrupt mask register	28h
Interrupt poll status register	26h
Interrupt poll register	24h
End-of-interrupt register	22h
Interrupt vector register	20h
<b>Serial Port 1 Registers:</b>	
Serial port 1 baud rate divisor register	18h
Serial port 1 receive register	16h
Serial port 1 transmit register	14h
Serial port 1 status register	12h
Serial port 1 control register	10h

All unused addresses are reserved and should not be accessed.

**Notes:**

1. The register has been modified from the Am186ES/Am188ES microcontrollers.
2. The previous Memory Partition Register (MDRAM) has been removed and its functionality replaced with the  $\overline{CAS}$ -before- $\overline{RAS}$  refresh mode.

**CLOCK AND POWER MANAGEMENT**

The clock and power management unit of the Am186ED/EDLV microcontrollers includes a phase-locked loop (PLL) and a second programmable system clock output (CLKOUTB).

**Phase-Locked Loop**

In a traditional 80C186/188 microcontroller design, the crystal frequency is twice that of the desired internal clock. Because of the PLL on the Am186ED/EDLV microcontrollers, the internal clock generated by the Am186ED/EDLV microcontrollers (CLKOUTA) is the same frequency as the crystal. The PLL takes the crystal inputs (X1 and X2) and generates a 45–55% (worst case) duty cycle intermediate system clock of the same frequency. This removes the need for an external 2x oscillator, reducing system cost. The PLL is reset during power-on reset by an on-chip power-on reset (POR) circuit.

**Crystal-Driven Clock Source**

The internal oscillator circuit of the Am186ED/EDLV microcontrollers is designed to function with a parallel resonant fundamental or third overtone crystal. Because of the PLL, the crystal frequency should be equal to the processor frequency. Do not replace a crystal with an LC or RC equivalent.

The X1 and X2 signals are connected to an internal inverting amplifier (oscillator) that provides, along with the external feedback loading, the necessary phase shift (Figure 8). In such a positive feedback circuit, the inverting amplifier has an output signal (X2) 180 degrees out of phase of the input signal (X1).

The external feedback network provides an additional 180-degree phase shift. In an ideal system, the input to X1 will have 360 or zero degrees of phase shift. The external feedback network is designed to be as close to ideal as possible. If the feedback network is not providing necessary phase shift, negative feedback dampens

the output of the amplifier and negatively affects the operation of the clock generator. Values for the loading on X1 and X2 must be chosen to provide the necessary phase shift and crystal operation.

**Selecting a Crystal**

When selecting a crystal, the load capacitance should always be specified ( $C_L$ ). This value can cause variance in the oscillation frequency from the desired specified value (resonance). The load capacitance and the loading of the feedback network have the following relationship:

$$C_L = \frac{(C_1 \cdot C_2)}{(C_1 + C_2)} + C_S$$

where  $C_S$  is the stray capacitance of the circuit. Placing the crystal and  $C_L$  in series across the inverting amplifier and tuning these values ( $C_1, C_2$ ) allows the crystal to oscillate at resonance. This relationship is true for both fundamental and third-overtone operation. Finally, there is a relationship between  $C_1$  and  $C_2$ . To enhance the oscillation of the inverting amplifier, these values need to be offset with the larger load on the output (X2). Equal values of these loads tend to balance the poles of the inverting amplifier.

The characteristics of the inverting amplifier set limits on the following parameters for crystals:

- ESR (Equivalent Series Resistance) ..... 60  $\Omega$  max
- Drive Level ..... 1 mW max

The recommended range of values for  $C_1$  and  $C_2$  are as follows:

- $C_1$  ..... 15 pF  $\pm$  20%
- $C_2$  ..... 22 pF  $\pm$  20%

The specific values for  $C_1$  and  $C_2$  must be determined by the designer and are dependent on the characteristics of the chosen crystal and board design.

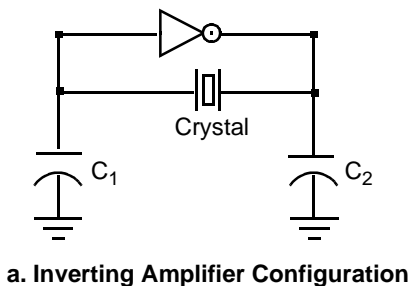

a. Inverting Amplifier Configuration

**Note 1: Use for Third Overtone Mode**

XTAL Frequency	L1 Value (Max)
20 MHz	12 $\mu$ H $\pm$ 20%
25 MHz	8.2 $\mu$ H $\pm$ 20%
33 MHz	4.7 $\mu$ H $\pm$ 20%
40 MHz	3.0 $\mu$ H $\pm$ 20%

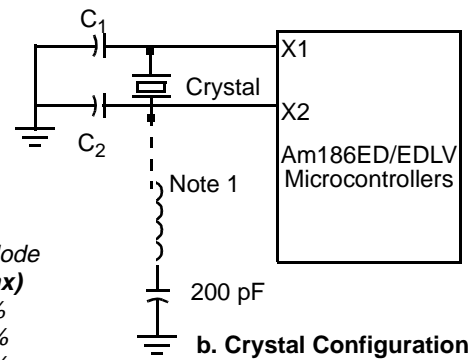

b. Crystal Configuration

**Figure 8. Am186ED/EDLV Microcontrollers Oscillator Configurations**

## External Source Clock

Alternately, the internal oscillator can be driven from an external clock source. This source should be connected to the input of the inverting amplifier (X1), with the output (X2) not connected.

## System Clocks

The base system clock of AMD's original 80C186 and 80C188 microcontrollers is renamed CLKOUTA and the additional output is called CLKOUTB. CLKOUTA and CLKOUTB operate at either the processor frequency or the PLL frequency. The output drivers for both clocks are individually programmable for disable. Figure 9 shows the organization of the clocks.

The second clock output (CLKOUTB) allows one clock to run at the PLL frequency and the other clock to run at the power-save frequency. Individual drive enable bits allow selective enabling of just one or both of these clock outputs.

## Power-Save Operation

The power-save mode of the Am186ED/EDLV microcontrollers reduces power consumption and heat dissipation, thereby extending battery life in portable systems. In power-save mode, operation of the CPU and internal peripherals continues at a slower clock frequency. When an interrupt occurs, the microcontroller automatically returns to its normal operating frequency on the internal clock's next rising edge of  $t_3$ .

**Note:** Power-save operation requires that clock-dependent devices be reprogrammed for clock frequency changes. Software drivers must be aware of clock frequency. The power-save divisor should not be set to operate the processor core below 100 kHz.

## Initialization and Processor Reset

Processor initialization or startup is accomplished by driving the  $\overline{RES}$  input pin Low.  $\overline{RES}$  must be held Low for 1 ms during power-up to ensure proper device initialization.  $\overline{RES}$  forces the Am186ED/EDLV microcontrollers to terminate all execution and local bus activity. No instruction or bus activity occurs as long as  $\overline{RES}$  is active. After  $\overline{RES}$  becomes inactive and an internal processing interval elapses, the microcontroller begins execution with the instruction at physical location FFFF0h, with  $\overline{UCS}$  asserted with three wait states.  $\overline{RES}$  also sets some registers to predefined values and resets the watchdog timer.

## Reset Configuration Register

When the  $\overline{RES}$  input is asserted Low, the contents of the address/data bus (AD15–AD0) are written into the reset configuration register. The system can place configuration information on the address/data bus using weak external pullup or pulldown resistors, or using an external driver that is enabled during reset. The processor does not drive the address/data bus during reset.

For example, the reset configuration register could be used to provide the software with the position of a configuration switch in the system. Using weak external pullup and pulldown resistors on the address and data bus, the system can provide the microcontroller with a value corresponding to the position of the jumper during a reset.

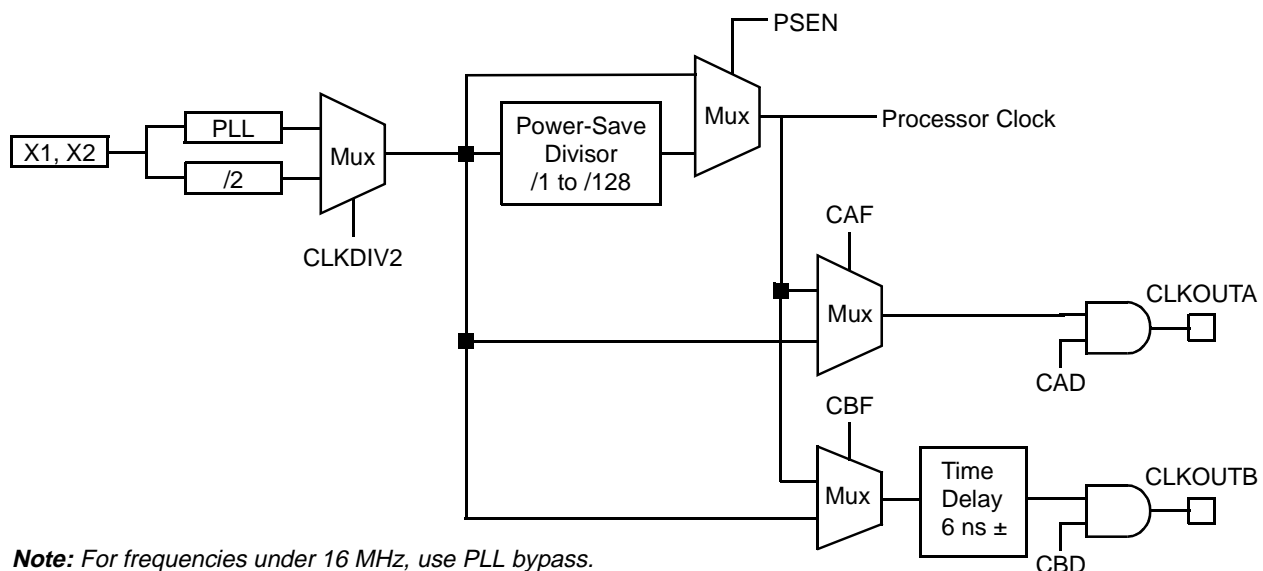

**Note:** For frequencies under 16 MHz, use PLL bypass.

Figure 9. Clock Organization



## CHIP-SELECT UNIT

The Am186ED/EDLV microcontrollers contain logic that provides programmable chip-select generation for both memories and peripherals. The logic can be programmed to provide ready and wait-state generation and latched address bits A1 and A2. The chip-select lines are active for all memory and I/O cycles in their programmed areas, whether they are generated by the CPU or by the integrated DMA unit.

The Am186ED/EDLV microcontrollers provide six chip-select outputs for use with memory devices and six more for use with peripherals in either memory space or I/O space. The six memory chip selects can be used to address three memory ranges. Each peripheral chip select addresses a 256-byte block that is offset from a programmable base address. A write to a chip select register will enable the corresponding chip select logic even if the actual pin has another function (e.g., PIO).

### Chip-Select Timing

The timing for the  $\overline{UCS}$  and  $\overline{LCS}$  outputs is modified from the original 80C186 microcontroller. These outputs now assert in conjunction with the nonmultiplexed address bus for normal memory timing. To allow these outputs to be available earlier in the bus cycle, the number of programmable memory size selections has been reduced.

### Ready and Wait-State Programming

The Am186ED/EDLV microcontrollers can be programmed to sense a ready signal for each of the peripheral or memory chip-select lines. The ready signal can be either the ARDY or SRDY signal. Each chip-select control register (UMCS, LMCS, MMCS, PACS, and MPCS) contains a single-bit field that determines whether the external ready signal is required or ignored.

The number of wait states to be inserted for each access to a peripheral or memory region is programmable. The chip-select control registers for  $\overline{UCS}$ ,  $\overline{LCS}$ ,  $\overline{MCS3}$ – $\overline{MCS0}$ ,  $\overline{PCS6}$ , and  $\overline{PCS5}$  contain a two-bit field that determines the number of wait states from zero to three to be inserted.  $\overline{PCS3}$ – $\overline{PCS0}$  use three bits to provide additional values of 5, 7, 9, and 15 wait states.

When external ready is required, internally programmed wait states will always complete before external ready can terminate or extend a bus cycle. For example, if the internal wait states are set to insert two wait states, the processor samples the external ready pin during the first wait cycle. If external ready is asserted at that time, the access completes after six cycles (four cycles plus two wait states). If external ready is not asserted during the first wait cycle, the access is extended until ready is asserted, and one more wait state occurs followed by  $t_4$ .

The ARDY signal on the Am186ED/EDLV microcontrollers is a true asynchronous ready signal. The ARDY pin accepts a rising edge that is asynchronous to CLKOUTA and is active High. If the falling edge of ARDY is not synchronized to CLKOUTA as specified, an additional clock period may be added.

### Chip-Select Overlap

Although programming the various chip selects on the Am186ED/EDLV microcontrollers so that multiple chip select signals are asserted for the same physical address is not recommended, it may be unavoidable in some systems. In such systems, the chip selects whose assertions overlap must have the same configuration for ready (external ready required or not required) and the number of wait states to be inserted into the cycle by the processor. The one exception to this is  $\overline{PCS}$  overlapping DRAM.

The peripheral control block (PCB) is accessed using internal signals. These internal signals function as chip selects configured with zero wait states and no external ready. Therefore, the PCB can be programmed to addresses that overlap external chip-select signals only if those external chip selects are programmed to zero wait states with no external ready required.

When overlapping an additional chip select with either the  $\overline{LCS}$  or  $\overline{UCS}$  chip selects, it must be noted that setting the Disable Address (DA) bit in the LMCS or UMCS register disables the address from being driven on the AD bus for all accesses for which the associated chip select is asserted, including any accesses for which multiple chip selects assert.

The  $\overline{MCS}$  and  $\overline{PCS}$  chip-select pins can be configured as either chip selects (normal function) or as PIO inputs or outputs. It should be noted, however, that the ready and wait state generation logic for these chip selects is in effect regardless of their configurations as chip selects or PIOs. This means that if these chip selects are enabled (by a write to the MMCS and MPCS for the  $\overline{MCS}$  chip selects, or by a write to the PACS and MPCS registers for the  $\overline{PCS}$  chip selects), the ready and wait state programming for these signals must agree with the programming for any other chip selects with which their assertion would overlap if they were configured as chip selects.

Although the  $\overline{PCS4}$  signal is not available on an external pin, the ready and wait state logic for this signal still exists internal to the part. For this reason, the  $\overline{PCS4}$  address space must follow the rules for overlapping chip selects. The ready and wait-state logic for  $\overline{PCS6}$ – $\overline{PCS5}$  is disabled when these signals are configured as address bits A2–A1.

Failure to configure overlapping chip selects with the same ready and wait state requirements may cause



the processor to hang with the appearance of waiting for a ready signal. This behavior may occur even in a system in which ready is always asserted (ARDY or SRDY tied High).

Configuring PCS in I/O space with LCS or any other chip select configured for memory address 0 is not considered overlapping of the chip selects. Overlapping chip selects refers to configurations where more than one chip select asserts for the same physical address.

The PCS can overlap DRAM blocks with different wait states and without external or internal bus contention. The RAS will assert along with the appropriate PCS. The UCAS and LCAS will not assert, preventing the DRAM from writing erroneously or driving the data bus during a read. The PCS must have the same or higher number of wait states than the DRAM. The PCS bus width will be determined by the LSIZ or USIZ bus widths. This will make a 1785-byte block of the DRAM inaccessible. In its place, the peripherals associated with the PCS can be accessed. This is especially useful when the entire memory space is used with two banks of DRAM or a bank of DRAM and a 512K Flash.

### Upper Memory Chip Select

The Am186ED/EDLV microcontrollers provide a UCS chip select for the top of memory. On reset the Am186ED/EDLV microcontrollers begin fetching and executing instructions at memory location FFFF0h. Therefore, upper memory is usually used as instruction memory. To facilitate this usage, UCS defaults to active on reset, with a default memory range of 64 Kbytes from F0000h to FFFFFh, with external ready required and three wait states automatically inserted. The UCS memory range always ends at FFFFFh. The UCS lower boundary is programmable.

The bus width associated with UCS is determined on reset by the S2/BTSEL. If S2/BTSEL is pulled High or left floating, an internal pullup sets the boot mode option to 16-bit. If S2/BTSEL is pulled resistively Low during reset, the boot mode option is for 8-bit. The status of the S2/BTSEL pin is latched on the rising edge of reset. If 8-bit mode is selected, the width of the memory region associated with UCS can be changed in the AUXCON register. If UCS boots as a 16-bit space, it is not re-configurable to 8-bit. This allows for cheaper 8-bit-wide memory to be used for booting the Am186ED/EDLV microcontrollers, while speed-critical code and data can be executed from 16-bit-wide lower memory. Eight-bit or 16-bit-wide peripherals can be used in the memory area between LCS and UCS or in the I/O space. The entire memory map can be set to 16-bit or 8-bit or mixed between 8-bit and 16-bit based on the USIZ, LSIZ, MSIZ, and IOSIZ bits in the AUXCON register.

### Low Memory Chip Select

The Am186ED/EDLV microcontrollers provide an LCS chip select for lower memory. The AUXCON register can be used to configure LCS for 8-bit or 16-bit accesses. Since the interrupt vector table is located at the bottom of memory starting at 00000h, the LCS pin is usually used to control data memory. The LCS pin is not active on reset.

The LCS signal is multiplexed with the RAS0 signal when the DRAM mode is enabled in the LMCS register.

### Midrange Memory Chip Selects

The Am186ED/EDLV microcontrollers provide four chip selects, MCS3–MCS0, for use in a user-locatable memory block. With some exceptions, the base address of the memory block can be located anywhere within the 1-Mbyte memory address space. The areas associated with the UCS and LCS chip selects are excluded. If they are mapped to memory, the address range of the peripheral chip selects, PCS6, PCS5, and PCS3–PCS0, are also excluded. The MCS address range can overlap the PCS address range if the PCS chip selects are mapped to I/O space.

MCS0 can be configured to be asserted for the entire MCS range. When configured in this mode, the MCS3–MCS1 pins can be used as PIOs or DRAM control signals.

The AUXCON register can be used to configure MCS for 8-bit or 16-bit accesses. The bus width of the MCS range is determined by the width of the non-UCS/non-LCS memory range.

Unlike the UCS and LCS chip selects, the MCS outputs assert with the same timing as the multiplexed AD address bus.

Activating either bank of DRAM will change the MCS1 and MCS2 functionality to UCAS and LCAS. Activating the upper DRAM bank will change the MCS3 functionality to RAS1. It is recommended that when either bank of DRAM is activated, either MCS0 be configured to assert for the entire MCS range or that MCS space be unused. If the lower bank of DRAM is activated, but not the upper bank of DRAM, MCS3 can still be used as a chip select or PIO. The MCS2 and MCS1 portion of the middle chip select address space will not have a chip select signal asserted, but the wait states will still be valid.

### Peripheral Chip Selects

The Am186ED/EDLV microcontrollers provide six chip selects, PCS6–PCS5 and PCS3–PCS0, for use within a user-configured memory or I/O block. PCS4 is not available on the Am186ED/EDLV microcontrollers. The base address of the memory block can be located anywhere within the 1-Mbyte memory address space, exclusive of the areas associated with the UCS, LCS, and

$\overline{MCS}$  chip selects, or they can be configured to access the 64-Kbyte I/O space.

The  $\overline{PCS}$  pins are not active on reset.  $\overline{PCS6}$ – $\overline{PCS5}$  can be programmed for zero to three wait states.  $\overline{PCS3}$ – $\overline{PCS0}$  can be programmed for four additional wait-state values: 5, 7, 9, and 15.

The AUXCON register can be used to configure  $\overline{PCS}$  for 8-bit or 16-bit accesses. The bus width of the  $\overline{PCS}$  range is determined by the width of the non- $\overline{UCS}$ /non- $\overline{LCS}$  memory range or by the width of the I/O area.

Unlike the  $\overline{UCS}$  and  $\overline{LCS}$  chip selects, the  $\overline{PCS}$  outputs assert with the multiplexed AD address bus. Each peripheral chip select asserts over a 256-byte address range, which is twice the address range covered by peripheral chip selects in the 80C186/188 microcontrollers.

The  $\overline{PCS}$  allows for overlap in memory space with the DRAM ( $\overline{RAS0}$ ,  $\overline{RAS1}$ ) space. Overlap of the  $\overline{PCS}$  with  $\overline{LCS}$ ,  $\overline{MCS}$ , or  $\overline{UCS}$  in a non-DRAM mode is not recommended. If overlap of the  $\overline{PCS}$  with  $\overline{MCS}$ ,  $\overline{LCS}$ , or  $\overline{UCS}$  occurs, the same number of wait states and external ready must be used. If overlap of  $\overline{PCS}$  with DRAM space occurs, the DRAM controller will assert  $\overline{RAS}$  and stop the  $\overline{CAS}$  signal from asserting. This will not modify the contents of the DRAM and the access will continue as a normal  $\overline{PCS}$  access. When overlapping the  $\overline{PCS}$  with DRAM, the number of wait states can be different for  $\overline{PCS}$  space.  $\overline{PCS}$  wait states must be greater than or equal to DRAM wait states. The ready and wait states will be determined by the  $\overline{PCS}$  programming in the MPCS and PACS registers.

$\overline{PCS}$  space should not contain the address FFFFh, which is the address used for a refresh cycle. The AD15–AD0 bus will drive FFFFh during a refresh cycle for the address portion of cycle.

## REFRESH CONTROL UNIT

The refresh control unit (RCU) automatically generates refresh bus cycles when enabled. After a programmable period of time, the RCU generates a  $\overline{CAS}$ -before- $\overline{RAS}$  refresh bus cycle. The RCU should not be enabled if at least one bank of DRAM is not enabled. All refreshes will be 7 clocks, no matter how the DRAM wait states are programmed. During a refresh cycle, the A19–A0 bus is undefined; the AD15–AD0 bus is driven with all 1s (FFFFh). The  $\overline{PCS}$  and  $\overline{MCS}$  chip selects are decoded by the processor using a 20-bit version of the AD bus. The highest four bits of this internal bus are not available externally; however, internally these bits are set to all 1s during a refresh cycle, resulting in the 20-bit address FFFFh. For this reason, the  $\overline{MCS}$  and  $\overline{PCS}$  chip selects should not contain the address FFFFh while DRAM is enabled.

## INTERRUPT CONTROL UNIT

The Am186ED/EDLV microcontrollers can receive interrupt requests from a variety of sources, both internal and external. The internal interrupt controller arranges these requests by priority and presents them one at a time to the CPU.

There are up to eight external interrupt sources on the Am186ED/EDLV microcontrollers—seven maskable interrupt pins and one nonmaskable interrupt (NMI) pin. In addition, there are eight internal interrupt sources (three timers, two DMA channels, two asynchronous serial ports, and the Watchdog Timer NMI) that are not connected to external pins. INT5 and INT6 are multiplexed with DRQ0 and DRQ1. These two interrupts are available if the associated DMA is not enabled or is being used with internal synchronization.

The Am186ED/EDLV microcontrollers provide up to six interrupt sources not present on the 80C186 and 80C188 microcontrollers. There are up to three additional external interrupt pins—INT4, INT5, and INT6. These pins operate much like the INT3–INT0 interrupt pins on the 80C186 and 80C188 microcontrollers. There are also two internal interrupts from the serial ports and the watchdog timer can generate interrupts.

INT5 and INT6 are multiplexed with the DMA request signals, DRQ0 and DRQ1. If a DMA channel is not enabled, or if it is not using external synchronization, then the associated pin can be used as an external interrupt. INT5 and INT6 can also be used in conjunction with the DMA terminal count interrupts.

The seven maskable interrupt request pins can be used as direct interrupt requests. INT4–INT0 can be either edge-triggered or level-triggered. INT6 and INT5 are edge-triggered only. In addition, INT0 and INT1 can be configured in cascade mode for use with an external 82C59A-compatible interrupt controller. When INT0 is configured in cascade mode, the INT2 pin is automatically configured in its  $\overline{INTA0}$  function. When INT1 is configured in cascade mode, the INT3 pin is automatically configured in its  $\overline{INTA1}$  function. An external interrupt controller can be used as the system master by programming the internal interrupt controller to operate in slave mode. INT6–INT4 are not available in slave mode.

Interrupts are automatically disabled when an interrupt is taken. Interrupt-service routines (ISRs) may re-enable interrupts by setting the IF flag. This allows interrupts of greater or equal priority to interrupt the currently executing ISR. Interrupts from the same source are disabled as long as the corresponding bit in the interrupt in-service register is set. INT1 and INT0 provide a special bit to enable special fully nested mode. When configured in special fully nested mode, the interrupt source may generate a new interrupt regardless of the setting of the in-service bit.

## TIMER CONTROL UNIT

There are three 16-bit programmable timers and a watchdog timer on the Am186ED/EDLV microcontrollers.

Timer 0 and timer 1 are connected to four external pins (each one has an input and an output). These two timers can be used to count or time external events, or to generate nonrepetitive or variable-duty-cycle waveforms. When pulse width demodulation is enabled, timer 0 and timer 1 are used to measure the width of the High and Low pulses on the PWD pin. (See the Pulse Width Demodulation section on page 45.)

Timer 2 is not connected to any external pins. It can be used for real-time coding and time-delay applications. It can also be used as a prescaler to timers 0 and 1 or to synchronize DMA transfers.

The programmable timers are controlled by eleven 16-bit registers in the peripheral control block. A timer's timer-count register contains the current value of that timer. The timer-count register can be read or written with a value at any time, whether the timer is running or not. The microcontroller increments the value of the timer-count register each time a timer event occurs.

Each timer also has a maximum-count register that defines the maximum value the timer can reach. When the timer reaches the maximum value, it resets to 0 during the same clock cycle. The value in the maximum-count register is never stored in the timer-count register. Also, timers 0 and 1 have a secondary maximum-count register. Using both the primary and secondary maximum-count registers lets the timer alternate between two maximum values.

If the timer is programmed to use only the primary maximum-count register, the timer output pin switches Low for one clock cycle after the maximum value is reached. If the timer is programmed to use both of its maximum-count registers, the output pin indicates which maximum-count register is currently in control, thereby creating a waveform. The duty cycle of the waveform depends on the values in the maximum-count registers.

Each timer is serviced every fourth clock cycle, so a timer can operate at a speed of up to one-quarter of the internal clock frequency. A timer can be clocked externally at this same frequency; however, because of internal synchronization and pipelining of the timer circuitry, the timer output can take up to six clock cycles to respond to the clock or gate input.

### Watchdog Timer

The Am186ED/EDLV microcontrollers provide a true watchdog timer function. The Watchdog Timer (WDT) can be used to regain control of the system when software fails to respond as expected. The WDT is active

after reset. It can only be modified a single time by a keyed sequence of writes to the watchdog timer control register (WDTCON) following reset. This single write can either disable the timer or modify the timeout period and the action taken upon timeout. A keyed sequence is also required to reset the current WDT count. This behavior ensures that randomly executing code will not prevent a WDT event from occurring.

The WDT supports up to a 1.67-second timeout period in a 40-MHz system. After reset, the WDT is enabled and the timeout period is set to its maximum value.

The WDT can be configured to cause either an NMI interrupt or a system reset upon timeout. If the WDT is configured for NMI, the NMIFLAG in the WDTCON register is set when the NMI is generated. The NMI interrupt service routine (ISR) should examine this flag to determine if the interrupt was generated by the WDT or by an external source. If the NMIFLAG is set, the ISR should clear the flag by writing the correct keyed sequence to the WDTCON register. If the NMIFLAG is set when a second WDT timeout occurs, a WDT system reset is generated rather than a second NMI event.

When the processor takes a WDT reset, either due to a single WDT event with the WDT configured to generate resets or due to a WDT event with the NMIFLAG set, the RSTFLAG in the WDTCON register is set. This allows system initialization code to differentiate between a hardware reset and a WDT reset and take appropriate action. The RSTFLAG is cleared when the WDTCON register is read or written. The processor does not resample external pins during a WDT reset. This means that the clocking, the reset configuration register, and any other features that are user-selectable during reset do not change when a WDT system reset occurs. All other activities are identical to those of a normal system reset.

**Note:** *The Watchdog Timer (WDT) is active after reset.*

## PULSE WIDTH DEMODULATION

For many applications, such as bar-code reading, it is necessary to measure the width of a signal in both its High and Low phases. The Am186ED/EDLV microcontrollers provide a pulse-width demodulation (PWD) option to fulfill this need. The PWD bit in the System Configuration Register (SYSCON) enables the PWD option. Analog-to-digital conversion is not supported.

In PWD mode, TMRIN0, TMRIN1, INT2, and INT4 are configured internal to the microcontroller to support the detection of rising and falling edges on the PWD input pin (INT2/INTA0/PWD) and to enable either timer 0 when the signal is High or timer 1 when the signal is Low. The INT4, TMRIN0, and TMRIN1 pins are not used in PWD mode and so are available for use as PIOs.

The following diagram shows the behavior of a system for a typical waveform.

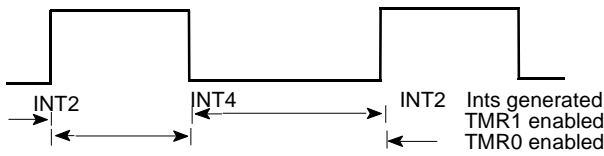

The interrupt service routine (ISR) for the INT2 and INT4 interrupts should examine the current count of the associated timer, timer 1 for INT2, and timer 0 for INT4, in order to determine the pulse width. The ISR should then reset the timer count register in preparation for the next pulse.

Since the timers count at one quarter of the processor clock rate, this determines the maximum resolution that can be obtained. Further, in applications where the pulse width may be short, it may be necessary to poll the INT2 and INT4 request bits in the interrupt request register in order to avoid the overhead involved in taking and returning from an interrupt. Overflow conditions, where the pulse width is greater than the maximum count of the timer, can be detected by monitoring the Maximum Count (MC) bit in the associated timer or by setting the INT bit to enable timer interrupt requests.

**DIRECT MEMORY ACCESS**

Direct memory access (DMA) permits transfer of data between memory and peripherals without CPU involvement. The DMA unit shown in Figure 10, provides two high-speed DMA channels. Data transfers can occur between memory and I/O spaces (e.g., memory to I/O) or within the same space (e.g., memory to memory or I/O to I/O). Table 9 shows maximum DMA transfer rates.

The DMA channels can be directly connected to the asynchronous serial ports. DMA and serial port transfer is accomplished by programming the DMA controller to perform transfers between a data source in memory or I/O space and a serial port transmit or receive register. The two DMA channels can support one serial port in full-duplex mode or two serial ports in half-duplex mode.

Either bytes or words can be transferred to or from even or odd addresses. However, word DMA transfers to or from memory configured for 8-bit accesses are not supported. Only two bus cycles (a minimum of eight clocks) are necessary for each data transfer.

Each channel accepts a DMA request from one of four sources: the channel request pin (DRQ1–DRQ0), Timer 2, a serial port, or the system software. The channels can be programmed with different priorities in

the event of a simultaneous DMA request or if there is a need to interrupt transfers on the other channel.

**DMA Operation**

Each channel has six registers in the peripheral control block that define specific channel operations. The DMA registers consist of a 20-bit source address (two registers), a 20-bit destination address (two registers), a 16-bit transfer count register, and a 16-bit control register.

The DMA Transfer Count Register (DTC) specifies the number of DMA transfers to be performed. Up to 64K of byte or word transfers can be performed with automatic termination. The DMA control registers define the channel operation. All registers can be modified during any DMA activity. Any changes made to the DMA registers are reflected immediately in DMA operation.

**Table 9. Am186ED/EDLV Microcontrollers  
Maximum DMA Transfer Rates**

Type of Synchronization Selected	Maximum DMA Transfer Rate (Mbytes)			
	40 MHz	33 MHz	25 MHz	20 MHz
Unsynchronized	10	8.25	6.25	5
Source Synchronized	10	8.25	6.25	5
Destination Synchronized (CPU needs bus)	6.6	5.5	4.16	3.3
Destination Synch (CPU does not need bus)	8	6.6	5	4



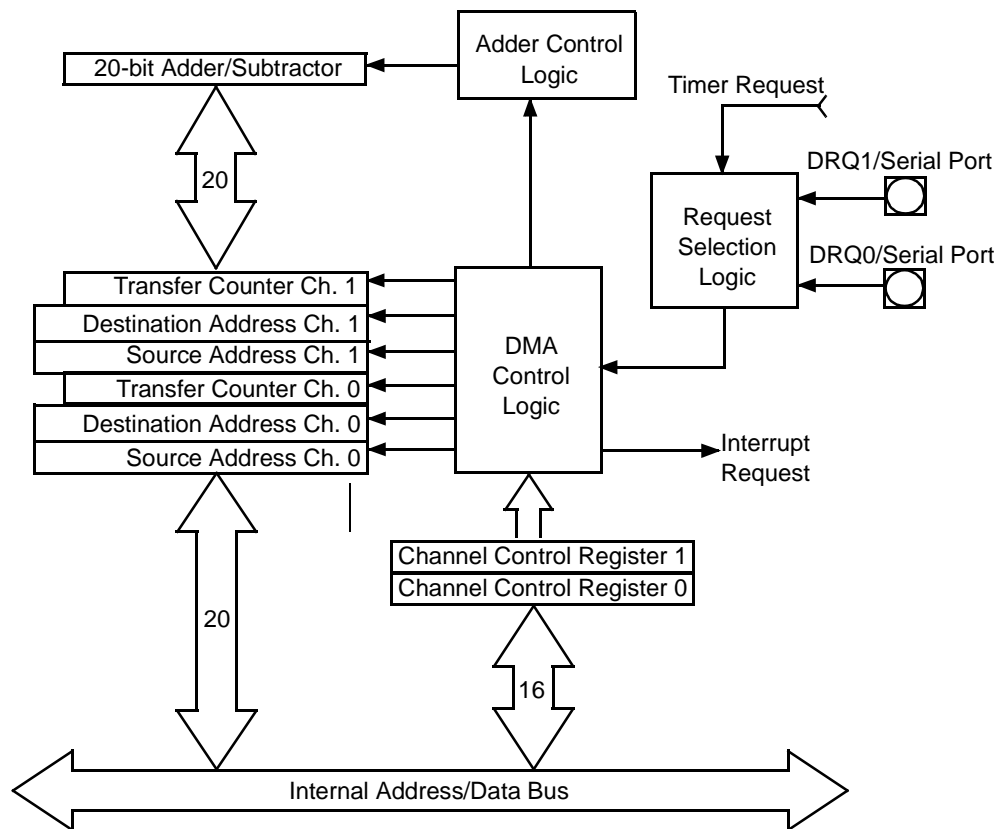

Figure 10. DMA Unit Block Diagram

## DMA Channel Control Registers

Each DMA control register determines the mode of operation for the particular DMA channel. The DMA control registers specify the following:

- The mode of synchronization
- Whether bytes or words are transferred
- Whether an interrupt is generated after the last transfer
- Whether the DRQ pins are configured as INT pins
- Whether DMA activity ceases after a programmed number of DMA cycles
- The relative priority of the DMA channel with respect to the other DMA channel
- Whether the source address is incremented, decremented, or maintained constant after each transfer
- Whether the source address addresses memory or I/O space
- Whether the destination address is incremented, decremented, or maintained constant after transfers
- Whether the destination address addresses memory or I/O space

## DMA Priority

The DMA channels can be programmed so that one channel is always given priority over the other, or they can be programmed to alternate cycles when both have DMA requests pending. DMA cycles always have priority over internal CPU cycles except between locked memory accesses or word accesses to odd memory locations. However, an external bus hold takes priority over an internal DMA cycle.

Because an interrupt request cannot suspend a DMA operation and the CPU cannot access memory during a DMA cycle, interrupt latency time suffers during sequences of continuous DMA cycles. An NMI request, however, causes all internal DMA activity to halt. This allows the CPU to respond quickly to the NMI request.

## ASYNCHRONOUS SERIAL PORTS

The Am186ED/EDLV microcontrollers provide two independent asynchronous serial ports. These ports provide full-duplex, bidirectional data transfer using several industry-standard communications protocols. The serial ports can be used as sources or destinations of DMA transfers.

The asynchronous serial ports support the following features:

- Full-duplex operation
- Direct memory access (DMA) from the serial ports
- 7-bit, 8-bit, or 9-bit data transfers
- Odd, even, or no parity
- One stop bit
- Long or short break character recognition
- Error detection
  - Parity errors
  - Framing errors
  - Overrun errors
  - Break character recognition
- Hardware handshaking with the following selectable control signals:
  - Clear-to-send ( $\overline{\text{CTS}}$ )
  - Enable-receiver-request ( $\overline{\text{ENRX}}$ )
  - Ready-to-send ( $\text{RTS}$ )
  - Ready-to-receive ( $\overline{\text{RTR}}$ )
- DMA to and from the serial ports
- Separate maskable interrupts for each port
- Multidrop protocol (9-bit) support
- Independent baud rate generators
- Maximum baud rate of 1/16th of the CPU clock
- Double-buffered transmit and receive
- Programmable interrupt generation for transmit, receive, and/or error detection

### DMA Transfers through the Serial Port

The DMA channels can be directly connected to the asynchronous serial ports. DMA and serial port transfer is accomplished by programming the DMA controller to perform transfers between a memory or I/O space and a serial port transmit or receive register. The two DMA channels can support one serial port in full-duplex mode or two serial ports in half-duplex mode. See the DMA Control register descriptions in the *Am186ED/EDLV Microcontrollers User's Manual*, order# 21335A for more information.

### PROGRAMMABLE I/O (PIO) PINS

There are 32 pins on the Am186ED/EDLV microcontrollers that are available as user-programmable I/O signals. Table 2 on page 29 and Table 3 on page 29 list the PIO pins. Each of these pins can be used as a user-programmable input or output signal if the normal shared function is not needed.

If a pin is enabled to function as a PIO signal, the pre-assigned signal function is disabled and does not affect the level on the pin. A PIO signal can be configured to operate as an input or output with or without a weak pullup or pulldown, or as an open-drain output.

After power-on reset, the PIO pins default to various configurations. The column titled *Power-On Reset Status* in Table 2 on page 29 and Table 3 on page 29 lists the defaults for the PIOs. The system initialization code must reconfigure the PIOs as required.

The A19–A17 address pins default to normal operation on power-on reset, allowing the processor to correctly begin fetching instructions at the boot address FFFF0h. The  $\overline{\text{DT/R}}$ ,  $\overline{\text{DEN}}$ , and  $\overline{\text{SRDY}}$  pins also default to normal operation on power-on reset.

Note that emulators use A19, A18, A17, S6, and  $\overline{\text{UZI}}$ . In environments where an emulator is needed, these pins must be configured for normal function—not as PIOs.

If the AD15–AD0 bus override is enabled on power-on reset, then S6/ $\overline{\text{CLKDIV2}}$  and  $\overline{\text{UZI}}$  revert to normal operation instead of PIO input with pullup. If  $\overline{\text{BHE/ADEN}}$  is held Low during power-on reset, the AD15–AD0 bus override is enabled.

When the  $\overline{\text{PCS}}$  or  $\overline{\text{MCS}}$  are used as PIO inputs (only) and the bus is arbitrated, an internal pullup of ~10 kohms is activated, even if the pullup option for the PIO is not selected.



### ABSOLUTE MAXIMUM RATINGS

#### Storage temperature

Am186ED.....-65°C to +125°C  
 Am186EDLV.....-65°C to +125°C

#### Voltage on any pin with respect to ground

Am186ED.....-0.5 V to  $V_{CC} + 0.5$  V  
 Am186EDLV.....-0.5 V to  $V_{CC} + 0.5$  V

**Note:** Stresses above those listed under Absolute Maximum Ratings may cause permanent device failure. Functionality at or above these limits is not implied. Exposure to absolute maximum ratings for extended periods may affect device reliability.

### OPERATING RANGES

#### Am186ED Microcontroller

Commercial ( $T_C$ ) .....0°C to +100°C  
 Industrial\* ( $T_A$ ).....-40°C to +85°C  
 Supply voltage ( $V_{CC}$ ) .....5 V  $\pm$  10%

#### Am186EDLV Microcontroller

Commercial ( $T_A$ ) .....0°C to +70°C  
 $V_{CC}$  up to 25 MHz..... 3.3 V  $\pm$  0.3 V

Where:  $T_C$  = case temperature  
 $T_A$  = ambient temperature

\*Industrial versions of Am186ED microcontrollers are available in 20 and 25 MHz operating frequencies only.

### DC CHARACTERISTICS OVER COMMERCIAL AND INDUSTRIAL OPERATING RANGES

Symbol	Parameter Description	Test Conditions	Preliminary		Unit
			Min	Max	
$V_{IL}$	Input Low Voltage (Except X1)		-0.5	$0.2V_{CC} - 0.3$	V
$V_{IL1}$	Clock Input Low Voltage (X1)		-0.5	0.8	V
$V_{IH}$	Input High Voltage (Except $\overline{RES}$ and X1)		2.0	$V_{CC} + 0.5$	V
$V_{IH1}$	Input High Voltage ( $\overline{RES}$ )		2.4	$V_{CC} + 0.5$	V
$V_{IH2}$	Clock Input High Voltage (X1)		$V_{CC} - 0.8$	$V_{CC} + 0.5$	V
$V_{OL}$	<b>Output Low Voltage</b>				
	Am186ED	$I_{OL} = 2.5$ mA ( $\overline{S2} - \overline{S0}$ ) $I_{OL} = 2.0$ mA (others)		0.45	V
	Am186EDLV	$I_{OL} = 1.5$ mA ( $\overline{S2} - \overline{S0}$ ) $I_{OL} = 1.0$ mA (others)		0.45	V
$V_{OH}$	<b>Output High Voltage<sup>(a)</sup></b>				
	Am186ED	$I_{OH} = -2.4$ mA @ 2.4 V	2.4	$V_{CC} + 0.5$	V
		$I_{OH} = -200$ $\mu$ A @ $V_{CC} - 0.5$	$V_{CC} - 0.5$	$V_{CC}$	V
	Am186EDLV	$I_{OH} = -200$ $\mu$ A @ $V_{CC} - 0.5$	$V_{CC} - 0.5$	$V_{CC}$	V
$I_{CC}$	Power Supply Current @ 0°C	$V_{CC} = 5.5$ V <sup>(b)</sup> $V_{CC} = 3.6$ V <sup>(b)</sup>		5.9 4.0	mA/MHz
$I_{LI}$	Input Leakage Current @ 0.5 MHz	$0.45$ V $\leq V_{IN} \leq V_{CC}$		$\pm 10$	$\mu$ A
$I_{LO}$	Output Leakage Current @ 0.5 MHz	$0.45$ V $\leq V_{OUT} \leq V_{CC}$ <sup>(c)</sup>		$\pm 10$	$\mu$ A
$V_{CLO}$	Clock Output Low	$I_{CLO} = 4.0$ mA		0.45	V
$V_{CHO}$	Clock Output High	$I_{CHO} = -500$ $\mu$ A	$V_{CC} - 0.5$		V

**Notes:**

- a The  $\overline{LCS}/\overline{ONCE0}/\overline{RAS0}$  and  $\overline{UCS}/\overline{ONCE1}$  pins have weak internal pullup resistors. Loading the  $\overline{LCS}/\overline{ONCE0}/\overline{RAS0}$  and  $\overline{UCS}/\overline{ONCE1}$  pins in excess of  $I_{OH} = -200$   $\mu$ A during reset can cause the device to go into ONCE mode.
- b Current is measured with the device in RESET with X1 and X2 driven and all other non-power pins open but held High or Low.
- c Testing is performed with the pins floating, either during HOLD or by invoking the ONCE mode.

**CAPACITANCE**

Symbol	Parameter Description	Test Conditions	Preliminary		Unit
			Min	Max	
C <sub>IN</sub>	Input Capacitance	@ 1 MHz		10	pF
C <sub>IO</sub>	Output or I/O Capacitance	@ 1 MHz		20	pF

**Note:**  
Capacitance limits are guaranteed by characterization.

**POWER SUPPLY CURRENT**

For the following typical system specification shown in Figure 11, I<sub>CC</sub> has been measured at 4.0 mA per MHz of system clock. For the following typical system specification shown in Figure 12, I<sub>CC</sub> has been measured at 5.9 mA per MHz of system clock. The typical system is measured while the system is executing code in a typical application with nominal voltage and maximum case temperature. Actual power supply current is dependent on system design and may be greater or less than the typical I<sub>CC</sub> figure presented here.

Typical current in Figure 11 is given by:  
I<sub>CC</sub> = 4.0 mA · freq(MHz)

Typical current in Figure 12 is given by:  
I<sub>CC</sub> = 5.9 mA · freq(MHz)

Please note that dynamic I<sub>CC</sub> measurements are dependent upon chip activity, operating frequency, output buffer logic, and capacitive/resistive loading of the outputs. For these I<sub>CC</sub> measurements, the devices were set to the following modes:

- No DC loads on the output buffers
- Output capacitive load set to 35 pF
- AD bus set to data only
- PIOs are disabled
- Timer, serial port, refresh, and DMA are enabled

Table 10 shows the variables that are used to calculate the typical power consumption value for the Am186EDLV microcontroller.

**Table 10. Typical Power Consumption Calculation for the Am186EDLV Microcontroller**

MHz · I <sub>CC</sub> · Volts / 1000 = P			Typical Power in Watts
MHz	Typical I <sub>CC</sub>	Volts	
20	4.0	3.6	0.288
25	4.0	3.6	0.360

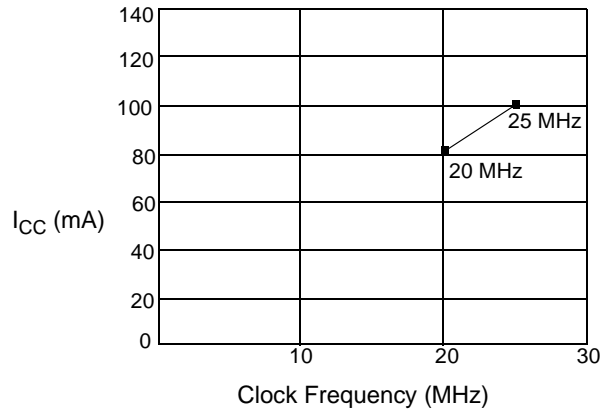

**Figure 11. Typical I<sub>CC</sub> Versus Frequency for Am186EDLV Microcontroller**

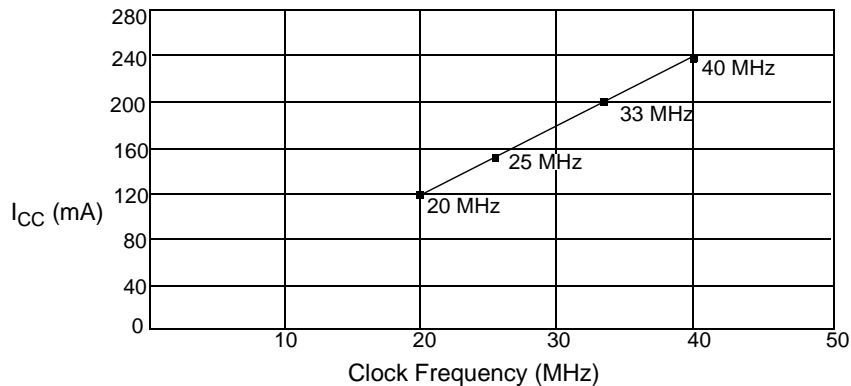

**Figure 12. Typical I<sub>CC</sub> Versus Frequency for Am186ED Microcontroller**

## THERMAL CHARACTERISTICS

### TQFP Package

The Am186ED microcontroller is specified for operation with case temperature ranges from 0°C to +100°C for a commercial device. Case temperature is measured at the top center of the package as shown in Figure 13. The various temperatures and thermal resistances can be determined using the equations in Figure 14 with information given in Table 11.

The total thermal resistance is  $\theta_{JA}$ ;  $\theta_{JA}$  is the sum of  $\theta_{JC}$ , the internal thermal resistance of the assembly, and  $\theta_{CA}$ , the case to ambient thermal resistance.

The variable  $P$  is power in watts. Power supply current ( $I_{CC}$ ) is in mA per MHz of clock frequency.

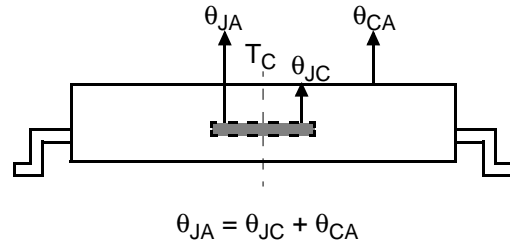

Figure 13. Thermal Resistance(°C/Watt)

$$\theta_{JA} = \theta_{JC} + \theta_{CA}$$

$$P = I_{CC} \cdot \text{freq (MHz)} \cdot V_{CC}$$

$$T_J = T_C + (P \cdot \theta_{JC})$$

$$T_J = T_A + (P \cdot \theta_{JA})$$

$$T_C = T_J - (P \cdot \theta_{JC})$$

$$T_C = T_A + (P \cdot \theta_{CA})$$

$$T_A = T_J - (P \cdot \theta_{JA})$$

$$T_A = T_C - (P \cdot \theta_{CA})$$

Figure 14. Thermal Characteristics Equations

Table 11. Thermal Characteristics (°C/Watt)

Package/Board	Airflow (Linear Feet per Minute)	$\theta_{JA}$	$\theta_{JC}$	$\theta_{CA}$
PQFP/2-Layer	0 fpm	45	7	38
	200 fpm	39	7	32
	400 fpm	35	7	28
	600 fpm	33	7	26
TQFP/2-Layer	0 fpm	56	10	46
	200 fpm	46	10	36
	400 fpm	40	10	30
	600 fpm	38	10	28
PQFP/4-Layer to 6-Layer	0 fpm	23	5	18
	200 fpm	21	5	16
	400 fpm	19	5	14
	600 fpm	17	5	12
TQFP/4-Layer to 6-Layer	0 fpm	30	6	24
	200 fpm	28	6	22
	400 fpm	26	6	20
	600 fpm	24	6	18

**Typical Ambient Temperatures**

The typical ambient temperature specifications are based on the following assumptions and calculations:

The commercial operating range of the Am186ED microcontroller is a case temperature  $T_C$  of 0 to 100 degrees Centigrade.  $T_C$  is measured at the top center of the package. An increase in the ambient temperature causes a proportional increase in  $T_C$ .

Microcontrollers up to 40 MHz are specified as 5.0 V plus or minus 10%. Therefore, 5.0 V is used for calculating typical power consumption up to 40 MHz.

Typical power supply current ( $I_{CC}$ ) in normal usage is estimated at 5.9 mA per MHz of microcontroller clock rate.

Typical power consumption (watts) = (5.9 mA/MHz) times microcontroller clock rate times  $V_{CC}$  divided by 1000.

Table 12 shows the variables that are used to calculate the typical power consumption value for each version of the Am186ED microcontroller.

**Table 12. Typical Power Consumption Calculation**

$P = \text{MHz} \cdot I_{CC} \cdot V_{CC}/1000$			Typical Power (P) in Watts
MHz	Typical $I_{CC}$	Volts	
40	5.9	5.0	1.2
33	5.9	5.0	1.0
25	5.9	5.0	0.7
20	5.9	5.0	0.6

Thermal resistance is a measure of the ability of a package to remove heat from a semiconductor device. A safe operating range for the device can be calculated using the formulas from Figure 14 and the variables in Table 11.

By using the maximum case rating  $T_C$ , the typical power consumption value from Table 12, and  $\theta_{JC}$  from Table 11, the junction temperature  $T_J$  can be calculated by using the following formula from Figure 14.

$$T_J = T_C + (P \cdot \theta_{JC})$$

Table 13 shows  $T_J$  values for the various versions of the Am186ED microcontroller. The column titled *Speed/Pkg/Board* in Table 13 indicates the clock speed in MHz, the type of package (P for PQFP and T for TQFP), and the type of board (2 for 2-layer and 4-6 for 4-layer to 6-layer).

**Table 13. Junction Temperature Calculation**

Speed/ Pkg/ Board	$T_J(^{\circ}\text{C})$	$T_J = T_C + (P \cdot \theta_{JC})$		
		$T_C$	P	$\theta_{JC}$
40/P2	108.3	100	1.2	7
40/T2	111.8	100	1.2	10
40/P4-6	105.9	100	1.2	5
40/T4-6	107.1	100	1.2	6
33/P2	106.8	100	1.0	7
33/T2	109.7	100	1.0	10
33/P4-6	104.9	100	1.0	5
33/T4-6	105.8	100	1.0	6
25/P2	105.2	100	0.7	7
25/T2	107.4	100	0.7	10
25/P4-6	103.7	100	0.7	5
25/T4-6	104.4	100	0.7	6
20/P2	104.1	100	0.6	7
20/T2	105.9	100	0.6	10
20/P4-6	103.0	100	0.6	5
20/T4-6	103.5	100	0.6	6

By using  $T_J$  from Table 13, the typical power consumption value from Table 12, and a  $\theta_{JA}$  value from Table 11, the typical ambient temperature  $T_A$  can be calculated using the following formula from Figure 14:

$$T_A = T_J - (P \cdot \theta_{JA})$$

For example,  $T_A$  for a 40-MHz PQFP design with a 2-layer board and 0 fpm airflow is calculated as follows:

$$T_A = 108.3 - (1.2 \cdot 45)$$

$$T_A = 55.2$$

In this calculation,  $T_J$  comes from Table 13, P comes from Table 12, and  $\theta_{JA}$  comes from Table 11. See Table 14.

$T_A$  for a 33-MHz TQFP design with a 4-layer to 6-layer board and 200 fpm airflow is calculated as follows:

$$T_A = 105.8 - (1.0 \cdot 28)$$

$$T_A = 78.6$$

See Table 17 for the result of this calculation.

Table 14 through Table 17 and Figure 15 through Figure 18 show  $T_A$  based on the preceding assumptions and calculations for a range of  $\theta_{JA}$  values with airflow from 0 linear feet per minute to 600 linear feet per minute.

Table 14 shows typical maximum ambient temperatures in degrees Centigrade for a PQFP package used on a 2-layer board. The typical ambient temperatures are based on a 100-degree Centigrade maximum case temperature. Figure 15 graphically illustrates the typical temperatures in Table 14.

**Table 14. Typical Ambient Temperatures (°C) for PQFP with a 2-Layer Board**

Microcontroller Speed	Typical Power (Watts)	Linear Feet per Minute Airflow			
		0 fpm	200 fpm	400 fpm	600 fpm
40 MHz	1.2	55.2	62.2	67.0	69.3
33 MHz	1.0	63.0	68.8	72.7	74.7
25 MHz	0.7	72.0	76.4	79.4	80.8
20 MHz	0.6	77.6	81.1	83.5	84.7

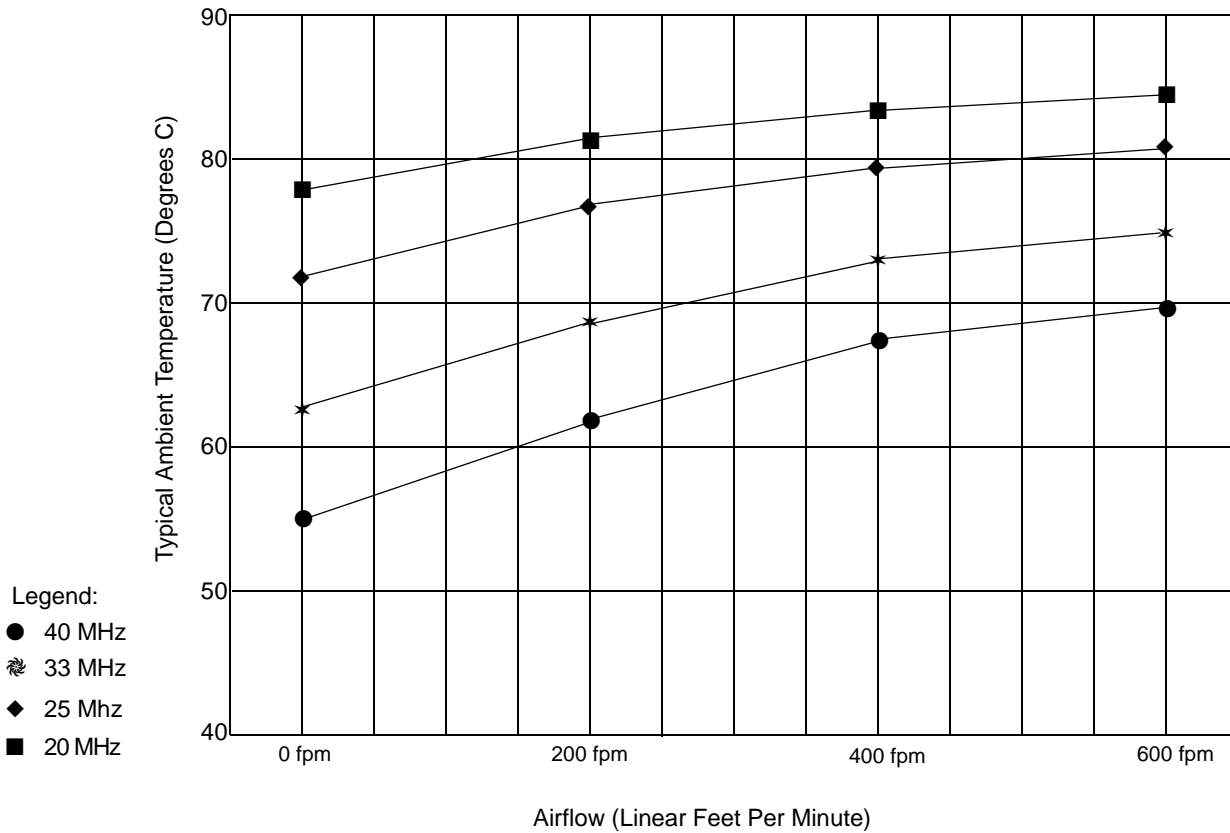
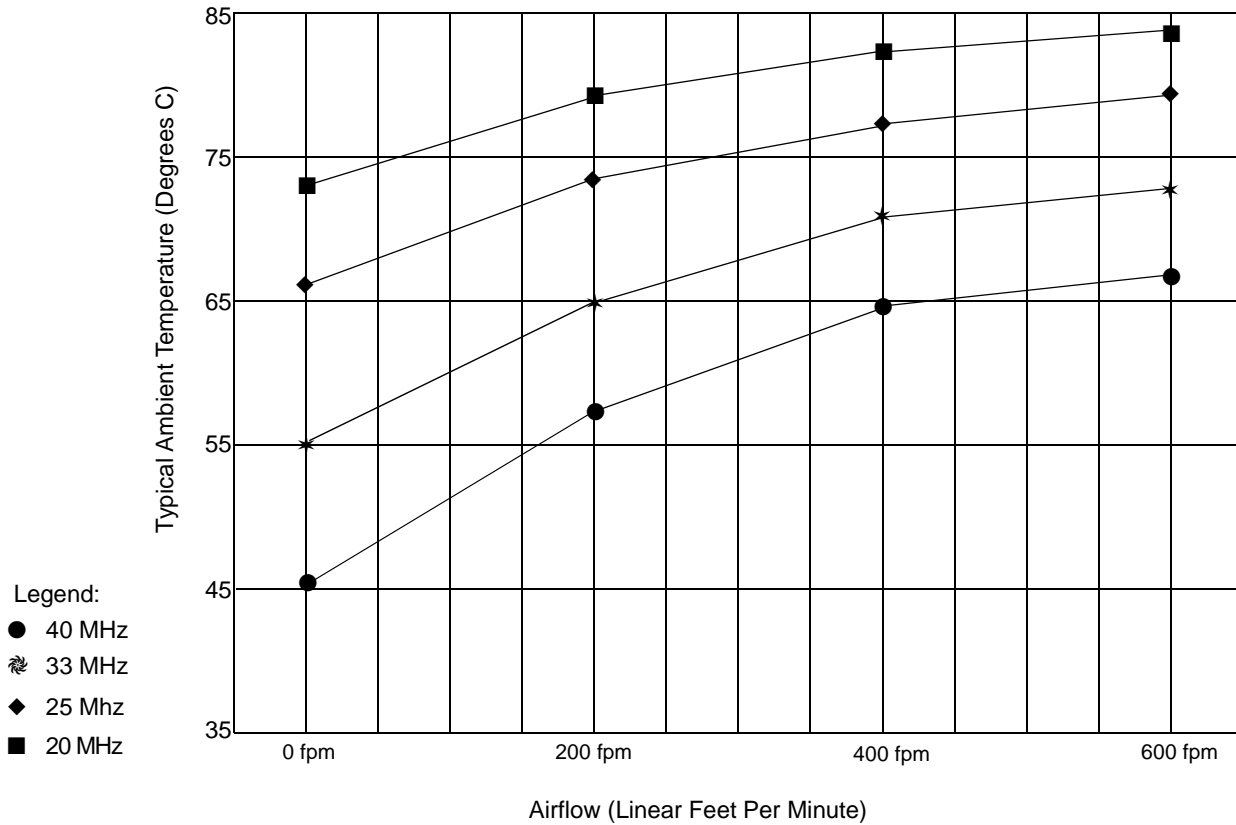

**Figure 15. Typical Ambient Temperatures for PQFP with a 2-Layer Board**

Table 15 shows typical maximum ambient temperatures in degrees Centigrade for a TQFP package used on a 2-layer board. The typical ambient temperatures are based on a 100-degree Centigrade maximum case temperature. Figure 16 graphically illustrates the typical temperatures in Table 15.

**Table 15. Typical Ambient Temperatures (°C) for TQFP with a 2-Layer Board**

Microcontroller Speed	Typical Power (Watts)	Linear Feet per Minute Airflow			
		0 fpm	200 fpm	400 fpm	600 fpm
40 MHz	1.2	45.7	57.5	64.6	67.0
33 MHz	1.0	55.2	65.0	70.8	72.7
25 MHz	0.7	66.1	73.5	77.9	79.4
20 MHz	0.6	72.9	78.8	82.3	83.5



**Figure 16. Typical Ambient Temperatures for TQFP with a 2-Layer Board**



Table 16 shows typical maximum ambient temperatures in degrees Centigrade for a PQFP package used on a 4-layer to 6-layer board. The typical ambient temperatures are based on a 100-degree Centigrade maximum case temperature. Figure 17 graphically illustrates the typical temperatures in Table 16.

**Table 16. Typical Ambient Temperatures (°C) for PQFP with a 4-Layer to 6-Layer Board**

Microcontroller Speed	Typical Power (Watts)	Linear Feet per Minute Airflow			
		0 fpm	200 fpm	400 fpm	600 fpm
40 MHz	1.2	78.8	81.1	83.5	85.8
33 MHz	1.0	82.5	84.4	86.4	88.3
25 MHz	0.7	86.7	88.2	89.7	91.2
20 MHz	0.6	89.4	90.6	91.7	92.9

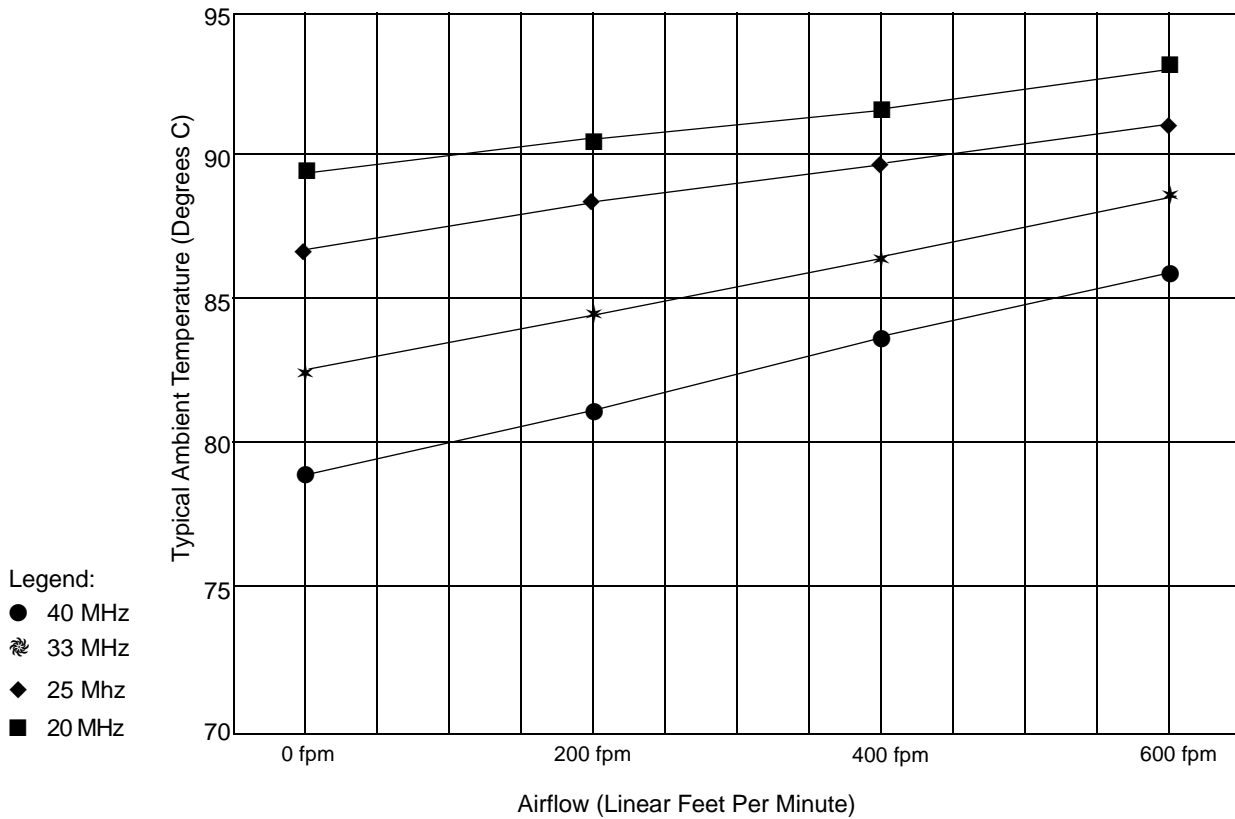
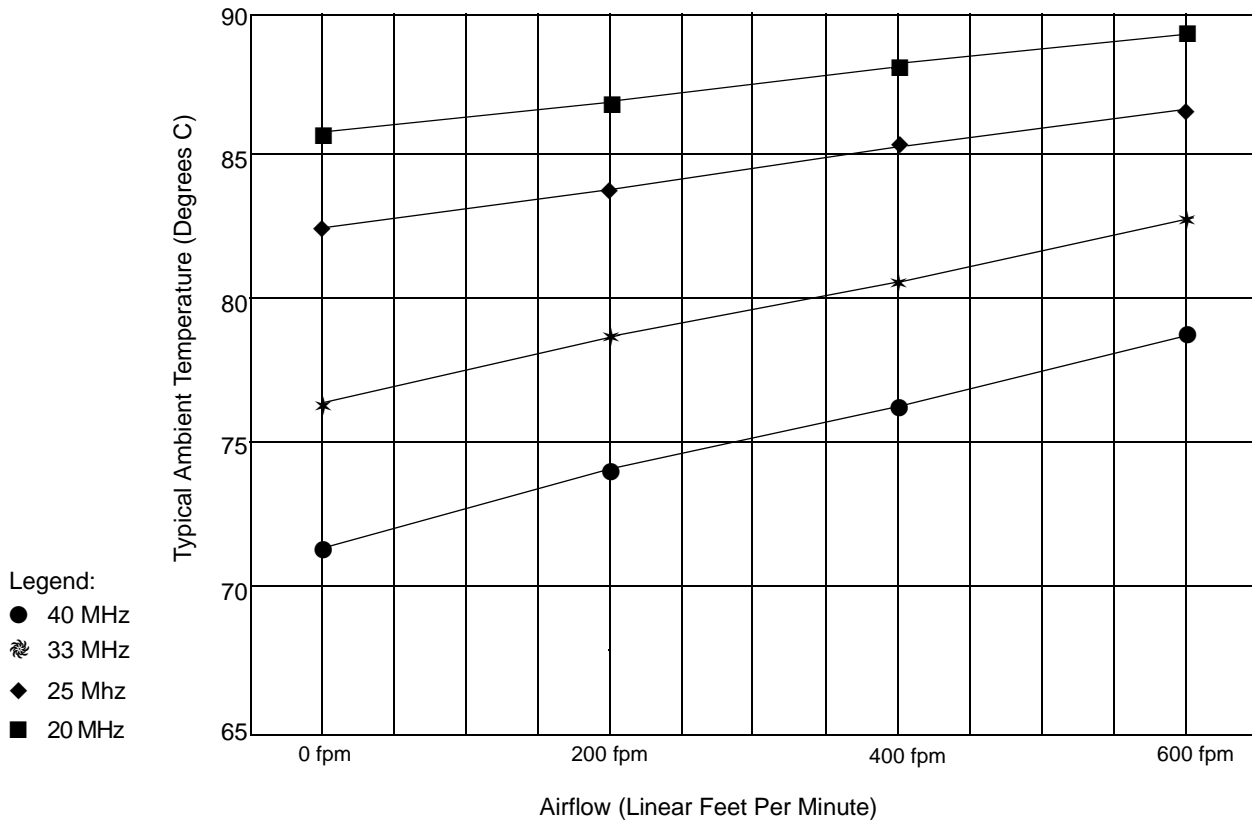

**Figure 17. Typical Ambient Temperatures for PQFP with a 4-Layer to 6-Layer Board**

Table 17 shows typical maximum ambient temperatures in degrees Centigrade for a TQFP package used on a 4-layer to 6-layer board. The typical ambient temperatures are based on a 100-degree Centigrade maximum case temperature. Figure 18 graphically illustrates the typical temperatures in Table 17.

**Table 17. Typical Ambient Temperatures (°C) for TQFP with a 4-Layer to 6-Layer Board**

Microcontroller Speed	Typical Power (Watts)	Linear Feet per Minute Airflow			
		0 fpm	200 fpm	400 fpm	600 fpm
40 MHz	1.2	71.7	74.0	76.4	78.8
33 MHz	1.0	76.6	78.6	80.5	82.5
25 MHz	0.7	82.3	83.8	85.3	86.7
20 MHz	0.6	85.8	87.0	88.2	89.4



**Figure 18. Typical Ambient Temperatures for TQFP with a 4-Layer to 6-Layer Board**

## COMMERCIAL AND INDUSTRIAL SWITCHING CHARACTERISTICS AND WAVEFORMS

In the switching waveforms that follow, several abbreviations are used to indicate the specific periods of a bus cycle. These periods are referred to as time states. A typical bus cycle is composed of four consecutive time states:  $t_1$ ,  $t_2$ ,  $t_3$ , and  $t_4$ . Wait states, which represent multiple  $t_3$  states, are referred to as  $t_w$

states. When no bus cycle is pending, an idle ( $t_i$ ) state occurs.

In the switching parameter descriptions, the *multiplexed* address is referred to as the AD address bus; the *demultiplexed* address is referred to as the A address bus.

### Key to Switching Waveforms

WAVEFORM	INPUT	OUTPUT
	Must be Steady	Will be Steady
	May Change from H to L	Will be Changing from H to L
	May Change from L to H	Will be Changing from L to H
	Don't Care, Any Change Permitted	Changing, State Unknown
	Does Not Apply	Center Line is High-Impedance Off State
	Invalid	Invalid

## Alphabetical Key to Switching Parameter Symbols

Parameter Symbol	No.	Description
$t_{\text{ARYCH}}$	49	ARDY Resolution Transition Setup Time
$t_{\text{ARYCHL}}$	51	ARDY Inactive Holding Time
$t_{\text{ARYHDSH}}^{(a)}$	95	ARDY High to $\overline{\text{DS}}$ High
$t_{\text{ARYHDV}}^{(a)}$	89	ARDY Assert to Data Valid
$t_{\text{ARYLCL}}$	52	ARDY Setup Time
$t_{\text{ARYLDSH}}^{(a)}$	96	ARDY Low to $\overline{\text{DS}}$ High
$t_{\text{AVBL}}$	87	A Address Valid to $\overline{\text{WHB}}$ , $\overline{\text{WLB}}$ Low
$t_{\text{AVCH}}$	14	AD Address Valid to Clock High
$t_{\text{AVLL}}$	12	AD Address Valid to ALE Low
$t_{\text{AVRL}}$	66	A Address Valid to $\overline{\text{RD}}$ Low
$t_{\text{AVWL}}$	65	A Address Valid to $\overline{\text{WR}}$ Low
$t_{\text{AZRL}}$	24	AD Address Float to $\overline{\text{RD}}$ Active
$t_{\text{CH1CH2}}$	45	CLKOUTA Rise Time
$t_{\text{CHAV}}$	68	CLKOUTA High to A Address Valid
$t_{\text{CHCA}}$	104	CLKOUTA High to $\overline{\text{CAS}}$ Active
$t_{\text{CHCAV}}$	101	CLKOUTA Low to Column Address Valid
$t_{\text{CHCK}}$	38	X1 High Time
$t_{\text{CHCL}}$	44	CLKOUTA High Time
$t_{\text{CHCSV}}$	67	CLKOUTA High to $\overline{\text{LCS}}/\overline{\text{UCS}}$ Valid
$t_{\text{CHCSX}}$	18	$\overline{\text{MCS}}/\overline{\text{PCS}}$ Inactive Delay
$t_{\text{CHCTV}}$	22	Control Active Delay 2
$t_{\text{CHCV}}$	64	Command Lines Valid Delay (after Float)
$t_{\text{CHCZ}}$	63	Command Lines Float Delay
$t_{\text{CHDX}}$	8	Status Hold Time
$t_{\text{CHLH}}$	9	ALE Active Delay
$t_{\text{CHLL}}$	11	ALE Inactive Delay
$t_{\text{CHRA}}$	106	CLKOUTA High to $\overline{\text{RAS}}$ Active
$t_{\text{CHSV}}$	3	Status Active Delay
$t_{\text{CICOA}}$	69	X1 to CLKOUTA Skew
$t_{\text{CICOB}}$	70	X1 to CLKOUTB Skew
$t_{\text{CHRX}}$	103	CLKOUTA High to $\overline{\text{RAS}}$ Inactive
$t_{\text{CKHL}}$	39	X1 Fall Time
$t_{\text{CKIN}}$	36	X1 Period
$t_{\text{CKLH}}$	40	X1 Rise Time
$t_{\text{CL2CL1}}$	46	CLKOUTA Fall Time
$t_{\text{CLARX}}$	50	ARDY Active Hold Time
$t_{\text{CLAV}}$	5	AD Address Valid Delay and BHE
$t_{\text{CLAX}}$	6	Address Hold
$t_{\text{CLAZ}}$	15	AD Address Float Delay
$t_{\text{CLCH}}$	43	CLKOUTA Low Time
$t_{\text{CLCK}}$	37	X1 Low Time
$t_{\text{CLCL}}$	42	CLKOUTA Period

## Alphabetical Key to Switching Parameter Symbols (continued)

Parameter Symbol	No.	Description
$t_{CLCSV}$	16	$\overline{MCS}/\overline{PCS}$ Active Delay
$t_{CLCX}$	105	CLKOUTA Low to $\overline{CAS}$ Inactive
$t_{CLR X}$	107	CLKOUTA Low to $\overline{RAS}$ Inactive
$t_{CLDOX}$	30	Data Hold Time
$t_{CLDV}$	7	Data Valid Delay
$t_{CLDX}$	2	Data in Hold
$t_{CLHAV}$	62	HLDA Valid Delay
$t_{CLRA}$	102	CLKOUTA Low to $\overline{RAS}$ Active
$t_{CLR H}$	27	$\overline{RD}$ Inactive Delay
$t_{CLR L}$	25	$\overline{RD}$ Active Delay
$t_{CLSH}$	4	Status Inactive Delay
$t_{CLSR Y}$	48	SRDY Transition Hold Time
$t_{CLTMV}$	55	Timer Output Delay
$t_{COAOB}^{(a)}$	83	CLKOUTA to CLKOUTB Skew
$t_{CSHARYL}^{(a)}$	88	Chip Select to ARDY Low
$t_{CVCTV}$	20	Control Active Delay 1
$t_{CVCTX}$	31	Control Inactive Delay
$t_{CVDEX}$	21	$\overline{DEN}$ Inactive Delay
$t_{CXCSX}$	17	$\overline{MCS}/\overline{PCS}$ Hold from Command Inactive
$t_{DSHDIR}^{(a)}$	92	$\overline{DS}$ High to Data Invalid—Read
$t_{DSHDIW}$	98	$\overline{DS}$ High to Data Invalid—Write
$t_{DSHDX}^{(a)}$	93	$\overline{DS}$ High to Data Bus Turn-off Time
$t_{DShLH}$	41	$\overline{DS}$ Inactive to ALE Inactive
$t_{DSLDD}^{(a)}$	90	$\overline{DS}$ Low to Data Driven
$t_{DSL DV}^{(a)}$	91	$\overline{DS}$ Low to Data Valid
$t_{DVCL}$	1	Data in Setup
$t_{DVDSL}^{(a)}$	97	Data Valid to $\overline{DS}$ Low
$t_{DXDL}$	19	$\overline{DEN}$ Inactive to DT/ $\overline{R}$ Low
$t_{HVCL}$	58	HOLD Setup
$t_{INVCH}$	53	Peripheral Setup Time
$t_{INVCL}$	54	DRQ Setup Time
$t_{LHAV}$	23	ALE High to Address Valid
$t_{LHLL}$	10	ALE Width
$t_{LLAX}$	13	AD Address Hold from ALE Inactive
$t_{LOCK}$	61	Maximum PLL Lock Time
$t_{PLAL}$	99	$\overline{PCS}$ Active to ALE Inactive
$t_{RD0W}$	110	$\overline{RAS}$ To Column Address Delay Time with 0 Wait States
$t_{RD1W}$	111	$\overline{RAS}$ to Column Address Delay Time with 1 or More Wait States
$t_{RESIN}$	57	$\overline{RES}$ Setup Time
$t_{RHAV}$	29	$\overline{RD}$ Inactive to AD Address Active
$t_{RHD X}$	59	$\overline{RD}$ High to Data Hold on AD Bus
$t_{RHDZ}^{(a)}$	94	$\overline{RD}$ High to Data Bus Turn-off Time
$t_{RHLH}$	28	$\overline{RD}$ Inactive to ALE High

## Alphabetical Key to Switching Parameter Symbols (continued)

Parameter Symbol	No.	Description
$t_{RLRH}$	26	$\overline{RD}$ Pulse Width
$t_{RP0W}$	108	$\overline{RAS}$ Inactive Pulse Width (0 Wait States)
$t_{RP1W}$	109	$\overline{RAS}$ Inactive Pulse Width (1 Wait State)
$t_{SRYCL}$	47	SRDY Transition Setup Time
$t_{WHDEX}$	35	$\overline{WR}$ Inactive to $\overline{DEN}$ Inactive
$t_{WHDX}$	34	Data Hold after $\overline{WR}$
$t_{WHLH}$	33	$\overline{WR}$ Inactive to ALE High
$t_{WLWH}$	32	$\overline{WR}$ Pulse Width

**Note:**

a Specs 83 and 88–97 are defined but not used at this time. Additionally, the following parameters are not defined nor used at this time: 56, 60, and 71–78.



## Numerical Key to Switching Parameter Symbols

No.	Parameter Symbol	Description
1	$t_{DVCL}$	Data in Setup
2	$t_{CLDX}$	Data in Hold
3	$t_{CHSV}$	Status Active Delay
4	$t_{CLSH}$	Status Inactive Delay
5	$t_{CLAV}$	AD Address Valid Delay and BHE
6	$t_{CLAX}$	Address Hold
7	$t_{CLDV}$	Data Valid Delay
8	$t_{CHDX}$	Status Hold Time
9	$t_{CHLH}$	ALE Active Delay
10	$t_{LHLL}$	ALE Width
11	$t_{CHLL}$	ALE Inactive Delay
12	$t_{AVLL}$	AD Address Valid to ALE Low
13	$t_{LLAX}$	AD Address Hold from ALE Inactive
14	$t_{AVCH}$	AD Address Valid to Clock High
15	$t_{CLAZ}$	AD Address Float Delay
16	$t_{CLCSV}$	$\overline{MCS}/\overline{PCS}$ Active Delay
17	$t_{CXCSX}$	$\overline{MCS}/\overline{PCS}$ Hold from Command Inactive
18	$t_{CHCSX}$	$\overline{MCS}/\overline{PCS}$ Inactive Delay
19	$t_{DXDL}$	$\overline{DEN}$ Inactive to $\overline{DT}/\overline{R}$ Low
20	$t_{CVCTV}$	Control Active Delay 1
21	$t_{CVDEX}$	$\overline{DEN}$ Inactive Delay
22	$t_{CHCTV}$	Control Active Delay 2
23	$t_{LHAV}$	ALE High to Address Valid
24	$t_{AZRL}$	AD Address Float to $\overline{RD}$ Active
25	$t_{CLRL}$	$\overline{RD}$ Active Delay
26	$t_{RLRH}$	$\overline{RD}$ Pulse Width
27	$t_{CLRH}$	$\overline{RD}$ Inactive Delay
28	$t_{RHLH}$	$\overline{RD}$ Inactive to ALE High
29	$t_{RHAV}$	$\overline{RD}$ Inactive to AD Address Active
30	$t_{CLDOX}$	Data Hold Time
31	$t_{CVCTX}$	Control Inactive Delay
32	$t_{WLWH}$	$\overline{WR}$ Pulse Width
33	$t_{WHLH}$	$\overline{WR}$ Inactive to ALE High
34	$t_{WHDX}$	Data Hold after $\overline{WR}$
35	$t_{WHDEX}$	$\overline{WR}$ Inactive to $\overline{DEN}$ Inactive
36	$t_{CKIN}$	X1 Period
37	$t_{CLCK}$	X1 Low Time
38	$t_{CHCK}$	X1 High Time
39	$t_{CKHL}$	X1 Fall Time
40	$t_{CKLH}$	X1 Rise Time
41	$t_{DSHLH}$	$\overline{DS}$ Inactive to ALE Inactive
42	$t_{CLCL}$	CLKOUTA Period

## Numerical Key to Switching Parameter Symbols (continued)

No.	Parameter Symbol	Description
43	$t_{CLCH}$	CLKOUTA Low Time
44	$t_{CHCL}$	CLKOUTA High Time
45	$t_{CH1CH2}$	CLKOUTA Rise Time
46	$t_{CL2CL1}$	CLKOUTA Fall Time
47	$t_{SRVCL}$	SRDY Transition Setup Time
48	$t_{CLSRV}$	SRDY Transition Hold Time
49	$t_{ARVCH}$	ARDY Resolution Transition Setup Time
50	$t_{CLARX}$	ARDY Active Hold Time
51	$t_{ARVCHL}$	ARDY Inactive Holding Time
52	$t_{ARVCL}$	ARDY Setup Time
53	$t_{INVCH}$	Peripheral Setup Time
54	$t_{INVCL}$	DRQ Setup Time
55	$t_{CLTMV}$	Timer Output Delay
57	$t_{RESIN}$	$\overline{RES}$ Setup Time
58	$t_{HVCL}$	HOLD Setup
59	$t_{RHDX}$	$\overline{RD}$ High to Data Hold on AD Bus
61	$t_{LOCK}$	Maximum PLL Lock Time
62	$t_{CLHAV}$	HLDA Valid Delay
63	$t_{CHCZ}$	Command Lines Float Delay
64	$t_{CHCV}$	Command Lines Valid Delay (after Float)
65	$t_{AVWL}$	A Address Valid to $\overline{WR}$ Low
66	$t_{AVRL}$	A Address Valid to $\overline{RD}$ Low
67	$t_{CHCSV}$	CLKOUTA High to $\overline{LCS}/\overline{UCS}$ Valid
68	$t_{CHAV}$	CLKOUTA High to A Address Valid
69	$t_{CICOA}$	X1 to CLKOUTA Skew
70	$t_{CICOB}$	X1 to CLKOUTB Skew
83 <sup>(a)</sup>	$t_{COAOB}$	CLKOUTA to CLKOUTB Skew
87	$t_{AVBL}$	A Address Valid to $\overline{WHB}$ , $\overline{WLB}$ Low
88 <sup>(a)</sup>	$t_{CSHARYL}$	Chip Select to ARDY Low
89 <sup>(a)</sup>	$t_{ARVHDV}$	ARDY Assert to Data Valid
90 <sup>(a)</sup>	$t_{DSLDD}$	$\overline{DS}$ Low to Data Driven
91 <sup>(a)</sup>	$t_{DSL DV}$	$\overline{DS}$ Low to Data Valid
92 <sup>(a)</sup>	$t_{DSHDIR}$	$\overline{DS}$ High to Data Invalid—Read
93 <sup>(a)</sup>	$t_{DSHDX}$	$\overline{DS}$ High to Data Bus Turn-off Time

## Numerical Key to Switching Parameter Symbols (continued)

No.	Parameter Symbol	Description
94 <sup>(a)</sup>	$t_{\text{RHDZ}}$	$\overline{\text{RD}}$ High to Data Bus Turn-off Time
95 <sup>(a)</sup>	$t_{\text{ARYHDSH}}$	ARDY High to $\overline{\text{DS}}$ High
96 <sup>(a)</sup>	$t_{\text{ARYLDSH}}$	ARDY Low to $\overline{\text{DS}}$ High
97 <sup>(a)</sup>	$t_{\text{DVDSL}}$	Data Valid to $\overline{\text{DS}}$ Low
98	$t_{\text{DSHDIW}}$	$\overline{\text{DS}}$ High to Data Invalid—Write
99	$t_{\text{PLAL}}$	$\overline{\text{PCS}}$ Active to ALE Inactive
101	$t_{\text{CHCAV}}$	CLKOUTA Low to Column Address Valid
102	$t_{\text{CLRA}}$	CLKOUTA Low to $\overline{\text{RAS}}$ Active
103	$t_{\text{CHRX}}$	CLKOUTA High to $\overline{\text{RAS}}$ Inactive
104	$t_{\text{CHCA}}$	CLKOUTA High to $\overline{\text{CAS}}$ Active
105	$t_{\text{CLCX}}$	CLKOUTA Low to $\overline{\text{CAS}}$ Inactive
106	$t_{\text{CHRA}}$	CLKOUTA High to $\overline{\text{RAS}}$ Active
107	$t_{\text{CLR X}}$	CLKOUTA Low to $\overline{\text{RAS}}$ Inactive
108	$t_{\text{RP0W}}$	$\overline{\text{RAS}}$ Inactive Pulse Width (0 Wait States)
109	$t_{\text{RP1W}}$	$\overline{\text{RAS}}$ Inactive Pulse Width (1 Wait State)
110	$t_{\text{RD0W}}$	$\overline{\text{RAS}}$ To Column Address Delay Time with 0 Wait States
111	$t_{\text{RD1W}}$	$\overline{\text{RAS}}$ to Column Address Delay Time with 1 or More Wait States

**Note:**

a Specs 83 and 88–97 are defined but not used at this time. Additionally, the following parameters are not defined nor used at this time: 56, 60, and 71–78.

## SWITCHING CHARACTERISTICS over COMMERCIAL and INDUSTRIAL operating ranges

### Read Cycle (20 MHz and 25 MHz)

Parameter			Preliminary				Unit
			20 MHz		25 MHz		
No.	Symbol	Description	Min	Max	Min	Max	Unit
<b>General Timing Requirements</b>							
1	t <sub>DVCL</sub>	Data in Setup	10		10		ns
2	t <sub>CLDX</sub>	Data in Hold <sup>(c)</sup>	3		3		ns
<b>General Timing Responses</b>							
3	t <sub>CHSV</sub>	Status Active Delay	0	25	0	20	ns
4	t <sub>CLSH</sub>	Status Inactive Delay	0	25	0	20	ns
5	t <sub>CLAV</sub>	AD Address Valid Delay and BHE	0	25	0	20	ns
6	t <sub>CLAX</sub>	Address Hold	0	25	0	20	ns
8	t <sub>CHDX</sub>	Status Hold Time	0		0		ns
9	t <sub>CHLH</sub>	ALE Active Delay		25		20	ns
10	t <sub>LHLL</sub>	ALE Width	t <sub>CLCL</sub> -10=40		t <sub>CLCL</sub> -10=30		ns
11	t <sub>CHLL</sub>	ALE Inactive Delay		25		20	ns
12	t <sub>AVLL</sub>	AD Address Valid to ALE Low <sup>(a)</sup>	t <sub>CLCH</sub> -2		t <sub>CLCH</sub> -2		ns
13	t <sub>LLAX</sub>	AD Address Hold from ALE Inactive <sup>(a)</sup>	t <sub>CHCL</sub> -2		t <sub>CHCL</sub> -2		ns
14	t <sub>AVCH</sub>	AD Address Valid to Clock High	0		0		ns
15	t <sub>CLAZ</sub>	AD Address Float Delay	t <sub>CLAX</sub> =0	25	t <sub>CLAX</sub> =0	20	ns
16	t <sub>CLCSV</sub>	$\overline{\text{MCS}}/\overline{\text{PCS}}$ Active Delay	0	25	0	20	ns
17	t <sub>CXCSX</sub>	$\overline{\text{MCS}}/\overline{\text{PCS}}$ Hold from Command Inactive <sup>(a)</sup>	t <sub>CLCH</sub> -2		t <sub>CLCH</sub> -2		ns
18	t <sub>CHCSX</sub>	$\overline{\text{MCS}}/\overline{\text{PCS}}$ Inactive Delay	0	25	0	20	ns
19	t <sub>DXDL</sub>	$\overline{\text{DEN}}$ Inactive to DT/ $\overline{\text{R}}$ Low <sup>(a)</sup>	0		0		ns
20	t <sub>CVCTV</sub>	Control Active Delay 1 <sup>(b)</sup>	0	25	0	20	ns
21	t <sub>CVDEX</sub>	$\overline{\text{DEN}}$ Inactive Delay	0	25	0	20	ns
22	t <sub>CHCTV</sub>	Control Active Delay 2 <sup>(b)</sup>	0	25	0	20	ns
23	t <sub>LHAV</sub>	ALE High to Address Valid	20		15		ns
99	t <sub>PLAL</sub>	$\overline{\text{PCS}}$ Active to ALE Inactive	15	28	15	24	ns
<b>Read Cycle Timing Responses</b>							
24	t <sub>AZRL</sub>	AD Address Float to $\overline{\text{RD}}$ Active	0		0		ns
25	t <sub>CLRL</sub>	$\overline{\text{RD}}$ Active Delay	0	25	0	20	ns
26	t <sub>RLRH</sub>	$\overline{\text{RD}}$ Pulse Width	2t <sub>CLCL</sub> -15=85		2t <sub>CLCL</sub> -15=65		ns
27	t <sub>CLRH</sub>	$\overline{\text{RD}}$ Inactive Delay	0	25	0	20	ns
28	t <sub>RHLH</sub>	$\overline{\text{RD}}$ Inactive to ALE High <sup>(a)</sup>	t <sub>CLCH</sub> -3		t <sub>CLCH</sub> -3		ns
29	t <sub>RHAV</sub>	$\overline{\text{RD}}$ Inactive to AD Address Active <sup>(a)</sup>	t <sub>CLCL</sub> -10=40		t <sub>CLCL</sub> -10=30		ns
41	t <sub>DShLH</sub>	$\overline{\text{DS}}$ Inactive to ALE Active	t <sub>CLCH</sub> -2=21		t <sub>CLCH</sub> -2=16		ns
59	t <sub>RHDx</sub>	$\overline{\text{RD}}$ High to Data Hold on AD Bus <sup>(c)</sup>	0		0		ns
66	t <sub>AVRL</sub>	A Address Valid to $\overline{\text{RD}}$ Low <sup>(a)</sup>	t <sub>CLCL</sub> + t <sub>CHCL</sub> -3		t <sub>CLCL</sub> + t <sub>CHCL</sub> -3		ns
67	t <sub>CHCSV</sub>	CLKOUTA High to $\overline{\text{LCS}}/\overline{\text{UCS}}$ Valid	0	25	0	20	ns
68	t <sub>CHAV</sub>	CLKOUTA High to A Address Valid	0	25	0	20	ns

**Notes:**

All timing parameters are measured at 1.5 V with 50 pF loading on CLKOUTA, unless otherwise noted. All output test conditions are with C<sub>L</sub>=50 pF. For switching tests, V<sub>IL</sub>=0.45 V and V<sub>IH</sub>=2.4 V, except at X1 where V<sub>IH</sub>=V<sub>CC</sub> - 0.5 V.

a Equal loading on referenced pins.

b This parameter applies to the  $\overline{\text{DEN}}$ ,  $\overline{\text{DS}}$ ,  $\overline{\text{INTA1}}-\overline{\text{INTA0}}$ ,  $\overline{\text{WR}}$ ,  $\overline{\text{WHB}}$ , and  $\overline{\text{WLB}}$  signals.

c If either spec 2 or spec 59 is met with respect to data hold time, the part will function correctly.

## SWITCHING CHARACTERISTICS over COMMERCIAL operating ranges

### Read Cycle (33 MHz and 40 MHz)

Parameter			Preliminary				Unit
			33 MHz		40 MHz		
No.	Symbol	Description	Min	Max	Min	Max	Unit
<b>General Timing Requirements</b>							
1	t <sub>DVCL</sub>	Data in Setup	8		5		ns
2	t <sub>CLDX</sub>	Data in Hold <sup>(c)</sup>	3		2		ns
<b>General Timing Responses</b>							
3	t <sub>CHSV</sub>	Status Active Delay	0	15	0	12	ns
4	t <sub>CLSH</sub>	Status Inactive Delay	0	15	0	12	ns
5	t <sub>CLAV</sub>	AD Address Valid Delay and BHE	0	15	0	12	ns
6	t <sub>CLAX</sub>	Address Hold	0	15	0	12	ns
8	t <sub>CHDX</sub>	Status Hold Time	0		0		ns
9	t <sub>CHLH</sub>	ALE Active Delay		15		12	ns
10	t <sub>LHLL</sub>	ALE Width	t <sub>CLCL</sub> -10=20		t <sub>CLCL</sub> -5=20		ns
11	t <sub>CHLL</sub>	ALE Inactive Delay		15		12	ns
12	t <sub>AVLL</sub>	AD Address Valid to ALE Low <sup>(a)</sup>	t <sub>CLCH</sub> -2		t <sub>CLCH</sub> -2		ns
13	t <sub>LLAX</sub>	AD Address Hold from ALE Inactive <sup>(a)</sup>	t <sub>CHCL</sub> -2		t <sub>CHCL</sub> -2		ns
14	t <sub>AVCH</sub>	AD Address Valid to Clock High	0		0		ns
15	t <sub>CLAZ</sub>	AD Address Float Delay	t <sub>CLAX</sub> =0	15	t <sub>CLAX</sub> =0	12	ns
16	t <sub>CLCSV</sub>	$\overline{\text{MCS/PCS}}$ Active Delay	0	15	0	12	ns
17	t <sub>CXCSX</sub>	$\overline{\text{MCS/PCS}}$ Hold from Command Inactive <sup>(a)</sup>	t <sub>CLCH</sub> -2		t <sub>CLCH</sub> -2		ns
18	t <sub>CHCSX</sub>	$\overline{\text{MCS/PCS}}$ Inactive Delay	0	15	0	12	ns
19	t <sub>DXDL</sub>	$\overline{\text{DEN}}$ Inactive to DT/ $\overline{\text{R}}$ Low <sup>(a)</sup>	0		0		ns
20	t <sub>CVCTV</sub>	Control Active Delay 1 <sup>(b)</sup>	0	15	0	12	ns
21	t <sub>CVDEX</sub>	$\overline{\text{DEN}}$ Inactive Delay	0	15	0	12	ns
22	t <sub>CHCTV</sub>	Control Active Delay 2 <sup>(b)</sup>	0	15	0	12	ns
23	t <sub>LHAV</sub>	ALE High to Address Valid	10		7.5		ns
99	t <sub>PLAL</sub>	$\overline{\text{PCS}}$ Active to ALE Inactive	12	20	10	18	ns
<b>Read Cycle Timing Responses</b>							
24	t <sub>AZRL</sub>	AD Address Float to $\overline{\text{RD}}$ Active	0		0		ns
25	t <sub>CLRL</sub>	$\overline{\text{RD}}$ Active Delay	0	15	0	10	ns
26	t <sub>RLRH</sub>	$\overline{\text{RD}}$ Pulse Width	2t <sub>CLCL</sub> -15=45		2t <sub>CLCL</sub> -10=40		ns
27	t <sub>CLRH</sub>	$\overline{\text{RD}}$ Inactive Delay	0	15	0	12	ns
28	t <sub>RHLH</sub>	$\overline{\text{RD}}$ Inactive to ALE High <sup>(a)</sup>	t <sub>CLCH</sub> -3		t <sub>CLCH</sub> -2		ns
29	t <sub>RHAV</sub>	$\overline{\text{RD}}$ Inactive to AD Address Active <sup>(a)</sup>	t <sub>CLCL</sub> -10=20		t <sub>CLCL</sub> -5=20		ns
41	t <sub>DSHLH</sub>	$\overline{\text{DS}}$ Inactive to ALE Active	t <sub>CLCH</sub> -2=11.5		t <sub>CLCH</sub> -2=9.25		ns
59	t <sub>RHDX</sub>	$\overline{\text{RD}}$ High to Data Hold on AD Bus <sup>(c)</sup>	0		0		ns
66	t <sub>AVRL</sub>	A Address Valid to $\overline{\text{RD}}$ Low <sup>(a)</sup>	t <sub>CLCL</sub> +t <sub>CHCL</sub> -3		t <sub>CLCL</sub> +t <sub>CHCL</sub> -1.25		ns
67	t <sub>CHCSV</sub>	CLKOUTA High to $\overline{\text{LCS/UCS}}$ Valid	0	15	0	10	ns
68	t <sub>CHAV</sub>	CLKOUTA High to A Address Valid	0	15	0	10	ns

**Notes:**

All timing parameters are measured at 1.5 V with 50 pF loading on CLKOUTA, unless otherwise noted. All output test conditions are with C<sub>L</sub>=50 pF. For switching tests, V<sub>IL</sub>=0.45 V and V<sub>IH</sub>=2.4 V, except at X1 where V<sub>IH</sub>=V<sub>CC</sub>-0.5 V.

a Equal loading on referenced pins.

b This parameter applies to the  $\overline{\text{DEN}}$ ,  $\overline{\text{DS}}$ ,  $\overline{\text{INTA1}}-\overline{\text{INTA0}}$ ,  $\overline{\text{WR}}$ ,  $\overline{\text{WHB}}$ , and  $\overline{\text{WLB}}$  signals.

c If either spec 2 or spec 59 is met with respect to data hold time, the part will function correctly.

READ CYCLE WAVEFORMS

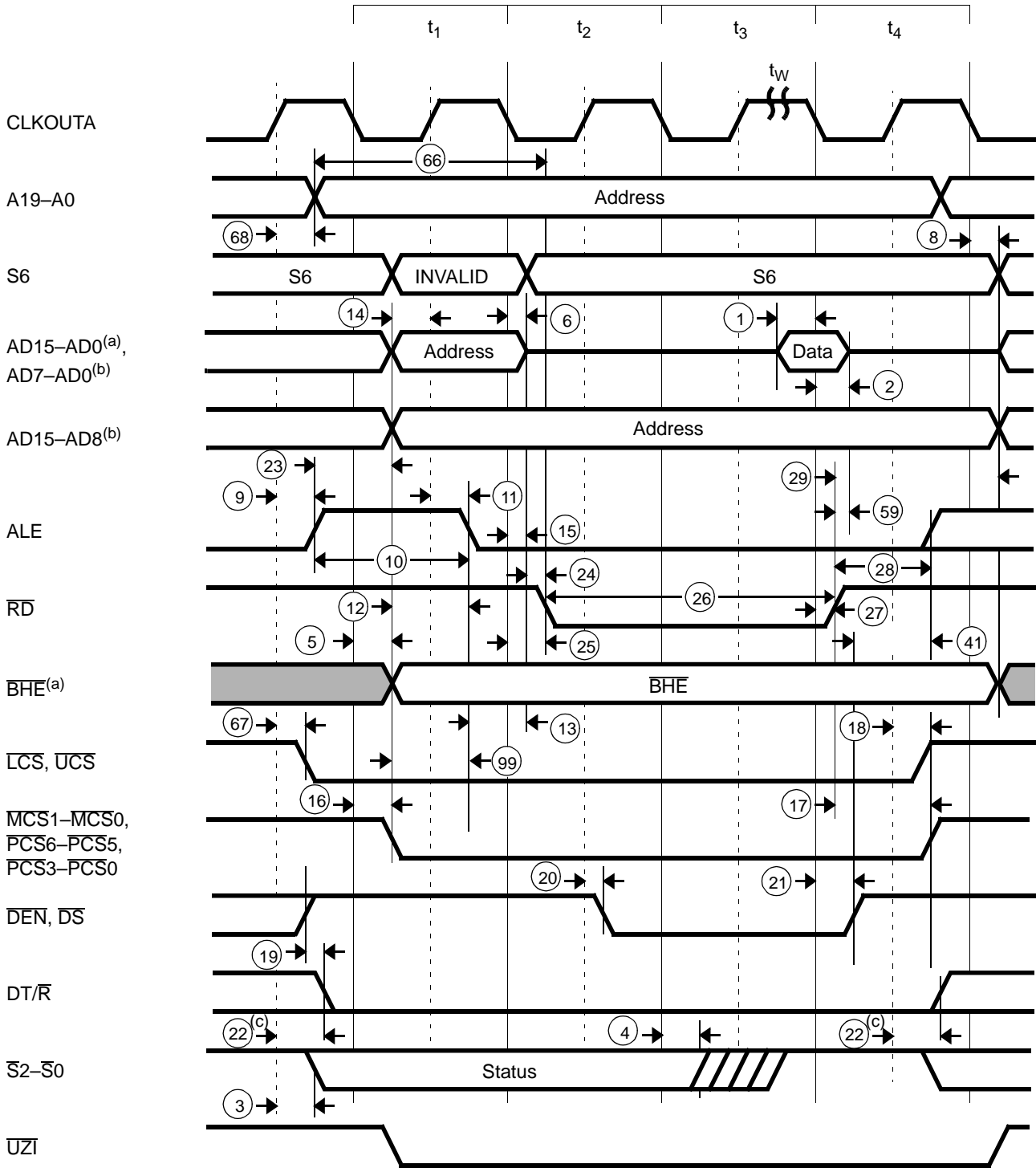

Notes:

- a Am186ED/EDLV microcontrollers in 16-bit mode
- b Am186ED/EDLV microcontrollers in 8-bit mode
- c Changes in  $t$  phase preceding next bus cycle if followed by read, INTA, or halt.



## SWITCHING CHARACTERISTICS over COMMERCIAL and INDUSTRIAL operating ranges

### Write Cycle (20 MHz and 25 MHz)

Parameter			Preliminary				Unit
			20 MHz		25 MHz		
No.	Symbol	Description	Min	Max	Min	Max	Unit
<b>General Timing Responses</b>							
3	t <sub>CHSV</sub>	Status Active Delay	0	25	0	20	ns
4	t <sub>CLSH</sub>	Status Inactive Delay	0	25	0	20	ns
5	t <sub>CLAV</sub>	AD Address Valid Delay and BHE	0	25	0	20	ns
6	t <sub>CLAX</sub>	Address Hold	0	25	0	20	ns
7	t <sub>CLDV</sub>	Data Valid Delay	0	15	0	15	ns
8	t <sub>CHDX</sub>	Status Hold Time	0		0		ns
9	t <sub>CHLH</sub>	ALE Active Delay		25		20	ns
10	t <sub>LHLL</sub>	ALE Width	t <sub>CLCL</sub> -10=40		t <sub>CLCL</sub> -10=30		ns
11	t <sub>CHLL</sub>	ALE Inactive Delay		25		20	ns
12	t <sub>AVLL</sub>	AD Address Valid to ALE Low <sup>(a)</sup>	t <sub>CLCH</sub> -2		t <sub>CLCH</sub> -2		ns
13	t <sub>LLAX</sub>	AD Address Hold from ALE Inactive <sup>(a)</sup>	t <sub>CHCL</sub> -2		t <sub>CHCL</sub> -2		ns
14	t <sub>AVCH</sub>	AD Address Valid to Clock High	0		0		ns
16	t <sub>CLCSV</sub>	MCS/PCS Active Delay	0	25	0	20	ns
17	t <sub>CXCSX</sub>	MCS/PCS Hold from Command Inactive <sup>(a)</sup>	t <sub>CLCH</sub> -2		t <sub>CLCH</sub> -2		ns
18	t <sub>CHCSX</sub>	MCS/PCS Inactive Delay	0	25	0	20	ns
19	t <sub>DXDL</sub>	DEN Inactive to DT/R Low <sup>(a)</sup>	0		0		ns
20	t <sub>CVCTV</sub>	Control Active Delay 1 <sup>(b)</sup>	0	15	0	15	ns
21	t <sub>CVDEX</sub>	DS Inactive Delay	0	25	0	20	ns
22	t <sub>CHCTV</sub>	Control Active Delay 2	0	25	0	20	ns
23	t <sub>LHAV</sub>	ALE High to Address Valid	20		15		ns
99	t <sub>PLAL</sub>	PCS Active to ALE Inactive	15	28	15	24	ns
<b>Write Cycle Timing Responses</b>							
30	t <sub>CLDOX</sub>	Data Hold Time	0		0		ns
31	t <sub>CVCTX</sub>	Control Inactive Delay <sup>(b)</sup>	0	25	0	20	ns
32	t <sub>WLWH</sub>	WR Pulse Width	2t <sub>CLCL</sub> -10=90		2t <sub>CLCL</sub> -10=70		ns
33	t <sub>WHLH</sub>	WR Inactive to ALE High <sup>(a)</sup>	t <sub>CLCH</sub> -2		t <sub>CLCH</sub> -2		ns
34	t <sub>WHDX</sub>	Data Hold after WR <sup>(a)</sup>	t <sub>CLCL</sub> -10=40		t <sub>CLCL</sub> -10=30		ns
35	t <sub>WHDEX</sub>	WR Inactive to DEN Inactive <sup>(a)</sup>	t <sub>CLCH</sub> -3		t <sub>CLCH</sub> -3		ns
41	t <sub>DSHLH</sub>	DS Inactive to ALE Active	t <sub>CLCH</sub> -2=21		t <sub>CLCH</sub> -2=16		ns
65	t <sub>AVWL</sub>	A Address Valid to WR Low	t <sub>CLCL</sub> +t <sub>CHCL</sub> -3		t <sub>CLCL</sub> +t <sub>CHCL</sub> -3		ns
67	t <sub>CHCSV</sub>	CLKOUTA High to LCS/UCS Valid	0	25	0	20	ns
68	t <sub>CHAV</sub>	CLKOUTA High to A Address Valid	0	25	0	20	ns
87	t <sub>AVBL</sub>	A Address Valid to WHB, WLB Low	t <sub>CHCL</sub> -3	25	t <sub>CHCL</sub> -3	20	ns
98	t <sub>DSHDIW</sub>	DS High to Data Invalid—Write	35		30		ns

**Notes:**

All timing parameters are measured at 1.5 V with 50 pF loading on CLKOUTA, unless otherwise noted. All output test conditions are with C<sub>L</sub>=50 pF. For switching tests, V<sub>IL</sub>=0.45 V and V<sub>IH</sub>=2.4 V, except at X1 where V<sub>IH</sub>=V<sub>CC</sub>-0.5 V.

a Testing is performed with equal loading on referenced pins.

b This parameter applies to the DEN, DS, INTA1-INTA0, WR, WHB, and WLB signals.

## SWITCHING CHARACTERISTICS over COMMERCIAL operating ranges

## Write Cycle (33 MHz and 40 MHz)

Parameter			Preliminary				Unit
			33 MHz		40 MHz		
No.	Symbol	Description	Min	Max	Min	Max	Unit
<b>General Timing Responses</b>							
3	t <sub>CHSV</sub>	Status Active Delay	0	15	0	12	ns
4	t <sub>CLSH</sub>	Status Inactive Delay	0	15	0	12	ns
5	t <sub>CLAV</sub>	AD Address Valid Delay and BHE	0	15	0	12	ns
6	t <sub>CLAX</sub>	Address Hold	0		0		ns
7	t <sub>CLDV</sub>	Data Valid Delay	0	15	0	12	ns
8	t <sub>CHDX</sub>	Status Hold Time	0		0		ns
9	t <sub>CHLH</sub>	ALE Active Delay		15		12	ns
10	t <sub>LHLL</sub>	ALE Width	t <sub>CLCL</sub> -10=20		t <sub>CLCL</sub> -5=20		ns
11	t <sub>CHLL</sub>	ALE Inactive Delay		15		12	ns
12	t <sub>AVLL</sub>	AD Address Valid to ALE Low <sup>(a)</sup>	t <sub>CLCH</sub> -2		t <sub>CLCH</sub> -2		ns
13	t <sub>LLAX</sub>	AD Address Hold from ALE Inactive <sup>(a)</sup>	t <sub>CHCL</sub> -2		t <sub>CHCL</sub> -2		ns
14	t <sub>AVCH</sub>	AD Address Valid to Clock High	0		0		ns
16	t <sub>CLCSV</sub>	MCS/PCS Active Delay	0	15	0	12	ns
17	t <sub>CXCSX</sub>	MCS/PCS Hold from Command Inactive <sup>(a)</sup>	t <sub>CLCH</sub> -2		t <sub>CLCH</sub> -2		ns
18	t <sub>CHCSX</sub>	MCS/PCS Inactive Delay	0	15	0	12	ns
19	t <sub>DXDL</sub>	DEN Inactive to DT/R Low <sup>(a)</sup>	0		0		ns
20	t <sub>CVCTV</sub>	Control Active Delay 1 <sup>(b)</sup>	0	15	0	12	ns
21	t <sub>CVDEX</sub>	DS Inactive Delay	0	15	0	12	ns
22	t <sub>CHCTV</sub>	Control Active Delay 2	0	15	0	12	ns
23	t <sub>LHAV</sub>	ALE High to Address Valid	10		7.5		ns
99	t <sub>PLAL</sub>	PCS Active to ALE Inactive	12	20	10	18	ns
<b>Write Cycle Timing Responses</b>							
30	t <sub>CLDOX</sub>	Data Hold Time	0		0		ns
31	t <sub>CVCTX</sub>	Control Inactive Delay <sup>(b)</sup>	0	15	0	12	ns
32	t <sub>WLWH</sub>	WR Pulse Width	2t <sub>CLCL</sub> -10=50		2t <sub>CLCL</sub> -10=40		ns
33	t <sub>WHLH</sub>	WR Inactive to ALE High <sup>(a)</sup>	t <sub>CLCH</sub> -2		t <sub>CLCH</sub> -2		ns
34	t <sub>WHDX</sub>	Data Hold after WR <sup>(a)</sup>	t <sub>CLCL</sub> -10=20		t <sub>CLCL</sub> -10=15		ns
35	t <sub>WHDEX</sub>	WR Inactive to DEN Inactive <sup>(a)</sup>	t <sub>CLCH</sub> -3		t <sub>CLCH</sub> -3		ns
41	t <sub>DSHLH</sub>	DS Inactive to ALE Active	t <sub>CLCH</sub> -2=11.5		t <sub>CLCH</sub> -2=9.25		ns
65	t <sub>AVWL</sub>	A Address Valid to WR Low	t <sub>CLCL</sub> +t <sub>CHCL</sub> -3		t <sub>CLCL</sub> +t <sub>CHCL</sub> -1.25		ns
67	t <sub>CHCSV</sub>	CLKOUTA High to LCS/UCS Valid	0	15	0	10	ns
68	t <sub>CHAV</sub>	CLKOUTA High to A Address Valid	0	15	0	10	ns
87	t <sub>AVBL</sub>	A Address Valid to WHB, WLB Low	t <sub>CHCL</sub> -3	15	t <sub>CHCL</sub> -1.25	12	ns
98	t <sub>DSHDW</sub>	DS High to Data Invalid—Write	20		15		ns

**Notes:**

All timing parameters are measured at 1.5 V with 50 pF loading on CLKOUTA, unless otherwise noted. All output test conditions are with C<sub>L</sub>=50 pF. For switching tests, V<sub>IL</sub>=0.45 V and V<sub>IH</sub>=2.4 V, except at X1 where V<sub>IH</sub>=V<sub>CC</sub>-0.5 V.

a Testing is performed with equal loading on referenced pins.

b This parameter applies to the DEN, DS, INTA1–INTA0, WR, WHB, and WLB signals.

### WRITE CYCLE WAVEFORMS

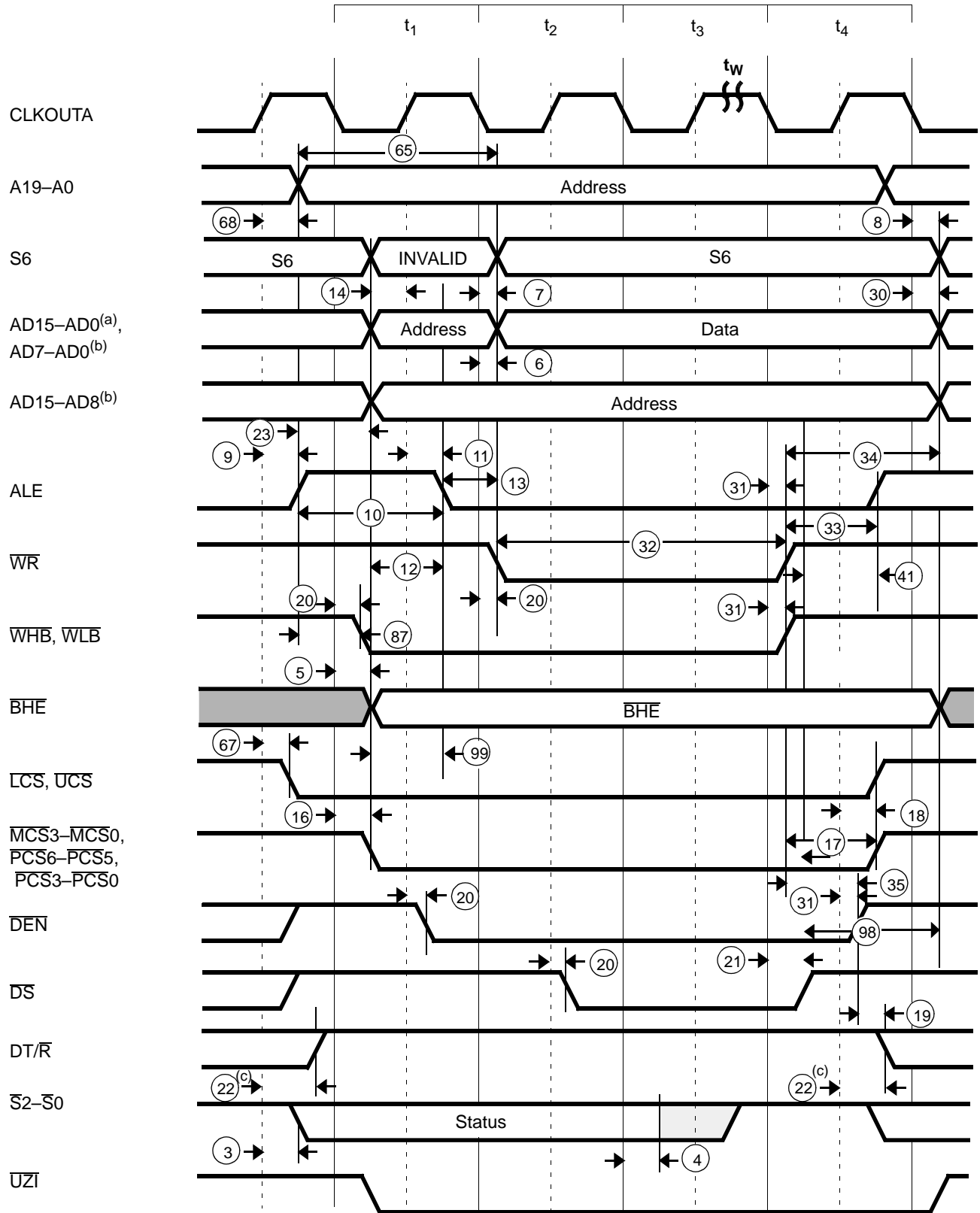

**Notes:**

- a Am186ED/EDLV microcontrollers in 16-bit mode
- b Am186ED/EDLV microcontrollers in 8-bit mode
- c Changes in  $t$  phase preceding next bus cycle if followed by read, INTA, or halt

## SWITCHING CHARACTERISTICS over COMMERCIAL and INDUSTRIAL operating ranges DRAM

Parameter			Preliminary								Unit
			20 MHz		25 MHz		33 MHz		40 MHz		
No.	Symbol	Description	Min	Max	Min	Max	Min	Max	Min	Max	
<b>General Timing Responses</b>											
101	$t_{\text{CHCAV}}$	CLKOUTA Low to Column Address Valid	0	25	0	20	0	15	0	12	ns
102	$t_{\text{CLRA}}$	CLKOUTA Low to $\overline{\text{RAS}}$ Active	3	25	3	20	3	15	3	12	ns
103	$t_{\text{CHRX}}$	CLKOUTA High to $\overline{\text{RAS}}$ Inactive	3	25	3	20	3	15	3	12	ns
104	$t_{\text{CHCA}}$	CLKOUTA High to $\overline{\text{CAS}}$ Active	3	25	3	20	3	15	3	12	ns
105	$t_{\text{CLCX}}$	CLKOUTA Low to $\overline{\text{CAS}}$ Inactive	3	25	3	20	3	15	3	12	ns
106	$t_{\text{CHRA}}$	CLKOUTA High to $\overline{\text{RAS}}$ Active	3	25	3	20	3	15	3	12	ns
107	$t_{\text{CLR X}}$	CLKOUTA Low to $\overline{\text{RAS}}$ Inactive	3	25	3	20	3	15	3	12	ns
108	$t_{\text{RP0W}}$	$\overline{\text{RAS}}$ Inactive Pulse Width with 0 Wait States	60	—	50	—	40	—	30	—	ns
109	$t_{\text{RP1W}}$	$\overline{\text{RAS}}$ Inactive Pulse Width with 1 or More Wait States	70	—	60	—	50	—	40	—	ns
110	$t_{\text{RD0W}}$	$\overline{\text{RAS}}$ To Column Address Delay Time with 0 Wait States	25	—	20	—	15	—	15	—	ns
111	$t_{\text{RD1W}}$	$\overline{\text{RAS}}$ to Column Address Delay Time with 1 or More Wait States	30	—	25	—	20	—	15	—	ns

As guaranteed by design, the following table shows the minimum time for  $\overline{\text{RAS}}$  assertion to  $\overline{\text{RAS}}$  assertion. These minimums correlate to DRAM spec  $t_{\text{RC}}$ .

		Wait States			
		0	1	2	3
Frequency	40 MHz	90	110	130	150
	33 MHz	110	130	150	170
	25 MHz	130	150	170	190
	20 MHz	150	170	190	210

### DRAM Read Cycle Timing with No-Wait States

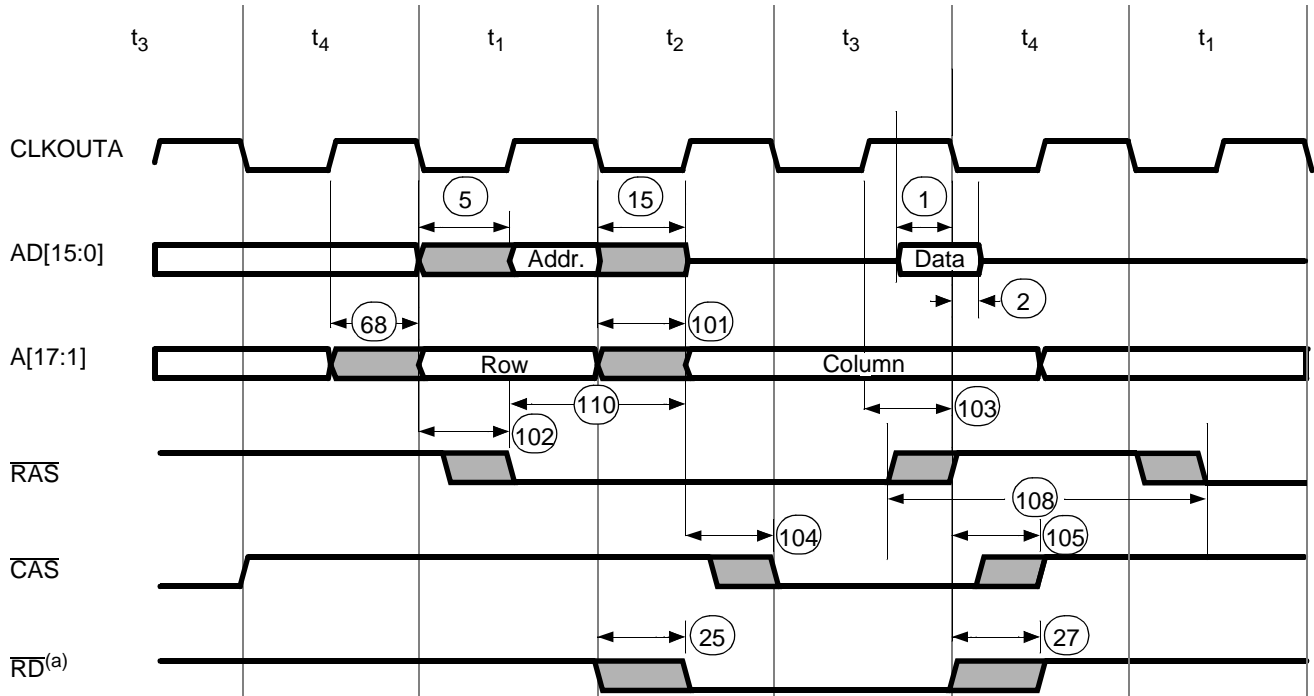

**Note:**

a The  $\overline{RD}$  output connects to the DRAM output enable ( $\overline{OE}$ ) pin for read operations.

### DRAM Read Cycle Timing with Wait State(s)

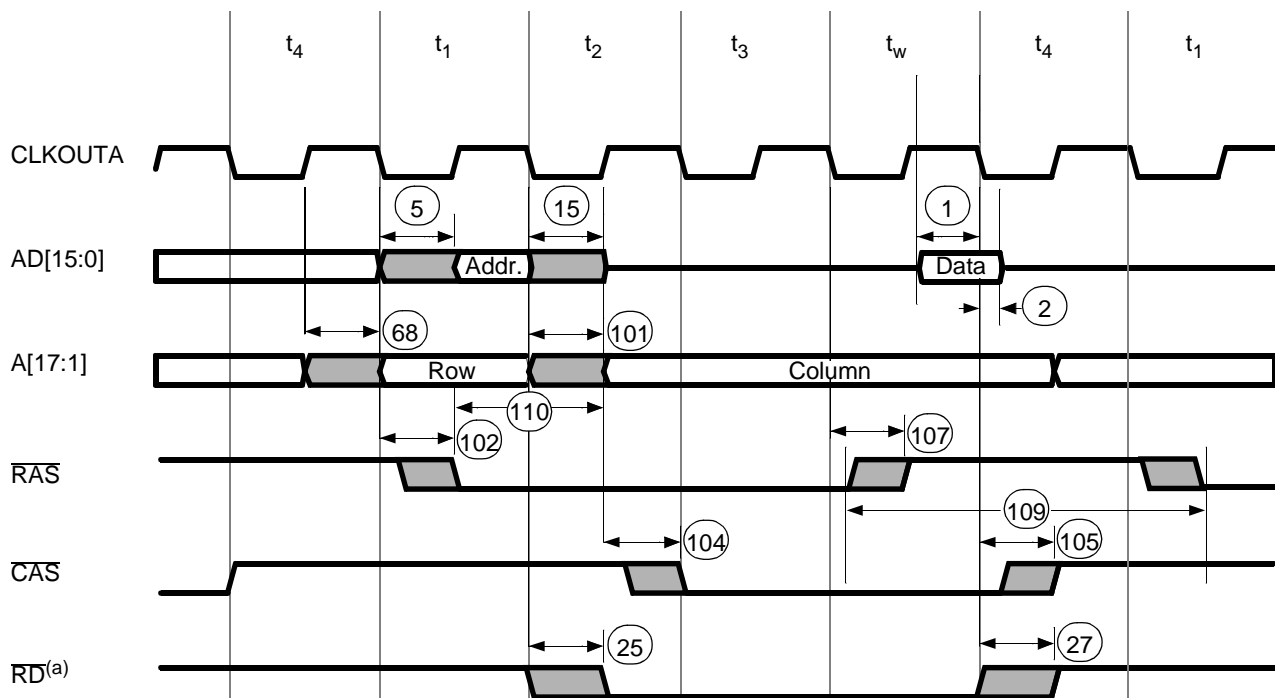

**Note:**

a The  $\overline{RD}$  output connects to the DRAM output enable ( $\overline{OE}$ ) pin for read operations.

DRAM Write Cycle Timing with No-Wait States

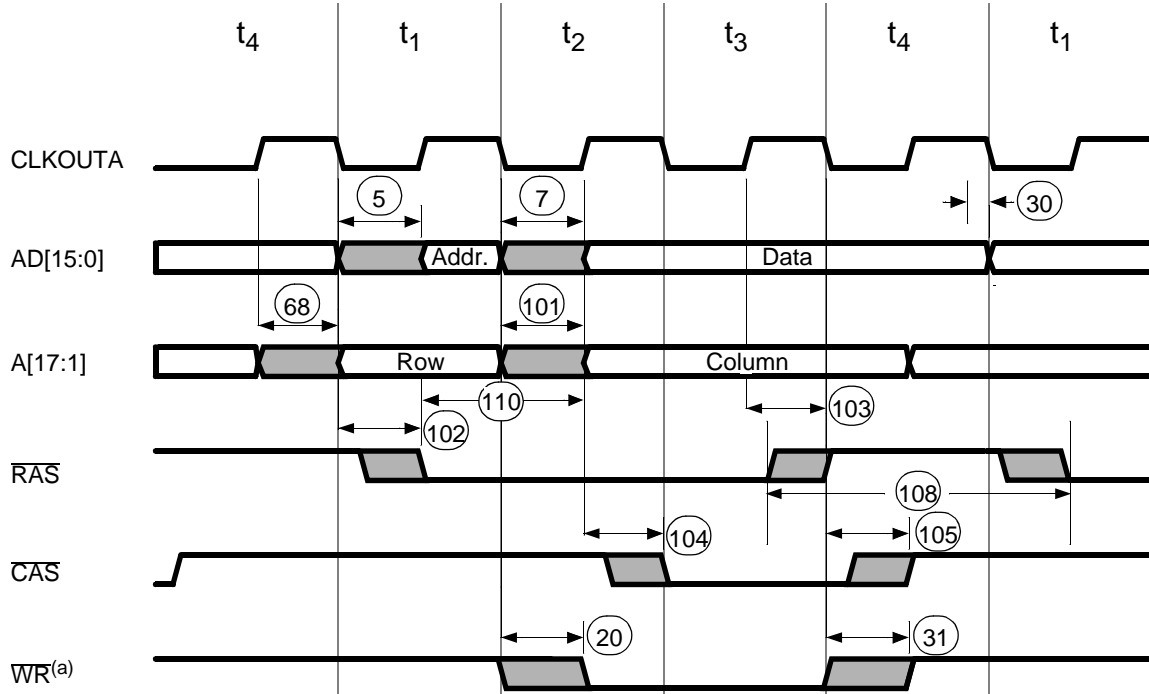

Note:

a Write operations use the  $\overline{WR}$  output connected to the DRAM write enable ( $\overline{WE}$ ) pin.

DRAM Write Cycle Timing With Wait State(s)

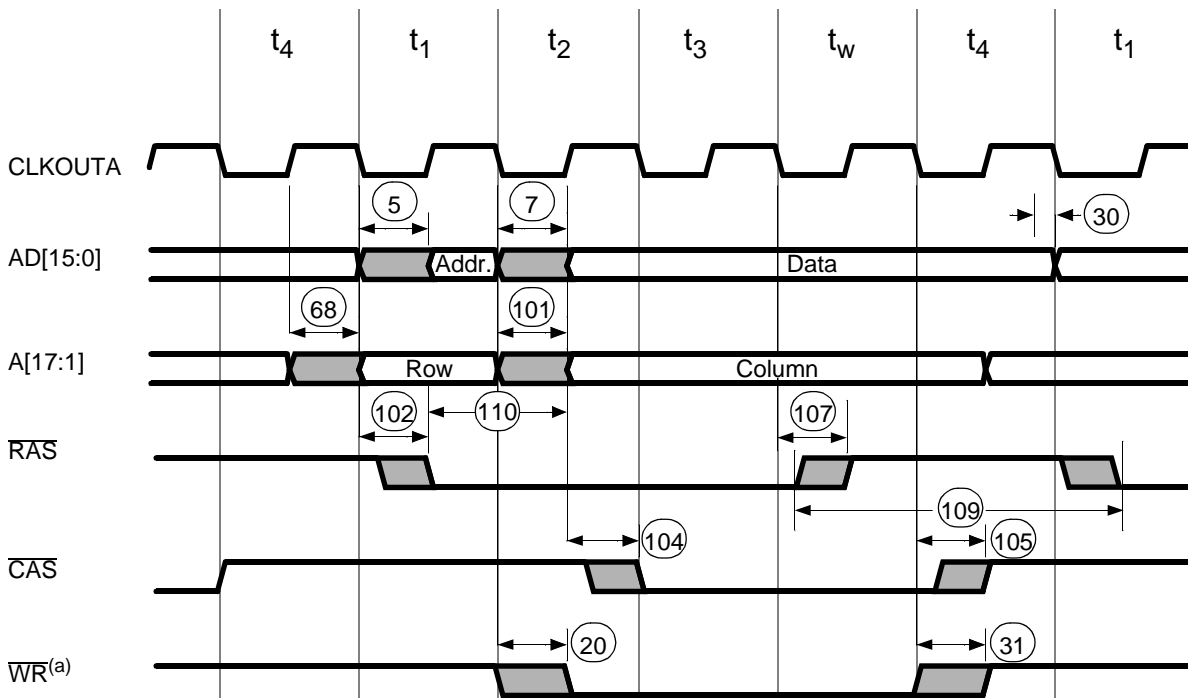

Note:

a Write operations use the  $\overline{WR}$  output connected to the DRAM write enable ( $\overline{WE}$ ) pin.



### DRAM $\overline{\text{CAS}}$ -before- $\overline{\text{RAS}}$ Cycle Timing

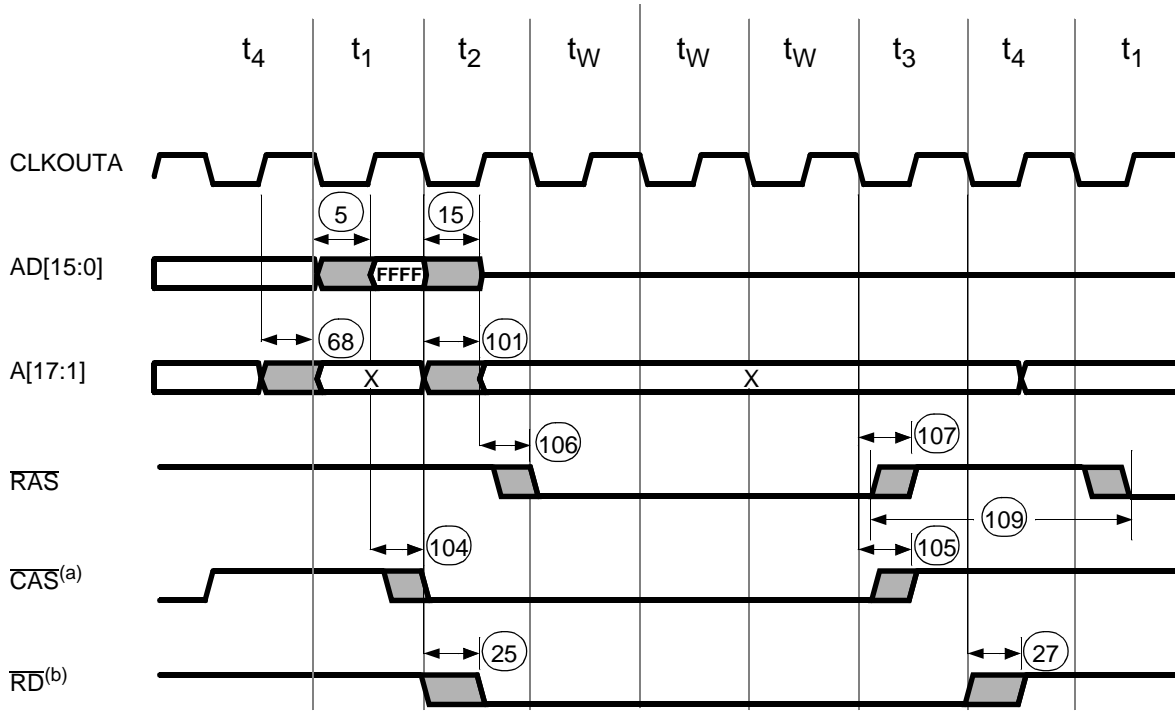

**Notes:**

- a  $\overline{\text{CAS}}$  before  $\overline{\text{RAS}}$  cycle timing is always 7 clocks, independent of wait state timing.
- b The  $\overline{\text{RD}}$  output connects to the DRAM output enable ( $\overline{\text{OE}}$ ) pin for read operations.

**SWITCHING CHARACTERISTICS over COMMERCIAL and INDUSTRIAL operating ranges  
Interrupt Acknowledge Cycle (20 MHz and 25 MHz)**

Parameter			Preliminary				Unit
			20 MHz		25 MHz		
No.	Symbol	Description	Min	Max	Min	Max	
<b>General Timing Requirements</b>							
1	$t_{DVCL}$	Data in Setup	10		10		ns
2	$t_{CLDX}$	Data in Hold	3		3		ns
<b>General Timing Responses</b>							
3	$t_{CHSV}$	Status Active Delay	0	25	0	20	ns
4	$t_{CLSH}$	Status Inactive Delay	0	25	0	20	ns
7	$t_{CLDV}$	Data Valid Delay	0	25	0	20	ns
8	$t_{CHDX}$	Status Hold Time	0		0		ns
9	$t_{CHLH}$	ALE Active Delay		25		20	ns
10	$t_{LHLL}$	ALE Width	$t_{CLCL}-10=40$		$t_{CLCL}-10=30$		ns
11	$t_{CHLL}$	ALE Inactive Delay		25		20	ns
12	$t_{AVLL}$	AD Address Invalid to ALE Low <sup>(a)</sup>	$t_{CLCH}-2$		$t_{CLCH}-2$		ns
15	$t_{CLAZ}$	AD Address Float Delay	$t_{CLAX}=0$	25	$t_{CLAX}=0$	20	ns
19	$t_{DXDL}$	$\overline{DEN}$ Inactive to $DT/\overline{R}$ Low <sup>(a)</sup>	0		0		ns
20	$t_{CVCTV}$	Control Active Delay 1 <sup>(b)</sup>	0	25	0	20	ns
21	$t_{CVDEX}$	$\overline{DEN}$ Inactive Delay	0	25	0	20	ns
22	$t_{CHCTV}$	Control Active Delay 2 <sup>(c)</sup>	0	25	0	20	ns
23	$t_{LHAV}$	ALE High to Address Valid	20		15		ns
31	$t_{CVCTX}$	Control Inactive Delay <sup>(b)</sup>	0	25	0	20	ns
68	$t_{CHAV}$	CLKOUTA High to A Address Valid	0	25	0	20	ns

**Notes:**

All timing parameters are measured at 1.5 V with 50 pF loading on CLKOUTA, unless otherwise noted. All output test conditions are with  $C_L=50$  pF. For switching tests,  $V_{IL}=0.45$  V and  $V_{IH}=2.4$  V, except at X1 where  $V_{IH}=V_{CC}-0.5$  V.

a Testing is performed with equal loading on referenced pins.

b This parameter applies to the  $\overline{INTA1}$ – $\overline{INTA0}$  signals.

c This parameter applies to the  $\overline{DEN}$  and  $DT/\overline{R}$  signals.

## SWITCHING CHARACTERISTICS over COMMERCIAL operating ranges

### Interrupt Acknowledge Cycle (33 MHz and 40 MHz)

Parameter			Preliminary				Unit
			33 MHz		40 MHz		
No.	Symbol	Description	Min	Max	Min	Max	
<b>General Timing Requirements</b>							
1	t <sub>DVCL</sub>	Data in Setup	8		5		ns
2	t <sub>CLDX</sub>	Data in Hold	3		2		ns
<b>General Timing Responses</b>							
3	t <sub>CHSV</sub>	Status Active Delay	0	15	0	12	ns
4	t <sub>CLSH</sub>	Status Inactive Delay	0	15	0	12	ns
7	t <sub>CLDV</sub>	Data Valid Delay	0	15	0	12	ns
8	t <sub>CHDX</sub>	Status Hold Time	0		0		ns
9	t <sub>CHLH</sub>	ALE Active Delay		15		12	ns
10	t <sub>LHLL</sub>	ALE Width	t <sub>CLCL</sub> -10=20		t <sub>CLCL</sub> -5=20		ns
11	t <sub>CHLL</sub>	ALE Inactive Delay		15		12	ns
12	t <sub>AVLL</sub>	AD Address Invalid to ALE Low <sup>(a)</sup>	t <sub>CLCH</sub>		t <sub>CLCH</sub>		ns
15	t <sub>CLAZ</sub>	AD Address Float Delay	t <sub>CLAX</sub> =0	15	t <sub>CLAX</sub> =0	12	ns
19	t <sub>DXDL</sub>	$\overline{DEN}$ Inactive to DT/ $\overline{R}$ Low <sup>(a)</sup>	0		0		ns
20	t <sub>CVCTV</sub>	Control Active Delay 1 <sup>(b)</sup>	0	15	0	12	ns
21	t <sub>CVDEX</sub>	$\overline{DEN}$ Inactive Delay	0	15	0	12	ns
22	t <sub>CHCTV</sub>	Control Active Delay 2 <sup>(c)</sup>	0	15	0	12	ns
23	t <sub>LHAV</sub>	ALE High to Address Valid	10		7.5		ns
31	t <sub>CVCTX</sub>	Control Inactive Delay <sup>(b)</sup>	0	15	0	12	ns
68	t <sub>CHAV</sub>	CLKOUTA High to A Address Valid	0	15	0	10	ns

**Notes:**

All timing parameters are measured at 1.5 V with 50 pF loading on CLKOUTA, unless otherwise noted. All output test conditions are with C<sub>L</sub>=50 pF. For switching tests, V<sub>IL</sub>=0.45 V and V<sub>IH</sub>=2.4 V, except at X1 where V<sub>IH</sub>=V<sub>CC</sub>-0.5 V.

a Testing is performed with equal loading on referenced pins.

b This parameter applies to the  $\overline{INTA1}$ – $\overline{INTA0}$  signals.

c This parameter applies to the  $\overline{DEN}$  and DT/ $\overline{R}$  signals.

INTERRUPT ACKNOWLEDGE CYCLE WAVEFORMS

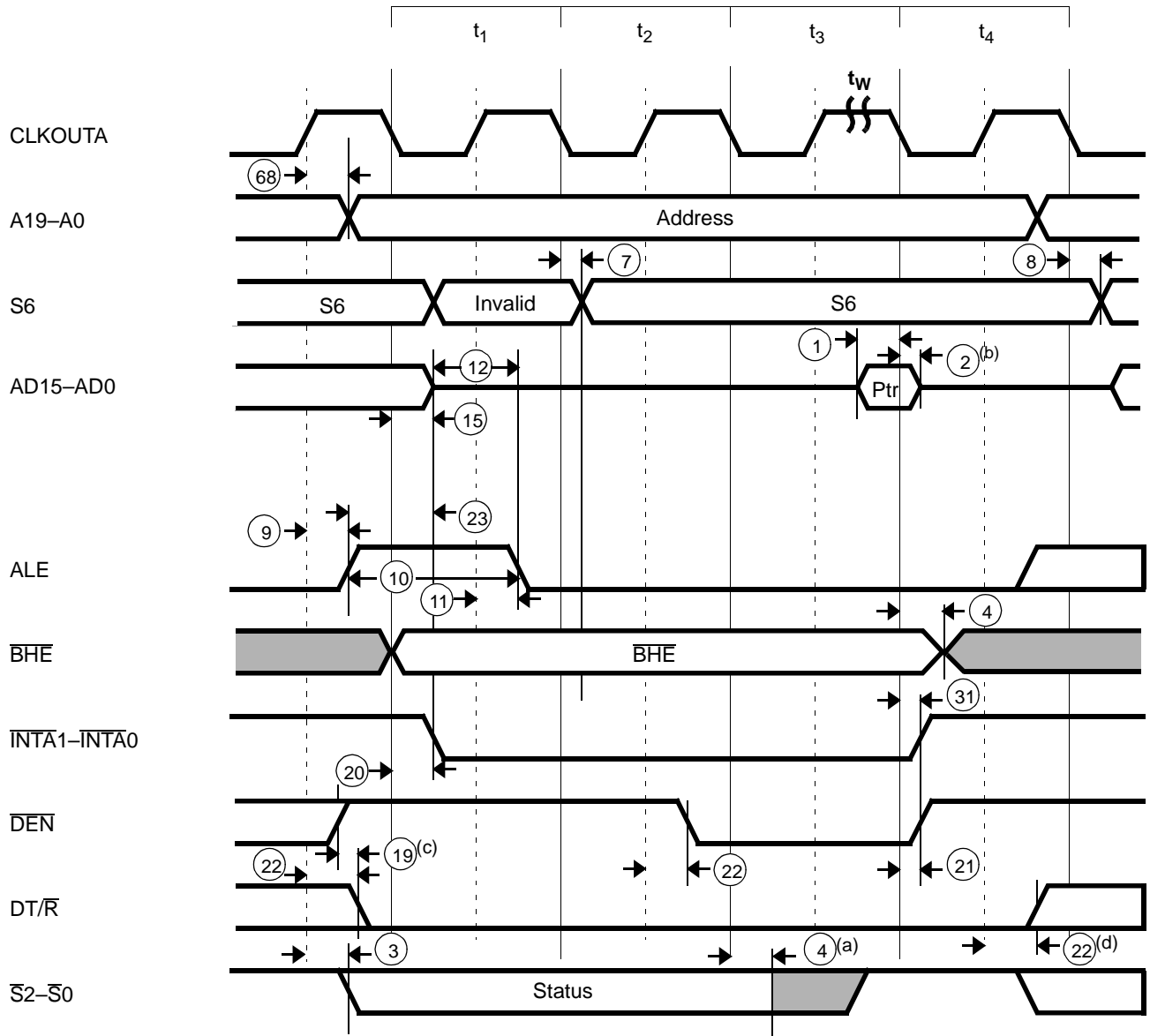

Notes:

- a The status bits become inactive in the state preceding  $t_4$ .
- b The data hold time lasts only until the interrupt acknowledge signal deasserts, even if the interrupt acknowledge transition occurs prior to  $t_{CLDX}$  (min).
- c This parameter applies for an interrupt acknowledge cycle that follows a write cycle.
- d If followed by a write cycle, this change occurs in the state preceding that write cycle.

## SWITCHING CHARACTERISTICS over COMMERCIAL and INDUSTRIAL operating ranges Software Halt Cycle (20 MHz and 25 MHz)

Parameter			Preliminary				Unit
			20 MHz		25 MHz		
No.	Symbol	Description	Min	Max	Min	Max	
<b>General Timing Responses</b>							
3	t <sub>CHSV</sub>	Status Active Delay	0	25	0	20	ns
4	t <sub>CLSH</sub>	Status Inactive Delay	0	25	0	20	ns
5	t <sub>CLAV</sub>	AD Address Invalid Delay and BHE	0	25	0	20	ns
9	t <sub>CHLH</sub>	ALE Active Delay		25		20	ns
10	t <sub>LHLL</sub>	ALE Width	t <sub>CLCL</sub> -10=40		t <sub>CLCL</sub> -10=30		ns
11	t <sub>CHLL</sub>	ALE Inactive Delay		25		20	ns
19	t <sub>DXDL</sub>	$\overline{DEN}$ Inactive to DT/ $\overline{R}$ Low <sup>(a)</sup>	0		0		ns
22	t <sub>CHCTV</sub>	Control Active Delay 2 <sup>(b)</sup>	0	25	0	20	ns
68	t <sub>CHAV</sub>	CLKOUTA High to A Address Invalid	0	25	0	20	ns

**Notes:**

All timing parameters are measured at 1.5 V with 50 pF loading on CLKOUTA, unless otherwise noted. All output test conditions are with C<sub>L</sub>=50 pF. For switching tests, V<sub>IL</sub>=0.45 V and V<sub>IH</sub>=2.4 V, except at X1 where V<sub>IH</sub>=V<sub>CC</sub>-0.5 V.

a Testing is performed with equal loading on referenced pins.

b This parameter applies to the  $\overline{DEN}$  signal.

## SWITCHING CHARACTERISTICS over COMMERCIAL operating ranges Software Halt Cycle (33 MHz and 40 MHz)

Parameter			Preliminary				Unit
			33 MHz		40 MHz		
No.	Symbol	Description	Min	Max	Min	Max	
<b>General Timing Responses</b>							
3	t <sub>CHSV</sub>	Status Active Delay	0	15	0	12	ns
4	t <sub>CLSH</sub>	Status Inactive Delay	0	15	0	12	ns
5	t <sub>CLAV</sub>	AD Address Invalid Delay and BHE	0	15	0	12	ns
9	t <sub>CHLH</sub>	ALE Active Delay		15		12	ns
10	t <sub>LHLL</sub>	ALE Width	t <sub>CLCL</sub> -10=20		t <sub>CLCL</sub> -5=20		ns
11	t <sub>CHLL</sub>	ALE Inactive Delay		15		12	ns
19	t <sub>DXDL</sub>	$\overline{DEN}$ Inactive to DT/ $\overline{R}$ Low <sup>(a)</sup>	0		0		ns
22	t <sub>CHCTV</sub>	Control Active Delay 2 <sup>(b)</sup>	0	15	0	12	ns
68	t <sub>CHAV</sub>	CLKOUTA High to A Address Invalid	0	15	0	10	ns

**Notes:**

All timing parameters are measured at 1.5 V with 50 pF loading on CLKOUTA, unless otherwise noted. All output test conditions are with C<sub>L</sub>=50 pF. For switching tests, V<sub>IL</sub>=0.45 V and V<sub>IH</sub>=2.4 V, except at X1 where V<sub>IH</sub>=V<sub>CC</sub>-0.5 V.

a Testing is performed with equal loading on referenced pins.

b This parameter applies to the  $\overline{DEN}$  signal.

SOFTWARE HALT CYCLE WAVEFORMS

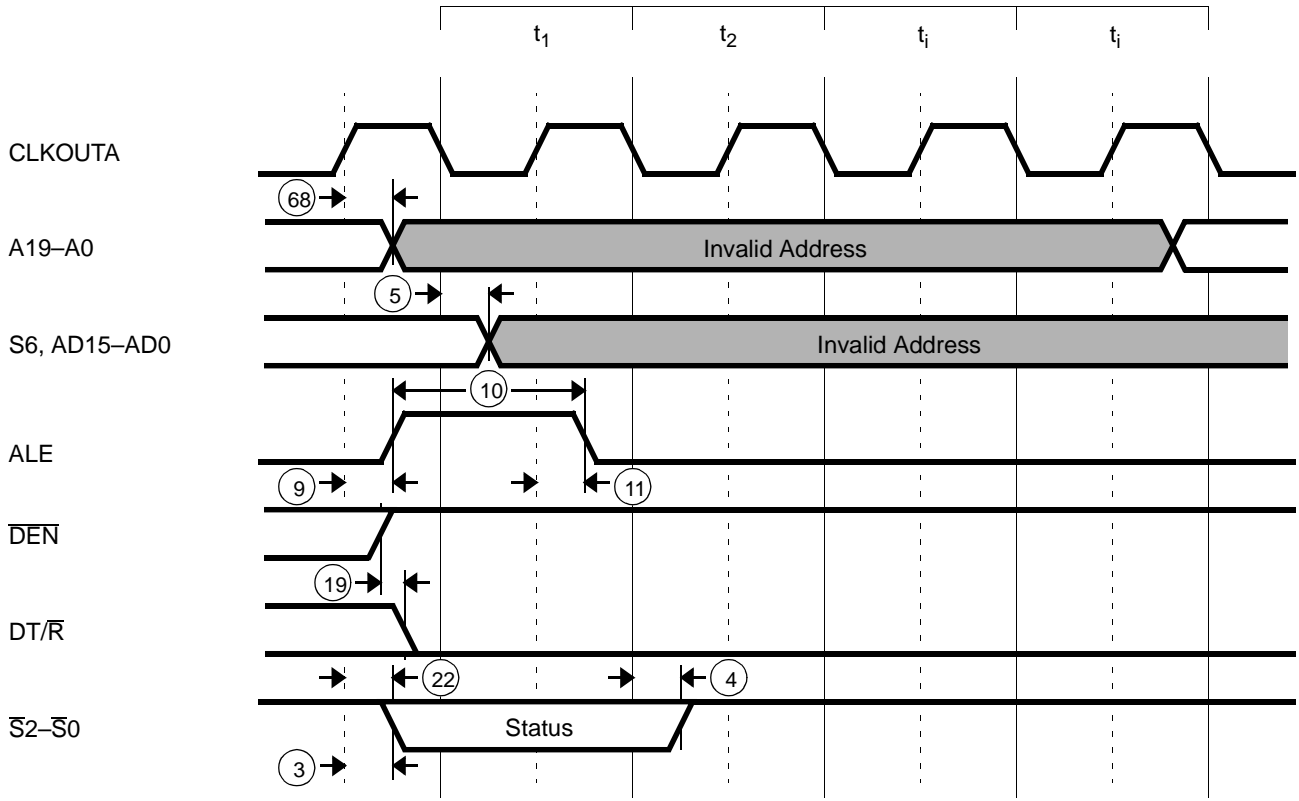



## SWITCHING CHARACTERISTICS over COMMERCIAL and INDUSTRIAL operating ranges Clock (20 MHz and 25 MHz)

Parameter			Preliminary				Unit
			20 MHz		25 MHz		
No.	Symbol	Description	Min	Max	Min	Max	Unit
<b>CLKIN Requirements</b>							
36	t <sub>CKIN</sub>	X1 Period <sup>(a)</sup>	50	60	40	60	ns
37	t <sub>CLCK</sub>	X1 Low Time (1.5 V) <sup>(a)</sup>	15		15		ns
38	t <sub>CHCK</sub>	X1 High Time (1.5 V) <sup>(a)</sup>	15		15		ns
39	t <sub>CKHL</sub>	X1 Fall Time (3.5 to 1.0 V) <sup>(a)</sup>		5		5	ns
40	t <sub>CKLH</sub>	X1 Rise Time (1.0 to 3.5 V) <sup>(a)</sup>		5		5	ns
<b>CLKOUT Timing</b>							
42	t <sub>CLCL</sub>	CLKOUTA Period	50		40		ns
43	t <sub>CLCH</sub>	CLKOUTA Low Time (C <sub>L</sub> =50 pF)	0.5t <sub>CLCL</sub> -2=23		0.5t <sub>CLCL</sub> -2=18		ns
44	t <sub>CHCL</sub>	CLKOUTA High Time (C <sub>L</sub> =50 pF)	0.5t <sub>CLCL</sub> -2=23		0.5t <sub>CLCL</sub> -2=18		ns
45	t <sub>CH1CH2</sub>	CLKOUTA Rise Time (1.0 to 3.5 V)		3		3	ns
46	t <sub>CL2CL1</sub>	CLKOUTA Fall Time (3.5 to 1.0 V)		3		3	ns
61	t <sub>LOCK</sub>	Maximum PLL Lock Time		1		1	ms
69	t <sub>CICOA</sub>	X1 to CLKOUTA Skew		15		15	ns
70	t <sub>CICOB</sub>	X1 to CLKOUTB Skew		25		25	ns

**Notes:**

All timing parameters are measured at 1.5 V with 50 pF loading on CLKOUTA, unless otherwise noted. All output test conditions are with C<sub>L</sub>=50 pF. For switching tests, V<sub>IL</sub>=0.45 V and V<sub>IH</sub>=2.4 V, except at X1 where V<sub>IH</sub>=V<sub>CC</sub>-0.5 V.

a The specifications for CLKIN are applicable to the normal PLL and CLKDIV2 modes.

The PLL should be used for operations from 16.667 MHz to 40 MHz. For operations below 16.667 MHz, the CLKDIV2 mode should be used.

Because the CLKDIV2 input frequency is two times the system frequency, the specifications for twice the frequency should be used for CLKDIV2 mode. For example, use the 20 MHz CLKIN specifications for 10 MHz operation.

## SWITCHING CHARACTERISTICS over Commercial operating ranges

## Clock (33 MHz and 40 MHz)

Parameter			Preliminary				Unit
			33 MHz		40 MHz		
No.	Symbol	Description	Min	Max	Min	Max	
<b>CLKIN Requirements</b>							
36	$t_{CKIN}$	X1 Period <sup>(a)</sup>	30	60	25	60	ns
37	$t_{CLK}$	X1 Low Time (1.5 V) <sup>(a)</sup>	10		7.5		ns
38	$t_{CHCK}$	X1 High Time (1.5 V) <sup>(a)</sup>	10		7.5		ns
39	$t_{CKHL}$	X1 Fall Time (3.5 to 1.0 V) <sup>(a)</sup>		5		5	ns
40	$t_{CKLH}$	X1 Rise Time (1.0 to 3.5 V) <sup>(a)</sup>		5		5	ns
<b>CLKOUT Timing</b>							
42	$t_{CLCL}$	CLKOUTA Period	30		25		ns
43	$t_{CLCH}$	CLKOUTA Low Time ( $C_L=50$ pF)	$0.5t_{CLCL}-1.5=13.5$		$0.5t_{CLCL}-1.25=11.25$		ns
44	$t_{CHCL}$	CLKOUTA High Time ( $C_L=50$ pF)	$0.5t_{CLCL}-1.5=13.5$		$0.5t_{CLCL}-1.25=11.25$		ns
45	$t_{CH1CH2}$	CLKOUTA Rise Time (1.0 to 3.5 V)		3		3	ns
46	$t_{CL2CL1}$	CLKOUTA Fall Time (3.5 to 1.0 V)		3		3	ns
61	$t_{LOCK}$	Maximum PLL Lock Time		1		1	ms
69	$t_{CICOA}$	X1 to CLKOUTA Skew		15		15	ns
70	$t_{CICOB}$	X1 to CLKOUTB Skew		25		25	ns

**Notes:**

All timing parameters are measured at 1.5 V with 50 pF loading on CLKOUTA, unless otherwise noted. All output test conditions are with  $C_L=50$  pF. For switching tests,  $V_{IL}=0.45$  V and  $V_{IH}=2.4$  V, except at X1 where  $V_{IH}=V_{CC}-0.5$  V.

a The specifications for CLKIN are applicable to the normal PLL and CLKDIV2 modes.

The PLL should be used for operations from 16.667 MHz to 40 MHz. For operations below 16.667 MHz, the CLKDIV2 mode should be used.

Because the CLKDIV2 input frequency is two times the system frequency, the specifications for twice the frequency should be used for CLKDIV2 mode. For example, use the 20 MHz CLKIN specifications for 10 MHz operation.

## CLOCK WAVEFORMS

### Clock Waveforms—Active Mode

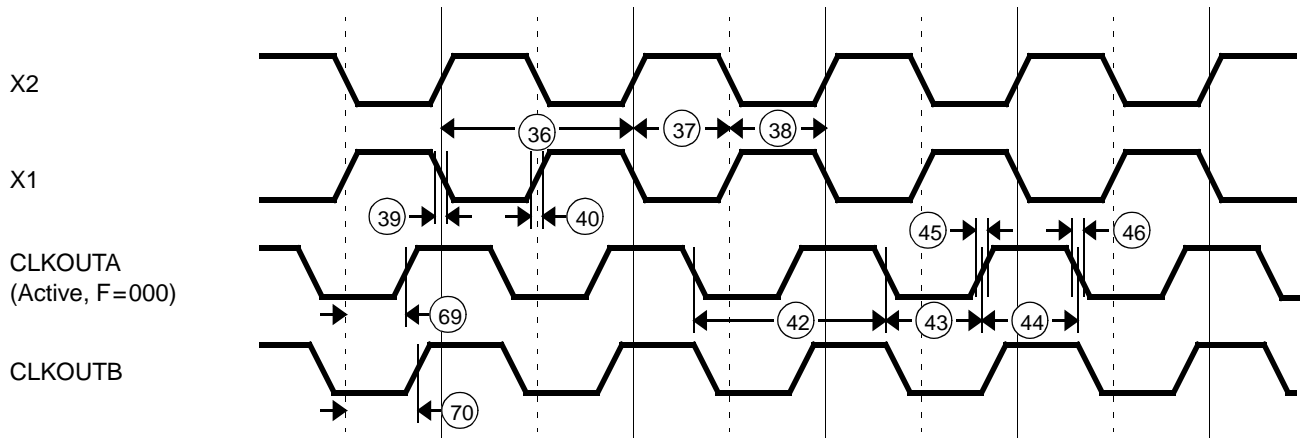

### Clock Waveforms—Power-Save Mode

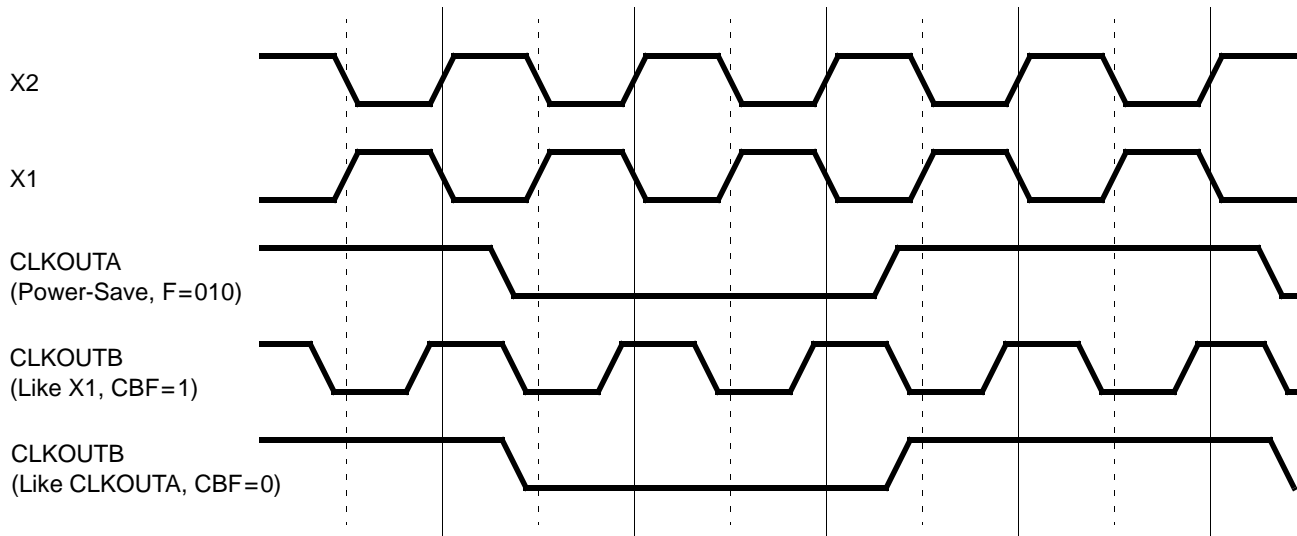

## SWITCHING CHARACTERISTICS over COMMERCIAL and INDUSTRIAL operating ranges Ready and Peripheral (20 MHz and 25 MHz)

Parameter			Preliminary		Preliminary		Unit
			20 MHz		25 MHz		
No.	Symbol	Description	Min	Max	Min	Max	
<b>Ready and Peripheral Timing Requirements</b>							
47	$t_{\text{SRVCL}}$	SRDY Transition Setup Time <sup>(a)</sup>	10		10		ns
48	$t_{\text{CLSRV}}$	SRDY Transition Hold Time <sup>(a)</sup>	3		3		ns
49	$t_{\text{ARVCH}}$	ARDY Resolution Transition Setup Time <sup>(b)</sup>	10		10		ns
50	$t_{\text{CLARX}}$	ARDY Active Hold Time <sup>(a)</sup>	4		4		ns
51	$t_{\text{ARVCHL}}$	ARDY Inactive Holding Time	6		6		ns
52	$t_{\text{ARVCL}}$	ARDY Setup Time <sup>(a)</sup>	15		15		ns
53	$t_{\text{INVCH}}$	Peripheral Setup Time <sup>(b)</sup>	10		10		ns
54	$t_{\text{INVCL}}$	DRQ Setup Time <sup>(b)</sup>	10		10		ns
<b>Peripheral Timing Responses</b>							
55	$t_{\text{CLTMV}}$	Timer Output Delay		25		20	ns

**Notes:**

All timing parameters are measured at 1.5 V with 50 pF loading on CLKOUTA, unless otherwise noted. All output test conditions are with  $C_L=50$  pF. For switching tests,  $V_{IL}=0.45$  V and  $V_{IH}=2.4$  V, except at X1 where  $V_{IH}=V_{CC}-0.5$  V.

a This timing must be met to guarantee proper operation.

b This timing must be met to guarantee recognition at the clock edge.

## SWITCHING CHARACTERISTICS over COMMERCIAL operating ranges Ready and Peripheral (33 MHz and 40 MHz)

Parameter			Preliminary				Unit
			33 MHz		40 MHz		
No.	Symbol	Description	Min	Max	Min	Max	
<b>Ready and Peripheral Timing Requirements</b>							
47	$t_{\text{SRVCL}}$	SRDY Transition Setup Time <sup>(a)</sup>	8		5		ns
48	$t_{\text{CLSRV}}$	SRDY Transition Hold Time <sup>(a)</sup>	3		2		ns
49	$t_{\text{ARVCH}}$	ARDY Resolution Transition Setup Time <sup>(b)</sup>	8		5		ns
50	$t_{\text{CLARX}}$	ARDY Active Hold Time <sup>(a)</sup>	4		3		ns
51	$t_{\text{ARVCHL}}$	ARDY Inactive Holding Time	6		5		ns
52	$t_{\text{ARVCL}}$	ARDY Setup Time <sup>(a)</sup>	10		5		ns
53	$t_{\text{INVCH}}$	Peripheral Setup Time <sup>(b)</sup>	8		5		ns
54	$t_{\text{INVCL}}$	DRQ Setup Time <sup>(b)</sup>	8		5		ns
<b>Peripheral Timing Responses</b>							
55	$t_{\text{CLTMV}}$	Timer Output Delay		15		12	ns

**Notes:**

All timing parameters are measured at 1.5 V with 50 pF loading on CLKOUTA, unless otherwise noted. All output test conditions are with  $C_L=50$  pF. For switching tests,  $V_{IL}=0.45$  V and  $V_{IH}=2.4$  V, except at X1 where  $V_{IH}=V_{CC}-0.5$  V.

a This timing must be met to guarantee proper operation.

b This timing must be met to guarantee recognition at the clock edge.

## SYNCHRONOUS, ASYNCHRONOUS, and PERIPHERAL WAVEFORMS

### Synchronous Ready Waveforms

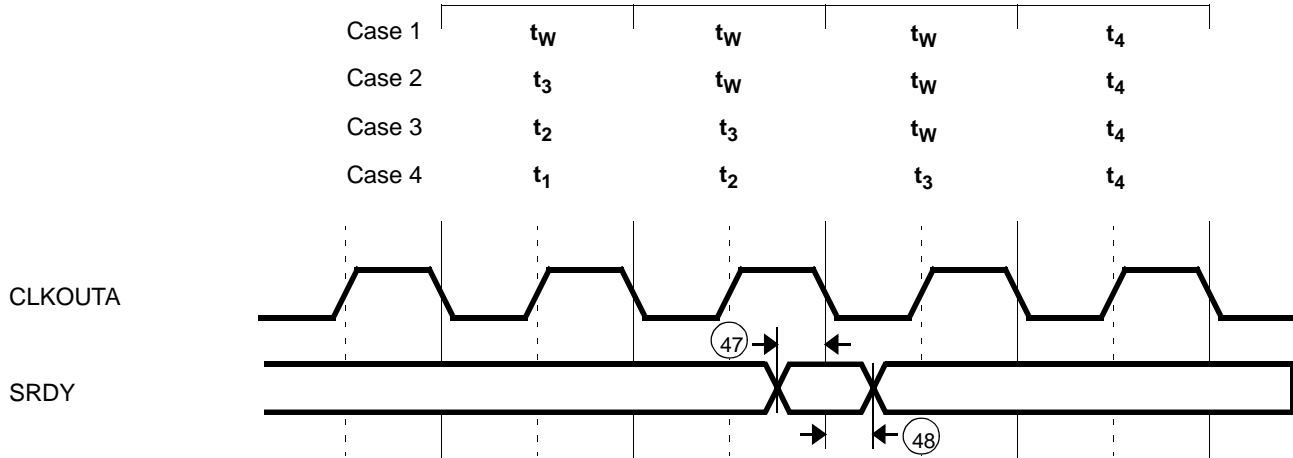

### Asynchronous Ready Waveforms

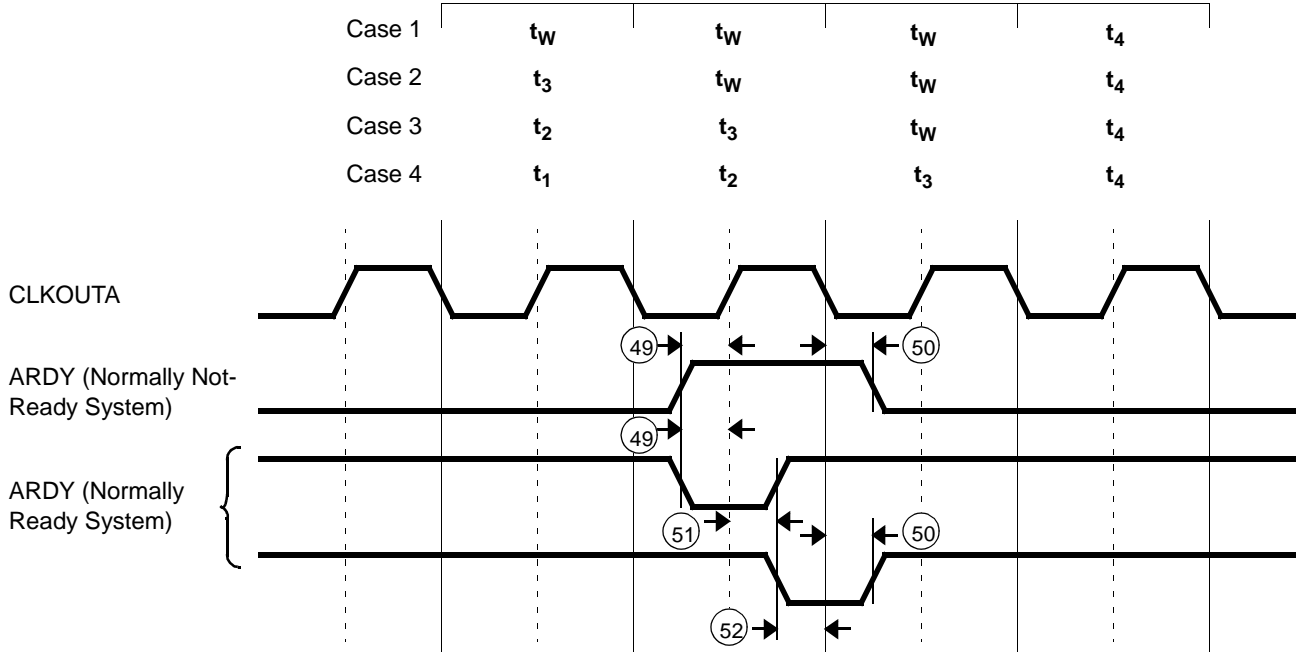

### Peripheral Waveforms

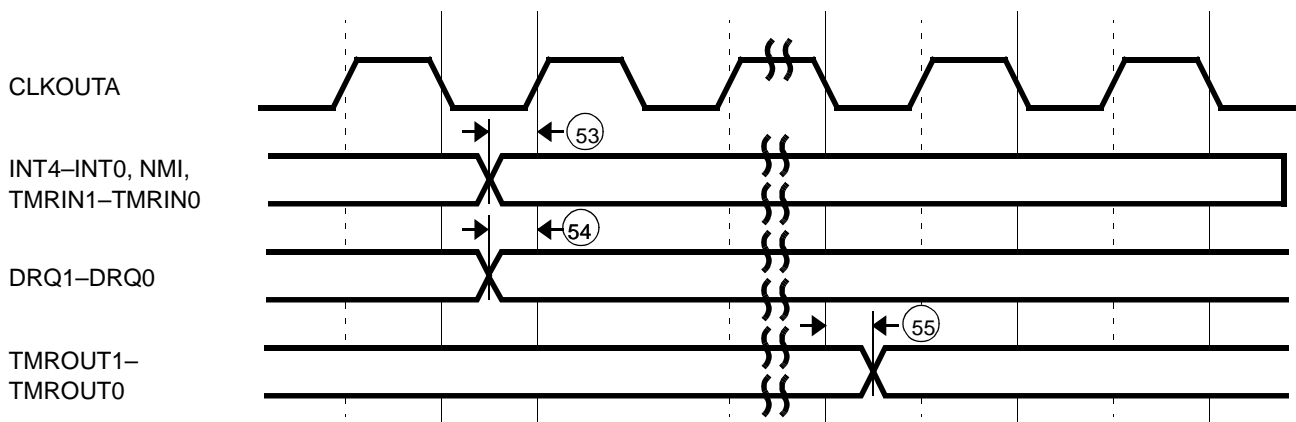

## SWITCHING CHARACTERISTICS over COMMERCIAL and INDUSTRIAL operating ranges Reset and Bus Hold (20 MHz and 25 MHz)

Parameter			Preliminary				Unit
			20 MHz		25 MHz		
No.	Symbol	Description	Min	Max	Min	Max	
<b>Reset and Bus Hold Timing Requirements</b>							
5	$t_{CLAV}$	AD Address Valid Delay and BHE	0	25	0	20	ns
15	$t_{CLAZ}$	AD Address Float Delay	0	25	0	20	ns
57	$t_{RESIN}$	RES Setup Time	10		10		ns
58	$t_{HVCL}$	HOLD Setup <sup>(a)</sup>	10		10		ns
<b>Reset and Bus Hold Timing Responses</b>							
62	$t_{CLHAV}$	HLDA Valid Delay	0	25	0	20	ns
63	$t_{CHCZ}$	Command Lines Float Delay		25		20	ns
64	$t_{CHCV}$	Command Lines Valid Delay (after Float)		25		20	ns

## SWITCHING CHARACTERISTICS over COMMERCIAL operating ranges Reset and Bus Hold (33 MHz and 40 MHz)

Parameter			Preliminary				Unit
			33 MHz		40 MHz		
No.	Symbol	Description	Min	Max	Min	Max	
<b>Reset and Bus Hold Timing Requirements</b>							
5	$t_{CLAV}$	AD Address Valid Delay and BHE	0	15	0	12	ns
15	$t_{CLAZ}$	AD Address Float Delay	0	15	0	12	ns
57	$t_{RESIN}$	RES Setup Time	8		5		ns
58	$t_{HVCL}$	HOLD Setup <sup>(a)</sup>	8		5		ns
<b>Reset and Bus Hold Timing Responses</b>							
62	$t_{CLHAV}$	HLDA Valid Delay	0	15	0	12	ns
63	$t_{CHCZ}$	Command Lines Float Delay		15		12	ns
64	$t_{CHCV}$	Command Lines Valid Delay (after Float)		15		12	ns

### Notes:

All timing parameters are measured at 1.5 V with 50 pF loading on CLKOUTA, unless otherwise noted. All output test conditions are with  $C_L=50$  pF. For switching tests,  $V_{IL}=0.45$  V and  $V_{IH}=2.4$  V, except at X1 where  $V_{IH}=V_{CC}-0.5$  V.

a This timing must be met to guarantee recognition at the next clock.



## RESET and BUS HOLD WAVEFORMS

### Reset Waveforms

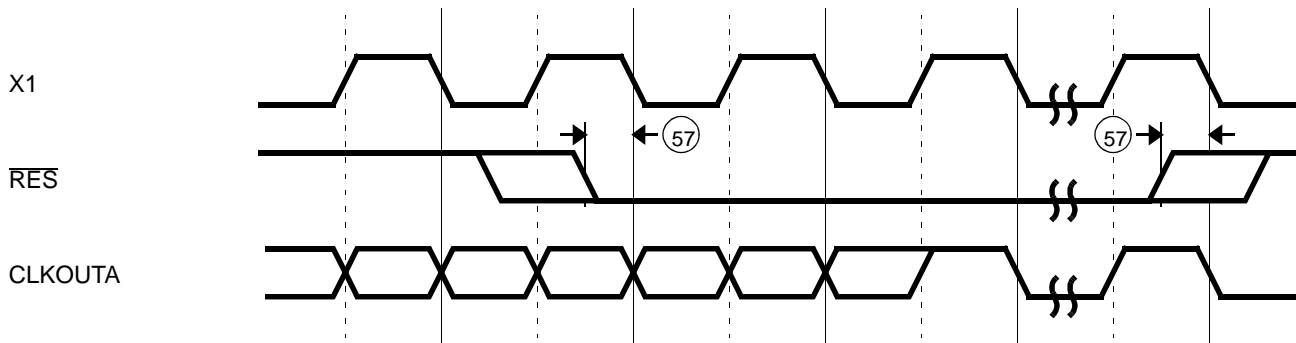

### Signals Related to Reset Waveforms

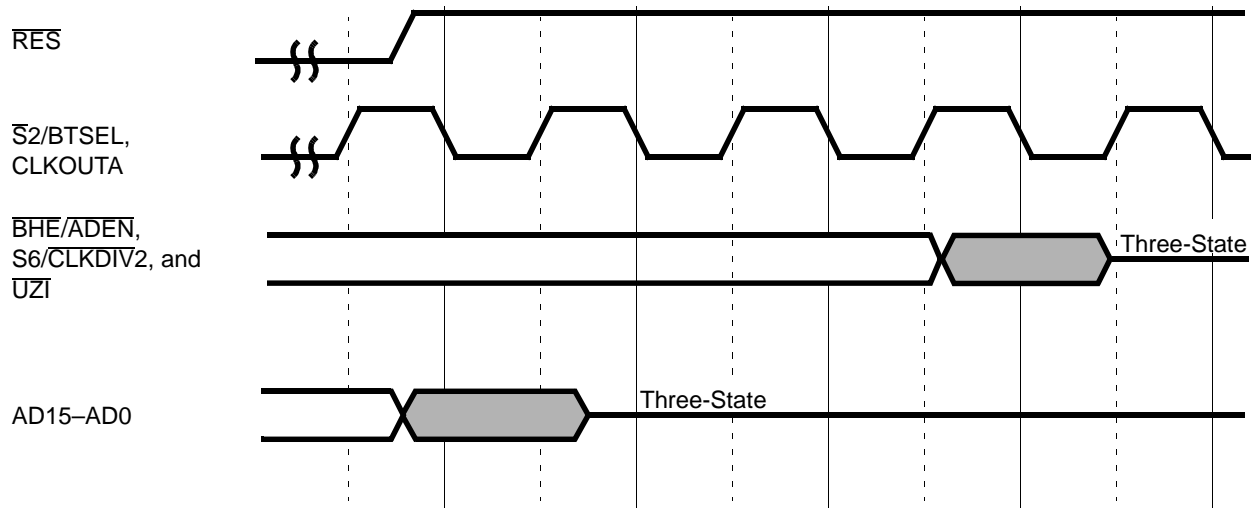

Bus Hold Waveforms—Entering

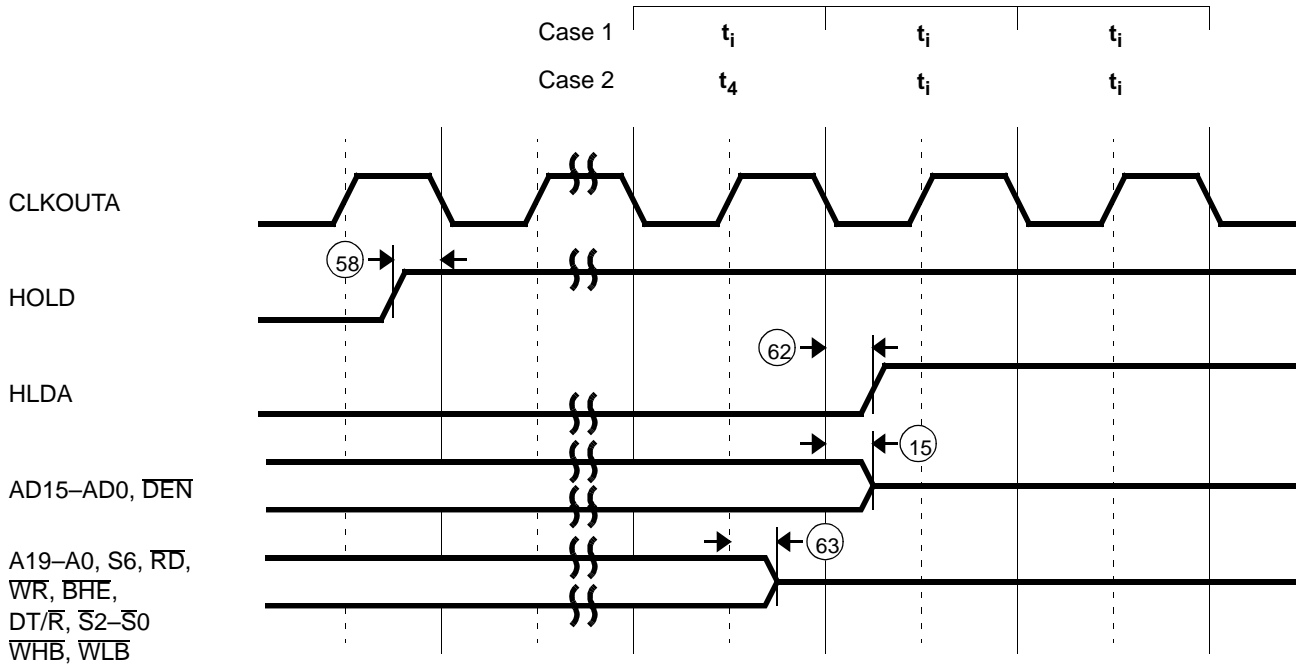

Bus Hold Waveforms—Leaving

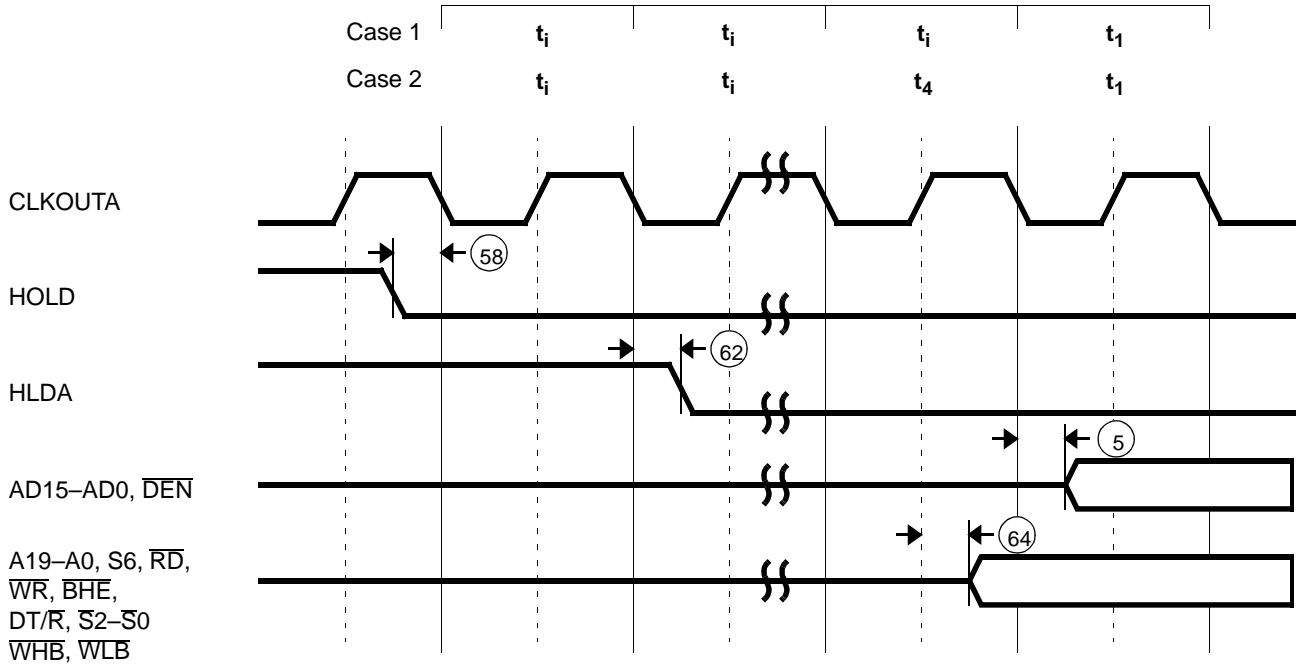

**TQFP PHYSICAL DIMENSIONS**  
**PQL 100, Trimmed and Formed**  
**Thin Quad Flat Pack**

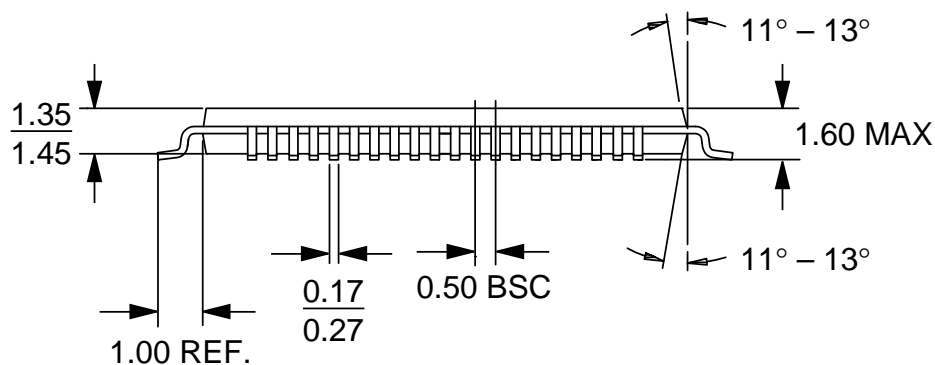
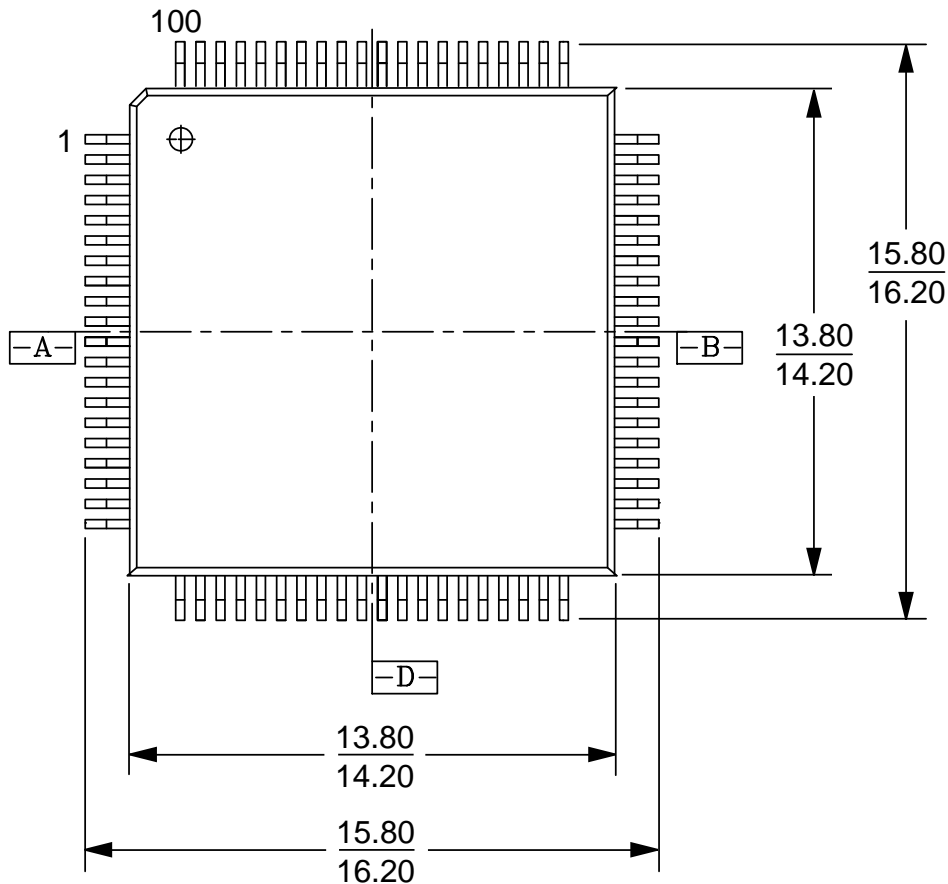

16-038-PQT-2\_AI  
 PQL100  
 9.3.96 Iv

**Notes:**

1. All measurements are in millimeters, unless otherwise noted.
2. Not to scale; for reference only.

**PQFP PHYSICAL DIMENSIONS**  
**PQR 100, Trimmed and Formed**  
**Plastic Quad Flat Pack**

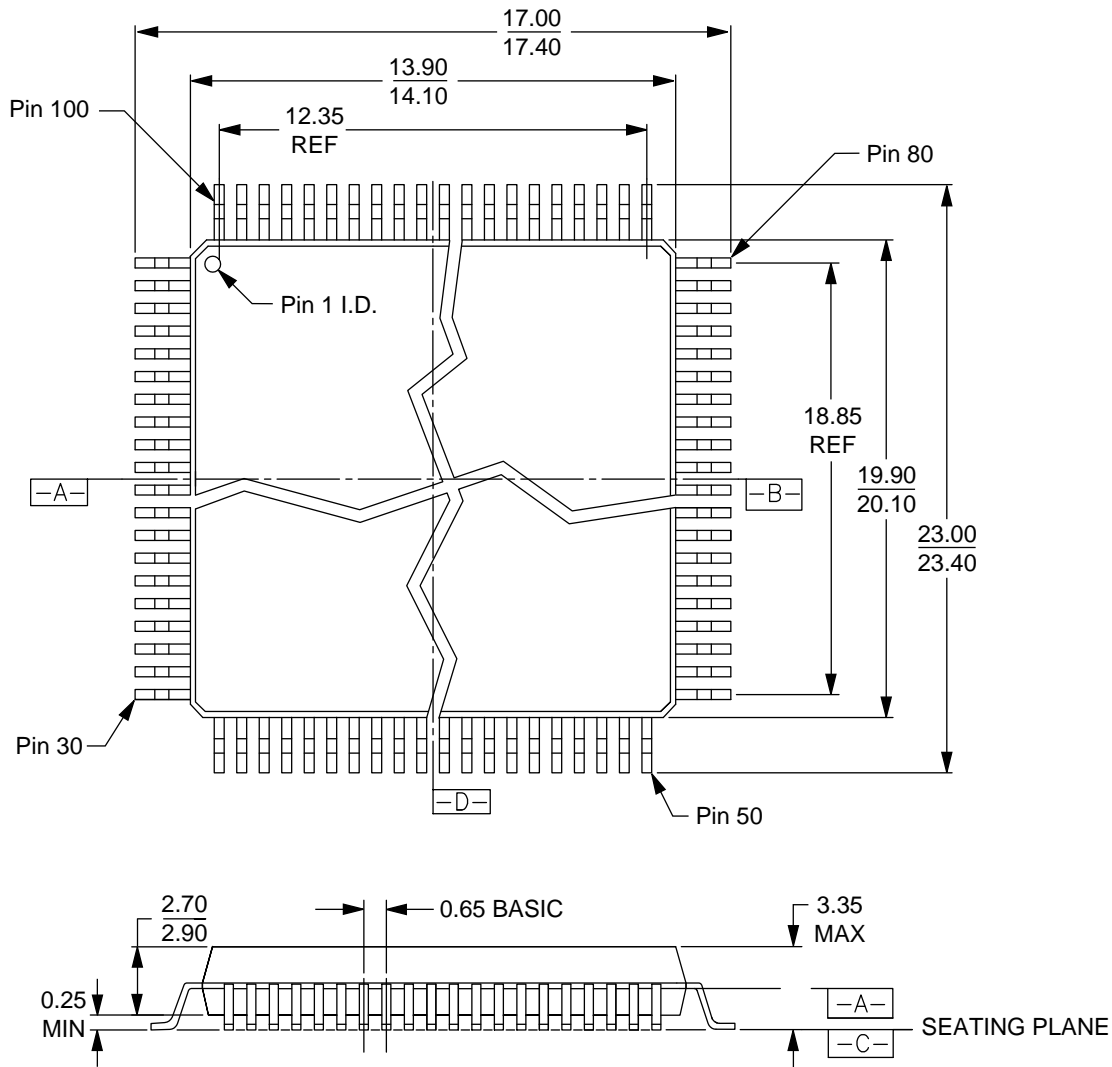

16-038-PQR-1\_AH  
 PQR100  
 DP92  
 6-20-96 lv

**Notes:**

1. All measurements are in millimeters, unless otherwise noted.
2. Not to scale; for reference only.

**Trademarks**

AMD, the AMD logo, and combinations thereof are trademarks of Advanced Micro Devices, Inc.

Am386 and Am486 are registered trademarks of Advanced Micro Devices, Inc.

Am186, Am188, E86, K86, Élan, and AMD Facts-On-Demand are trademarks of Advanced Micro Devices, Inc.

FusionE86 is a service mark of Advanced Micro Devices, Inc.

Product names used in this publication are for identification purposes only and may be trademarks of their respective companies.