

# SKiiP 11NAB065V1

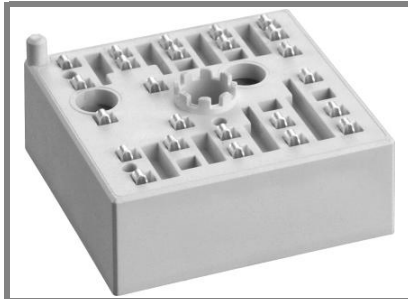

MiniSKiiP® 1

3-phase bridge rectifier +  
brake chopper + 3-phase  
bridge inverter  
SKiiP 11NAB065V1

## Features

- Ultrafast NPT IGBTs
- Robust and soft freewheeling diodes in CAL technology
- Highly reliable spring contacts for electrical connections
- UL recognised file no. E63532

## Typical Applications

- Inverter up to 3,5 kVA
- Typical motor power 1,5 kW

## Remarks

- $V_{CEsat}$ ,  $V_F$  = chip level value

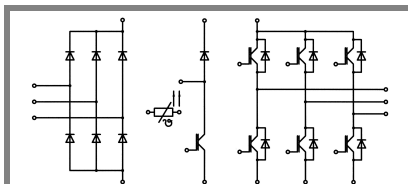

NAB

Absolute Maximum Ratings		$T_s = 25^\circ\text{C}$ , unless otherwise specified	
Symbol	Conditions	Values	Units
<b>IGBT - Inverter, Chopper</b>			
$V_{CES}$		600	V
$I_C$	$T_s = 25 (70)^\circ\text{C}$	12 (10)	A
$I_{CRM}$	$t_p \leq 1 \text{ ms}$	12	A
$V_{GES}$		$\pm 20$	V
$T_j$		- 40 ... + 150	$^\circ\text{C}$
<b>Diode - Inverter, Chopper</b>			
$I_F$	$T_s = 25 (70)^\circ\text{C}$	12 (12)	A
$I_{FRM}$	$t_p \leq 1 \text{ ms}$	12	A
$T_j$		- 40 ... + 150	$^\circ\text{C}$
<b>Diode - Rectifier</b>			
$V_{RRM}$		800	V
$I_F$	$T_s = 70^\circ\text{C}$	35	A
$I_{FSM}$	$t_p = 10 \text{ ms}$ , $\sin 180^\circ$ , $T_j = 25^\circ\text{C}$	220	A
$i^2t$	$t_p = 10 \text{ ms}$ , $\sin 180^\circ$ , $T_j = 25^\circ\text{C}$	240	$\text{A}^2\text{s}$
$T_j$		- 40 ... + 150	$^\circ\text{C}$
$I_{RMS}$	per power terminal (20 A / spring)	20	A
$T_{stg}$	$T_{op} \leq T_{stg}$	- 40 ... + 125	$^\circ\text{C}$
$V_{isol}$	AC, 1 min.	2500	V

Characteristics		$T_s = 25^\circ\text{C}$ , unless otherwise specified			
Symbol	Conditions	min.	typ.	max.	Units
<b>IGBT - Inverter, Chopper</b>					
$V_{CEsat}$	$I_{Cnom} = 6 \text{ A}$ , $T_j = 25 (125)^\circ\text{C}$		2 (2,2)	2,5 (2,7)	V
$V_{GE(th)}$	$V_{GE} = V_{CE}$ , $I_C = 0,5 \text{ mA}$	3	4	5	V
$V_{CE(TO)}$	$T_j = 25 (125)^\circ\text{C}$		1,2 (1,1)	1,3 (1,2)	V
$r_T$	$T_j = 25 (125)^\circ\text{C}$		133 (183)	200 (250)	$\text{m}\Omega$
$C_{ies}$	$V_{CE} = 25 \text{ V}$ , $V_{GE} = 0 \text{ V}$ , $f = 1 \text{ MHz}$		0,32		nF
$C_{oes}$	$V_{CE} = 25 \text{ V}$ , $V_{GE} = 0 \text{ V}$ , $f = 1 \text{ MHz}$		0,08		nF
$C_{res}$	$V_{CE} = 25 \text{ V}$ , $V_{GE} = 0 \text{ V}$ , $f = 1 \text{ MHz}$		0,03		nF
$R_{th(j-s)}$	per IGBT		1,9		K/W
$t_{d(on)}$	under following conditions		25		ns
$t_r$	$V_{CC} = 300 \text{ V}$ , $V_{GE} = \pm 15 \text{ V}$		30		ns
$t_{d(off)}$	$I_{Cnom} = 6 \text{ A}$ , $T_j = 125^\circ\text{C}$		195		ns
$t_f$	$R_{Gon} = R_{Goff} = 120 \Omega$		20		ns
$E_{on}$	inductive load		0,3		mJ
$E_{off}$			0,2		mJ
<b>Diode - Inverter, Chopper</b>					
$V_F = V_{EC}$	$I_{Fnom} = 6 \text{ A}$ , $T_j = 25 (125)^\circ\text{C}$		1,3 (1,2)	1,5 (1,4)	V
$V_{(TO)}$	$T_j = 25 (125)^\circ\text{C}$		1 (0,9)	1,1 (1)	V
$r_T$	$T_j = 25 (125)^\circ\text{C}$		45 (50)	60 (70)	$\text{m}\Omega$
$R_{th(j-s)}$	per diode		2,5		K/W
$I_{RRM}$	under following conditions		8,3		A
$Q_{rr}$	$I_{Fnom} = 6 \text{ A}$ , $V_R = 300 \text{ V}$		0,6		$\mu\text{C}$
$E_{rr}$	$V_{GE} = 0 \text{ V}$ , $T_j = 125^\circ\text{C}$		0,2		mJ
	$di_F/dt = 430 \text{ A}/\mu\text{s}$				
<b>Diode - Rectifier</b>					
$V_F$	$I_{Fnom} = 15 \text{ A}$ , $T_j = 25^\circ\text{C}$		1,1		V
$V_{(TO)}$	$T_j = 150^\circ\text{C}$		0,8		V
$r_T$	$T_j = 150^\circ\text{C}$		20		$\text{m}\Omega$
$R_{th(j-s)}$	per diode		1,5		K/W
<b>Temperature Sensor</b>					
$R_{ts}$	3 %, $T_r = 25 (100)^\circ\text{C}$		1000(1670)		$\Omega$
<b>Mechanical Data</b>					
w			35		g
$M_s$	Mounting torque	2		2,5	Nm

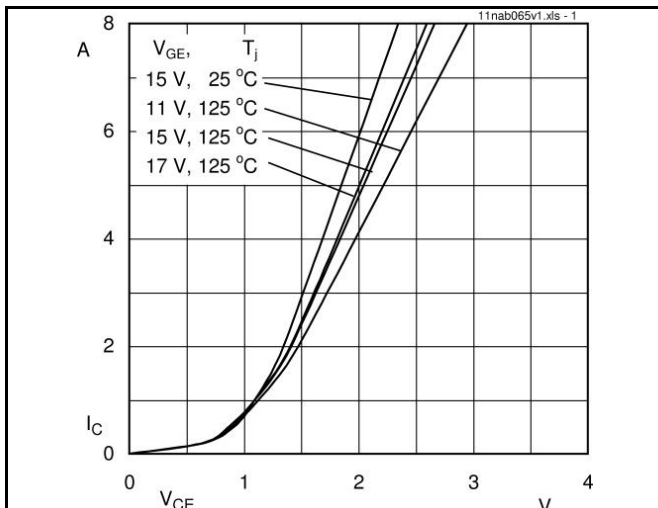

Fig. 1 Typ. output characteristic

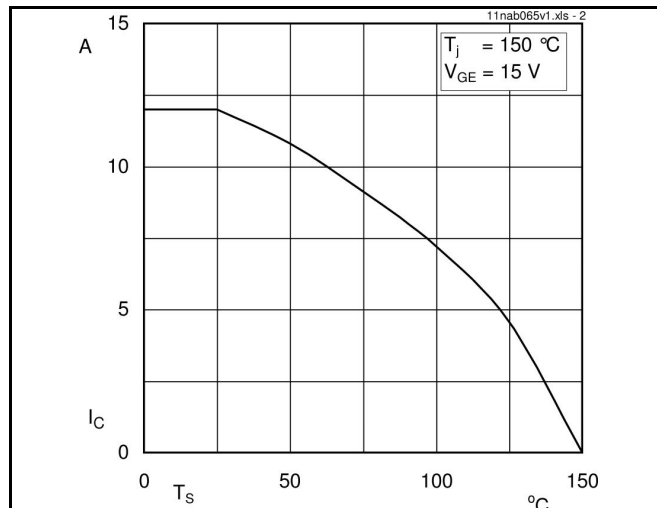

Fig. 2 Typ. rated current vs. temperature

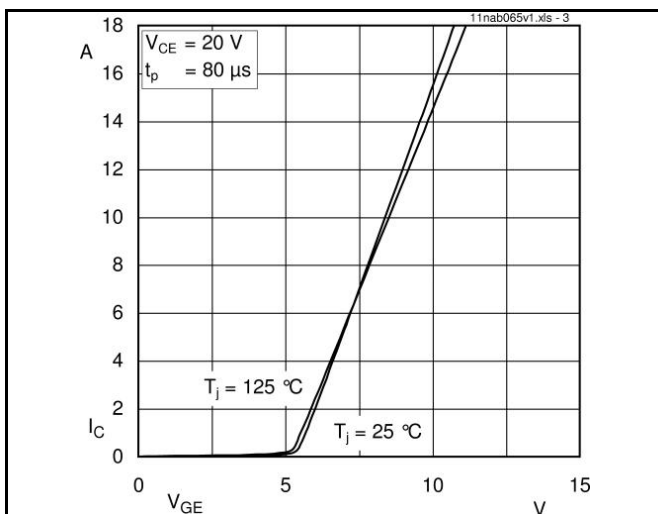

Fig. 3 Typ. transfer characteristic

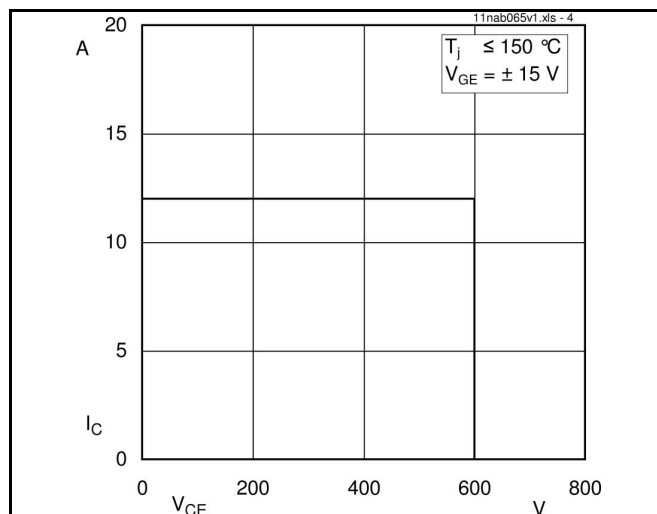

Fig. 4 Reverse bias safe operating area

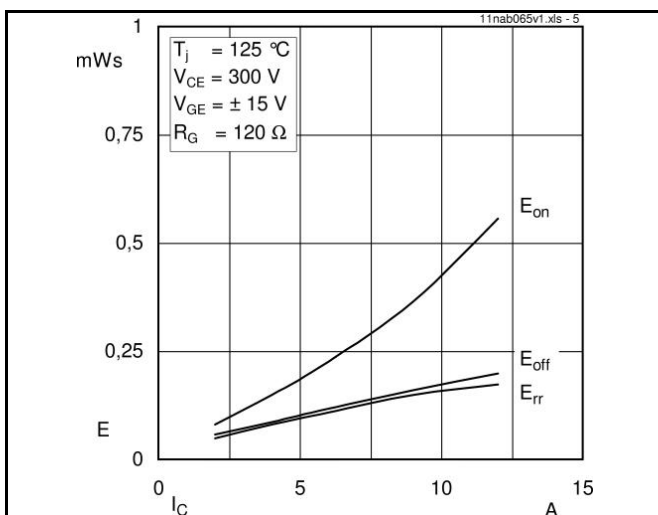

Fig. 5 Typ. Turn-on /-off energy =  $f(I_C)$

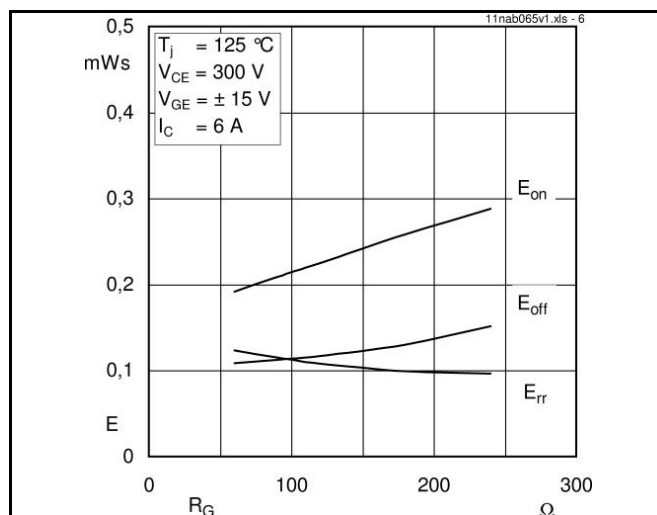

Fig. 6 Typ. Turn-on /-off energy =  $f(R_G)$

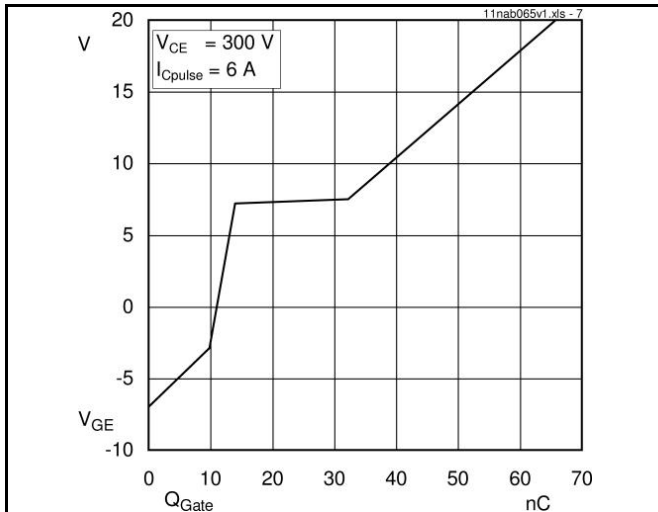

Fig. 7 Typ. gate charge characteristic

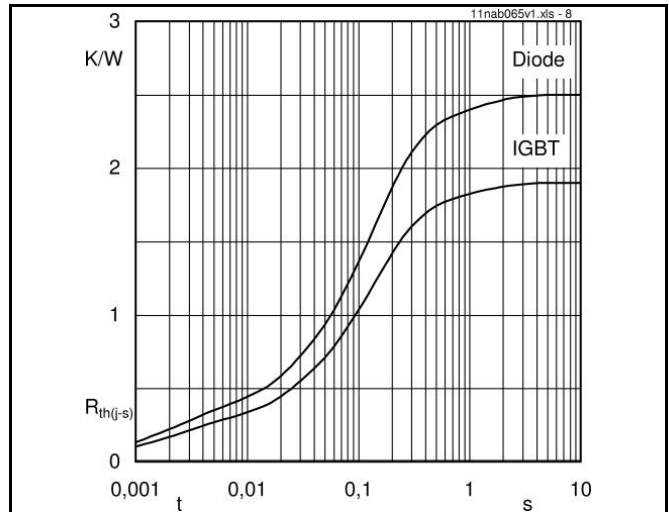

Fig. 8 Typ. thermal impedance

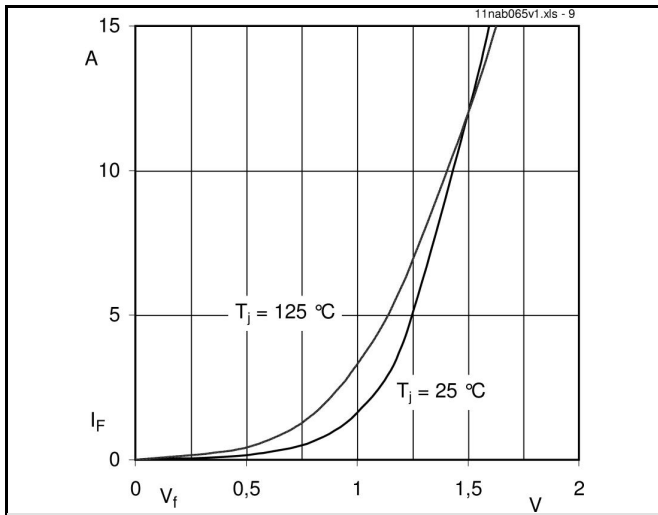

Fig. 9 Typ. freewheeling diode forward characteristic

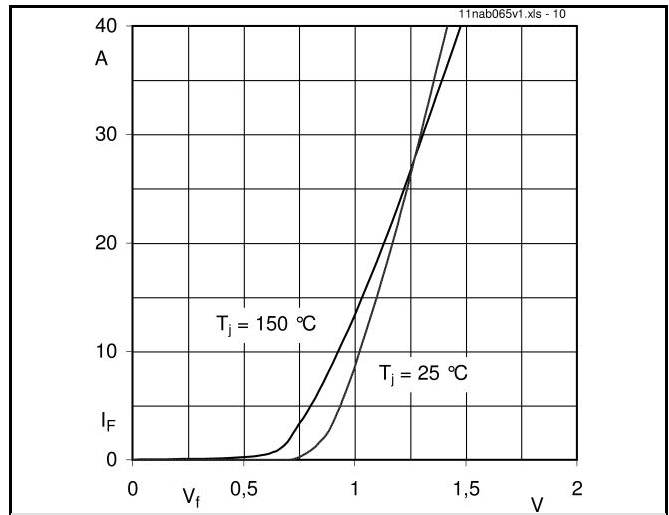
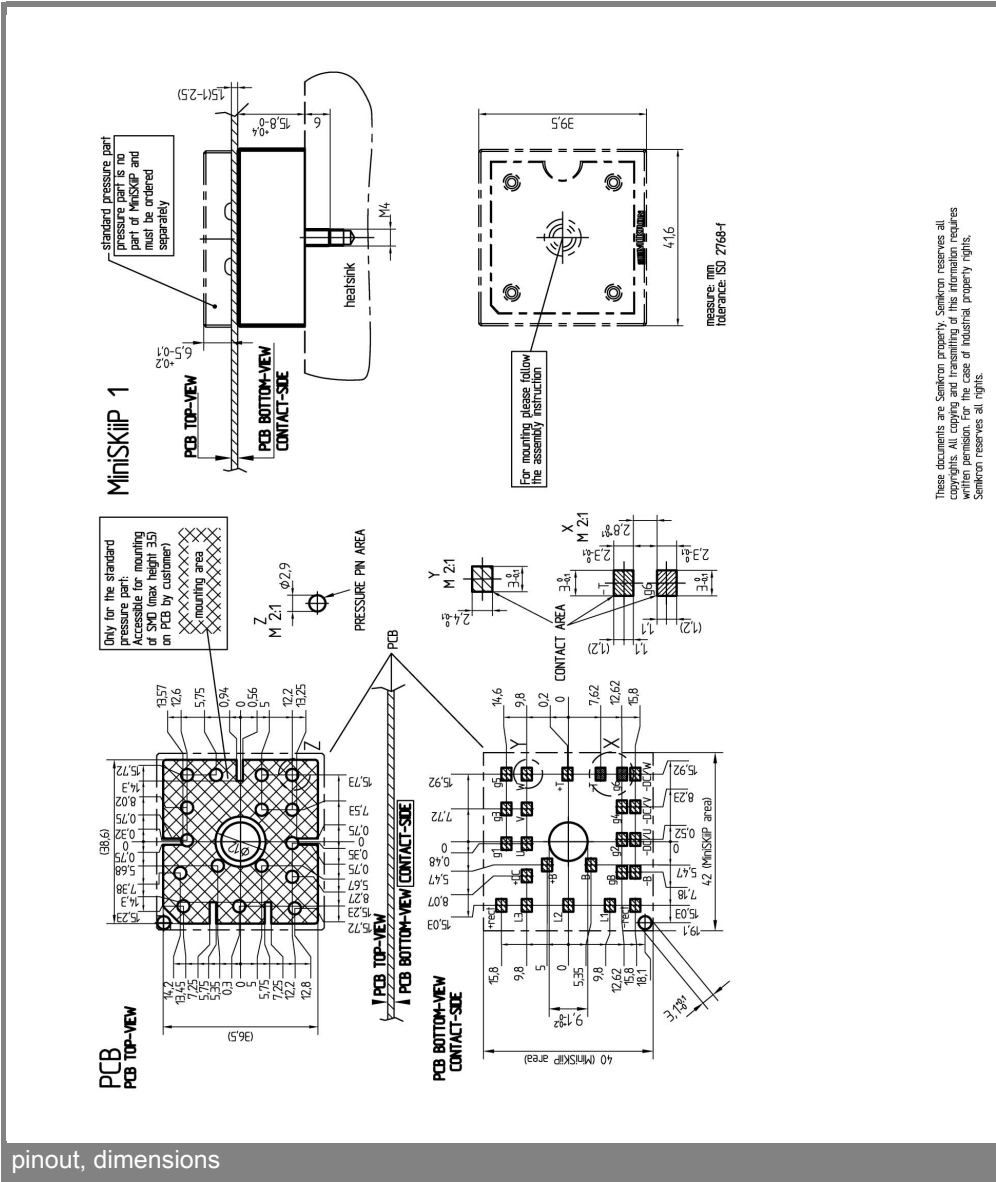
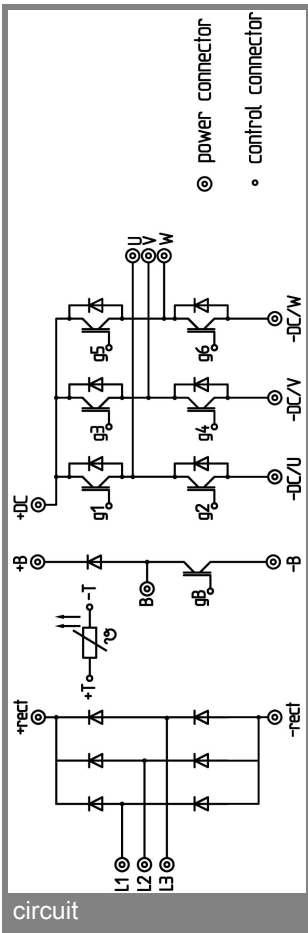

Fig. 10 Typ. input bridge forward characteristic



These documents are Semikron property. Semikron reserves all copyrights. All copying and transmitting of this information requires the prior written consent of Semikron. Semikron reserves all rights.